





# Incremental Hollow Shaft Encoder RI 58-D, RI 58TD

Page 2/2

## Mechanical installation

### General information

#### Safety instructions

- All installation work must be carried out according to applicable safety instructions!
- During installation work all appliances worked on must be disconnected from electric current!  
Ensure that these appliances cannot be powered up during the installation work!
- In order to compensate for axial or radial angular offset of the actuating shaft, flange and case of the shaft encoder must remain movable!

The shaft encoder case must not rotate:

Fix the flange by means of

- a stator coupling (e.g. spring steel plate) (Accessories: Ord. code 1 531 162)
- or a cylindrical pin. A torque spring (at the encoder flange) in conjunction with a cylindrical pin (at the actuating device) provides for the transmission of torque between encoder and actuating device.

### Prerequisites for installation

#### at the actuating shaft (only in version E):

The actuating shaft must be provided with a threaded bore M4x10:  
This bore accepts the fastening screw of the shaft encoder.

#### at the actuator case (for mounting with cylindrical pin):

A cylindrical pin must be installed in the actuator housing (pin diameter versions E and H: 4x16; versions D and F: 4x20; always DIN 6325).  
This pin is required as a torque support (refer also to safety instructions)  
Please observe the following dimensioned drawings.

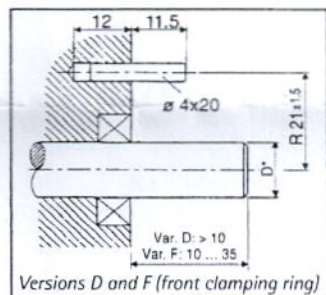

Versions D and F (front clamping ring)

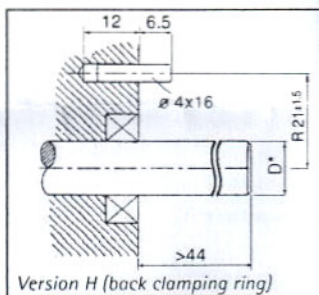

Version H (back clamping ring)

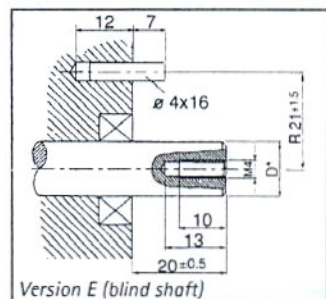

Version E (blind shaft)

- \* D = 10/12/14 mm (versions D + H)
- \* D = 10/12/14/15 mm (versions E + F)

### Assembly drawings

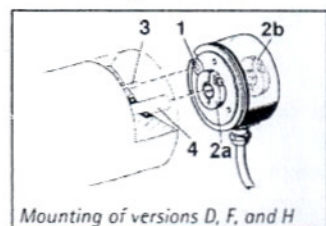

Mounting of versions D, F, and H

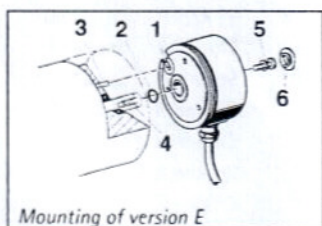

Mounting of version E

#### Legend for versions D, F, and H

- 1 Torque spring
- 2a Clamping ring with hexagon-socket screw, front (D+F)
- 2b Clamping ring with hexagon-socket screw, back (H)
- 3 Cylindrical pin
- 4 Actuating shaft

#### Legend for version E

- 1 Torque spring
- 2 O-ring
- 3 Cylindrical pin
- 4 Actuating shaft with threaded bore
- 5 M4-screw with spring washer
- 6 Cap

### Checking the clamping device (D, F, and H versions)

The clamping device of versions D, F, and H contains a clamping ring with a hexagon-socket screw.

Versions D and F: Clamping ring and torque spring are located on the front side of the shaft encoder. This side will later on point to the actuator.  
With version H, the clamping ring is located in the back, the torque spring is in front.

The front side will later on point to the actuator.

#### Check first whether the clamping ring is open:

- Hold the encoder in such a position that you can see the clamping ring from the side: The hexagon-socket screw is inserted into the side of the clamping ring.
- Check whether the clamping device of the hollow shaft is released by inserting the actuating shaft into the hollow shaft.  
The shaft must slide into the hollow shaft smoothly!  
Do not use force and do not try to drive the shaft into the hollow with hammer blows!  
This would damage the shaft encoder!
- If the shaft cannot be inserted: check the shaft diameter and/or release the clamping device.

### Releasing the clamping device (D, F, and H versions)

- Open the clamping ring:  
Use a hex key (size 2); turn the screw to the left (counter-clockwise).

### Mounting the encoder at the actuating shaft

#### For clamping shaft/clamping device versions (D, F, and H):

- For mounting with stator coupling:  
Fasten the spring steel plate to the encoders flange.
- Slide the encoder onto the actuating shaft.
- For mounting with cylindrical pin:  
Align the encoder in such a position that the torque spring and the cylindrical pin oppose each other. Engage the cylindrical pin in the torque spring.
- For mounting with stator coupling:  
Align the encoder in such a position that the bores of the spring steel plate and of the actuator housing oppose each other.
- Close the clamping ring:  
Use a hex key (size 2); turn the screw to the right (clockwise).  
Tightening torque of the clamping-ring screw: 90 ... 100 Ncm!
- For mounting with stator coupling:  
Screw together the spring steel plate and the actuator housing.

#### For blind shaft version (E):

- For mounting with stator coupling:  
Fasten the spring steel plate to the encoders flange.
- Put the O-ring\* into the hollow shaft and slide the encoder onto the actuating shaft.
- For mounting with cylindrical pin:  
Align the encoder in such a position that the torque spring and the cylindrical pin oppose each other. Engage the cylindrical pin in the torque spring.
- For mounting with stator coupling:  
Align the encoder in such a position that the bores of the spring steel plate and of the actuator housing oppose each other.
- Put the spring washer\* on the Phillips screw (M4x12)\*.  
Hold the spring washer to the screw head.
- Push the screw with the spring washer through the case opening and the shaft bore of the encoder into the threaded bore at the end of the actuating shaft.
- Secure the encoder on the actuating shaft:  
Use a Phillips screwdriver;  
Turn the screw to the right (clockwise) and tighten it moderately.
- Push the cap\* into the case opening.
- For mounting with stator coupling:  
Screw together the spring steel plate and the actuator housing.

\* supplied with the encoder

The encoder is now ready for connection.

Ensure that no external forces act on the shaft encoder during installation and operation!



AWM I/II A/B 800C 3000 FT1 - CE  
AWM STYLE 2464 80

AWM I/II A/B 800C 3000



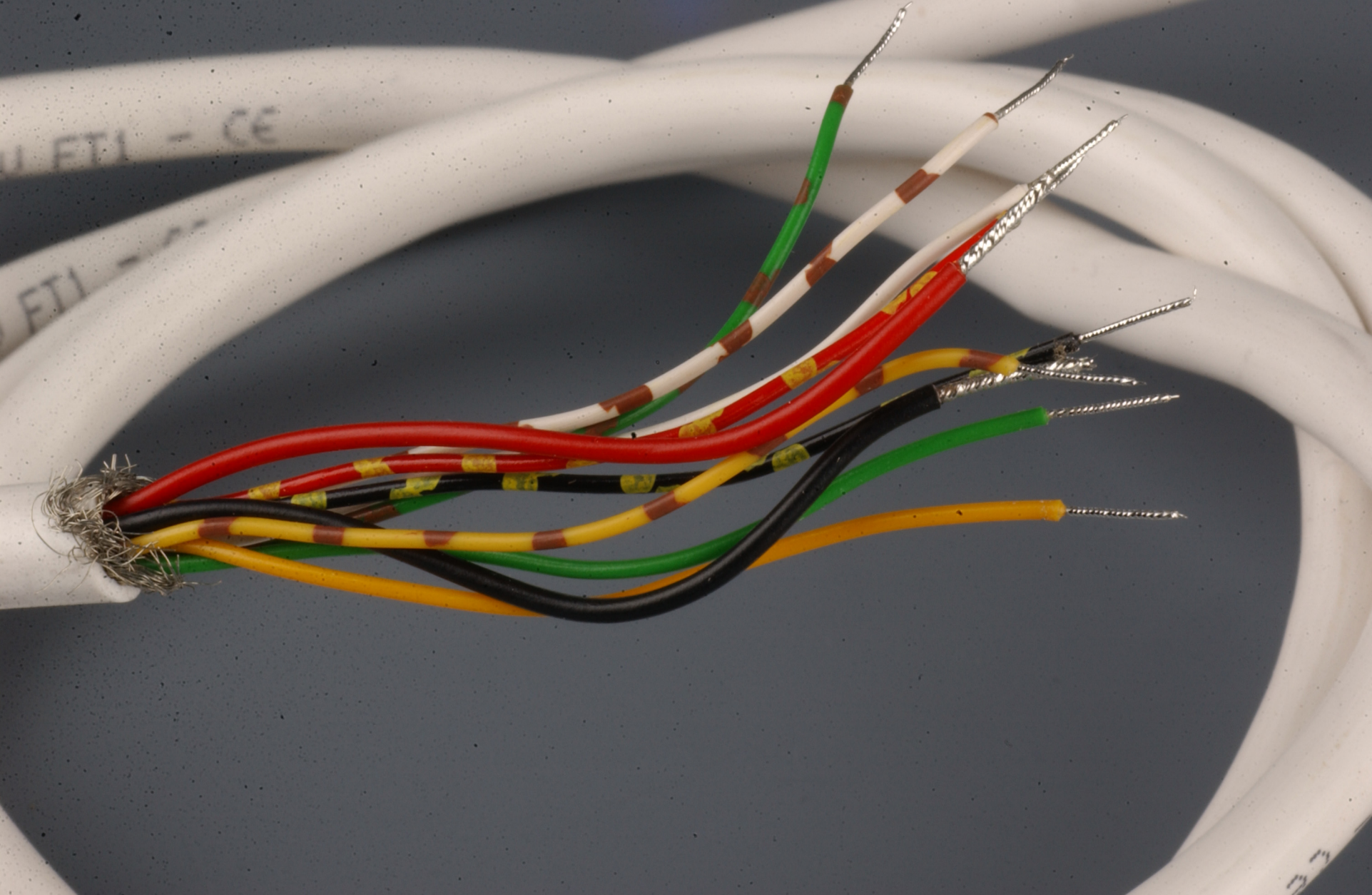

## Industrial types

## Hollow shaft



- Flexible hollow shaft design up to diameter 14 mm
- Short overall length
- Easy installation by means of clamping shaft or blind shaft
- Application e.g.:
  - actuators
  - length measuring machines
  - motors
- Operating temperature up to 100 °C (RI 58 TD)
- Various shaft versions:
  - Mounting code E = Blind shaft (not through)
  - Mounting code F = Clamping shaft (not through)
  - Mounting code D = Clamping shaft (solid shaft)

### NUMBER OF PULSES

RI 58-D

1 / 2 / 3 / 4 / 5 / 10 / 20 / 25 / 30 / 35 / 40 / 45 / 50 / 60 / 64 / 70 / 72 / 80 / **100** / 125 / 128 / 144 / 150 / 180 / 200 / **250** / 256 / 300 / 314 / 350 / 360 / 375 / 400 / 460 / 480 / **500** / 512 / 600 / 625 / 720 / 900 / **1000** / **1024** / **1250** / 1500 / 1600 / 1800 / 2000 / 2048 / **2500** / 3000 / 3480 / **3600** / 4000 / **4096** / **5000**

RI 58 TD

(high temperature) as above, but only for the range from 4 ... 2500 pulses  
Other number of pulses on request  
Preferably available versions are printed in bold type.

### TECHNICAL DATA mechanical

Mounting	Synchro flange with clamping shaft or blind shaft
Shaft diameter	Hollow shaft 10 mm, hollow shaft 12 mm, hollow shaft 14 mm (not through)
Required dimensions of mounting shaft	Ø 10 mm, tolerance g8 (-0.005...-0.027 mm) Ø 12/14 mm, tolerance g8 (-0.006...-0.033 mm)
Absolute max. speed	E, F: max. 6000 min <sup>-1</sup> ; D: max 4000 min <sup>-1</sup>
Torque	≤ 1 Ncm with non-through shaft (E, F) ≤ 2 Ncm with through shaft (D)
Moment of inertia	F: approx. 35 gcm <sup>2</sup> (clamping non through shaft) E: approx. 20 gcm <sup>2</sup> (end shaft) D: approx. 60 gcm <sup>2</sup> (clamping through shaft)
Protection class (EN 60529)	E, F: housing IP65, bearings IP64 D: housing IP64, bearings IP64
Operating temperature	-10 ... +70 °C, Option: -25 ...+100°C
Storage temperature	-25 ... +85 °C
Vibration resistance (IEC 68-2-6)	10 g = 100 m/s <sup>2</sup> (10 ... 2000 Hz)
Shock resistance (IEC 68-2-27)	100 g = 1000 m/s <sup>2</sup> (6 ms)
Connection	1.5 m cable <sup>1</sup> or connector, radial
Housing	Aluminium
Weight approx.	E, F: 170 g; D: 190 g

<sup>1</sup> Other cable length on request

# Incremental Shaft Encoders Type RI 58-D

## Industrial types

### Hollow shaft

#### TECHNICAL DATA electrical

General design	as per DIN VDE 0160, protection class III, contamination level 2, overvoltage class II	
Supply voltage (SELV)	with RS 422 + Sense (T):	DC 5 V ± 10 %
	with RS 422 + Alarm (R):	DC 5 V ± 10 % oder DC 10 - 30 V <sup>1</sup>
	with push-pull (K, I):	DC 10 - 30 V <sup>1</sup>
Max. current w/o load	40 mA (5 VDC), 60 mA (10 VDC), 30 mA (24 VDC)	
Standard output versions <sup>2</sup>	RS 422 (R):	A, B, N, $\bar{A}$ , $\bar{B}$ , $\bar{N}$ , Alarm
	RS 422 (T):	A, B, N, $\bar{A}$ , $\bar{B}$ , $\bar{N}$ , Sense
	push-pull (K):	A, B, N, Alarm
	push-pull complementary (I):	A, B, N, $\bar{A}$ , $\bar{B}$ , $\bar{N}$ , Alarm

<sup>1</sup> Pole protection with supply voltage DC 10 - 30 V

<sup>2</sup> Output description and technical data see chapter "Technical basics"

#### DIMENSIONAL DRAWINGS

Mounting = F: clamping shaft, not through

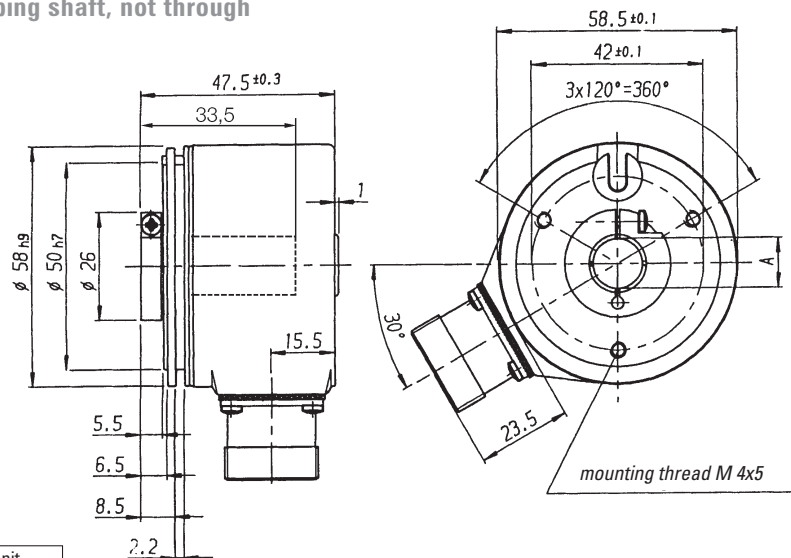

Dim.:	Hollow shaft Ø	Unit
A	10 <sup>H7</sup> 12 <sup>H7</sup> 14 <sup>H7</sup>	mm
A*	10 <sup>g8</sup> 12 <sup>g8</sup> 14 <sup>g8</sup>	mm

A\* = Diameter of connection shaft

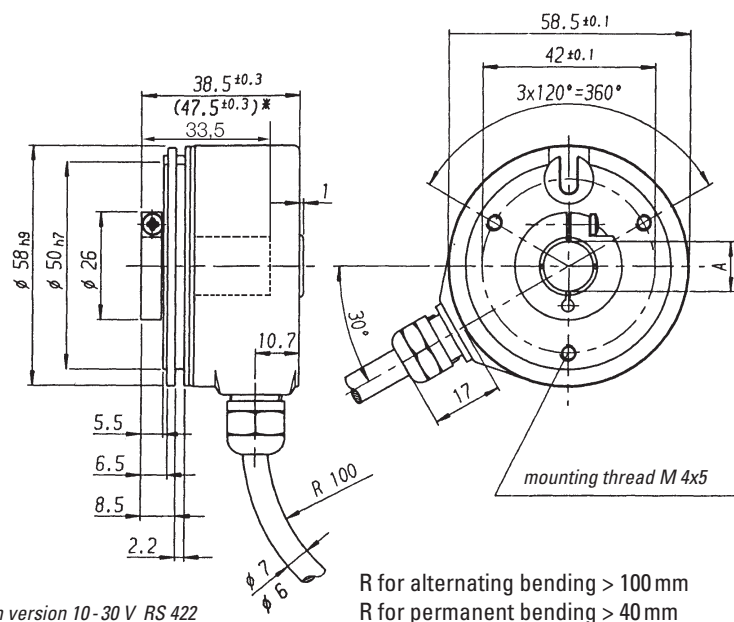

Dimensions in mm

\* with version 10 - 30 V RS 422

R for alternating bending > 100 mm  
R for permanent bending > 40 mm





# Incremental Shaft Encoders Industrial types

# Type RI 58-D Hollow shaft

## DIMENSIONAL DRAWINGS

Mounting = E, blind shaft (not through)

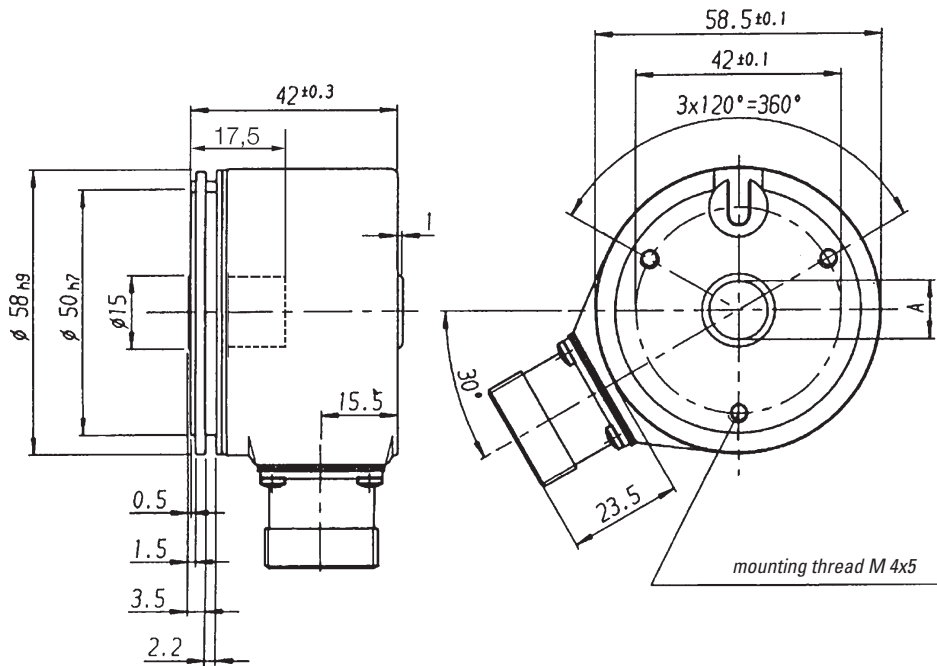

Dim.	Hollow shaft Ø	Unit
A	10 <sup>H7</sup> 12 <sup>H7</sup> 14 <sup>H7</sup>	mm
A*	10 <sup>g8</sup> 12 <sup>g8</sup> 14 <sup>g8</sup>	mm

A\* = Diameter of connection shaft

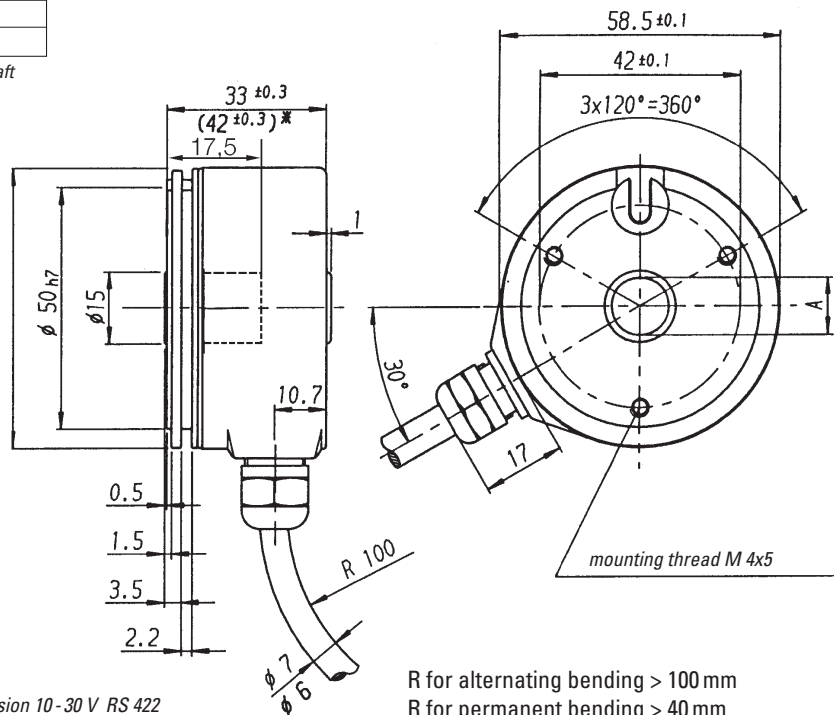

\* with Version 10-30 V RS 422

R for alternating bending > 100 mm  
R for permanent bending > 40 mm

Dimensions in mm

## Industrial types

## Hollow shaft

### MOUNTING NECESSITIES

In order to be able to compensate an axial and radial misalignment of the shaft, the encoder flange must not be fixed rigidly. Fix the flanges by means of a stator coupling (e.g. hubshaft with tether) as torque support (see "Accessories") or by means of a cylindrical pin:

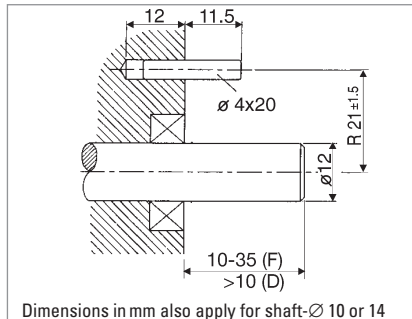

Dimensions in mm also apply for shaft- $\varnothing$  10 or 14

Mounting = D, F (Clamping shaft)

Preparation of the machine flange <sup>1</sup>

**(all mounting versions):**

In the machine flange a straight pin must be installed (diameter 4x16 resp. 4x20, DIN 6325).

This pin is required as a torque support.

<sup>1</sup> Or as an option: stator coupling as torque support

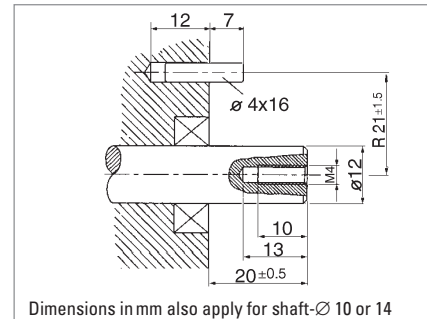

Dimensions in mm also apply for shaft- $\varnothing$  10 or 14

Mounting = E (Blind shaft)

Preparation of the drive shaft

**(only in mounting = E):**

The drive shaft must be provided with a threaded bore M 4 x 10:

This bore accepts the fastening screw of the shaft encoder.

### PIN ASSIGNMENT

#### Cable PVC

Cable	Output circuit			
	RS 422 + Sense (T)	RS 422 + Alarm (R)	push-pull (K)	push-pull complementary (I)
white	Channel A	Channel A	Channel A	Channel A
white/brown	Channel $\bar{A}$	Channel $\bar{A}$		Channel $\bar{A}$
green	Channel B	Channel B	Channel B	Channel B
green/brown	Channel $\bar{B}$	Channel $\bar{B}$		Channel $\bar{B}$
yellow	Channel N	Channel N	Channel N	Channel N
yellow/brown	Channel $\bar{N}$	Channel $\bar{N}$		Channel $\bar{N}$
yellow/black	Sense GND	Alarm	Alarm	Alarm
yellow/red	Sense V <sub>CC</sub>	Sense V <sub>CC</sub>		Sense V <sub>CC</sub>
red	DC 5 V	DC 5/10 - 30 V	DC 10 - 30 V	DC 10 - 30 V
black	GND	GND	GND	GND
Cable screen <sup>1</sup>	Cable screen <sup>1</sup>	Cable screen <sup>1</sup>	Cable screen <sup>1</sup>	Cable screen <sup>1</sup>

<sup>1</sup> connected with encoder housing

### PIN ASSIGNMENT

#### Cable TPE

Cable	Output circuit			
	RS 422 + Sense (T)	RS 422 + Alarm (R)	push-pull (K)	push-pull complementary (I)
brown	Channel A	Channel A	Channel A	Channel A
green	Channel $\bar{A}$	Channel $\bar{A}$		Channel $\bar{A}$
grey	Channel B	Channel B	Channel B	Channel B
pink	Channel $\bar{B}$	Channel $\bar{B}$		Channel $\bar{B}$
red	Channel N	Channel N	Channel N	Channel N
black	Channel $\bar{N}$	Channel $\bar{N}$		Channel $\bar{N}$
violet (white) <sup>2</sup>	Sense GND	Alarm	Alarm	Alarm
blue	Sense V <sub>CC</sub>	Sense V <sub>CC</sub>		Sense V <sub>CC</sub>
brown/green	DC 5 V	DC 5/10 - 30 V	DC 10 - 30 V	DC 10 - 30 V
white/green	GND	GND	GND	GND
Cable screen <sup>1</sup>	Cable screen <sup>1</sup>	Cable screen <sup>1</sup>	Cable screen <sup>1</sup>	Cable screen <sup>1</sup>

# Incremental Shaft Encoders Type RI 58-D

## Industrial types Hollow shaft

### PIN ASSIGNMENT Connector (CONIN)

Pin	RS 422 + Sense (T)	RS 422 + Alarm (R)	push-pull (K)	push-pull complementary (I)
1	Channel $\bar{B}$	Channel $\bar{B}$	N.C.	Channel $\bar{B}$
2	Sense $V_{CC}$	Sense $V_{CC}$	N.C.	Sense $V_{CC}$
3	Channel N	Channel N	Channel N	Channel N
4	Channel $\bar{N}$	Channel $\bar{N}$	N.C.	Channel $\bar{N}$
5	Channel A	Channel A	Channel A	Channel A
6	Channel $\bar{A}$	Channel $\bar{A}$	N.C.	Channel $\bar{A}$
7	N.C.	Alarm	Alarm	Alarm
8	Channel B	Channel B	Channel B	Channel B
9	N.C. <sup>1</sup>	N.C. <sup>1</sup>	N.C. <sup>1</sup>	N.C. <sup>1</sup>
10	GND	GND	GND	GND
11	Sense GND	N.C.	N.C.	N.C.
12	DC 5 V	DC 5/10 - 30 V	DC 10 - 30 V	DC 10 - 30 V

<sup>1</sup> screen for cable with CONIN connector

### ACCESSORIES

Hubshaft with tether as stator coupling: ordering code 1 531 162

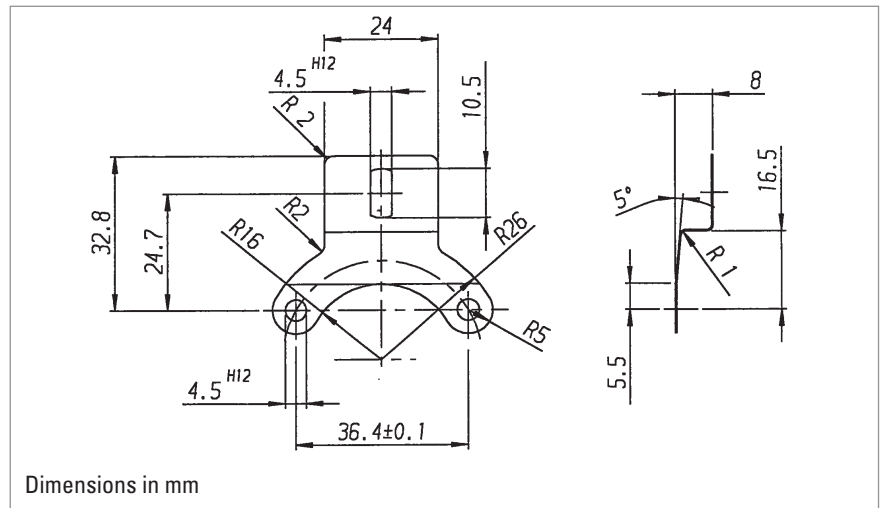

### ORDERING INFORMATION

Type	Model	Number of pulses	Supply voltage	Flange, Protection, Shaft	Output	Connection
<input type="checkbox"/>	<input type="checkbox"/>	<input type="text"/>	<input type="checkbox"/>	<input type="checkbox"/>	<input type="checkbox"/>	<input type="checkbox"/>
<b>RI58-</b>	<b>D</b> Hollow shaft <b>TD</b> Hollow shaft 100 °C	<b>1 ... 5 000</b>	<b>A</b> DC 5 V <sup>4</sup> <b>E</b> DC10 - 30 V <sup>5</sup> (only with push-pull)	<b>E.42</b> Blind shaft <sup>1</sup> , IP64/64, 10 mm <b>E.47</b> Blind shaft <sup>1</sup> , IP64/64, 12 mm <b>E.49</b> Blind shaft <sup>1</sup> , IP64/64, 14 mm <b>F.42</b> Blind shaft <sup>1</sup> , IP64/64, 10 mm <b>F.47</b> Blind shaft <sup>1</sup> , IP64/64, 12 mm <b>F.49</b> Blind shaft <sup>1</sup> , IP64/64, 14 mm <b>D.32</b> Clamping shaft front <sup>2</sup> , IP64/64, 10 mm <b>D.37</b> Clamping shaft front <sup>2</sup> , IP64/64, 12 mm	<b>K</b> push-pull <b>T</b> RS 422 + Sense <b>R</b> RS 422 + Alarm <b>I</b> push-pull complementary	<b>B</b> PVC cable radial <b>F</b> TPE cable radial <b>D</b> CONIN radial, cw <sup>3</sup> <b>H</b> CONIN radial, ccw <sup>3</sup>

<sup>1</sup> Mounting E, F: no through shaft (blind hole)

<sup>2</sup> through shaft, only connection cable

<sup>3</sup> only with mounting E or F (no through shaft)

<sup>4</sup> with output T, R

<sup>5</sup> with output K, I, R