

Features

- Bushing mount
- Optional AR pin feature
- Non-standard features and specifications available
- Gangable



Non-RoHS compliant versions are available until June 1, 2010.

3543/3545 - Precision Potentiometer

Electrical Characteristics ¹	3543 3-Turn	3545 5-Turn
Standard Resistance Range	20 to 50 K ohms	50 to 50 K ohms
Total Resistance Tolerance	±5 %	±5 %
Independent Linearity	±0.25 %	±0.25 %
Effective Electrical Angle	1080° +10°, -0°	1800° +10°, -0°
Absolute Minimum Resistance/Minimum Voltage	1 ohm or 0.1 % maximum (whichever is greater)	1 ohm or 0.1 % maximum (whichever is greater)
Noise	100 ohms ENR maximum	100 ohms ENR maximum
Dielectric Withstanding Voltage (MIL-STD-202, Method 301)		
Sea Level	1,000 VAC minimum	1,000 VAC minimum
Power Rating (Voltage Limited By Power Dissipation or 224 VAC [3543] or 273 VAC [3545], Whichever Is Less)		
+70 °C	1 watt	1.5 watt
+125 °C	0 watt	0 watt
Insulation Resistance (500 VDC)	1,000 megohms minimum	1,000 megohms minimum
Resolution	See recommended part nos.	See recommended part nos.

Environmental Characteristics ¹		
Operating Temperature Range	+1 °C to +125 °C	+1 °C to +125 °C
Storage Temperature Range	-55 °C to +125 °C	-55 °C to +125 °C
Temperature Coefficient Over		
Storage Temperature Range ²	±50 ppm/°C maximum/unit	±50 ppm/°C maximum/unit
Vibration	15 G	15 G
Wiper Bounce	0.1 millisecond maximum	0.1 millisecond maximum
Shock	50 G	50 G
Wiper Bounce	0.1 millisecond maximum	0.1 millisecond maximum
Load Life	1,000 hours, 1 watt	1,000 hours, 1.5 watts
Total Resistance Shift	±2 % maximum	±2 % maximum
Rotational Life (No Load)	300,000 shaft revolutions	500,000 shaft revolutions
Total Resistance Shift	±5 % maximum	±5 % maximum
Moisture Resistance (MIL-STD-202, Method 103, Condition B)		
Total Resistance Shift	±2 % maximum	±2 % maximum
IP Rating	IP 40	IP 40

Mechanical Characteristics ¹		
Stop Strength		53 N-cm (75 oz.-in.) min.
Mechanical Angle	1080° +10°, -0° (3543); 1800° +10°, -0° (3545)	
Torque (Starting & Running)		0.35 N-cm (0.5 oz.-in.) max.
Mounting		170-200 N-cm (15-18 lb.-in.)
Shaft Runout		0.08 mm (0.003 in.) T.I.R.
Lateral Runout		0.13 mm (0.005 in.) T.I.R.
Shaft End Play		0.25 mm (0.010 in.) T.I.R.
Shaft Radial Play		0.08 mm (0.003 in.) T.I.R.
Pilot Diameter Runout		0.08 mm (0.003 in.) T.I.R.
Backlash		1.0° maximum
Weight		Approximately 21 gm
Terminals		Gold-plated solder lugs

Soldering Condition
 Manual Soldering 96.5Sn/3.0Ag/0.5Cu solid wire or no-clean rosin cored wire; 370 °C (700 °F) max. for 3 seconds
 Wave Soldering 96.5Sn/3.0Ag/0.5Cu solder with no-clean flux; 260 °C (500 °F) max. for 5 seconds
 Wash processes Not recommended
 Marking Manufacturer's name and part number, resistance value and tolerance, linearity tolerance, wiring diagram, and date code.
 Ganging (Multiple Section Pots.) 2 cups maximum
 Hardware One lockwasher (H-37-2) and one mounting nut (H-38-2) is shipped with each potentiometer.

¹At room ambient: +25 °C nominal and 50 % relative humidity nominal, except as noted.
²Consult manufacturer for complete specification details.

Recommended Part Numbers

Part Number	Resistance (Ω)	Resolution (%)
3543S-1-102L	1,000	.077
3543S-1-202L	2,000	.062
3543S-1-502L	5,000	.047
3543S-1-103L	10,000	.040

Part Number	Resistance (Ω)	Resolution (%)
3545S-1-102L	1,000	.043
3545S-1-202L	2,000	.044
3545S-1-502L	5,000	.038
3545S-1-103L	10,000	.029

Product Dimensions

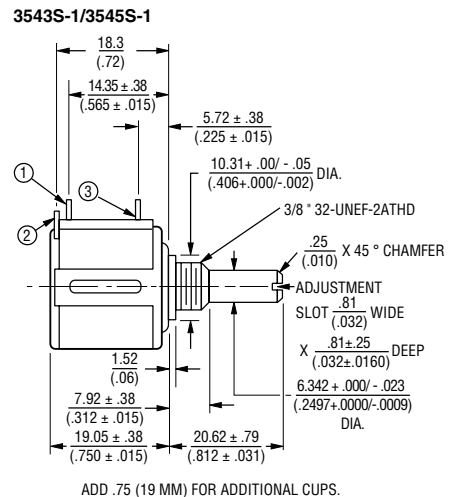

ADD .75 (19 MM) FOR ADDITIONAL CUPS.

OPTIONAL ANTIROTATION LUG
 (-.91) 1.42 X .50 ON 7.4 RADIUS
 (.056 X .02) (.29)
 LENGTH 1.27 FROM MOUNTING SURFACE.
 (SUGGESTED PANEL HOLE 1.6 DIA.)
 (.063)

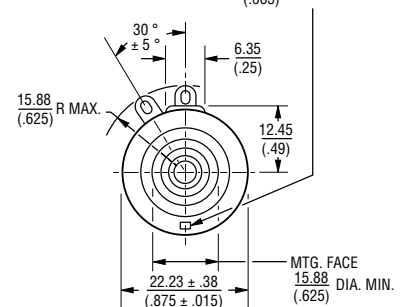

TOLERANCES: EXCEPT WHERE NOTED
 DECIMALS: .XX ± .25 (0.10), .XXX ± .13 (0.005)
 FRACTIONS: ±1/64
 DIMENSIONS: MM (IN.)

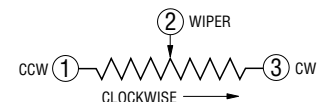

BOLDFACE LISTINGS ARE IN STOCK AND READILY AVAILABLE THROUGH DISTRIBUTION.

FOR SERVO MOUNT VERSION AND OTHER OPTIONS CONSULT FACTORY.

ROHS IDENTIFIER:
 L = COMPLIANT
 BLANK = NON-COMPLIANT

*RoHS Directive 2002/95/EC Jan 27 2003 including Annex Specifications are subject to change without notice. Customers should verify actual device performance in their specific applications.

3543/3545 - Precision Potentiometer

BOURNS®

Panel Thickness Dimensions

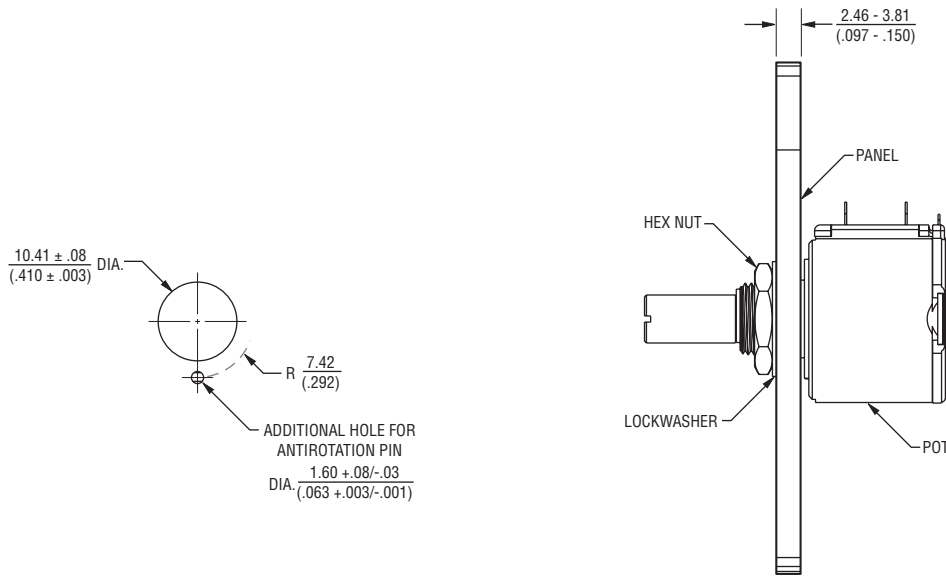

DIMENSIONS: $\frac{\text{MM}}{\text{(INCHES)}}$

TOLERANCES: $\pm \frac{0.127}{(.005)}$

REV. 11/09

Specifications are subject to change without notice.
Customers should verify actual device performance in their specific applications.



Features

- Bushing mount
- Optional AR pin feature
- Non-standard features and specifications available
- Gangable

BOURNS®

3543/3545 - Precision Potentiometer

	3543 3-Turn	3545 5-Turn
--	----------------	----------------

Electrical Characteristics ¹		
Standard Resistance Range	20 to 50K ohms	50 to 50K ohms
Resistance Tolerance	±5%	±5%
Independent Linearity	±0.25%	±0.25%
Resolution	See recommended part numbers	See recommended part numbers
Effective Electrical Angle	1080° +10°, -0°	1800° +10°, -0°
Absolute Minimum Resistance/	1 ohm or 0.1% maximum	1 ohm or 0.1% maximum
Minimum Voltage	(whichever is greater)	(whichever is greater)
Noise	100 ohms ENR maximum	100 ohms ENR maximum
Power Rating (Voltage Limited)		
By Power Dissipation or		
224 VAC [3543] or 273 VAC		
[3545], Whichever Is Less		
+70°C	1 watt	1.5 watt
+125°C	0 watt	0 watt
Dielectric Withstanding Voltage	MIL-STD-202, Method 301	MIL-STD-202, Method 301
Sea Level	1,000 VAC minimum	1,000 VAC minimum
Insulation Resistance		
(500 VDC)	1,000 megohms minimum	1,000 megohms minimum

Environmental Characteristics ¹		
Operating Temperature		
Static Operation Temp Range	-55°C to +125°C	-55°C to +125°C
Dynamic Temp Range	+1°C to +125°C	+1°C to +125°C
Temperature Coefficient ²	±50ppm/°C maximum/unit	±50ppm/°C maximum/unit
Vibration	15G	15G
Wiper Bounce	0.1 millisecond maximum	0.1 millisecond maximum
Shock	50G	50G
Wiper Bounce	0.1 millisecond maximum	0.1 millisecond maximum
Load Life	1,000 hours, 1 watt	1,000 hours, 1.5 watts
Total Resistance Shift	±2% maximum	±2% maximum
Rotational Life (No Load)	300,000 shaft revolutions	500,000 shaft revolutions
Total Resistance Shift	±5% maximum	±5% maximum
Moisture Resistance	MIL-STD-202, Method 103, Condition B	MIL-STD-202, Method 103, Condition B
Total Resistance Shift	±2% maximum	±2% maximum

Mechanical Characteristics ¹		
Mechanical Angle	1080° +10°, -0°	1800° +10°, -0°
Shaft Runout	0.003 in. (0.08mm) T.I.R.	0.003 in. (0.08mm) T.I.R.
Lateral Runout	0.005 in. (0.13mm) T.I.R.	0.005 in. (0.13mm) T.I.R.
Pilot Diameter Runout	0.003 in. (0.08mm) T.I.R.	0.003 in. (0.08mm) T.I.R.
Shaft End Play	0.010 in. (0.25mm) T.I.R.	0.010 in. (0.25mm) T.I.R.
Shaft Radial Play	0.003 in. (0.08mm) T.I.R.	0.003 in. (0.08mm) T.I.R.
Stop Strength	75 oz.-in. (53 Ncm) min.	75 oz.-in. (53 Ncm) min.
Torque (Starting & Running)	0.5 oz.-in. (0.35 Ncm) max.	0.5 oz.-in. (0.35 Ncm) max.
Weight	Approximately 21G	Approximately 21G
Terminals	Gold-plated solder lugs	Gold-plated solder lugs
Backlash	1.0° maximum	1.0° maximum
Ganging	2 cups maximum	2 cups maximum

¹At room ambient: +25°C nominal and 50% relative humidity nominal, except as noted.
²Consult manufacturer for complete specification details.

Recommended Part Numbers

Part Number*	Resistance (Ω)	Resolution (%)
3543S-1-102	1,000	.063
3543S-1-202	2,000	.062
3543S-1-502	5,000	.047
3543S-1-103	10,000	.040

Part Number	Resistance (Ω)	Resolution (%)
3545S-1-102	1,000	.043
3545S-1-202	2,000	.036
3545S-1-502	5,000	.038
3545S-1-103	10,000	.027

3543S-1/3545S-1

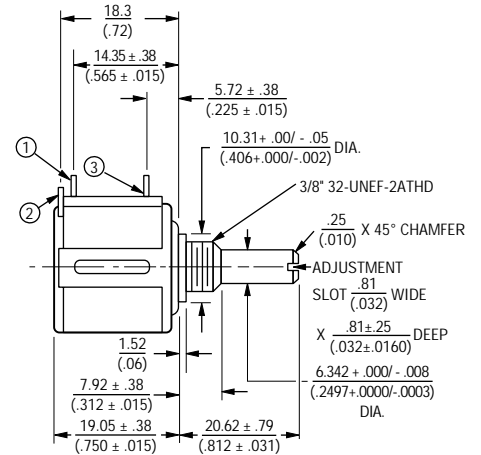

NOTE: LOCKWASHER AND MOUNTING NUTS SUPPLIED.
 ADD .75 (19MM) FOR ADDITIONAL CUPS.

OPTIONAL ANTIROTATION LUG
 (-91) 1.42 X .50 ON 7/4 RADIUS
 (.056 X .02) (.29)
 LENGTH 1.27 FROM MOUNTING SURFACE.
 (SUGGESTED PANEL HOLE 1.6 DIA.)
 (.063)

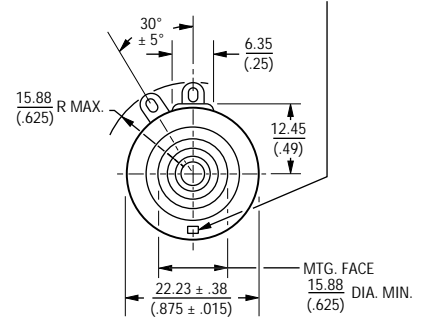

TOLERANCES: EXCEPT WHERE NOTED
 DECIMALS: XX ± .25 (0.010), XXX ± .13 (0.005)
 FRACTIONS: ±1/64
 DIMENSIONS: MM (IN.)

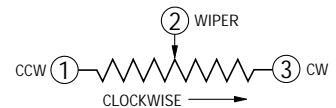



7/8" ϕ , 3-, 5-, 10-TURN BUSHING MOUNT POTENTIOMETERS WIREWOUND ELEMENT

- Space saving size: extends 3/4" behind panel only
 - High performance at low cost
 - $\pm 0.1\%$ linearity
 - Front and rear shaft extensions
 - Anti rotation lug
 - Two sections with common or concentric shafts
- OPTIONAL FEATURES
- High shaft torque
 - $\pm 1\%$ resistance tolerance

STANDARD SPECIFICATIONS	MODEL 3540 10 Turn	MODEL 3543 3 Turn	MODEL 3545 5 Turn
Electrical Characteristics			
Resistance Range	100 Ω – 100K Ω	20 Ω – 50K Ω	50 Ω – 50K Ω
Resistance Tolerance	$\pm 5\%$		
Linearity (Independent)	$\pm 0.25\%$		
Resolution	See ordering information		
Effective Electrical Angle	3600° +10° – 0°	1080° +10° – 0°	1800° +10° – 0°
Absolute Minimum Resistance	1 Ω or 0.1%, whichever is greater		
Noise	100 Ω ENR max.		
Power Rating			
70°C	2.0 W	1.0 W	1.5 W
125°C		0 W	
Second Section (-135 or -468) 70°C	1.5 W	0.75 W	1.0 W
Dielectric Strength MIL-R-12934			
Sea Level	1000 V ~ min.		
Insulation Resistance 500 V =	1000 Meg. Ω min.		
Environmental Characteristics			
Operating Temperature Range	–55°C to +125°C		
Temperature Coefficient of Wire	20 ppm/°C max.		
Vibration	MIL-R-12934, 15G		
Wiper Bounce	0.1 millisecond max.		
Shock	MIL-R-12934, 50G		
Wiper Bounce	0.1 millisecond max.		
Load Life MIL-R-12934	1000 hours		
Resistance Shift	2.0% max.		
Mechanical and Physical Characteristics			
Mechanical Angle	3600° +10° – 0°	1080° +10° – 0°	1800° +10° – 0°
Shaft Runout	0.003 in. T. I. R.		
Lateral Runout	0.005 in. T. I. R.		
Pilot Diameter Runout	0.003 in. T. I. R.		
Shaft End Play	0.010 in. T. I. R.		
Shaft Radial Play	0.003 in. T. I. R.		
Rotational Life, shaft revolutions	1,000,000	300,000	500,000
Stop Strength	75 oz.-in. min.		
Torque, Starting and Running	0.5 oz.-in. max.		
Weight	approx. 21 g		
Terminals	Gold-plated solder lugs		

NOTES: Consult Bourns representative for complete specification details for resistance below 200 Ω .

Specifications are subject to change without notice.

BOURNS®

ORDERING INFORMATION						
Resistance Ω	Part Number*	Resolution %	Part Number*	Resolution %	Part Number*	Resolution %
20	—	—	3543S-1-200	0.169	—	—
50	—	—	3543S-1-500	0.148	3545S-1-500	0.110
100	● 3540S-1-101	0.055	3543S-1-101	0.127	3545S-1-101	0.084
200	● 3540S-1-201	0.042	3543S-1-201	0.110	3545S-1-201	0.069
500	● 3540S-1-501	0.031	3543S-1-501	0.077	3545S-1-501	0.054
1,000	● 3540S-1-102	0.027	● 3543S-1-102	0.077	● 3545S-1-102	0.043
2,000	● 3540S-1-202	0.021	3543S-1-202	0.062	3545S-1-202	0.044
5,000	● 3540S-1-502	0.021	● 3543S-1-502	0.047	● 3545S-1-502	0.038
10,000	● 3540S-1-103	0.019	● 3543S-1-103	0.040	● 3545S-1-103	0.029
20,000	● 3540S-1-203	0.014	3543S-1-203	0.031	3545S-1-203	0.023
50,000	● 3540S-1-503	0.011	3543S-1-503	0.024	3545S-1-503	0.017
100,000	● 3540S-1-104	0.008	—	—	—	—

*The last three digits of the part number represent the resistance in standard code.

● Preferred resistance values

NOTES: Available with Hybritron® element

DIMENSIONS (INCH)

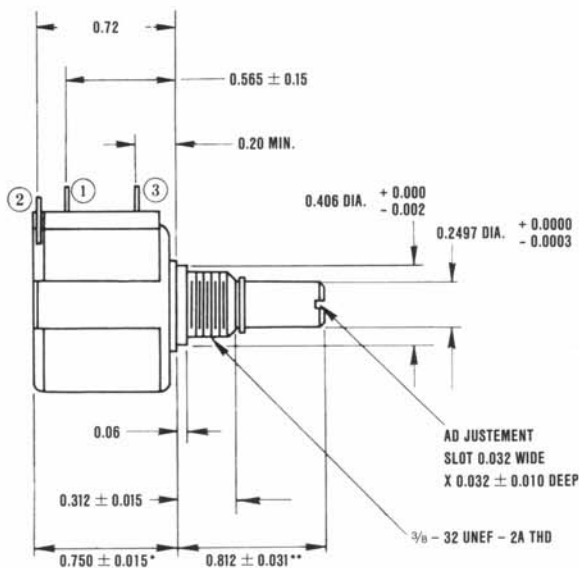

*ADD 0.745" FOR SECOND SECTION (3540-135 or 3540-468)

**ADD 0.5" FOR 0.1248" DIA. INNER (REAR SECTION) CONCENTRIC SHAFT (3540-468)

NOTE:
LOCKWASHER & HEX NUT TO BE
SUPPLIED WITH UNIT.

TOLERANCES: XX = ± 0.01
.XXX = ± 0.005 EXCEPT
WHERE NOTED

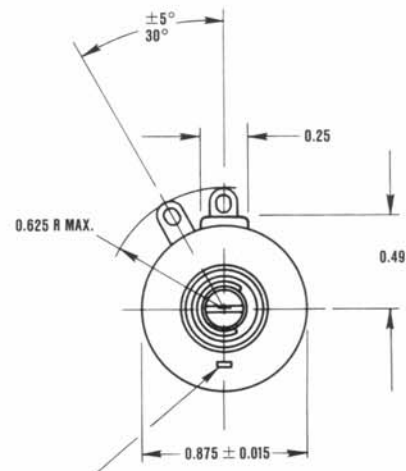

OPTIONAL
ANTI-ROTATION LUG (-91)
0.056 x 0.02 ON
0.29 RADIUS,
LENGTH 0.05
FROM MOUNTING
SURFACE
(SUGGESTED PANEL HOLE 0.063 DIA.)

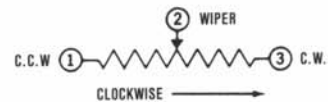

Specifications are subject to change without notice.

BOURNS®

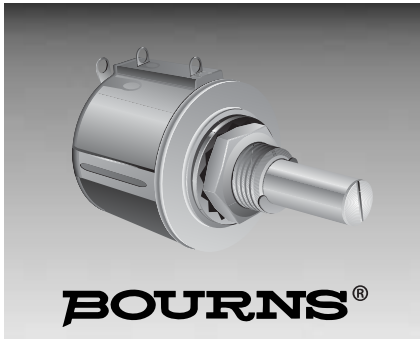

Features

- Bushing mount
- Optional AR pin feature
- Non-standard features and specifications available
- Gangable

BOURNS®

3543/3545 - Precision Potentiometer

Electrical Characteristics ¹	3543 3-Turn	3545 5-Turn
Standard Resistance Range	20 to 50 K ohms	50 to 50 K ohms
Total Resistance Tolerance	±5 %	±5 %
Independent Linearity	±0.25 %	±0.25 %
Effective Electrical Angle	1080° +10°, -0°	1800° +10°, -0°
Absolute Minimum Resistance/ Minimum Voltage	1 ohm or 0.1 % maximum (whichever is greater)	1 ohm or 0.1 % maximum (whichever is greater)
Noise	100 ohms ENR maximum	100 ohms ENR maximum
Dielectric Withstanding Voltage (MIL-STD-202, Method 301) Sea Level	1,000 VAC minimum	1,000 VAC minimum
Power Rating (Voltage Limited By Power Dissipation or 224 VAC [3543] or 273 VAC [3545], Whichever Is Less)		
+70 °C	1 watt	1.5 watt
+125 °C	0 watt	0 watt
Insulation Resistance (500 VDC)	1,000 megohms minimum	1,000 megohms minimum
Resolution	See recommended part nos.	See recommended part nos.

Environmental Characteristics ¹		
Operating Temperature Range	+1 °C to +125 °C	+1 °C to +125 °C
Storage Temperature Range	-55 °C to +125 °C	-55 °C to +125 °C
Temperature Coefficient Over Storage Temperature Range ²	±50 ppm/°C maximum/unit	±50 ppm/°C maximum/unit
Vibration	15 G	15 G
Wiper Bounce	0.1 millisecond maximum	0.1 millisecond maximum
Shock	50 G	50 G
Wiper Bounce	0.1 millisecond maximum	0.1 millisecond maximum
Load Life	1,000 hours, 1 watt	1,000 hours, 1.5 watts
Total Resistance Shift	±2 % maximum	±2 % maximum
Rotational Life (No Load)	300,000 shaft revolutions	500,000 shaft revolutions
Total Resistance Shift	±5 % maximum	±5 % maximum
Moisture Resistance (MIL-STD-202, Method 103, Condition B)		
Total Resistance Shift	±2 % maximum	±2 % maximum
IP Rating	IP 40	IP 40

Mechanical Characteristics ¹		
Stop Strength	53 N-cm (75 oz.-in.) min.	
Mechanical Angle	1080° +10°, -0° (3543); 1800° +10°, -0° (3545)	
Torque (Starting & Running)	0.35 N-cm (0.5 oz.-in.) max.	
Mounting	170-200 N-cm (15-18 lb.-in.)	
Shaft Runout	0.08 mm (0.003 in.) T.I.R.	
Lateral Runout	0.13 mm (0.005 in.) T.I.R.	
Shaft End Play	0.25 mm (0.010 in.) T.I.R.	
Shaft Radial Play	0.08 mm (0.003 in.) T.I.R.	
Pilot Diameter Runout	0.08 mm (0.003 in.) T.I.R.	
Backlash	1.0° maximum	
Weight	Approximately 21 gm	
Terminals	Gold-plated solder lugs	
Soldering Condition	Recommended hand soldering using Sn95/Ag5 no clean solder, 0.025 " wire diameter. Maximum temperature 399 °C (750 °F) for 3 seconds. No wash process to be used with no clean flux.	
Marking	Manufacturer's name and part number, resistance value and tolerance, linearity tolerance, wiring diagram, and date code.	
Ganging (Multiple Section Pots.)	2 cups maximum	
Hardware	One lockwasher (H-37-2) and one mounting nut (H-38-2) is shipped with each potentiometer.	

¹At room ambient: +25 °C nominal and 50 % relative humidity nominal, except as noted.
²Consult manufacturer for complete specification details.

Recommended Part Numbers

Part Number*	Resistance (Ω)	Resolution (%)
3543S-1-102	1,000	.077
3543S-1-202	2,000	.062
3543S-1-502	5,000	.047
3543S-1-103	10,000	.040

Part Number	Resistance (Ω)	Resolution (%)
3545S-1-102	1,000	.043
3545S-1-202	2,000	.044
3545S-1-502	5,000	.038
3545S-1-103	10,000	.029

3543S-1/3545S-1

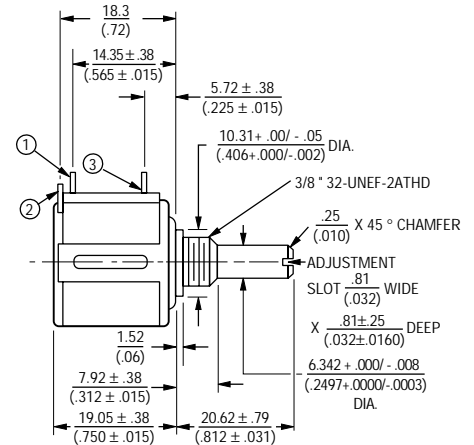

ADD .75 (19 MM) FOR ADDITIONAL CUPS.

OPTIONAL ANTIROTATION LUG
(-91) 1.42 X .50 ON 7.4 RADIUS
(.056 X .02) ON .29
LENGTH 1.27 FROM MOUNTING SURFACE.
(SUGGESTED PANEL HOLE 1.6 DIA.)
(.063)

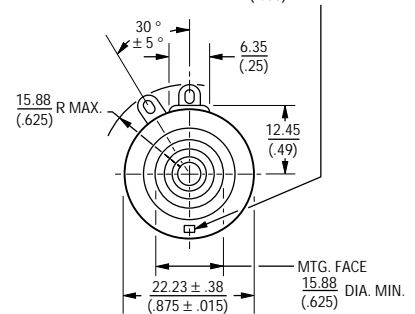

TOLERANCES: EXCEPT WHERE NOTED

DECIMALS: XX ± .25 (0.010), XXX ± .13 (0.005)

FRACTIONS: ±1/64

DIMENSIONS: MM (IN.)

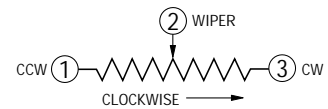

BOLDFACE LISTINGS ARE IN STOCK AND READILY AVAILABLE THROUGH DISTRIBUTION.

FOR SERVO MOUNT VERSION AND OTHER OPTIONS CONSULT FACTORY.

MATERIAL DATA SHEET



Reliable Electronic Solutions

Material #	3545S-1	
Product Line	Precisions	
Posted Date	03/02/2005	
Compliance Date	Since Inception	
RoHS Compliant	Yes	

No.	Construction element	Material group	Material weight [g]	Materials	CAS If applicable	Average mass [%]	Sum [%]
1	Mandrel Wire	Metal Alloy	2.255	Copper	7440-50-8	92-99%	9.7989%
				Organic coatings	*****	1-8%	
2	Resist Wire	Nickel Alloy	0.5226	Nickel	7440-02-0	27-47%	2.2709%
				Copper	7440-50-8	Balance	
				Iron	1300-37-1	Max 3%	
				Manganese	7439-96-5	Max 3%	
				Cobalt	7440-48-4	Max 0.5%	
3	Varnish	Insulating Varnish	0.2569	Phenolic Resin	UNK00185	100%	1.1163%
4	Housing Molded	PBT	2.654	Glass	65997-17-3	10-30%	11.5327%
				PBT	*****	65-89%	
				Antimony Oxide	1309-64-4	1-5%	
5	Terminal Cover Molded	PBT	0.2905	Glass	65997-17-3	10-30%	1.2623%
				PBT	*****	65-89%	
				Antimony Oxide	1309-64-4	1-5%	
				Carbon Black	1333-86-4	0.1-1%	
6	Terminals	Brass Alloy	0.0375	Copper	7440-50-8	59-96%	0.1630%
				Zinc	7440-66-6	4-41%	
				Lead	7439-92-1	0.03-0.3%	
7	Hex Nut	Brass Alloy	1.179	Copper	7440-50-8	55.5-86%	5.1232%
				Zinc	7440-66-6	13.90-42.5%	
				Lead	7439-92-1	.00-3.7%	
				Tin	7440-31-5	.00-1.2%	
				Aluminum	7429-90-5	.00-2.3%	
				Manganese	7439-96-5	.00-3.5%	
				Silicon	7440-21-3	.00-1.5%	



Reliable Electronic Solutions

8	Lock Washer	Steel Alloy	0.2945	Nickel	7440-02-0	.00-.02%	1.2797%
				Carbon	7440-11-0	0.51%	
				Manganese	7439-98-5	0.75%	
				Phosphorus	7723-14-0	0.02%	
				Sulfur	7704-39-9	0.025%	
				Iron	7439-89-6	98.695%	
		Chromium	16065-83-1	0.1%			
		Zinc Coating	0.002975	Tin	7440-31-5	0.64%	0.0129%
		Zinc	7440-66-6	99.25%			
9	SS Washer	Steel Alloy	0.008	Iron	7493-89-6	52-78%	0.0348%
				Chromium	7440-47-3	12-24%	
				Nickel	7440-02-0	6.0-19%	
				Molybdenum	7439-98-7	0-5.0%	
				Silicon	7440-21-3	0-6%	
				Manganese	7439-96-3	0-2.0%	
				Tungsten	7440-33-7	0-1.8%	
				Aluminum	7429-90-5	0-1.5%	
				Columbium	7440-03-1	0-1.0%	
				Titanium	7440-32-6	0-0.7%	
				Copper	7440-50-8	0.075%	
				Cobalt	7440-48-4	0.1.0%	
				10	Ink - Printing	Hybritron Ink	
Formaldehyde	50-00-0	<2 %					
Xylene	1330-20-7	30%					
Blend of Allyl Resin & Diallyl	*****	20%					
Carbon	7440-44-0	<14%					
11	Lube	Fluorosilicone Grease	0.05463	Polysiloxane	*****	100%	0.2374%
12	C-Ring	Stainless Steel Alloy	0.009	Iron	7439-89-6	48-89%	0.0391%
				Chromium	7440-47-3	10-27%	
				Nickel	7440-02-0	0-22%	
				Manganese	7439-96-5	0-15%	
				Tungsten	7440-33-7	0-4%	
				Molybdenum	7439-98-7	0-4%	
				Aluminum	7429-90-5	0-2%	
				Copper	7440-50-8	0-4%	
Silicon	7440-51-3	0-5%					



Reliable Electronic Solutions

				Cobalt	7440-48-4	0-5%	
13	Bushing	Aluminum Alloy	1.1765	Aluminum	7429-90-5	100%	5.1124%
14	Rotor Molded	PBT	1.325	Glass	65997-17-3	10-30%	5.7577%
				PBT	*****	65-89%	
				Antimony Oxide	1309-64-4	1-5%	
15	Shaft	Brass Alloy	9.1625	Copper	7440-50-8	70%	39.8148%
				Zinc	7440-66-6	30%	
16	Spring Contact Rough	Metal Alloy	0.006	Silver	7440-22-4	30.0%	0.0261%
				Copper	7440-50-8	14.0%	
				Zinc	7440-66-6	1.0%	
				Platinum	7440-06-4	10.0%	
17	Collector Bar	Nickel Silver Alloy	0.065	Copper	7440-50-8	50-80%	0.2825%
				Nickel	7440-02-0	7-19.5%	
				Lead	7439-92-1	0-2.5%	
				Zinc	7440-66-6	Remainder	
18	Strap	Copper, Nickel, Zinc Alloy	2.303	Copper	7440-50-8	53.5-71.0%	10.0075%
				Lead	7439-92-1	0.1	
				Nickel	7439-02-0	21.0	
				Zinc	7440-66-6	13.24-32.0%	
19	Cover Molded	PBT	0.7005	Glass	65997-17-3	10-30%	3.0440%
				PBT	*****	65-89%	
				Antimony Oxide	1309-64-4	1-5%	
20	Terminals Wiper	Brass Alloy	0.3	Copper	7440-50-8	59-96%	1.3036%
				Zinc	7440-66-6	4-41%	
				Lead	7439-92-1	0.03-0.3%	
21	Slider Molded	PBT	0.193	Glass	65997-17-3	10-30%	0.8387%
				PBT	*****	65-89%	
				Antimony Oxide	1309-64-4	1-5%	
22	Slider Molded	PBT	0.193	Glass	65997-17-3	10-30%	0.8387%
				PBT	*****	65-89%	
				Antimony Oxide	1309-64-4	1-5%	
		Total weight	23.012806				