



## 7/8" $\phi$ , 10-TURN BUSHING MOUNT POTENTIOMETERS HYBRITRON® ELEMENT

- Extended resistance range
- Long rotational life element provides essentially infinite resolution
- Housing: high temperature, moisture resistant, thermo-setting plastic.
- Outstanding resistance to humidity
- Performance guaranteed by Bourns Reliability Assurance Program which includes individual inspection to published electrical and physical characteristics

STANDARD SPECIFICATIONS	MODEL 3501 7/8" $\phi$
<b>Electrical Characteristics</b>	
Resistance Range	1 K $\Omega$ – 100 K $\Omega$
Resistance Tolerance	$\pm 10\%$
Linearity (Independent)	$\pm 0.2\%$
Resolution	essentially infinite
Effective Electrical Angle	3600° + 10° – 0°
End Voltage	0.1% max.
Output Smoothness	0.05%
Power Rating	2.0 W
	0 W
<b>Dielectric Strength MIL-R-39023</b>	
Sea Level	1500 V ~
80,000 feet	400 V ~
Insulation Resistance 500 V =	1000 Meg. $\Omega$ min.
<b>Environmental Characteristics</b>	
Operating Temperature Range	-65 °C to +125 °C
Temperature Coefficient	$\pm 100$ ppm/°C
Humidity	MIL-R-39023 moisture resistance
Vibration	MIL-R-39023, 20G
Wiper Bounce	0.1 millisecond max.
Wiper Shift	0.1% max.
Shock	MIL-R-39023, 100G
Wiper Bounce and Wiper Shift	Same as Vibration
Load Life MIL-R-39023	1000 hours
Sand, Dust, Fungus	MIL-E-5272
Salt Spray	MIL-R-39023
<b>Mechanical and Physical Characteristics</b>	
Mechanical Angle	3600° + 10° – 0°
Shaft Runout	0.002 in. T.I.R.
Shaft End Play	0.005 in. T.I.R.
Shaft Radial Play	0.003 in. T.I.R.
Rotational Life, shaft revolutions	4,000,000
Torque, Starting and Running	0.6 oz.-in. max.
Stop Strength	96 oz.-in. min.
Ganging	2 cups max.
Weight	approx. 28 g
Terminals	Gold plated solder lugs
Markings	Manufacturer's name and part number, resistance value and tolerance, Linearity tolerance, wiring diagram, date code

Specifications are subject to change without notice.

# BOURNS®

## ORDERING INFORMATION

Resistance $\Omega$	Part Number*
1,000	● 3501H-1-102
2,000	3501H-1-202
5,000	● 3501H-1-502
10,000	● 3501H-1-103
20,000	3501H-1-203
50,000	3501H-1-503
100,000	3501H-1-104

● Preferred resistance values

\*The last three digits of the part number represent the resistance in standard code.

## DIMENSIONS (INCH)

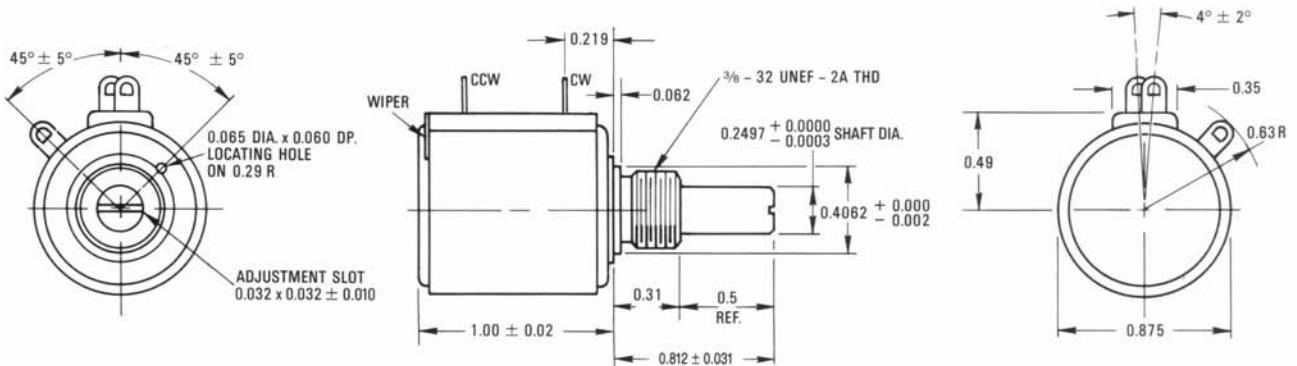

NOTE:  
LOCKWASHER & HEX NUT TO BE  
SUPPLIED WITH UNIT.

TOLERANCES: .XX =  $\pm 0.01$   
.XXX =  $\pm 0.005$  EXCEPT  
WHERE NOTED

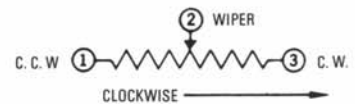

Specifications are subject to change without notice.

# BOURNS®



### 7/8" $\phi$ , 3-, 5-, 10-TURN BUSHING MOUNT POTENTIOMETERS WIREWOUND ELEMENT

- SILVERWELD® termination eliminates vulnerable single wire termination
- High temperature performance
- Outstanding resistance to humidity. Exceeds humidity cycling requirements of MIL-R-12934
- Housing: high temperature, moisture resistant, thermosetting plastic
- 100% contact pressure control assures low noise and long rotational life
- Performance guaranteed by Bourns Reliability Assurance Program which includes individual inspection to published electrical and physical characteristics

STANDARD SPECIFICATIONS	MODEL 3500 10 Turn	MODEL 3510 3 Turn	MODEL 3520 5 Turn
<b>Electrical Characteristics</b>			
Resistance Range	50 $\Omega$ – 200 K $\Omega$	50 $\Omega$ – 50 K $\Omega$	50 $\Omega$ – 50 K $\Omega$
Resistance Tolerance		$\pm 3\%$	
Linearity (Independent)	$\pm 0.2\%$	$\pm 0.3\%$	$\pm 0.3\%$
Resolution	See ordering information		
Effective Electrical Angle	3600°+10°–0°	1080°+10°–0°	1800°+10°–0°
Absolute Minimum Resistance	1 $\Omega$ or 0.1%, whichever is greater		
Noise	100 $\Omega$ ENR max.		
Power Rating	70°C 125°C	2.0 W 1.0 W 0 W	1.5 W
<b>Dielectric Strength MIL-R-12934</b>			
Sea Level	1500 V ~ min.		
80,000 feet	400 V ~ min.		
Insulation Resistance 500 V =	1000 Meg. $\Omega$ min.		
<b>Environmental Characteristics</b>			
Operating Temperature Range	– 65°C to +125°C		
Temperature Coefficient of Wire①	20 ppm/°C max.		
Humidity	MIL-R-12934 Humidity Cycling		
Vibration	MIL-R-12934, 20G		
Wiper Bounce	0.1 millisecond max.		
Wiper Shift	0.1% max.		
Shock	MIL-R-12934, 100G		
Wiper Bounce and Wiper Shift	Same as Vibration		
Load Life MIL-R-12934	1000 hours		
Resistance Shift	2.0% max.		
Sand, Dust, Fungus	MIL-E-5272		
Salt Spray	MIL-R-12934		
<b>Mechanical and Physical Characteristics</b>			
Mechanical Angle	3600°+10°–0°	1080°+10°–0°	1800°+10°–0°
Shaft Runout	0.002 in. T. I. R.		
Lateral Runout	0.005 in. T. I. R.		
Pilot Diameter Runout	0.002 in. T. I. R.		
Shaft End Play	0.005 in. T. I. R.		
Shaft Radial Play	0.003 in. T. I. R.		
Rotational Life, shaft revolutions	2,000,000	600,000	1,000,000
Stop Strength	96 oz.-in. min.	48 oz.-in. min.	48 oz.-in. min.
Torque Starting/Running	0.6 oz.-in. max.		
Backlash	1.0° max.		
Ganging	2 cups max.		

Specifications are subject to change without notice.

# BOURNS®

STANDARD SPECIFICATIONS CONT.	MODEL 3500 10 Turn	MODEL 3510 3 Turn	MODEL 3520 5 Turn
Weight	approx. 28 g	approx. 20 g	approx. 20 g
Terminals	Gold-plated solder lugs		
Markings*	Manufacturer's name and part number, resistance value and tolerance, linearity tolerance, wiring diagram and date code.		

NOTES: ① Consult Bourns representative for complete specification details for resistances below 200 Ω and above 50 KΩ (3510), 125 KΩ (3500), 75 KΩ (3520).  
Available with Hybritron® element.

ORDERING INFORMATION						
Resistance Ω	Part Number*	Resolution %	Part Number*	Resolution %	Part Number*	Resolution %
50	3500S-2-500	0.058	3510S-1-500	0.140	3520S-1-500	0.08
100	3500S-2-101	0.053	3510S-1-101	0.113	3520S-1-101	0.08
200	3500S-2-201	0.044	3510S-1-201	0.092	3520S-1-201	0.07
500	3500S-2-501	0.033	3510S-1-501	0.071	3520S-1-501	0.05
1,000	● 3500S-2-102	0.030	● 3510S-1-102	0.059	● 3520S-1-102	0.04
2,000	3500S-2-202	0.024	3510S-1-202	0.059	3520S-1-202	0.05
5,000	● 3500S-2-502	0.018	● 3510S-1-502	0.047	● 3520S-1-502	0.035
10,000	● 3500S-2-103	0.016	● 3510S-1-103	0.037	● 3520S-1-103	0.03
20,000	3500S-2-203	0.015	3510S-1-203	0.028	3520S-1-203	0.025
50,000	3500S-2-503	0.011	3510S-1-503	0.022	3520S-1-503	0.02
100,000	3500S-2-104	0.008	—	—	—	—
200,000	3500S-2-204	0.007	—	—	—	—

\*The last three digits of the part number represent the resistance in standard code.

● Preferred resistance values

## DIMENSIONS (INCH)

3500

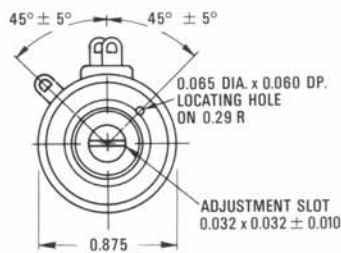

LOCKWASHER AND MOUNTING NUT SUPPLIED WITH EACH UNIT

3520

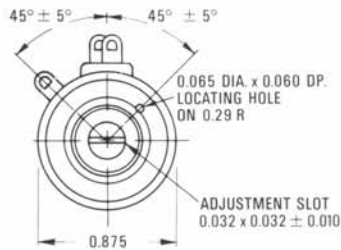

TOLERANCES:  
EXCEPT WHERE NOTED  
DECIMALS: .XX ± 0.010, .XXX ± 0.005

3510

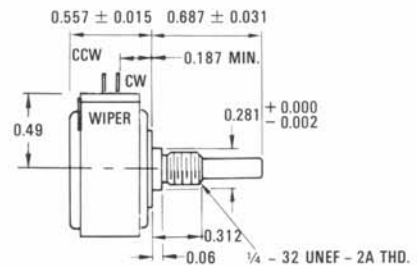
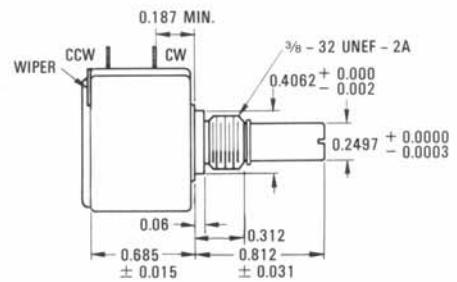
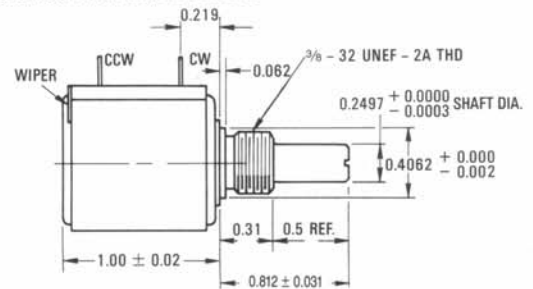
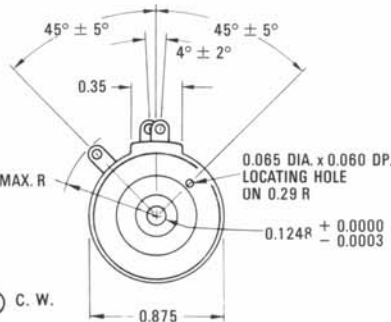
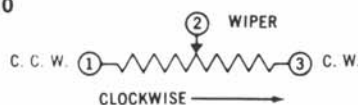

Specifications are subject to change without notice.

# BOURNS®



## Features

- Bushing mount
- Sealable
- Non-standard features and specifications available
- Optional high torque feature
- Optional center tap feature
- Gangable

## 3500/3501 - Precision Potentiometer

Electrical Characteristics <sup>1</sup>	3500 Wirewound Element	3501 Hybritron® Element
Standard Resistance Range	50 to 200 K ohms	1 K to 200 K ohms
Total Resistance Tolerance	±3 %	±10 %
Independent Linearity	±0.20 %	±0.25 %
Effective Electrical Angle	3600° +10°, -0°	3600° +10°, -2°
Absolute Minimum Resistance/ Minimum Voltage	1 ohm or 0.1 % maximum (whichever is greater)	0.2 % maximum
Noise	100 ohms ENR maximum	Output smoothness 0.1 % max.
Dielectric Withstanding Voltage (MIL-STD-202, Method 301)		
Sea Level	1,500 VAC minimum	1,500 VAC minimum
70,000 Feet	400 VAC minimum	400 VAC minimum
Power Rating (Voltage Limited By Power Dissipation or 325 VAC, Whichever Is Less)		
+70 °C	2 watts	2 watts
+125 °C	0 watt	0 watt
Insulation Resistance (500 VDC)	1,000 megohms minimum	1,000 megohms minimum
Resolution	See recommended part nos	Essentially infinite

Environmental Characteristics <sup>1</sup>		
Operating Temperature Range	+1 °C to +125 °C	+1 °C to +125 °C
Storage Temperature Range	-65 °C to +125 °C	-65 °C to +125 °C
Temperature Coefficient Over Storage Temperature Range <sup>2</sup>	±50 ppm/°C maximum/unit	±100 ppm/°C maximum/unit
Vibration	20 G	20 G
Wiper Bounce	0.1 millisecond maximum	0.1 millisecond maximum
Total Resistance Shift	±2 % maximum	±2 % maximum
Voltage Ratio Shift	±0.1 % maximum	±0.1 % maximum
Shock	100 G	100 G
Wiper Bounce	0.1 millisecond maximum	0.1 millisecond maximum
Total Resistance Shift	±2 % maximum	±2 % maximum
Voltage Ratio Shift	±0.1 % maximum	±0.1 % maximum
Load Life	1,000 hours, 2 watts	1,000 hours, 2 watts
Total Resistance Shift	±2 % maximum	±5 % maximum
Rotational Life (No Load)	2,000,000 shaft revolutions <sup>2</sup>	4,000,000 shaft revolutions
Total Resistance Shift	±5 % maximum	±5 % maximum
Moisture Resistance (MIL-STD-202, Method 103, Condition B)		
Total Resistance Shift	±2 % maximum	±5 % maximum
IP Rating	IP 65	IP 65

Mechanical Characteristics <sup>1</sup>	
Stop Strength	67.8 N-cm (96 oz.-in.) minimum
Mechanical Angle	3600° +10°, -0°
Torque (Starting & Running)	0.42 N-cm (0.6 oz.-in.) maximum
Mounting	170-200 N-cm (15-18 lb.-in.) maximum
Shaft Runout	0.05 mm (0.002 in.) T.I.R.
Lateral Runout	0.13 mm (0.005 in.) T.I.R.
Shaft End Play	0.13 mm (0.005 in.) T.I.R.
Shaft Radial Play	0.08 mm (0.003 in.) T.I.R.
Pilot Diameter Runout	0.05 mm (0.002 in.) T.I.R.
Backlash	1.0° maximum
Weight	Approximately 28 gm
Terminals	Gold-plated solder lugs
Soldering Condition	Recommended hand soldering using Sn95/Ag5 no clean solder, 0.025" wire diameter. Maximum temperature 399 °C (750 °F) for 3 seconds. No wash process to be used with no clean flux.
Marking	Manufacturer's name and part number, resistance value and tolerance, linearity tolerance, wiring diagram, and date code.
Ganging (Multiple Section Potentiometers)	2 cups maximum
Hardware	One lockwasher (H-37-2) and one mounting nut (H-38-2) is shipped with each potentiometer.

### Recommended Part Numbers

Part Number	Resistance (Ω)	Resolution
3500S-1-102	1,000	.030
3500S-1-502	5,000	.018
3500S-1-103	10,000	.019
3500S-2-102	1,000	.030
3500S-2-502	5,000	.018
3500S-2-103	10,000	.019

Part Number	Resistance (Ω)
3501H-1-102	1,000
3501H-1-502	10,000
3501H-1-103	10,000

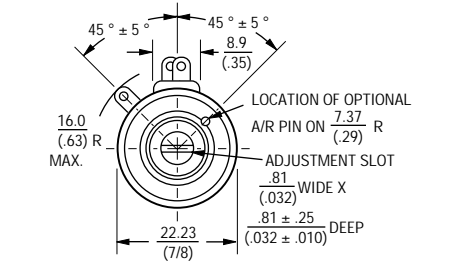
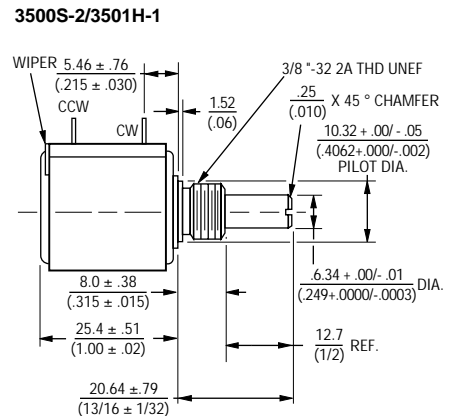

#### NOTE: SHAFT LENGTH VARIATIONS

3500S-1-RC	11/16 (17.46)	(plastic bushing)
3500S-2-RC	13/16 (20.64)	(metal bushing)
3501H-1-RC	13/16 (20.64)	(metal bushing)

#### TOLERANCES: EXCEPT WHERE NOTED

DECIMALS: XX ± .25 (0.010), XXX ± .13 (0.005)  
 FRACTIONS: ±1/64  
 DIMENSIONS: MM (IN.)

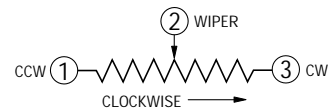

**BOLDFACE LISTINGS ARE IN STOCK AND READILY AVAILABLE THROUGH DISTRIBUTION.**

FOR OTHER OPTIONS CONSULT FACTORY.



## Features

- Bushing mount
- Sealable
- Non-standard features and specifications available
- Optional high torque feature
- Optional center tap feature

- Gangable

# 3500 - Precision Potentiometer

### Electrical Characteristics<sup>1</sup>

Standard Resistance Range .....50 to 200K ohms  
 Resistance Tolerance .....±3%  
 Independent Linearity .....±0.20% Resolution  
 .....See recommended part numbers  
 Effective Electrical Angle .....3600° +10°, -0°  
 Absolute Minimum Resistance/Minimum Voltage  
 .....1 ohm or 0.1% maximum (whichever is greater)  
 Noise .....100 ohms ENR maximum  
 Power Rating (Voltage Limited By Power Dissipation or 325 VAC, Whichever Is Less)  
 +70°C .....2 watts  
 +125°C .....0 watt  
 Dielectric Withstanding Voltage MIL-STD-202, Method 301  
 Sea Level.....1,500 VAC minimum  
 70,000 Feet .....400 VAC minimum  
 Insulation Resistance (500 VDC) ....1,000 megohms minimum

### Environmental Characteristics<sup>1</sup>

Operating Temperature  
 Static Operation Temp Range .....-65°C to +125°C  
 Dynamic Temp Range .....+1°C to +125°C  
 Temperature Coefficient<sup>2</sup> .....±50ppm/°C maximum/unit  
 Vibration .....20G  
 Wiper Bounce .....0.1 millisecond maximum  
 Total Resistance Shift ...±2% maximum  
 Voltage Ratio Shift .....±0.1% maximum  
 Shock .....100G  
 Wiper Bounce .....0.1 millisecond maximum  
 Total Resistance Shift ...±2% maximum  
 Voltage Ratio Shift .....±0.1% maximum  
 Load Life .....1,000 hours, 2 watts  
 Total Resistance Shift ...±2% maximum  
 Rotational Life (No Load) .....2,000,000 shaft revolutions<sup>2</sup>  
 Total Resistance Shift ...±5% maximum  
 Moisture Resistance .....MIL-STD-202, Method 103, Condition B  
 Total Resistance Shift ...±2% maximum

### Mechanical Characteristics<sup>1</sup>

Mechanical Angle .....3600° +10°, -0°  
 Shaft Runout .....0.002 in. (0.05mm) T.I.R.  
 Lateral Runout .....0.005 in. (0.13mm) T.I.R.  
 Pilot Diameter Runout .....0.002 in. (0.05mm) T.I.R.  
 Shaft End Play .....0.005 in. (0.13mm) T.I.R.  
 Shaft Radial Play .....0.003 in. (0.08mm) T.I.R.  
 Stop Strength .....96 oz.-in. (67.8 Ncm) min.  
 Torque (Starting & Running) .....0.6 oz.-in. (0.42 Ncm) max.  
 Backlash .....1.0° maximum  
 Weight .....Approximately 28G  
 Terminals .....Gold-plated solder lugs  
 Ganging .....2 cups maximum

### Recommended Part Numbers

Part Number	Resistance	Resolution
<b>3500S-2-102</b>	<b>1,000</b>	<b>.030</b>
<b>3500S-2-502</b>	<b>5,000</b>	<b>.018</b>
<b>3500S-2-103</b>	<b>10,000</b>	<b>.019</b>

BOLD-FACE LISTINGS ARE IN STOCK AND READILY AVAILABLE THROUGH DISTRIBUTION.  
 FOR OTHER OPTIONS CONSULT FACTORY.

### 3500S-2/3501H-1

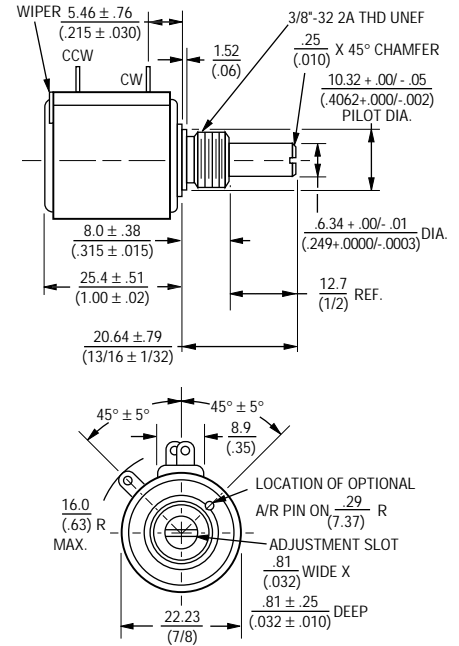

NOTE: LOCKWASHER AND HEX NUT TO BE SUPPLIED WITH EACH UNIT.

NOTE: SHAFT LENGTH VARIATIONS

3500S-1-RC	11/16 (17.46)
3500S-2-RC	13/16 (20.64)
3501H-1-RC	13/16 (20.64)

TOLERANCES: EXCEPT WHERE NOTED  
 DECIMALS: .XX ± .25  
 (.010), .XXX ± .13  
 (.005)  
 FRACTIONS: ±1/64  
 DIMENSIONS: MM  
 (IN.)

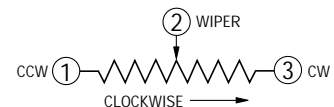

<sup>1</sup>At room ambient: +25°C nominal and 50% relative humidity nominal, except as noted.  
<sup>2</sup>Consult manufacturer for complete specification details for resistances below 500 ohms.



## Features

- Bushing mount
- Sealable
- Non-standard features and specifications available
- Optional high torque feature
- Optional center tap feature
- Gangable

# 3500/3501 - Precision Potentiometer

### Electrical Characteristics<sup>1</sup> 3500 Wirewound Element 3501 Hybritron® Element

Standard Resistance Range	50 to 200 K ohms	1 K to 200 K ohms
Total Resistance Tolerance	±3 %	±10 %
Independent Linearity	±0.20 %	±0.25 %
Effective Electrical Angle	3600° +10°, -0°	3600° +10°, -2°
Absolute Minimum Resistance/ Minimum Voltage	1 ohm or 0.1 % maximum (whichever is greater)	0.2 % maximum
Noise	100 ohms ENR maximum	Output smoothness 0.1 % max.
Dielectric Withstanding Voltage (MIL-STD-202, Method 301)		
Sea Level	1,500 VAC minimum	1,500 VAC minimum
70,000 Feet	400 VAC minimum	400 VAC minimum
Power Rating (Voltage Limited By Power Dissipation or 325 VAC, Whichever Is Less)		
+70 °C	2 watts	2 watts
+125 °C	0 watt	0 watt
Insulation Resistance (500 VDC)	1,000 megohms minimum	1,000 megohms minimum
Resolution	See recommended part nos	Essentially infinite

### Environmental Characteristics<sup>1</sup>

Operating Temperature Range	+1 °C to +125 °C	+1 °C to +125 °C
Storage Temperature Range	-65 °C to +125 °C	-65 °C to +125 °C
Temperature Coefficient Over Storage Temperature Range <sup>2</sup>	±50 ppm/°C maximum/unit	±100 ppm/°C maximum/unit
Vibration	20 G	20 G
Wiper Bounce	0.1 millisecond maximum	0.1 millisecond maximum
Total Resistance Shift	±2 % maximum	±2 % maximum
Voltage Ratio Shift	±0.1 % maximum	±0.1 % maximum
Shock	100 G	100 G
Wiper Bounce	0.1 millisecond maximum	0.1 millisecond maximum
Total Resistance Shift	±2 % maximum	±2 % maximum
Voltage Ratio Shift	±0.1 % maximum	±0.1 % maximum
Load Life	1,000 hours, 2 watts	1,000 hours, 2 watts
Total Resistance Shift	±2 % maximum	±5 % maximum
Rotational Life (No Load)	2,000,000 shaft revolutions <sup>2</sup>	4,000,000 shaft revolutions
Total Resistance Shift	±5 % maximum	±5 % maximum
Moisture Resistance (MIL-STD-202, Method 103, Condition B)		
Total Resistance Shift	±2 % maximum	±5 % maximum
IP Rating	IP 65	IP 65

### Mechanical Characteristics<sup>1</sup>

Stop Strength	67.8 N-cm (96 oz.-in.) minimum
Mechanical Angle	3600° +10°, -0°
Torque (Starting & Running)	0.42 N-cm (0.6 oz.-in.) maximum
Mounting	170-200 N-cm (15-18 lb.-in.) maximum
Shaft Runout	0.05 mm (0.002 in.) T.I.R.
Lateral Runout	0.13 mm (0.005 in.) T.I.R.
Shaft End Play	0.13 mm (0.005 in.) T.I.R.
Shaft Radial Play	0.08 mm (0.003 in.) T.I.R.
Pilot Diameter Runout	0.05 mm (0.002 in.) T.I.R.
Backlash	1.0° maximum
Weight	Approximately 28 gm
Terminals	Gold-plated solder lugs
Soldering Condition	Recommended hand soldering using Sn95/Ag5 no clean solder, 0.025" wire diameter. Maximum temperature 399 °C (750 °F) for 3 seconds. No wash process to be used with no clean flux.
Marking	Manufacturer's name and part number, resistance value and tolerance, linearity tolerance, wiring diagram, and date code.
Ganging (Multiple Section Potentiometers)	2 cups maximum
Hardware	One lockwasher (H-37-2) and one mounting nut (H-38-2) is shipped with each potentiometer.

### Recommended Part Numbers

Part Number	Resistance (Ω)	Resolution
3500S-1-102	1,000	.030
3500S-1-502	5,000	.018
3500S-1-103	10,000	.019
<b>3500S-2-102</b>	<b>1,000</b>	<b>.030</b>
<b>3500S-2-502</b>	<b>5,000</b>	<b>.018</b>
<b>3500S-2-103</b>	<b>10,000</b>	<b>.019</b>

Part Number	Resistance (Ω)
<b>3501H-1-102</b>	<b>1,000</b>
<b>3501H-1-502</b>	<b>10,000</b>
<b>3501H-1-103</b>	<b>10,000</b>

### 3500S-2/3501H-1

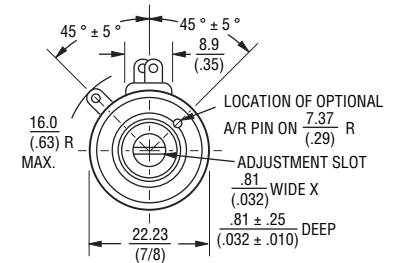
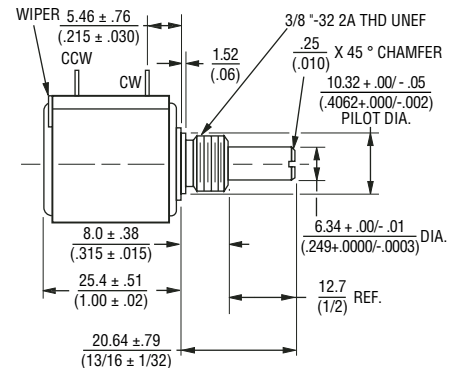

#### NOTE: SHAFT LENGTH VARIATIONS

3500S-1-RC	<b>11/16</b> (17.46)	(plastic bushing)
3500S-2-RC	<b>13/16</b> (20.64)	(metal bushing)
3501H-1-RC	<b>13/16</b> (20.64)	(metal bushing)

TOLERANCES: EXCEPT WHERE NOTED

DECIMALS: XX ± .25  
(.010), XXX ± .13  
(.005)

FRACTIONS: ±1/64

DIMENSIONS: MM  
(IN.)

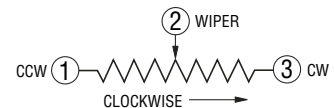

**BOLDFACE LISTINGS ARE IN STOCK AND READILY AVAILABLE THROUGH DISTRIBUTION.**

FOR OTHER OPTIONS CONSULT FACTORY.

# MATERIAL DATA SHEET



Reliable Electronic Solutions

Material #	3500S-2	
Product Line	Precision	
Posted Date	03/02/2005	
Compliance Date	Since Inception	
RoHS Compliant	Yes	

No.	Construction element	Material group	Material weight [g]	Materials	CAS If applicable	Average mass [%]	Sum [%]
1	Mandrel	Metal	2.791	Copper	7440-50-8	92-99%	11.2238%
				Organic coatings	*****	1-8%	
2	Resist Wire	Copper Alloy	0.5782	Nickel	7440-02-0	2-47%	2.3252%
				Copper	7440-50-8	Balance	
				Iron	1300-37-1	Max3%	
				Manganese	7439-96-5	Max 3%	
				Cobalt	7440-48-4	Max 0.5%	
3	Varnish	Insulating Varnish	0.1093	Phenol Resin	*****	100%	0.4395%
4	Housing Molded	Mold Compound	4.6905	Phthalate Polymer	25035-78-3	<40%	18.8626%
				Silicate	13983-17-0	<15%	
				Glass Fiber	65997-17-3	<40%	
				Alumna	27645-51-2	<10%	
				Calcium Separate	1592-23-0	<2%	
				Pentabromophenyl ether	1163-19-5	<4%	
5	Tab	Silver Solder on Nickel	0.008	Antimony Trioxide	1309-64-4	<3%	0.0322%
				Cadmium	7440-43-9	0-20%	
				Copper	7440-50-8	0-20%	
				Nickel	7440-02-0	60-80%	
				Silver	7440-22-4	0-20%	
6	Terminals	Plating	0.035	Zinc	7440-66-6	0-20%	0.1408%
				Gold	7440-57-5	>90.00%	
		Leaded Brass		Copper	7440-50-8	55-72%	
				Lead	7439-92-1	0-3.5%	





Reliable Electronic Solutions

				Tin	7440-31-5	0-1%						
				Zinc	7440-66-6	35-45%						
7	Hex Nut	Brass Alloy	1.179	Copper	7440-50-8	55.5-86%	4.7413%					
				Zinc	7440-66-6	13.90-42.5%						
				Lead	7439-92-1	.00-3.7%						
				Tin	7440-31-5	.00-1.2%						
				Aluminum	7429-90-5	.00-2.3%						
				Manganese	7439-96-5	.00-3.5%						
				Silicon	7440-21-3	.00-1.5%						
				Nickel	7440-02-0	.00-.02%						
									Carbon	7440-11-0	0.51%	
8	Lock Washer	Steel Alloy	0.2945	Manganese	7439-98-5	0.75%	1.1843%					
				Phosphorus	7723-14-0	0.02%						
				Sulfur	7704-39-9	0.025%						
				Iron	7439-89-6	98.695%						
				Chromium	7440-47-3	0.1%						
				Zinc Plating	0.00297	Tin	7440-31-5	0.64%	0.0120%			
						Zinc	7440-66-6	99.25%				
						Iron	7493-89-6	52-78%				
		9	Washer	Steel Alloy	0.008	Chromium	7440-47-3	12-24%	0.0322%			
Nickel	7440-02-0					6.0-19%						
Molybdenum	7439-98-7					0-5.0%						
Silicon	7440-21-3					0-6%						
Manganese	7439-96-3					0-2.0%						
Tungsten	7440-33-7					0-1.8%						
Aluminum	7429-90-5					0-1.5%						
Columbium	7440-03-1					0-1.0%						
Titanium	7440-32-6					0-0.7%						
Copper	7440-50-8					0.075%						
Cobalt	7440-48-4					0.1.0%						
10	Teflon Washer					PTFE	0.0082	Polytetrafluoroethylene		9002-84-0	15%	0.0330%
								1-Dichloro-1-Fluoroethane		1717-00-6	85%	
11	Ink	Ink	0.003	Formaldehyde	50-00-0	0.1-1 %	0.0121%					
				Phenol	108-95-2	1-5%						



Reliable Electronic Solutions

				Diethyl glycol monobutyl ether	112-35-6	10-30%	
12	C-Ring	Stainless Steel Alloy	0.009	Iron	7439-89-6	48-89%	0.0362%
				Chromium	7440-47-3	10-27%	
				Nickel	7440-02-0	0-22%	
				Manganese	7439-96-5	0-15%	
				Tungsten	7440-33-7	0-4%	
				Molybdenum	7439-98-7	0-4%	
				Aluminum	7429-90-5	0-2%	
				Copper	7440-50-8	0-4%	
				Silicon	7440-51-3	0-5%	
				Cobalt	7440-48-4	0-5%	
13	Lid Molded	PBT	1.962	Glass	65997-17-3	10-30%	7.8901%
				PBT	*****	65-89%	
				Antimony Oxide	1309-64-4	1-5%	
14	Bushing	Aluminum Bar	1.157	Iron	7439-89-6	86.5-99.5%	4.6528%
				Aluminum	7429-90-5	0.1-0.5%	
				Bismuth	7440-69-9	0.2-0.5%	
				Boron	7440-42-8	.01-1.0%	
				Carbon	7440-44-0	.10-1.5%	
				Chromium	7440-47-3	.4-10%	
				Columbium	7440-03-1	.15-.35%	
				Copper	7440-50-8	.30-1.90%	
				Lead	7439-92-1	.01-.15%	
				Manganese	7439-96-3	.04-0.7%	
				Molybdenum	7439-98-7	15-1.10%	
				Nickel	7440-02-0	.01-10%	
				Phosphorous	7723-14-0	.040-.12%	
				Silicon	7440-21-3	.15-2.00%	
				Sulfur	7704-34-9	.050-.35%	
				Vanadium	7440-62-2	.01-.15%	
				Zinc Coating	1314-13-2	2 oz/ft_ %	
Aluminum Coating	7429-90-5	.5 oz/ft_ %					
15	Rotor Molded	PBT	1.5625	Glass	65997-17-3	10-30%	6.2835%



Reliable Electronic Solutions

				PBT	*****	65-89%	
				Antimony Oxide	1309-64-4	1-5%	
16	Shaft	Steel Alloy	8.743	Nickel	7440-02-0	8.90%	35.1595%
				Chromium	7440-47-3	18.30%	
				Iron	1309-37-1	Balance	
				Manganese	7439-96-5	1.80%	
				Silicon	7440-21-3	1.00%	
17	Contact Spring	Metal Alloy	0.0055	Copper	7440-50-8	0-20%	0.0221%
				Nickel	7440-02-0	0-20%	
				Palladium	7440-05-3	40-60%	
				Platinum	7440-06-4	0-20%	
				Silver	7440-22-4	20-40%	
18	Collector Bar	Copper Alloy	0.105	Copper	7440-50-8	97.6-98.2%	0.4223%
				Cobalt	7440-48-4	0.2-0.35	
				Beryllium	7440-41-7	1.6-2%	
19	Cover Molded	PBT	1.099	Glass	65997-17-3	10-30%	4.4196%
				Antimony Oxide	1309-64-4	1-5%	
				PBT	*****	65-89%	
20	Terminals	Plaiting	0.326	Gold	7440-57-5	>90.00%	1.3110%
		Leaded Brass		Copper	7440-50-8	55-72%	
				Lead	7439-92-1	0-3.5%	
				Tin	7440-31-5	0-1%	
				Zinc	7440-66-6	35-45%	
21	Slider	Nylon	0.137	Molybdenum Disulfide Concentrate	1917-33-5	<4%	0.5509%
		Total weight	24.8667				