

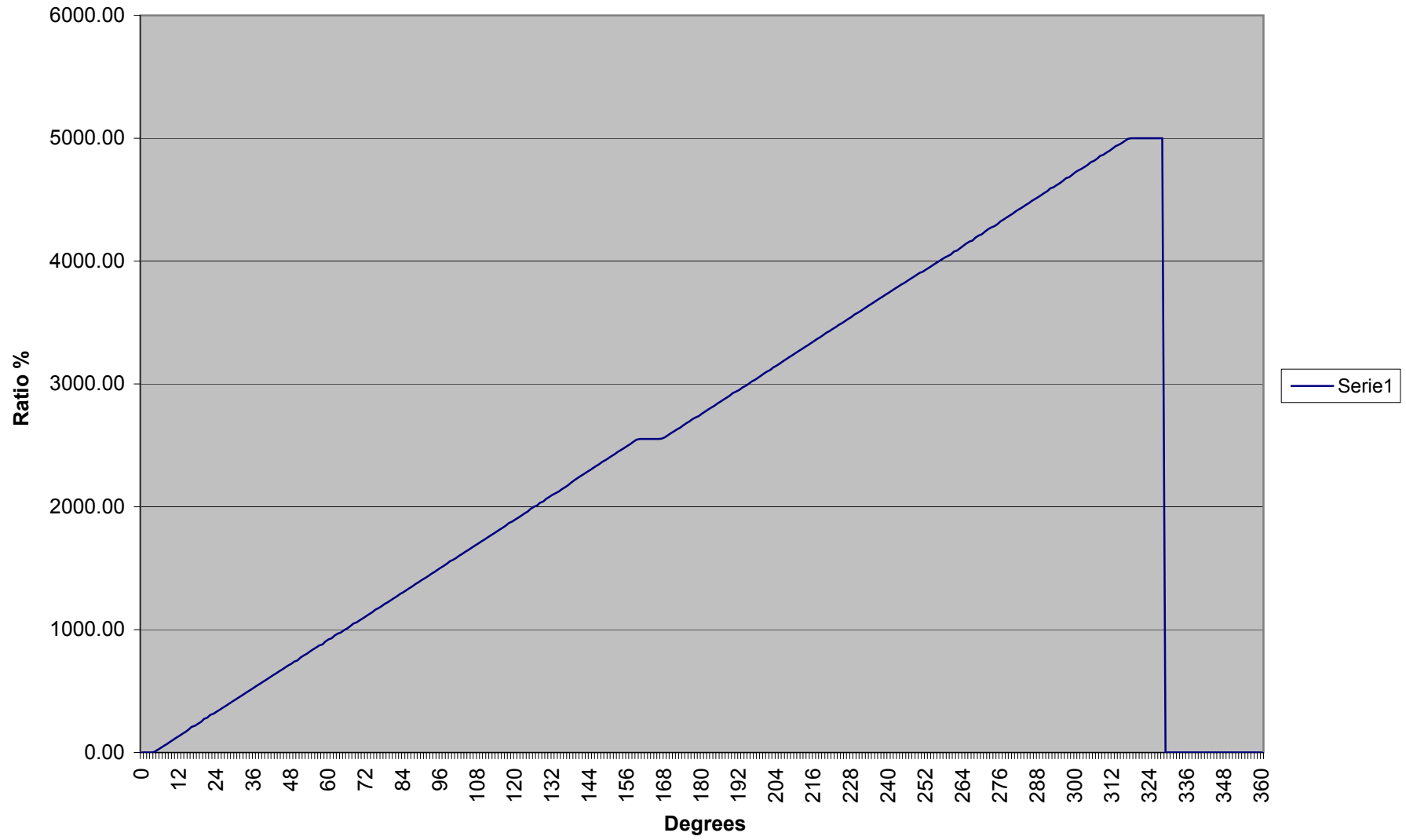

# PD210-2K5/2K5.J



Eingang-Potentiometer  
 PD 200/210  
 ø 20.0 mm  
 100.000 Zyklen  
 Draht

Singleturn Potentiometers  
 PD 200/210  
 ø 20.0 mm  
 100.000 cycles  
 Wirewound



Mechanische Daten	Mechanical Data	
Durchmesser	Diameter	20.0 mm
Achsdurchmesser	Shaft diameter	6.0 mm
Lebensdauer	Life expectancy	100.000 Zyklen/cycles
Lebensdauer	Life expectancy	10.000 Zyklen bei erhöhtem Einstell Drehmoment 10.000 cycles with higher torque
Maximales Einstell Drehmoment	Max. Torque	0.6 Ncm
Elektrische Daten	Electrical Data	
Anschlusswiderstand R	Nominal resistance R	100 Ω ... 10 K Ω
Widerstandstoleranz	Resistance tolerance	± 5 %
Linearität	Linearity	± 0,4 %
Maximaler Schleiferstrom im Störfall	Max. wiper curr. in case of malfunction	100 mA
Belastung P	Power rating P	2 W/ 40°C
Maximale Anschlussspannung	Maximum supply voltage	$U_{max} = \sqrt{P \times R}$
Maximaler Übergangswiderstand	Maximum contact resistance	ENR 100 Ω
Temperaturkoeffizient Widerstand	Temperature coefficient resistance	40 ppm/°C
Spannungsfestigkeit	Dielectric strength	1500 VAC/1 min
Isolationswiderstand	Insulating resistance	10 G Ω bei/at 500 VDC
Umgebungsbedingungen	Environmental Conditions	
Lagertemperatur	Storage temperature	-55°C... +125°C
Betriebstemperatur	Operating temperature	-55°C... +125°C
Klimatische Prüfklasse	Climatic rating	55/125/56
Schutzart	Protection rating	IP 67
Vibrationen	Vibration	10 G (30 – 2000 Hz, 0.75 mm)
Schock	Shock	50 G (Halbsinus, 7 ms) 50 G (half sine pulse, 7 ms)
Material	Material	
Gehäuse	Housing	Thermoplast
Achse	Shaft	Messing vernickelt/brass nickel plated
Anschlüsse	Connections	Messing vergoldet/brass gold plated

#### Optionen

- Achslänge bis 50 mm
- Achse mit Fläche (positioniert)
- Achsarten
- Flansch an Buchse
- Buchse mit Fläche
- Drehwinkel positioniert zu einer Fläche
- Erhöhtes Drehmoment

#### Options

- Shaft length up to 50 mm
- Flattened shaft
- Other shafts according to drawings (rimmed, notched, toothed, etc.)
- Pilot diameter
- Flattened bushing
- Index point
- Increased torque

#### Auflösungstabelle

##### Resolution chart

Widerstandswerte/Ohm Resistance values/Ohm	Auflösung/% Resolution/%
100	0.44
200	0.45
500	0.40
1K	0.32
2K	0.25
5K	0.19
10K	0.15



Typ	Model	PD 200-1A-MB	PD 202-1A-MB	PD 203-1A-MB	PD 204-1A-MB	PD 200-1B-MB	PD 202-1B-MB
Anschlussbilder	Connecting diagrams	1	1	1	1	2	2
Massbilder	Dimension drawings	A	A	A	A	B	B
Elektr. Drehwinkel	Electr. angle	318°	268°	298°	278°	318°	268°
Mech. Drehwinkel	Mech. angle	320°	270°	300°	280°	320°	270°

Anschlussbilder  
Connecting diagrams

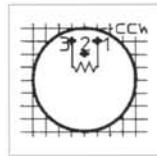

1 Raster: 2.5 mm  
Ansicht: von oben  
1 grid: 2.5 mm  
top view

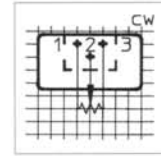

2 Raster: 2.5 mm  
Ansicht: von oben  
2 grid: 2.5 mm  
top view

Massbilder  
Dimension drawings

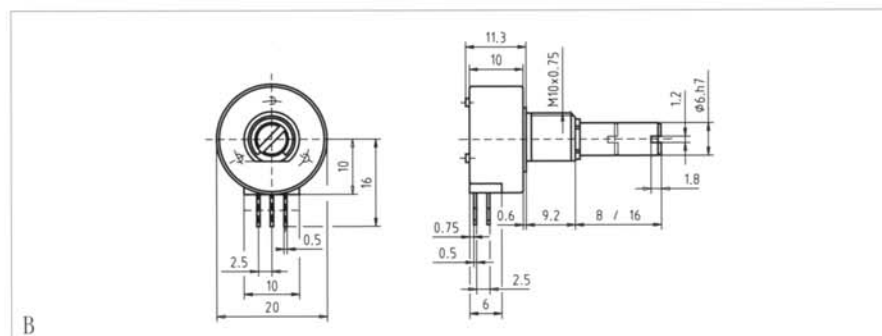
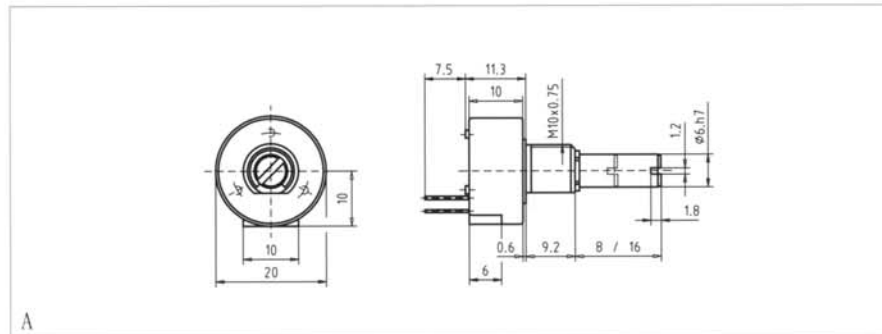

# 42

Eingang-Potentiometer  
 PD 200/210  
 ø 20.0 mm  
 100.000 Zyklen  
 Draht

Singleturn Potentiometers  
 PD 200/210  
 ø 20.0 mm  
 100.000 cycles  
 Wirewound



Typ	Model	PD 203-1B-MB	PD 204-1B-MB	PD 200-1C-MB	PD 202-1C-MB	PD 203-1C-MB	PD 204-1C-MB
Anschlussbilder	Connecting diagrams	2	2	3	3	3	3
Massbilder	Dimension drawings	B	B	C	C	C	C
Elektr. Drehwinkel	Electr. angle	298°	278°	318°	268°	298°	278°
Mech. Drehwinkel	Mech. angle	300°	280°	320°	270°	300°	280°

Anschlussbilder  
 Connecting diagrams

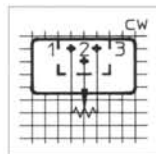

2 Raster: 2.5 mm  
 Ansicht: von oben  
 2 grid: 2.5 mm  
 top view

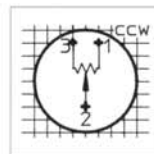

3 Raster: 2.5 mm  
 Ansicht: von oben  
 3 grid: 2.5 mm  
 top view

Massbilder  
 Dimension drawings

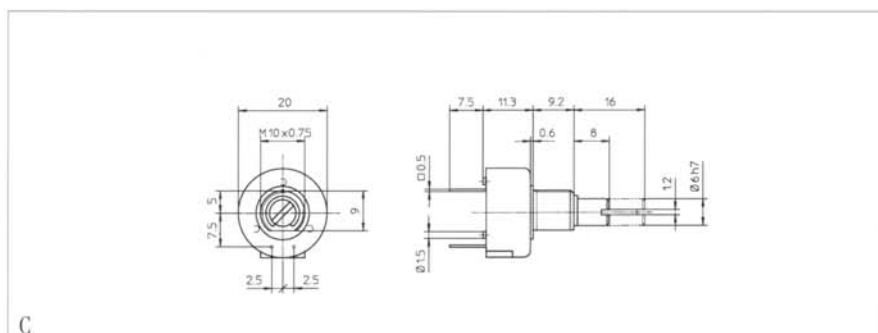
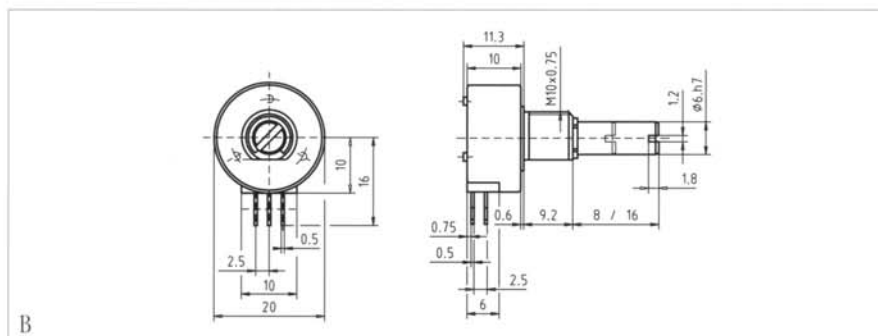



Typ	Model	PD 210-4B-MB	PD 212-4B-MB	PD 213-4B-MB	PD 214-4B-MB	PD2 210-4F-MB
Anschlussbilder	Connecting diagrams	4	4	4	4	5
Massbilder	Dimension drawings	D	D	D	D	E
Elektr. Drehwinkel	Electr. angle	318°	268°	298°	278°	318°
Mech. Drehwinkel	Mech. angle	320°	270°	300°	280°	320°

Anschlussbilder  
Connecting diagrams

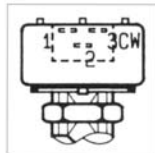

4 Raster: 2.5 mm  
Ansicht: von oben  
4 grid: 2.5 mm  
top view

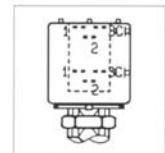

5 Raster: 2.5 mm  
Ansicht: von oben  
5 grid: 2.5 mm  
top view

Massbilder  
Dimension drawings

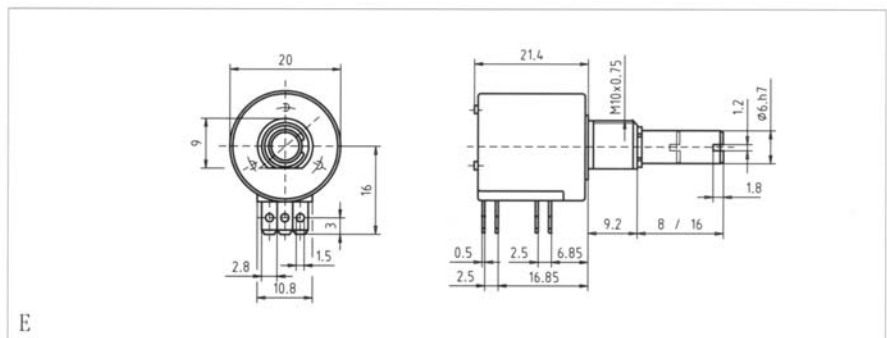
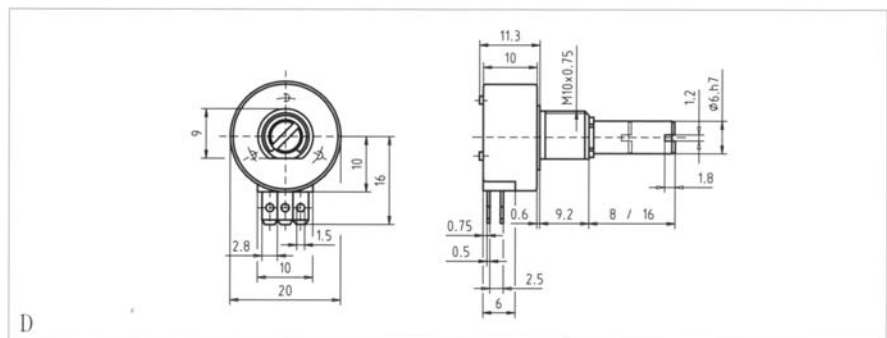

# 44

Eingang-Potentiometer  
 PD 200/210  
 ø 20.0 mm  
 100.000 Zyklen  
 Draht

Singleturn Potentiometers  
 PD 200/210  
 ø 20.0 mm  
 100.000 cycles  
 Wirewound



Typ	Model	PD 200-1B	PD 210-4B	PD 210-4B-MB	PD 212-1C-MB
Anschlussbilder	Connecting diagrams	2	4	4	3
Massbilder	Dimension drawings	G	F	D	D
Elektr. Drehwinkel	Electr. angle	318°	318°	318°	268°
Mech. Drehwinkel	Mech. angle	320°	320°	320°	270°

Anschlussbilder  
 Connecting diagrams

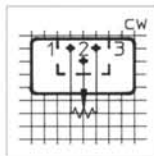

2 Raster: 2.5 mm  
 Ansicht: von oben  
 2 grid: 2.5 mm  
 top view

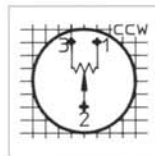

3 Raster: 2.5 mm  
 Ansicht: von oben  
 3 grid: 2.5 mm  
 top view

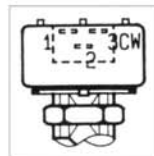

4 Raster: 2.5 mm  
 Ansicht: von oben  
 4 grid: 2.5 mm  
 top view

Massbilder  
 Dimension drawings

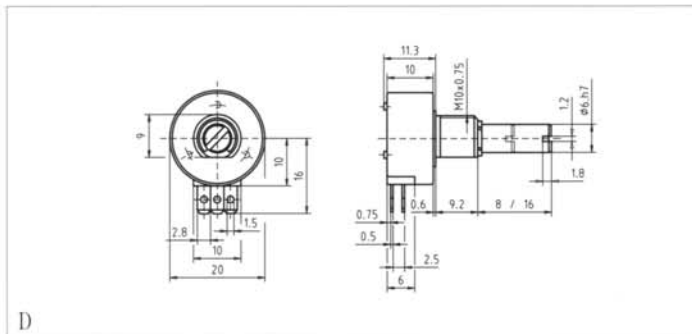

D

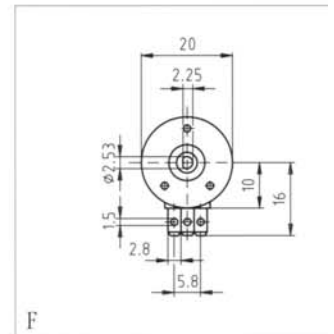

F

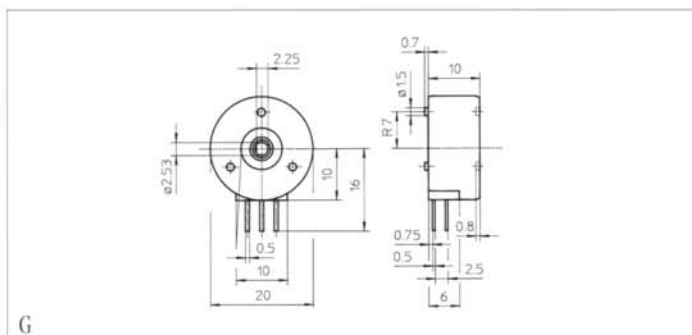

G

Typenbezeichnung/Abkürzungen  
 Marking/Remarks

Anschlussarten:	1A = Print achsial
Connections:	1A = axial PC pins
	1B = Print seitlich
	1B = side PC pins
	1C = Print achsial
	1C = axial PC pins
	4B = Steckzunge seitlich
	4B = side solder lugs
	4F = Steckzunge seitlich
	4F = side solder lugs
Gewindebuchse:	M = Metrisches Gewinde
Bushing:	M = metric thread
Achse:	B = $\varnothing$ 6 mm, mit Schlitz
Shaft:	B = $\varnothing$ 6 mm, slotted
	Z = nach Zeichnung
	Z = according to drawing

Optionen Achsen  
 Options Shaft

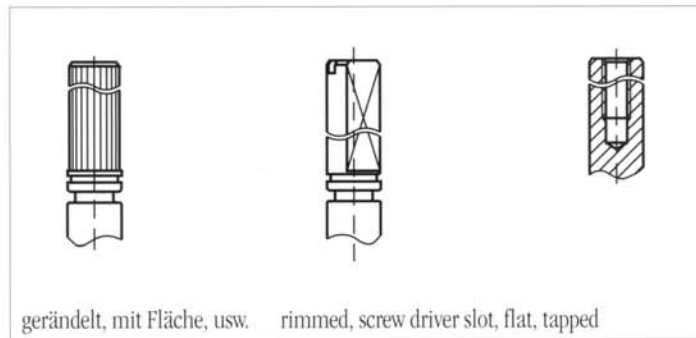

Zubehör/Massbilder  
 Accessories/Dimension

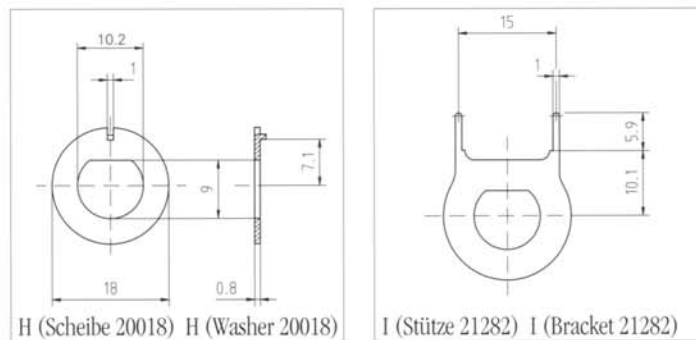

Art. Nr.	Typ	Bezeichnung	Bemerkung
Art. No.	Model	Marking	Remarks
20019	Mutter	M10 x 0.75	serienmässig
20019	Nut	M10 x 0.75	standard item
20020	Scheibe	Fächerscheibe 3/8	serienmässig
20020	Washer	Fan washer 3/8	standard item
20018	Scheibe	mit Nocken	s. Zeichnung H
20018	Washer	with cam	Drawing H
21282	Stütze	Montage horizontal	s. Zeichnung I
21282	Bracket	mounting horizontal	Drawing I

# Single-Turn Wirewound Potentiometers

## PD200 Series



### Special features

- very small dimensions
- $200 \times 10^3$  movements
- excellent linearity  $\pm 0.4\%$
- very robust
- highest protection class

Sealed potentiometer with a wirewound resistance element for control electronics and measuring applications.

Recommended for applications in harsh environments requiring a sealed potentiometer, the PD200 Series combines extraordinary-high media resistance and robust engineering.

Careful selection of materials and high-quality components ensure a constant and accurate angle measurement throughout the entire service life of the sensor.

Special designs with other angular ranges, shaft dimensions, connections and higher torque are available on request.

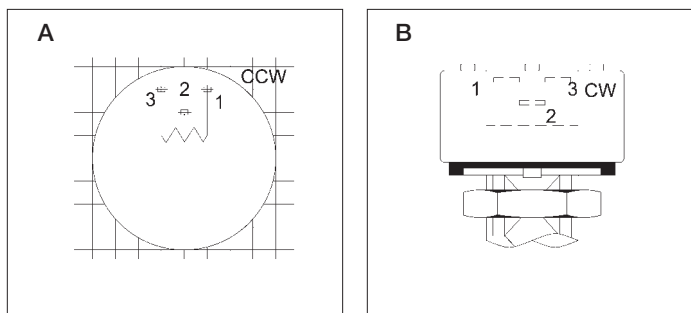
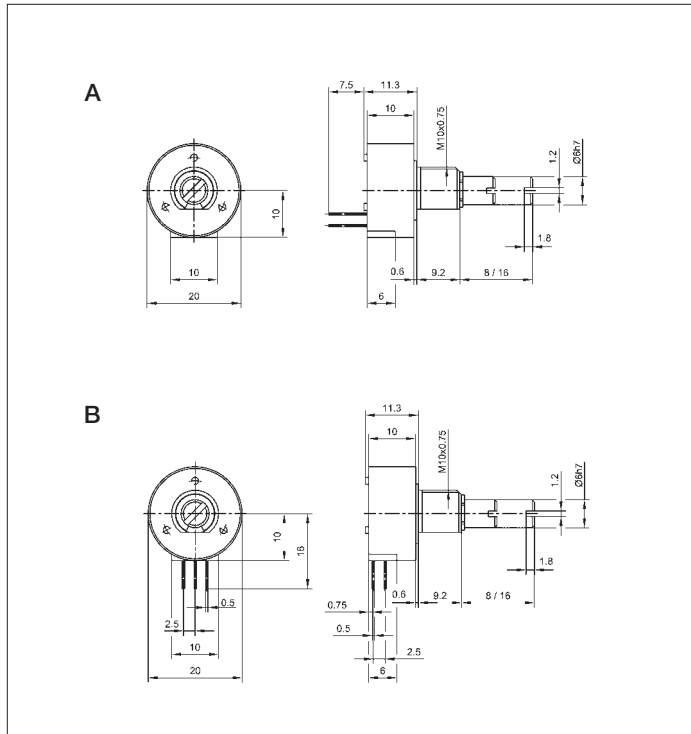

Description	
Size	housing diameter 20 mm
Housing	high-quality, temperature-consistent plastic
Shaft	brass, nickel plated
Bearings	sleeve bearings
Resistance element	wirewound
Wiper assembly	precious metal
Electrical connections	gold plated



Type designations	PD200...1A-MB	PD200...1B-MB				
<b>Mechanical Data</b>						
Dimensions	see drawing A		see drawing B			
Mounting	nut M10 x 0.75, serrated washer 3/8"					
Mechanical travel	320	°				
Permitted shaft loading (axial and radial) static or dynamic force	1	N				
Torque	≤ 0.6	Ncm				
Permitted max. torque for mech. stops	100	Ncm				
Maximum operational speed	120	RPM				
Weight	16	g				
<b>Electrical Data</b>						
Actual electrical travel	318 ±3	°				
Available resistance values	1	2	5	10	20	kΩ
Resistance tolerance	±5					%
Repeatability	0.32 (=1°)	0.25 (=0.8°)	0.19 (=0.6°)	0.15 (=0.5°)	0.11 (=0.35°)	%
Effective temperature coefficient of the output-to-applied voltage ratio	5 (typical)					ppm/K
Independent linearity	±0.4					%
Max. permissible applied voltage	42					V
Recommended operating wiper current	≤ 10					μA
Max. wiper current in case of malfunction	100					mA
Insulation resistance (500 VDC, 1 bar, 2 s)	≥ 10,000					MΩ
Dielectric strength (AC, 50 Hz, 1 min, 1 bar)	1,500					V
<b>Environmental Data</b>						
Temperature range	-55...+125					°C
Vibration	30...2000 A <sub>max</sub> = 0.75 a <sub>max</sub> = 10					Hz mm g
Life	200 x 10 <sup>3</sup>					movements
Shock (DIN IEC 68 T2-27)	50					g
	7					ms
Protection class (DIN 40050)	IP 67					

#### Order designations

Type	Art. no.	R in kΩ	Length of shaft mm
PD200I 1K0 1A160 MB	048000	1	16
PD200I 2K0 1A160 MB	048002	2	16
PD200I 5K0 1A160 MB	048004	5	16
PD200I 10K0 1A160 MB	048005	10	16
PD200I 20K0 1A160 MB	048007	20	16
PD200I 1K0 1B160 MB	048001	1	16
PD200I 2K0 1B160 MB	048003	2	16
PD200I 5K0 1B160 MB	048047	5	16
PD200I 10K0 1B160 MB	048006	10	16
PD200I 20K0 1B160 MB	048008	20	16

#### Order designations / Abbreviations

1A: connecting solder pin axial  
1B: connection solder pin radial  
MB: bushing M10 x 0.75, axis Ø 6 mm with slot

#### Included in delivery

1 nut M10 x 0.75  
1 serrated washer 3/8"

#### Recommended accessories

Fork coupling Z 104 G6, Art. no. 005690;  
Fork coupling Z 105 G6 (backlash-free), Art. no. 005691, MAP process-control indicators and display. MUP signal conditioner for standardized output signals.

#### Important

All values given for this series – including linearity, lifetime, micro-linearity, resistance to external disturbances and temperature coefficient in voltage dividing mode – are quoted for the device operating with the wiper voltage driving an operational amplifier working as a voltage follower where virtually no load is applied to the wiper ( $I_e \leq 1 \mu A$ ).

# Single-Turn Wirewound Potentiometers

## PD210 Series



### Special features

- very small dimensions
- $200 \times 10^3$  movements
- excellent linearity  $\pm 0.4\%$
- very robust
- highest protection class

Sealed potentiometer with a wire-wound resistance element for control electronics and measuring applications.

Recommended for applications in harsh environments requiring a sealed potentiometer, the PD210 Series combines extraordinarily-high media resistance and robust engineering.

Careful selection of materials and high-quality components ensure a constant and accurate angle measurement throughout the entire service life of the sensor.

Special designs with other angular ranges, shaft dimensions, connections and higher torque are available on request.

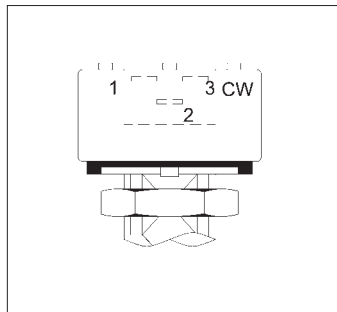
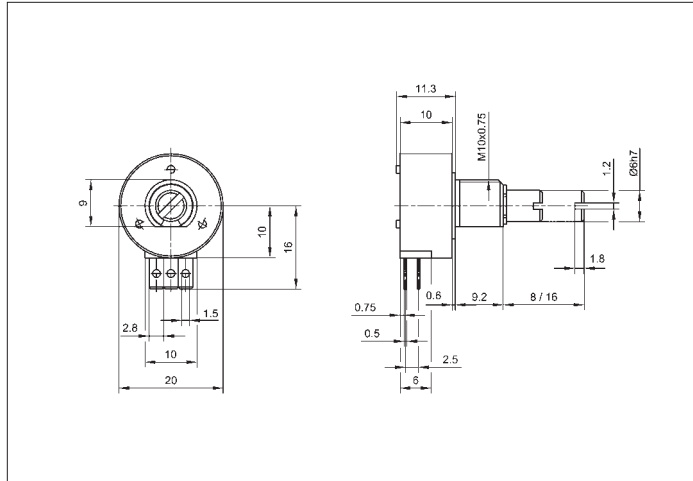

### Description

Size	housing diameter 20 mm
Housing	high-quality, temperature-consistent plastic
Shaft	brass, nickel plated
Bearings	sleeve bearings
Resistance element	wirewound
Wiper assembly	precious metal
Electrical connections	gold plated

Mechanical Data		
Dimensions	see drawing	
Mounting	nut M10 x 0.75, serrated washer 3/8"	
Mechanical travel	320	°
Permitted shaft loading (axial and radial) static or dynamic force	1	N
Torque	≤ 0.6	Ncm
Permitted max. torque for mech. stops	100	Ncm
Maximum operational speed	120	RPM
Weight	16	g

Electrical Data						
Actual electrical travel	318 ±3					°
Available resistance values	1	2	5	10	20	kΩ
Resistance tolerance	±5					%
Repeatability	0.32 (=1°)	0.25 (=0.8°)	0.19 (=0.6°)	0.15 (=0.5°)	0.11 (=0.35°)	%
Effective temperature coefficient of the output-to-applied voltage ratio	5 (typical)					ppm/K
Independent linearity	±0.4					%
Max. permissible applied voltage	42					V
Recommended operating wiper current	≤ 10					μA
Max. wiper current in case of malfunction	100					mA
Insulation resistance (500 VDC, 1 bar, 2 s)	≥ 10,000					MΩ
Dielectric strength (AC, 50 Hz, 1 min, 1 bar)	1,500					V

Environmental Data		
Temperature range	-55...+125	°C
Vibration	30...2000	Hz
	A <sub>max</sub> = 0.75	mm
	a <sub>max</sub> = 10	g
Life	200 x 10 <sup>3</sup>	movements
Shock (DIN IEC 68 T2-27)	50	g
	7	ms
Protection class (DIN 40050)	IP 67	

Order designations					
Type	Art. no.	R in kΩ	Length shaft in mm		
PD210 1K0 4B080 MB	048009	1	8		
PD210 2K0 4B080 MB	048011	2	8		
PD210 5K0 4B080 MB	048013	5	8		
PD210 10K0 4B080 MB	048015	10	8		
PD210 20K0 4B080 MB	048017	20	8		
PD210 1K0 4B160 MB	048010	1	16		
PD210 2K0 4B160 MB	048012	2	16		
PD210 5K0 4B160 MB	048014	5	16		
PD210 10K0 4B160 MB	048016	10	16		
PD210 20K0 4B160 MB	048018	20	16		

### Order designations / Abbreviations

4B: connecting pin, radial  
MB: bushing M10 x 0.75, axis Ø 6 mm with slot

### Included in delivery

1 nut M10 x 0.75  
1 serrated washer 3/8"

### Recommended accessories

Fork coupling Z 104 G6, Art. no. 005690;  
Fork coupling Z 105 G6 (backlash-free), Art. no. 005691, MAP process-control indicators and display. MUP signal conditioner for standardized output signals.

### Important

All values given for this series – including linearity, lifetime, micro-linearity, resistance to external disturbances and temperature coefficient in voltage dividing mode – are quoted for the device operating with the wiper voltage driving an operational amplifier working as a voltage follower where virtually no load is applied to the wiper ( $I_e \leq 1 \mu A$ ).