

New

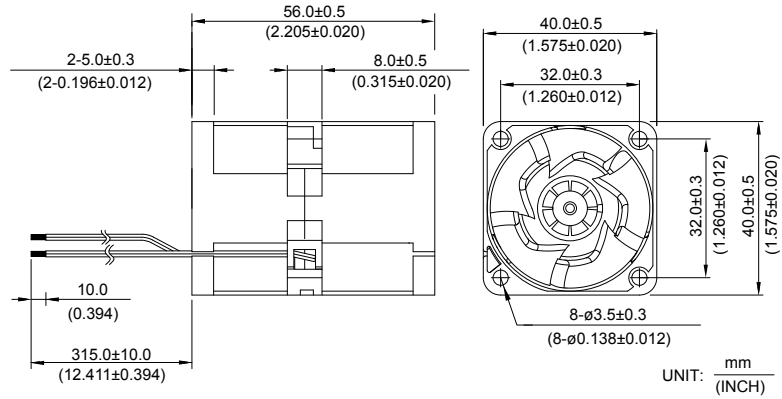

GFB 40 x 40 x 56 MM SERIES

■ DIMENSIONS DRAWING



- * Bearing Type
Ball Bearings
- * Material
Impeller & Pillow : Plastic (UL 94V-0)
- * Lead Wires :
UL 1061 AWG #26 OR Equivalent
Red And Orange Wire Positive(+)
Black And Brown Wire Negative(-)
- * Weight : 83g (2.93 oz)

■ P & Q CURVE (AT RATED VOLTAGE)

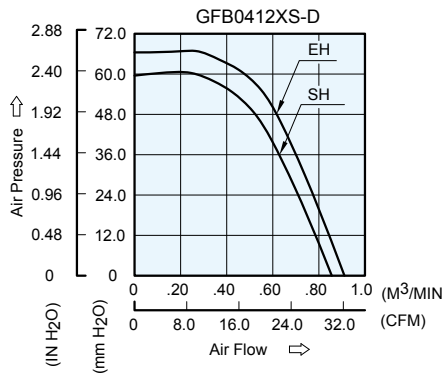

■ MOUNTING PANEL CUTOUT

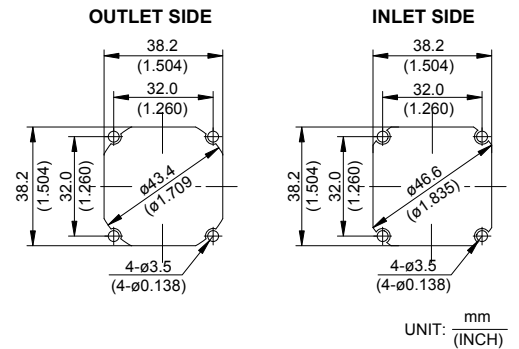

MODEL			Rated Voltage	Operating Voltage Range	Input Current	Input Power	Speed (Front/Rear)	Maximum Air Flow		Maximum Air Pressure		Noise
PART NO.	REV.	FUNCTION	VDC	VDC	Amp	Watt	R.P.M.	m ³ /min	CFM	mmH ₂ O	IN H ₂ O	dB-A
GFB0412SHS	-D	-R00/-F00	12	10.8 to 12.6	1.10	13.20	15000/14300	0.856	30.23	59.55	2.344	63.0
GFB0412EHS	-C	-R00/-F00	12	10.8 to 12.6	1.30	15.60	16000/15400	0.911	32.18	66.82	2.631	64.5

* Function type is optional.
 * The max. air flow and the speed are measured in free air ; max. air pressure is measured at zero air flow.
 * Noise is measured in anechoic chamber in free air, one meter from intake side.
 * All readings are typical values at rated voltage.
 * Specifications are subject to change without notice.