

CXA-L0624-VJL/CXA-L0624-VSL

Dimming/Connector Type

■ Features

- 1 output
- Applicable panel size*: 3 to 15 inches
- With brightness control function (Current dimming).
- In the high-voltage generator (a terminal and a pattern), an anti-dust measure by silicone application is taken.
(Notice) Applicable panel size becomes a standard.

■ Applications



DC-AC Inverter

CXA-L0624-VJL / CXA-L0624-VSL Specifications (Please refer to each specification before use)

Electrical Characteristics

Item	Unit	Symbol	Specification			Condition					Remarks
			min	typ	max	Vin(V)	Vrmt(V)	Vbr(V)	Ta(°C)	RL(kΩ)	
Output Current	mArms	Iout (Maximum dimmer)	5.4	6	6.6	24±4	5	0	0 to +60	90 to 110	(*1)
		Iout (Minimum dimmer)	2.7	3	3.3	24±4	5	3	23±5	226	(*1)
Input Current	A	Iin	-	0.2	0.25	24	5	0	0 to +60	90 to 110	Remote ON
Oscillatory Frequency	kHz	Freq	35	45	55	24±4	5	0	0 to +60	90 to 110	
Open Circuit Voltage	Vrms	Vopen	1400	1500	-	24±4	5	0	0 to +60	∞	Open load

(*1) Please refer to the connection diagram for details of a dimming method.

Other Specifications

Dimming Function		Yes
Operating Temperature	°C	0 to +60
Storage Temperature	°C	-30 to +85
Operating Humidity Ratio	RH%	95max.
Safety Standard		—
Weight	g	13.7typ.
Dimensions (WxDxH)	mm	95.5x20x8.0 (*2)
Fused Input		Yes
Remote ON / OFF		Yes
Alarm Signal Function		No
Shutdown Function		No
Silicone Coating on High Voltage Area		Yes

(*2) These dimensions are indicated the maximum.

■ Conformity to RoHs Directive

This means that, in conformity with EU Directive 2002/95/EC, lead, cadmium, mercury, hexavalent chromium, and specific bromine-based flame retardants, PBB and PBDE, have not been used, except for exempted applications.

Connector type/1 output

Outline Drawing

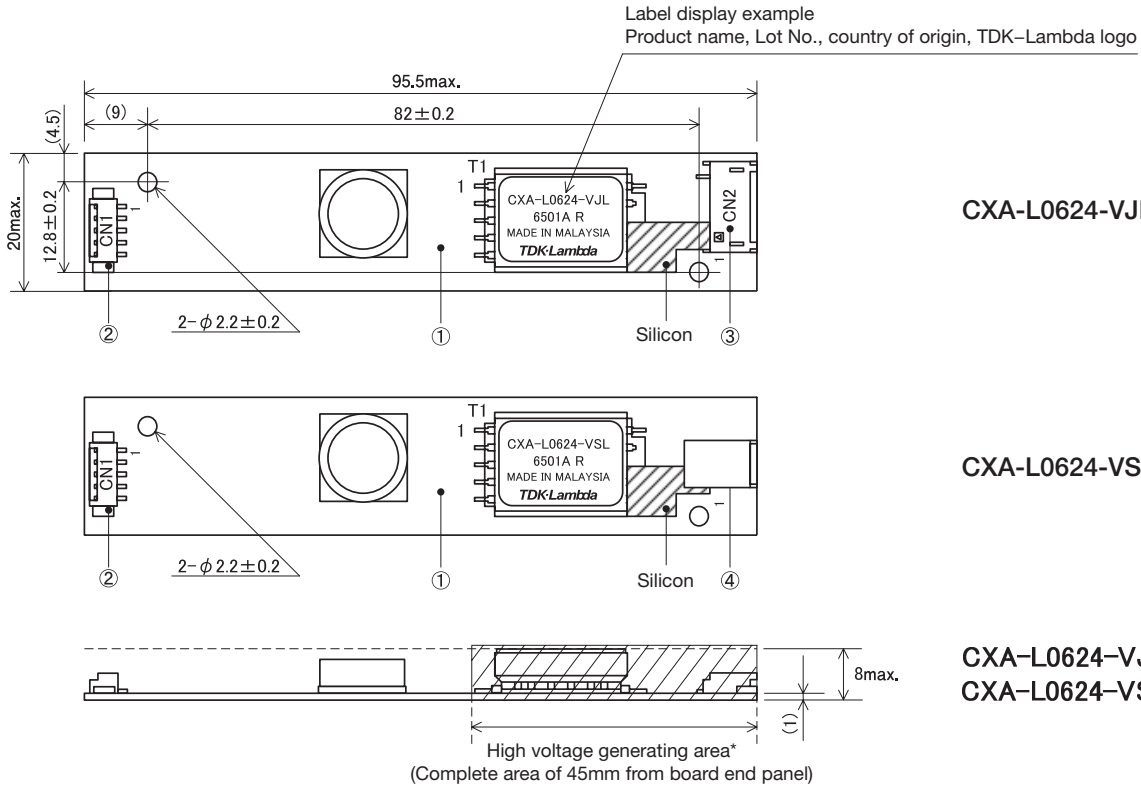

CXA-L0624-VJL

CXA-L0624-VSL

CXA-L0624-VJL
CXA-L0624-VSL

Unit: mm

*From high-voltage generator, please secure space distance more than 3mm in top and bottom right and left.

Connector

No.	Component name	Type name	Qty	Manufacturer	Recommended suitable connector	Remarks
①	Printed circuit board PCB	Composite (CEM-3)	1	-	-	UL94V-0 t=1.0
②	Input connector CN1	53261-0571	1	Molex	51021-0500	-
③	Output connector CN2	SM02(8.0)B-BHS-1-TB(LF)(SN)	1	J.S.T Mfg., Co., Ltd	BHR-03VS-1	CXA-L0624-VJL
④	Output connector CN2	SM02B-BHSS-1-TB(LF)(SN)	1	J.S.T Mfg., Co., Ltd	BHSR-02VS-1	CXA-L0624-VSL

Terminal Number & Function

Input side CN1

Terminal No.	Symbol	Rating	Remarks
CN1-1	Vin	24±4V	Power source input
CN1-2	GND	0V	Ground
CN1-3	Vrmt	0V/2.5V to Vin	Remote terminal 0 to 0.4V : OFF 2.5V to Vin : ON
CN1-4	Vbr	0 to 3V	Dimmer terminal
CN1-5	N.C.	-	Because it uses for internal circuit, please be not connected.

Output side CN2 (CXA-L0624-VJL)

Terminal No.	Symbol	Rating
CN2-1	V _{HIGH}	Output
CN2-2	N.C.	-
CN2-3	V _{LOW}	Output return

Output side CN2 (CXA-L0624-VSL)

Terminal No.	Symbol	Rating
CN2-1	V _{HIGH}	Output
CN2-2	V _{LOW}	Output return

Connections

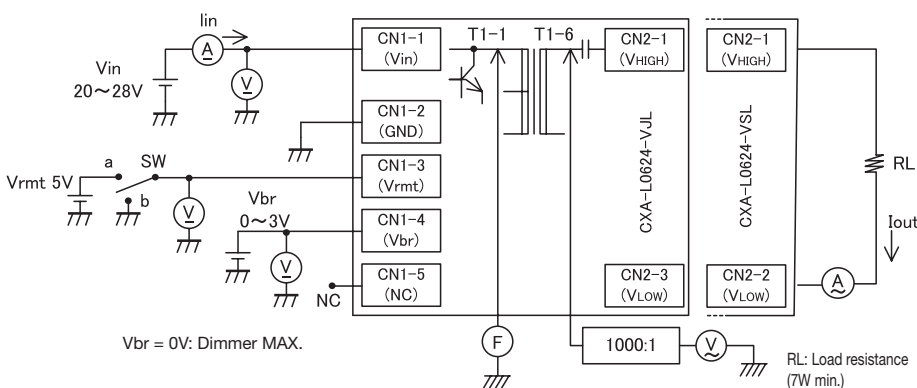

Operate as follows by switching a SW.

SW	Unit operates
a	Operates
b	Does not operate
Open	