



# BM6015 ( $\phi 60 \times 15^L$ )



EMINEBEA.COM

## General Specifications

### Allowable Ambient Temperature Range:

- 10°C ~ +70°C (Operating)
- 40°C ~ +70°C (Storage)
- (non-condensing environment)

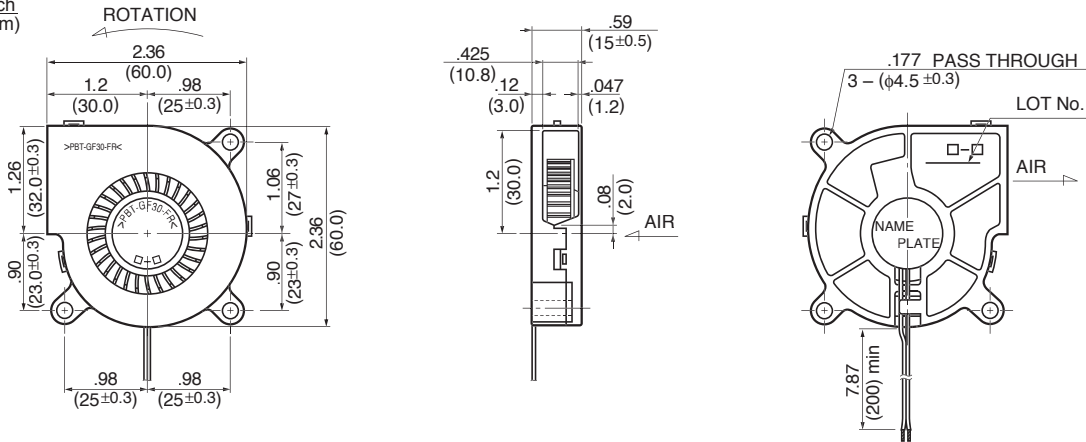
## Expected Life

### Failure Rate: 10%

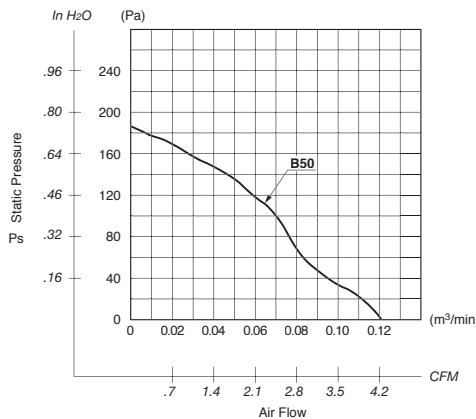
- 25°C 50,000 Hours (L00)
- 25°C 40,000 Hours (T00)

## Outline

Units:  $\frac{\text{inch}}{\text{mm}}$



## Characteristic Curves



## Material

- Casing : Plastic (Black) 94V-0
- Impeller : Plastic (Black) 94V-0
- Bearing : Ball Bearing
- Lead Wire : UL1007, AWG26, +Red, -Black

## Specifications

MODEL	Product No.	Rated Voltage	Operating Voltage	Current	Input Power	Speed	Max. Air Flow		Max. Static Pressure		Noise	Mass
		(V)	(V)	(A) <sup>*1</sup>	(W) <sup>*1</sup>	(min <sup>-1</sup> ) <sup>*1</sup>	CFM <sup>*1</sup>	(m <sup>3</sup> /min) <sup>*1</sup>	in H <sub>2</sub> O	(Pa) <sup>*1</sup>	(dB) <sup>*1</sup>	(g)
BM6015-04W-B50-	L00	12	9 ~ 12.6	0.22	2.64	5600	4.2	0.12	.68	168.9	42.0	30

Rotation: Counterclockwise

\*1: Average Values in Free Air



English  
日本語

Product Catalog Engineering Info Company Links Contact Us

Fan Motors  
Engineering  
Information

DC Fans

- 1.Common Spec.
- 2.Numbering (Axial Fans)
- 3.Numbering (FB)
- 4.Numbering (Blowers BM)
- 5.Numbering (Blowers BG)
- 6.Numbering (FAL)
- 7.Sensors
- 8.Speed Control

AC Fans

- Technical Information
- Handling Precautions
- Quality & Environment

DC Blowers BM Series Part Numbering System

To show details, place the mouse cursor on each item of the part number. Click "Display All" button to show all details.

**BM 51 15 - 04 W - B 3 0 - L 00** [Display All](#)  
 (1) (2) (3) (4) (5) (6) (7) (8) (9) (10)

<b>1. Series</b>	<b>2. Size</b>	<b>3. Thickness</b>	<b>4. Input Voltage</b>	<b>5. Termination</b>
BM Series	45 45mm 51 51mm 60 60mm	15 15mm 25 25mm	01 5V 04 12V 05 24V 09 Custom Voltage	Lead Wires
<b>6. Bearing</b>	<b>7. Speed</b>	<b>9. Classification</b>	<b>10. Individual Specification</b>	
B Ball Bearing S Sleeve Bearing	1 < 2 < 3 < 4 < 5 low high	L Standard Model T Value Model	Standard Type 00 Standard 01-99 Custom	Sensor Type 00 Locked Rotor Alarm Signal (Standard Type) 01-49 Locked Rotor Alarm Signal (Custom Type) 50 Tachometer Signal (Standard Type) 51-99 Tachometer Signal (Custom Type)
<b>8. Special Control Function</b>				
0 Standard type 9 Sensor type 8 2-speed type	7 Temperature detecting variable speed type/sensor type 6 Temperature detecting variable speed type/sensor type 5 2-speed type/sensor type			

# Fans

DC Axial • DC Blowers • AC Axial



  
**NMB**<sup>TM</sup>  
*Minebea*

# ***NMB Technologies Corporation***



**NMB Technologies Corporation** is a subsidiary of NMB (USA) Inc., the North American headquarters and operating center of the Minebea Group of Companies. Minebea Co., Ltd., was established in 1951 as Japan's first specialized manufacturer of miniature ball bearings.

Today, the Company is the world's leading comprehensive manufacturer of miniature ball bearings and high precision components, supplying customers worldwide in the information and telecommunications equipment industry, as well as the aerospace, automotive and household electrical appliance industries.

The Minebea Group consists of 43 subsidiaries and affiliates in 16 countries, including Japan, Thailand, China and Singapore as well as several others in Europe and the Americas. The Group maintains 30 plants and 37 sales offices, and employs approximately 55,000 people worldwide.

NMB offers a comprehensive line of more than 100 axial fans ranging in size from 25mm to 173mm. DC and AC axial fans and blowers are designed to solve thermal management problems for our OEM customers. Producing over 100 million fans per year, NMB's focus is on total thermal management solutions.

NMB Technologies Corporation's domestic headquarters are located in Chatsworth, California. Highly trained application engineers, experienced product managers and customer service representatives work closely with customers to develop the most cost effective solutions for today's challenging applications. Pre-design and after-delivery follow-up assure complete customer satisfaction.

Contact NMB Technologies Corporation today. Visit our web site at [www.nmbtc.com](http://www.nmbtc.com) or call our Fan Product Group directly at 818-341-3355.



## DC Axial Fans

Common Specifications and Part Numbering System.....	1.1
Common Specifications and Part Numbering System - Turbo Fans.....	1.2
1604KL.....	1.3
1608VL.....	1.4
1619FT..... <b>NEW!</b>	1.5
2410SB.....	1.5
3110SB.....	1.7
3610SB.....	1.8
3610VL.....	1.9
4715KL.....	1.10
4715KL 3 Blade.....	1.11
4715VL.....	1.12
5920VL.....	1.13

## DC Blowers

Common Specifications and Part Numbering System.....	2.1
BM5020.....	2.2
BG0703.....	2.3
BG0903.....	2.4
BG1203.....	2.5
Notes.....	2.6

## AC Axial Fans

Common Specifications and Part Numbering System.....	3.1
2412PS.....	3.2
3110MS..... <b>NEW!</b>	3.3
3110PS.....	3.4
3115FS.....	3.5
3115PS.....	3.6-3.7
3610PS.....	3.8-3.9
4710PS.....	3.10-3.11
4715FS.....	3.12
4715HS Plastic Blades/Standard..... <b>NEW!</b>	3.13
4715HS Plastic Blades/Potting..... <b>NEW!</b>	3.14
4715MS.....	3.15-3.16
4715TS Metal Blades/Standard..... <b>NEW!</b>	3.17
4715TS Metal Blades/Potting..... <b>NEW!</b>	3.18
5915PC Plastic Blades/Standard.....	3.19-3.20
5915PC Plastic Blades/Potting..... <b>NEW!</b>	3.21
5915PC Metal Blades/Standard.....	3.22
5915PC Metal Blades/Potting..... <b>NEW!</b>	3.23

<b>Agency Approvals</b> .....	4.1-4.2
-------------------------------	---------

<b>Fan Engineering</b> .....	5.1-5.8
------------------------------	---------

<b>Accessories - Fan Guards</b> .....	6.1
---------------------------------------	-----

<b>Fan Accessories Matrix (Guards/Mounting Clips/Cord Sets)</b> .....	6.2
---	-----

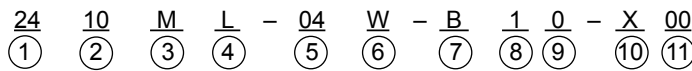
<b>Warranty</b> .....	6.3
-----------------------	-----

## Common Specifications

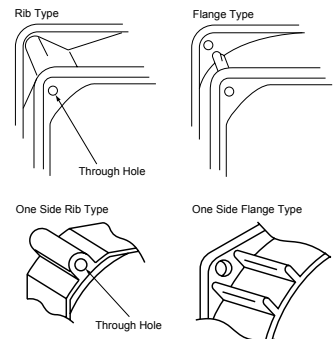
- Vibration Test:..... Conforms to JIS C 60068-2-6, Amplitude: 1.5mm, Frequency 10 to 55 Hz, 1 hour in each of the X, Y and Z directions.
- Shock Test: ..... Conforms to JIS C 60068-2-27, Acceleration rate: 981 m/s2\*, Application time: 6ms once each in the X, Y and Z directions. Note: For the 1604KL, 1608KL, and 2406KL series, the conditions of the shock test are as follows: Acceleration rate: 500 m/s2, Application time: 11ms once each in the X, Y and Z directions.
- Locked Rotor Protection : .. The motor is protected from burnout in the locked rotor condition for 72 hours at the rated voltage.
- Polarity Protection : ..... The fans are Reverse Polarity protected at the rated voltage.
- Insulation Class : ..... E class (UL: Class A)
- Auto Restart:..... Most fan models provide current shut-down/auto restart function under locked rotor conditions.

*Notes:* Additional performance requirements can be determined between manufacturer and customer, based on customer's request.  
Ball bearing fans may be installed in a horizontal, vertical or angled position

## Part Numbering System



- |  |  |   |      |                |                |    |                |          |    |                |             |    |                |          |    |                |             |    |                |          |    |                |             |  |
|--|--|---|------|----------------|----------------|----|----------------|----------|----|----------------|-------------|----|----------------|----------|----|----------------|-------------|----|----------------|----------|----|----------------|-------------|--|
| <p><b>1. Frame Size</b></p> <ul style="list-style-type: none"> <li>10:25mm</li> <li>12:30mm</li> <li>14:35mm</li> <li>16:40mm</li> <li>20:50mm</li> <li>21:52mm</li> <li>24:60mm</li> <li>28:70mm</li> <li>31:80mm</li> <li>36:92mm</li> <li>47:119mm</li> <li>50:127mm</li> <li>59:150mm</li> <li>68:172mm</li> </ul> <p><b>2. Overall Length (Thickness)</b></p> <ul style="list-style-type: none"> <li>04:10mm</li> <li>06:15mm</li> <li>08:20mm</li> <li>10:25mm</li> <li>12:32mm</li> <li>15:38mm</li> <li>20:50mm</li> </ul> | <p><b>3. Series</b></p> <ul style="list-style-type: none"> <li>P Series</li> <li>M Series</li> <li>N Series</li> <li>K Series</li> <li>H Series</li> <li>S Series</li> <li>F Series</li> <li>R Series</li> <li>V Series</li> </ul> <p><b>4. Motor Function</b></p> <ul style="list-style-type: none"> <li>Brushless Type DCM</li> </ul> <p><b>5. Input Voltage</b></p> <ul style="list-style-type: none"> <li>O: Standard Current</li> <li>C: Special Current</li> <li>D~Z: Special Current (A.B.O. are not used)</li> <li>1: 5V    5: 24V</li> <li>2: 6V    6: 36V</li> <li>3: 9V    7: 48V</li> <li>4: 12V   9: Other</li> </ul> <p><b>6. Termination</b></p> <ul style="list-style-type: none"> <li>W: Lead Wires</li> <li>T: Terminal (Terminal option on 3610KL and 4715KL Series)</li> </ul> | <p><b>7. Bearing</b></p> <ul style="list-style-type: none"> <li>B: Ball Bearing</li> <li>S: Sleeve Bearing</li> </ul> <p><b>8. Speed</b></p> <ul style="list-style-type: none"> <li>1&lt;2&lt;3&lt;4&lt;5&lt;6&lt;7&lt;8</li> <li>low                      high</li> </ul> <p><b>9. Special Control Function</b></p> <ul style="list-style-type: none"> <li>0: Standard Type</li> <li>9: Sensor Type</li> <li>7: Temperature Detecting Variable Speed Type/PWM Control Type</li> <li>6: Temperature Detecting Variable Speed Type/Sensor Type</li> <li>5: 2-Speed Type/Sensor Type</li> <li>8: 2-Speed Type</li> </ul> <p><b>10. Product Number</b></p> <table border="0"> <tr> <td>Item</td> <td>Classification</td> <td>Mounting Style</td> </tr> <tr> <td>L:</td> <td>Standard Model</td> <td>Rib Type</td> </tr> <tr> <td>P:</td> <td>Standard Model</td> <td>Flange Type</td> </tr> <tr> <td>B:</td> <td>Standard Model</td> <td>Rib Type</td> </tr> <tr> <td>E:</td> <td>Standard Model</td> <td>Flange Type</td> </tr> <tr> <td>G:</td> <td>Standard Model</td> <td>Rib Type</td> </tr> <tr> <td>D:</td> <td>Standard Model</td> <td>Flange Type</td> </tr> </table> | Item | Classification | Mounting Style | L: | Standard Model | Rib Type | P: | Standard Model | Flange Type | B: | Standard Model | Rib Type | E: | Standard Model | Flange Type | G: | Standard Model | Rib Type | D: | Standard Model | Flange Type | <p><b>11. Individual Specifications</b></p> <p><b>Standard Type</b></p> <ul style="list-style-type: none"> <li>00        Standard</li> <li>01~99:   Custom</li> </ul> <p><b>Sensor Type</b></p> <ul style="list-style-type: none"> <li>00:        Locked Rotor Alarm Signal (Standard)</li> <li>01~49:   Locked Rotor Alarm Signal (Custom)</li> <li>50:        Tachometer Signal (Standard)</li> <li>51~99:   Tachometer Signal (Custom)</li> </ul> |
| Item   | Classification   | Mounting Style  |      |                |                |    |                |          |    |                |             |    |                |          |    |                |             |    |                |          |    |                |             |  |
| L:   | Standard Model   | Rib Type  |      |                |                |    |                |          |    |                |             |    |                |          |    |                |             |    |                |          |    |                |             |  |
| P:   | Standard Model   | Flange Type   |      |                |                |    |                |          |    |                |             |    |                |          |    |                |             |    |                |          |    |                |             |  |
| B:   | Standard Model   | Rib Type  |      |                |                |    |                |          |    |                |             |    |                |          |    |                |             |    |                |          |    |                |             |  |
| E:   | Standard Model   | Flange Type   |      |                |                |    |                |          |    |                |             |    |                |          |    |                |             |    |                |          |    |                |             |  |
| G:   | Standard Model   | Rib Type  |      |                |                |    |                |          |    |                |             |    |                |          |    |                |             |    |                |          |    |                |             |  |
| D:   | Standard Model   | Flange Type   |      |                |                |    |                |          |    |                |             |    |                |          |    |                |             |    |                |          |    |                |             |  |



## Common Specifications

1. Tach Signal
2. Specification

$V_{psmax}$ : +15VDC  
 $I_p$  max: 5mA [ $V_{LO}$  max = 1.2V]  
 $T_a$  = 25°C

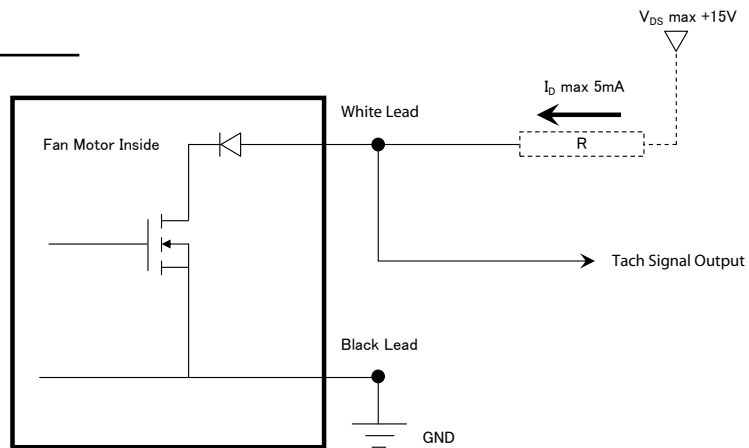
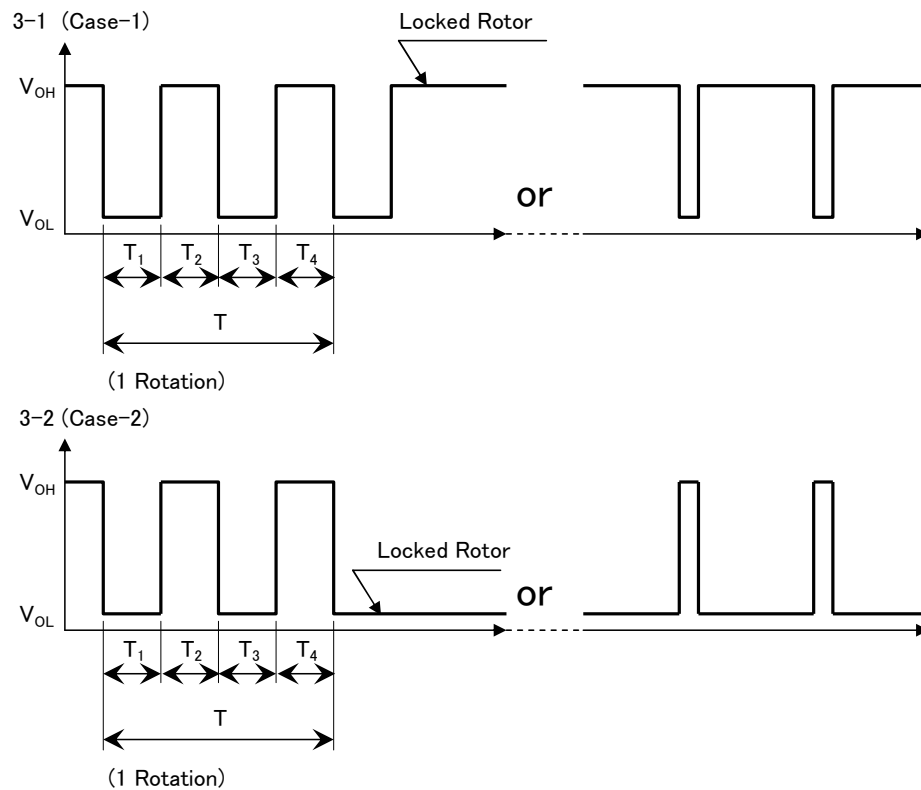


Fig. 1 Tach Signal Circuit

**Warning:** Improper connection of the sensor lead may cause damage to the motor drive IC. We shall be free from compensation, if trouble occurs due to insertion of opposite direction.



- 1.) When the rotor is locked at  $V_{OH}$  position of signal, signal keeps  $V_{OH}$  position or signal becomes to  $V_{OL}$  position for a few seconds at any time of the auto-restart motion.
- 2.) When the rotor is locked at  $V_{OL}$  position of signal, signal keeps  $V_{OL}$  position or signal becomes to  $V_{OH}$  position for a few seconds at any time of the auto-restart motion.
- 3.)  $T = T_1 + T_2 + T_3 + T_4 = 1$  Rotation  
 $T_1 = T_2 = T_3 = T_4 = 60/4m \text{ m}:(\text{min}^{-1})$

## General Specifications

- Motor Protection:**  
Auto Restart/Polarity Protection
- Insulation Resistance:**  
10M Ω or over with a DC500V Megger
- Dielectric Withstand Voltage:** AC 700V 1s
- Allowable Ambient Temperature Range:**  
-10°C ~ +70°C (Operating)  
-40°C ~ +70°C (Storage)

## Expected Life

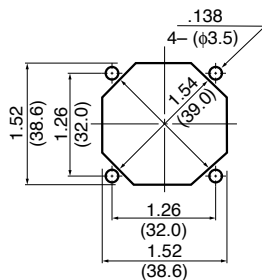
- Failure Rate: 10%**  
25°C 60,000 Hours (B00)

## Material

- Casing : Plastic (Black) 94V-0
- Impeller : Plastic (Black) 94V-0
- Bearing : Ball Bearing
- Lead Wire : UL1061, AWG26, +Red, -Black

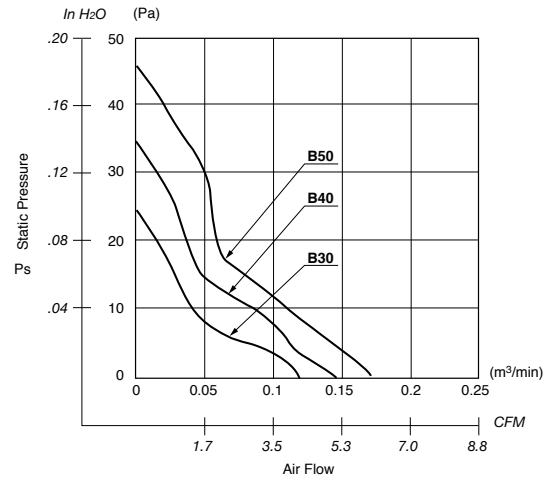
## Panel Cut-Outs

Units:  $\frac{\text{inch}}{\text{(mm)}}$

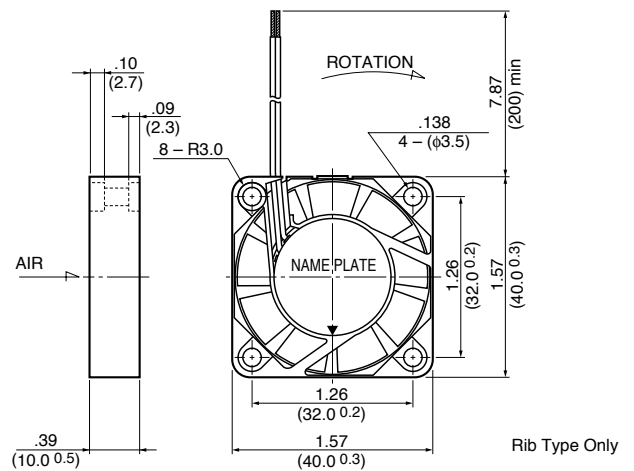


INLET SIDE / OUTLET SIDE

## Characteristic Curves



## Outline



Rib Type Only

## Specifications

MODEL	Product No.	Rated Voltage	Operating Voltage	Current	Input Power	Speed	Max. Air Flow		Max. Static Pressure		Noise	Mass
		(V)	(V)	(A) <sup>*1</sup>	(W) <sup>*1</sup>	(min <sup>-1</sup> ) <sup>*1</sup>	CFM <sup>*1</sup>	(m <sup>3</sup> /min) <sup>*1</sup>	in H <sub>2</sub> O	(Pa) <sup>*1</sup>	(dB) <sup>*1</sup>	(g)
1604KL-01W-B30-	X00	5	4.5 ~ 5.5	0.075	0.375	4500	4.2	0.12	.096	24.0	22.0	15
1604KL-01W-B40-	X00	5	4.5 ~ 5.5	0.120	0.600	5500	5.3	0.15	.136	34.0	25.0	15
1604KL-01W-B50-	X00	5	4.5 ~ 5.5	0.155	0.775	6500	6.0	0.17	.184	46.0	29.0	15
1604KL-04W-B30-	X00	12	10.2 ~ 13.8	0.062	0.744	4500	4.2	0.12	.096	24.0	22.0	15
1604KL-04W-B40-	X00	12	10.2 ~ 13.8	0.073	0.876	5500	5.3	0.15	.136	34.0	25.0	15
1604KL-04W-B50-	X00	12	10.2 ~ 13.8	0.073	0.876	6500	6.0	0.17	.184	46.0	29.0	15

Rotation: Clockwise

Airflow Outlet: Air Out Over Struts

\*1: Average Values in Free Air



## General Specifications

### Motor Protection:

Auto Restart/Polarity Protection

### Insulation Resistance:

10M Ω or over with a DC500V Megger

### Dielectric Withstand Voltage: AC 700V 1s

### Allowable Ambient Temperature Range:

-10°C ~ +70°C (Operating)

-40°C ~ +70°C (Storage)

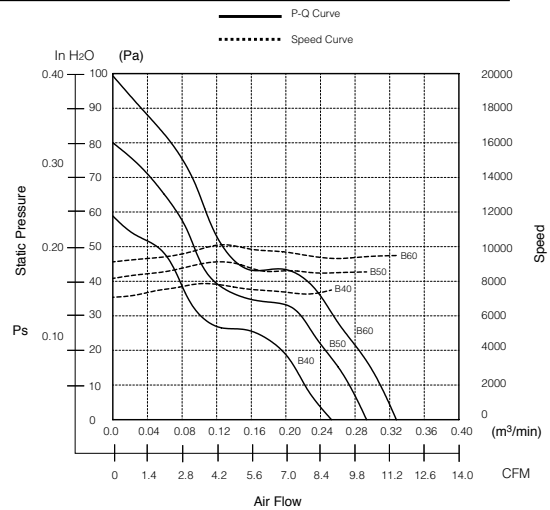
(non-condensing environment)

## Expected Life

### Failure Rate: 10%

25°C 50,000 Hours (B00)

## Characteristic Curves



## Material

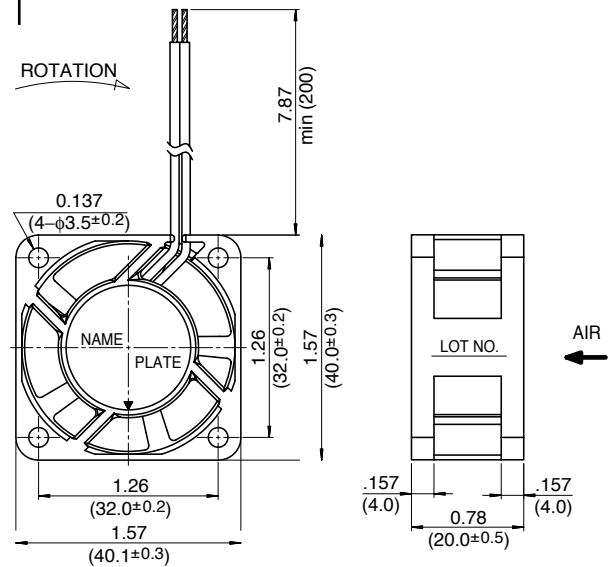
Casing : Plastic (Black) 94V-0

Impeller : Plastic (Black) 94V-0

Bearing : Ball Bearing

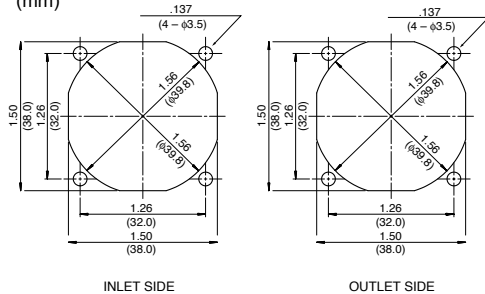
Lead Wire : UL1007, AWG26, +Red, -Black

## Outline



## Panel Cut-Outs

Units: inch (mm)



## Specifications

MODEL	Product No.	Rated Voltage	Operating Voltage	Current	Input Power	Speed	Max. Air Flow		Max. Static Pressure		Noise	Mass
		(V)	(V)	(A) <sup>*1</sup>	(W) <sup>*1</sup>	(min <sup>-1</sup> ) <sup>*1</sup>	CFM <sup>*1</sup>	(m <sup>3</sup> /min) <sup>*1</sup>	in H <sub>2</sub> O	(Pa) <sup>*1</sup>	(dB) <sup>*1</sup>	(g)
1608VL-04W-B40-	BXX	12	7.0 ~ 13.2	0.08	1.02	7500	8.8	0.25	.24	58.8	29.0	40
1608VL-04W-B50-	BXX	12	7.0 ~ 13.2	0.11	1.32	8500	10.2	0.29	.31	76.6	31.4	40
1608VL-04W-B60-	BXX	12	7.0 ~ 13.2	0.13	1.56	9500	11.3	0.32	.40	99.3	34.6	40
1608VL-05W-B40-	BXX	24	14.0 ~ 26.4	0.05	1.20	7500	8.8	0.25	.24	58.8	29.0	40
1608VL-05W-B50-	BXX	24	14.0 ~ 26.4	0.07	1.68	8500	10.2	0.29	.31	76.6	31.4	40
1608VL-05W-B60-	BXX	24	14.0 ~ 26.4	0.10	2.40	9500	11.3	0.32	.40	99.3	34.6	40

Rotation: Clockwise

Airflow Outlet: Air Out Over Struts

\*1: Average Values in Free Air

## General Specifications

### Motor Protection:

Auto Restart/Polarity Protection

### Insulation Resistance:

10M Ω or over with a DC500V Megger

### Dielectric Withstand Voltage: AC 700V 1s

### Allowable Ambient Temperature Range:

-10°C ~ +60°C (Operating)

-40°C ~ +70°C (Storage)

(non-condensing environment)

## Expected Life

### Failure Rate: 10%

40°C 70,000 Hours (B00)

## Material

Casing : Plastic (Black) 94V-0

Impeller : Plastic (Black) 94V-0

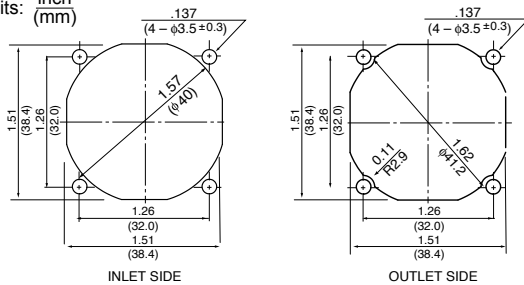
Bearing : Ball Bearing

Lead Wire : UL10368, AWG24, +Red, -Black

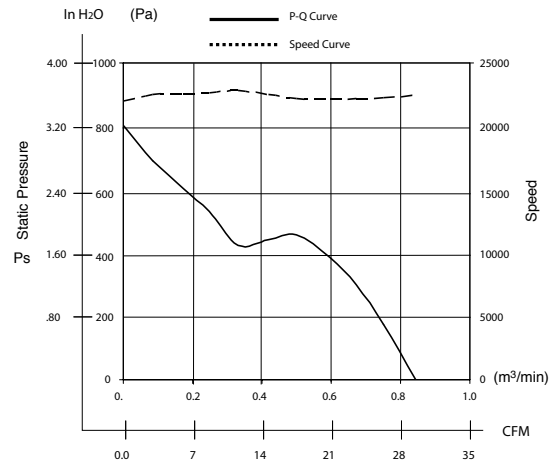
Tach Sig. : White PWM Control : Brown

## Panel Cut-Outs

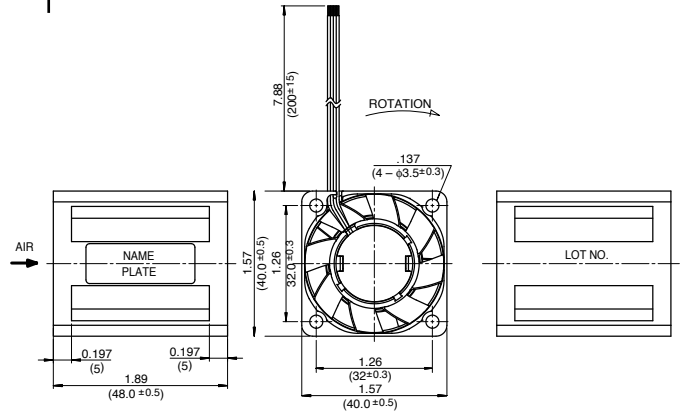
Units: inch  
(mm)



## Characteristic Curves



## Outline



## PWM Control Voltage

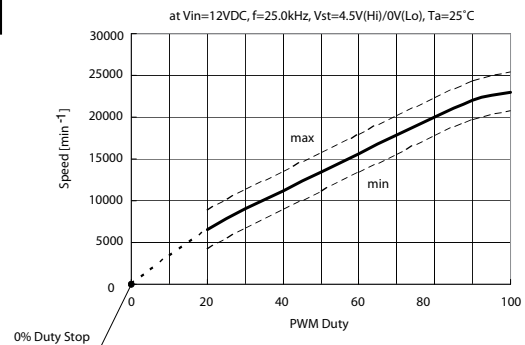
Vst = 0V ~ 0.5V Stop (On Duty 0%)

Vst = 3.3V ~ 5.0V Full Speed (On Duty 100%)

Vst = Open Full Speed

(At Ta = 25°C, rated voltage 12VDC)

## Reference PWM Duty Vs. Speed Curve



## Specifications

MODEL	Product No.	Rated Voltage	Operating Voltage	Current	Input Power	Speed	Max. Air Flow		Max. Static Pressure		Noise	Mass
		(V)	(V)	(A) <sup>*1</sup>	(W) <sup>*1</sup>	(min <sup>-1</sup> ) <sup>*1</sup>	CFM <sup>*1</sup>	(m <sup>3</sup> /min) <sup>*1</sup>	in H <sub>2</sub> O	(Pa) <sup>*1</sup>	(dB) <sup>*1</sup>	(g)
1619FT-04W-B86-	BXX	12	10.8 ~ 13.2	1.05	12.60	23,000	28.9	0.82	3.29	820.0	62.0	71

Rotation: Clockwise

Airflow Outlet: Air Out Over Struts

\*1: Average Values in Free Air

## General Specifications

### Motor Protection:

Auto Restart/Polarity Protection

### Insulation Resistance:

10M Ω or over with a DC500V Megger

### Dielectric Withstand Voltage: AC 700V 1s

### Allowable Ambient Temperature Range:

-10°C ~ +70°C (Operating)

-40°C ~ +70°C (Storage)

(non-condensing environment)

## Expected Life

### Failure Rate: 10%

25°C 100,000 Hours (B00/E00)

## Material

Casing : Plastic (Black) 94V-0

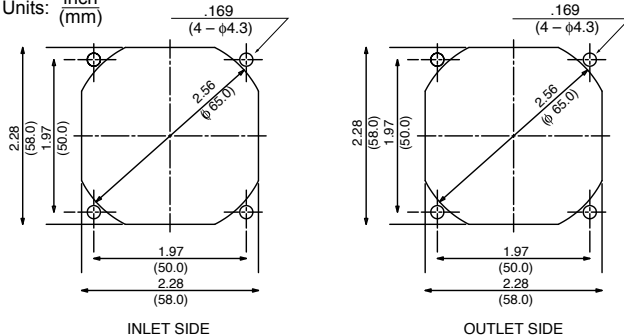
Impeller : Plastic (Black) 94V-0

Bearing : Ball Bearing

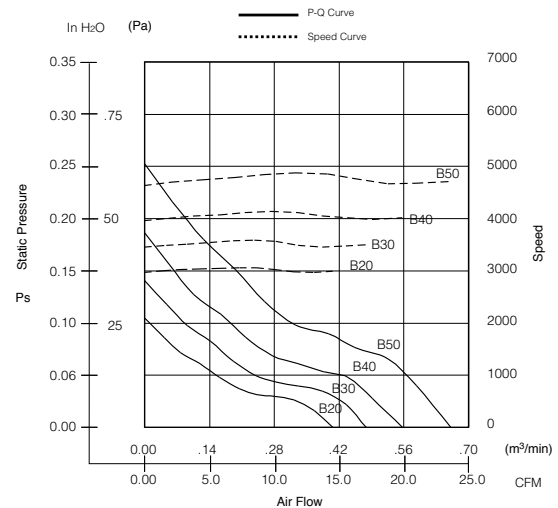
Lead Wire : UL3385, AWG26, +Red, -Black

## Panel Cut-Outs

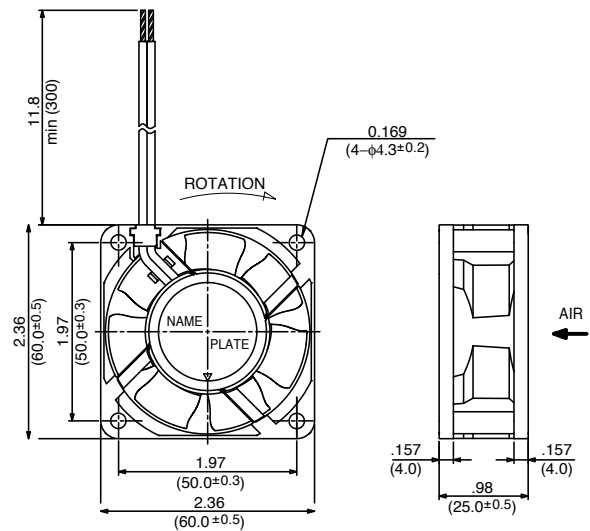
Units: inch (mm)



## Characteristic Curves



## Outline



## Specifications

MODEL	Product No.	Rated Voltage	Operating Voltage	Current	Input Power	Speed	Max. Air Flow		Max. Static Pressure		Noise	Mass
		(V)	(V)	(A) <sup>*1</sup>	(W) <sup>*1</sup>	(min <sup>-1</sup> ) <sup>*1</sup>	CFM <sup>*1</sup>	(m <sup>3</sup> /min) <sup>*1</sup>	in H <sub>2</sub> O	(Pa) <sup>*1</sup>	(dB) <sup>*1</sup>	(g)
2410SB-04W-B20	B/EXX	12	6 ~ 13.8	0.06	0.72	3000	14.5	0.41	0.10	26	17.0	56
2410SB-04W-B30	B/EXX	12	6 ~ 13.8	0.08	0.96	3500	16.9	0.48	0.14	35	22.5	56
2410SB-04W-B40	B/EXX	12	6 ~ 13.8	0.10	1.20	4000	19.8	0.56	0.18	46	26.5	56
2410SB-04W-B50	B/EXX	12	6 ~ 13.8	0.15	1.80	4700	23.3	0.66	0.25	63	32.0	56
2410SB-05W-B20	B/EXX	24	12.0 ~ 27.6	0.03	0.72	3000	14.5	0.41	0.10	26	17.0	56
2410SB-05W-B30	B/EXX	24	12.0 ~ 27.6	0.04	0.96	3500	16.9	0.48	0.14	35	22.5	56
2410SB-05W-B40	B/EXX	24	12.0 ~ 27.6	0.06	1.44	4000	19.8	0.56	0.18	46	26.5	56
2410SB-05W-B50	B/EXX	24	12.0 ~ 27.6	0.08	1.92	4700	23.3	0.66	0.25	63	32.0	56

Rotation: Clockwise

Airflow Outlet: Air Out Over Struts

\*1: Average Values in Free Air

## General Specifications

### Motor Protection:

Auto Restart/Polarity Protection

### Insulation Resistance:

10M Ω or over with a DC500V Megger

### Dielectric Withstand Voltage: AC 700V 1s

### Allowable Ambient Temperature Range:

-10°C ~ +70°C (Operating)

-40°C ~ +70°C (Storage)

(non-condensing environment)

## Expected Life

### Failure Rate: 10%

25°C 100,000 Hours (B00/E00)

## Material

Casing : Plastic (Black) 94V-0

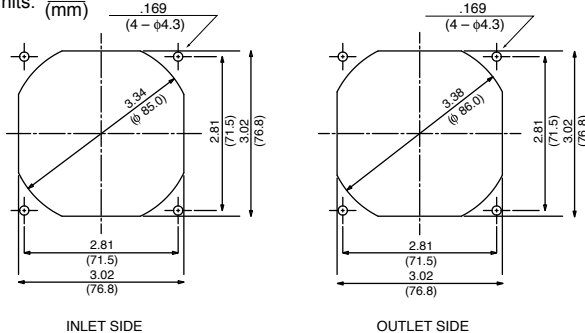
Impeller : Plastic (Black) 94V-0

Bearing : Ball Bearing

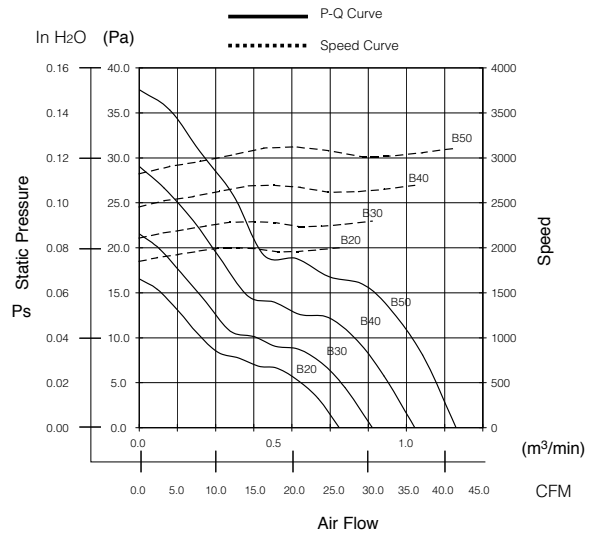
Lead Wire : UL3385, AWG26, +Red, -Black

## Panel Cut-Outs

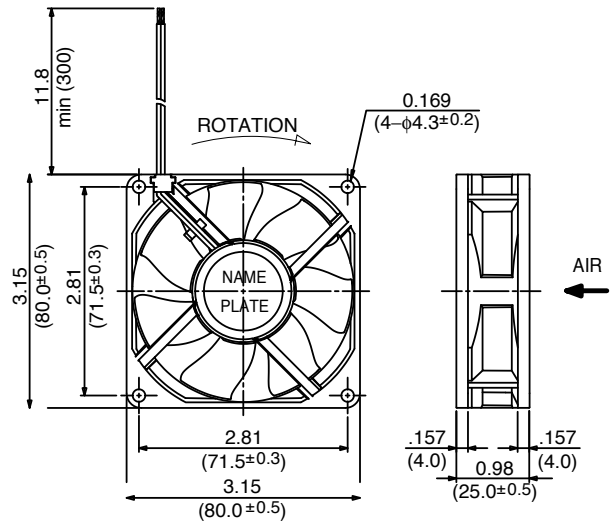
Units: inch (mm)



## Characteristic Curves



## Outline



## Specifications

MODEL	Product No.	Rated Voltage	Operating Voltage	Current	Input Power	Speed	Max. Air Flow		Max. Static Pressure		Noise	Mass
		(V)	(V)	(A) <sup>*1</sup>	(W) <sup>*1</sup>	(min <sup>-1</sup> ) <sup>*1</sup>	CFM <sup>*1</sup>	(m <sup>3</sup> /min) <sup>*1</sup>	in H <sub>2</sub> O	(Pa) <sup>*1</sup>	(dB) <sup>*1</sup>	(g)
3110SB-04W-B20	B/EXX	12	6 ~ 13.8	0.05	0.60	2000	26.1	0.74	0.07	16.5	19.0	80
3110SB-04W-B30	B/EXX	12	6 ~ 13.8	0.06	0.72	2300	30.4	0.86	0.09	21.5	22.0	80
3110SB-04W-B40	B/EXX	12	6 ~ 13.8	0.09	1.08	2700	36.0	1.02	0.12	29.0	26.0	80
3110SB-04W-B50	B/EXX	12	6 ~ 13.8	0.14	1.68	3100	41.3	1.17	0.15	37.5	30.0	80
3110SB-05W-B20	B/EXX	24	12.0 ~ 27.6	0.03	0.72	2000	26.1	0.74	0.07	16.5	19.0	80
3110SB-05W-B30	B/EXX	24	12.0 ~ 27.6	0.04	0.96	2300	30.4	0.86	0.09	21.5	22.0	80
3110SB-05W-B40	B/EXX	24	12.0 ~ 27.6	0.06	1.44	2700	36.0	1.02	0.12	29.0	26.0	80
3110SB-05W-B50	B/EXX	24	12.0 ~ 27.6	0.08	1.92	3100	41.3	1.17	0.15	37.5	30.0	80

Rotation: Clockwise

Airflow Outlet: Air Out Over Struts

\*1: Average Values in Free Air

## General Specifications

### Motor Protection:

Auto Restart/Polarity Protection

### Insulation Resistance:

10M Ω or over with a DC500V Megger

### Dielectric Withstand Voltage: AC 700V 1s

### Allowable Ambient Temperature Range:

-10°C ~ +70°C (Operating)

-40°C ~ +70°C (Storage)

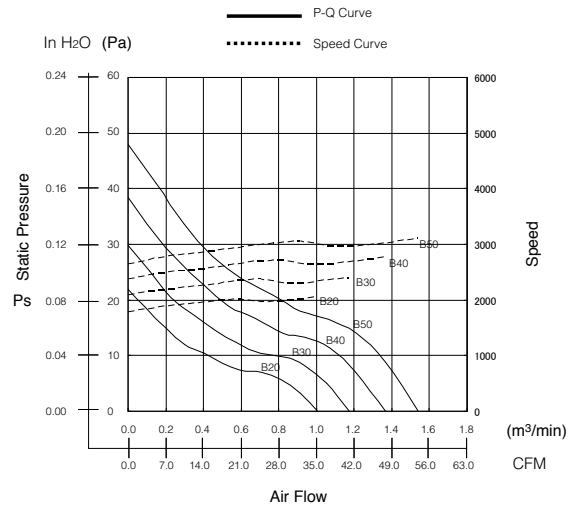
(non-condensing environment)

## Expected Life

### Failure Rate: 10%

25°C 100,000 Hours (B00/E00)

## Characteristic Curves



## Material

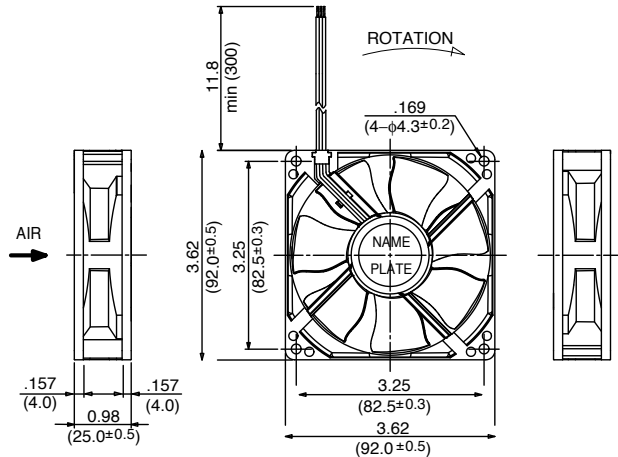
Casing : Plastic (Black) 94V-0

Impeller : Plastic (Black) 94V-0

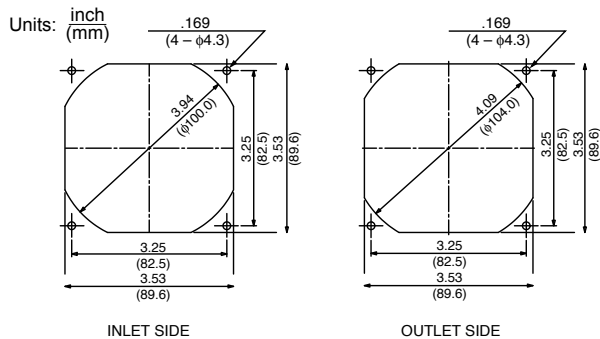
Bearing : Ball Bearing

Lead Wire : UL3385, AWG26, +Red, -Black

## Outline



## Panel Cut-Outs



## Specifications

MODEL	Product No.	Rated Voltage	Operating Voltage	Current	Input Power	Speed	Max. Air Flow		Max. Static Pressure		Noise	Mass
		(V)	(V)	(A) <sup>*1</sup>	(W) <sup>*1</sup>	(min <sup>-1</sup> ) <sup>*1</sup>	CFM <sup>*1</sup>	(m <sup>3</sup> /min) <sup>*1</sup>	in H <sub>2</sub> O	(Pa) <sup>*1</sup>	(dB) <sup>*1</sup>	(g)
3610SB-04W-B20-	B/EXX	12	6 ~ 13.8	0.07	0.84	2050	35.7	1.01	0.09	21.5	25.0	95
3610SB-04W-B30-	B/EXX	12	6 ~ 13.8	0.10	1.20	2400	41.3	1.17	0.12	29.5	28.0	95
3610SB-04W-B40-	B/EXX	12	6 ~ 13.8	0.13	1.56	2750	48.4	1.37	0.15	38.4	32.0	95
3610SB-04W-B50-	B/EXX	12	6 ~ 13.8	0.15	1.80	3100	54.4	1.54	0.19	47.9	35.0	95
3610SB-05W-B20-	B/EXX	24	12 ~ 27.6	0.04	0.84	2050	35.7	1.01	0.09	21.5	25.0	95
3610SB-05W-B30-	B/EXX	24	12 ~ 27.6	0.05	1.20	2400	41.3	1.17	0.12	29.5	28.0	95
3610SB-05W-B40-	B/EXX	24	12 ~ 27.6	0.07	1.56	2750	48.4	1.37	0.15	38.4	32.0	95
3610SB-05W-B50-	B/EXX	24	12 ~ 27.6	0.08	1.80	3100	54.4	1.54	0.19	47.9	35.0	95

Rotation: Clockwise

Airflow Outlet: Air Out Over Struts

\*1: Average Values in Free Air

## General Specifications

### Motor Protection:

Auto Restart/Polarity Protection

### Insulation Resistance:

10M Ω or over with a DC500V Megger

### Dielectric Withstand Voltage: AC 700V 1s

### Allowable Ambient Temperature Range:

-10°C ~ +70°C (Operating)

-40°C ~ +70°C (Storage)

(non-condensing environment)

## Expected Life

### Failure Rate: 10%

25°C 100,000 Hours (B00/E00)

## Material

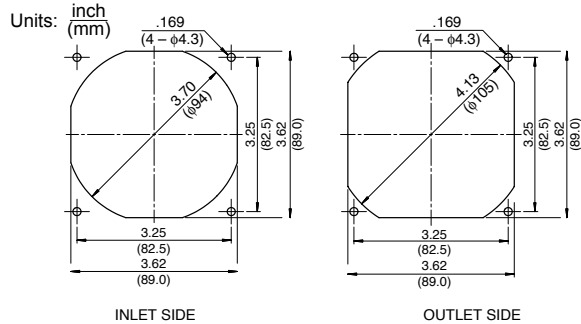
Casing : Plastic (Black) 94V-0

Impeller : Plastic (Black) 94V-0

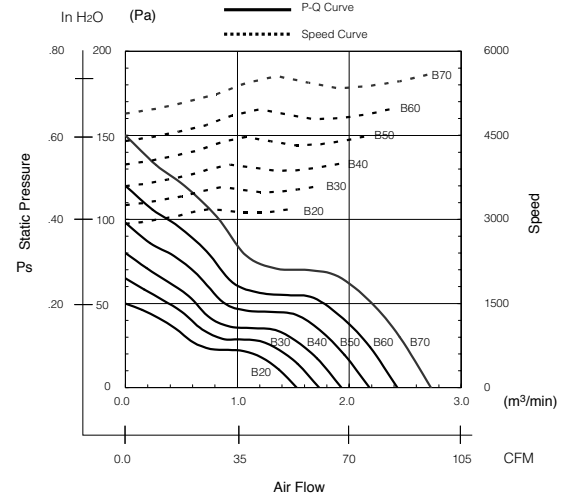
Bearing : Ball Bearing

Lead Wire : UL3385, AWG26, +Red, -Black

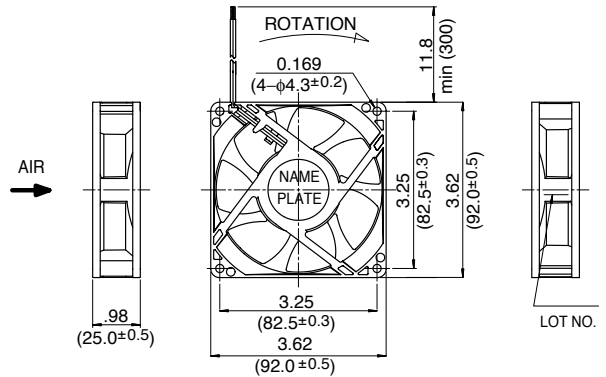
## Panel Cut-Outs



## Characteristic Curves



## Outline



## Specifications

MODEL	Product No.	Rated Voltage	Operating Voltage	Current	Input Power	Speed	Max. Air Flow		Max. Static Pressure		Noise	Mass
		(V)	(V)	(A) <sup>*1</sup>	(W) <sup>*1</sup>	(min <sup>-1</sup> ) <sup>*1</sup>	CFM <sup>*1</sup>	(m <sup>3</sup> /min) <sup>*1</sup>	in H <sub>2</sub> O	(Pa) <sup>*1</sup>	(dB) <sup>*1</sup>	(g)
3610VL-04W-B20-	B/EXX	12	7.0 ~ 13.8	0.18	2.16	3200	54.0	1.53	.20	50	35.5	135
3610VL-04W-B30-	B/EXX	12	7.0 ~ 13.8	0.24	2.88	3600	61.1	1.73	.26	65	38.5	135
3610VL-04W-B40-	B/EXX	12	7.0 ~ 13.8	0.30	3.60	4000	68.1	1.93	.32	80	42.0	135
3610VL-04W-B50-	B/EXX	12	7.0 ~ 13.8	0.40	4.80	4500	77.0	2.18	.39	98	45.0	135
3610VL-04W-B60-	B/EXX	12	7.0 ~ 13.8	0.52	6.24	5000	85.8	2.43	.48	120	48.0	135
3610VL-04W-B70-	B/EXX	12	7.0 ~ 13.8	0.72	8.64	5600	96.4	2.73	.60	150	51.0	135
3610VL-05W-B20-	B/EXX	24	14.0 ~ 27.6	0.11	2.64	3200	54.0	1.53	.20	50	35.5	135
3610VL-05W-B30-	B/EXX	24	14.0 ~ 27.6	0.14	3.36	3600	61.1	1.73	.26	65	38.5	135
3610VL-05W-B40-	B/EXX	24	14.0 ~ 27.6	0.17	4.08	4000	68.1	1.93	.32	80	42.0	135
3610VL-05W-B50-	B/EXX	24	14.0 ~ 27.6	0.22	5.28	4500	77.0	2.18	.39	98	45.0	135
3610VL-05W-B60-	B/EXX	24	14.0 ~ 27.6	0.28	6.72	5000	85.8	2.43	.48	120	48.0	135
3610VL-05W-B70-	B/EXX	24	14.0 ~ 27.6	0.38	9.12	5600	96.4	2.73	.60	150	51.0	135

Rotation: Clockwise

Airflow Outlet: Air Out Over Struts

\*1: Average Values in Free Air

## General Specifications

### Motor Protection:

Auto Restart/Polarity Protection

### Insulation Resistance:

10M Ω or over with a DC500V Megger

### Dielectric Withstand Voltage: AC 700V 1s

### Allowable Ambient Temperature Range:

B50 Class: -10°C ~ +40°C (Operating)

B10 ~ B40 Class: -10°C ~ +70°C (Operating)

B10 ~ B40 Class: -40°C ~ +70°C (Storage)

B50 Class: -40°C ~ +60°C (Storage)

(non-condensing environment)

## Expected Life

### Failure Rate: 10%

25°C 50,000 Hours (P00)

## Material

Casing : Plastic (Black) 94V-0

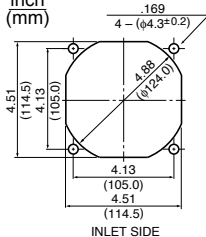
Impeller : Plastic (Black) 94V-0

Bearing : Ball Bearing

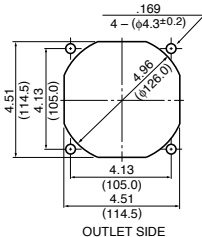
Lead Wire : UL1007, AWG24, +Red, -Black

## Panel Cut-Outs

Units:  
inch  
(mm)

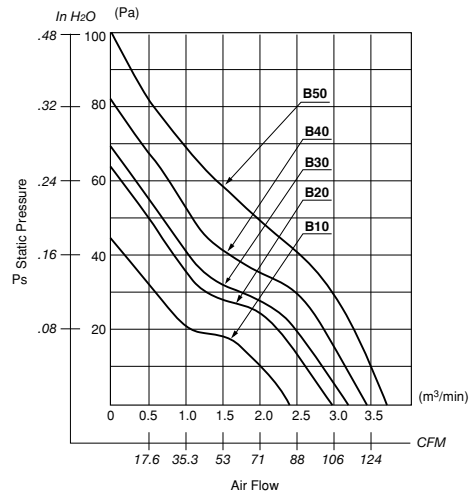


INLET SIDE

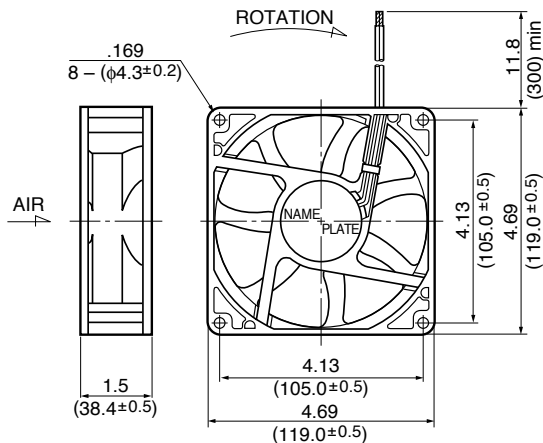


OUTLET SIDE

## Characteristic Curves



## Outline



## Specifications

MODEL	Rated Voltage	Operating Voltage	Current	Input Power	Speed	Max. Air Flow		Max. Static Pressure		Noise	Mass
						CFM <sup>1</sup>	(m <sup>3</sup> /min) <sup>1</sup>	in H <sub>2</sub> O	(Pa) <sup>1</sup>		
4715KL-04W-B10-	12	6.0 ~ 13.8	0.27	3.24	2300	83.6	2.37	.17	44.1	37.0	260
4715KL-04W-B20-	12	6.0 ~ 13.8	0.40	4.80	2650	97.0	2.75	.22	55.9	41.0	260
4715KL-04W-B30-	12	6.0 ~ 13.8	0.55	6.60	2950	108.0	3.07	.27	68.2	42.5	260
4715KL-04W-B40-	12	6.0 ~ 13.8	0.70	8.40	3200	118.0	3.34	.33	81.4	46.5	260
4715KL-04W-B50-	12	9.5 ~ 12.6	1.00	12.00	3600	129.9	3.68	.44	110.0	50.0	260
4715KL-05W-B10-	24	10.0 ~ 27.6	0.15	3.60	2300	83.6	2.37	.17	44.1	37.0	260
4715KL-05W-B20-	24	10.0 ~ 27.6	0.21	5.04	2650	97.0	2.75	.22	55.9	41.0	260
4715KL-05W-B30-	24	10.0 ~ 27.6	0.31	7.44	2950	108.0	3.07	.27	68.2	42.5	260
4715KL-05W-B40-	24	10.0 ~ 27.6	0.35	8.40	3200	118.0	3.34	.33	81.4	46.5	260
4715KL-05W-B50-	24	18.0 ~ 25.0	0.50	12.00	3600	130.0	3.68	.44	110.0	50.0	260
4715KL-07W-B10-	48	25.0 ~ 55.2	0.08	3.84	2300	83.6	2.37	.17	44.1	37.0	260
4715KL-07W-B20-	48	25.0 ~ 55.2	0.11	5.28	2650	97.0	2.75	.22	55.9	41.0	260
4715KL-07W-B30-	48	25.0 ~ 55.2	0.16	7.68	2950	108.0	3.07	.27	68.2	42.5	260
** 4715KL-07W-B40-	48	25.0 ~ 55.2	0.20	9.60	3200	118.0	3.34	.33	81.4	46.5	260
4715KL-07W-B50-	48	30.0 ~ 60.0	0.16	7.68	3600	130.0	3.68	.44	110.0	50.0	260

Rotation: Clockwise

Airflow Outlet: Air Out Over Struts

\*1: Average Values in Free Air

\*\* Contact NMB for availability

### General Specifications

#### Motor Protection:

Auto Restart/Polarity Protection

#### Insulation Resistance:

10M  $\Omega$  or over with a DC500V Megger

#### Dielectric Withstand Voltage: AC 700V 1s

#### Allowable Ambient Temperature Range:

B50, B40 Class: -10°C ~ +45°C (Operating)

B30 Class: -10°C ~ +50°C (Operating)

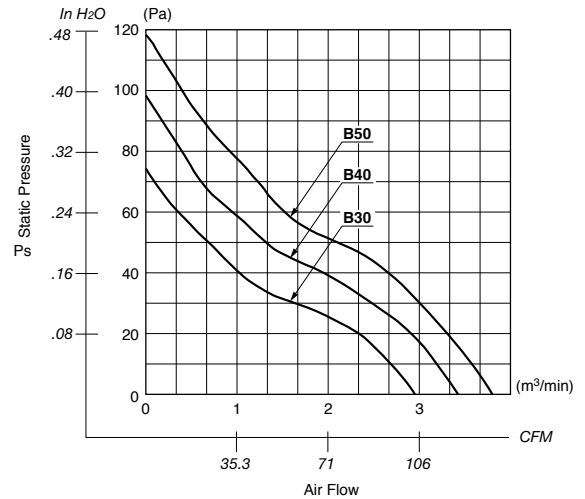
All Class: -40°C ~ +60°C (Storage)

### Expected Life

#### Failure Rate: 10%

25°C 100,000 Hours (R00)

### Characteristic Curves



### Material

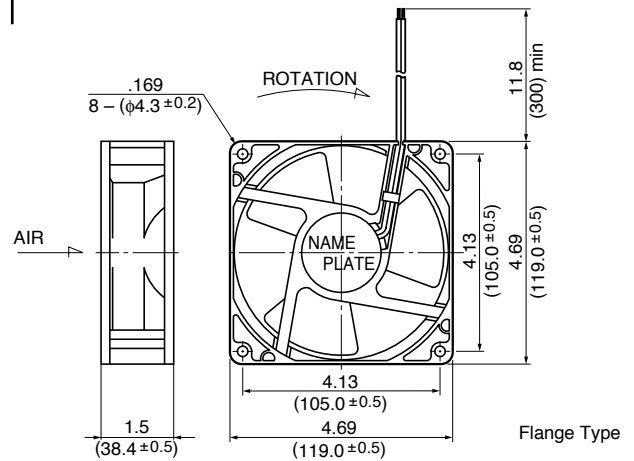
Casing : Plastic (Black) 94V-0

Impeller : Plastic (Black) 94V-0

Bearing : Ball Bearing

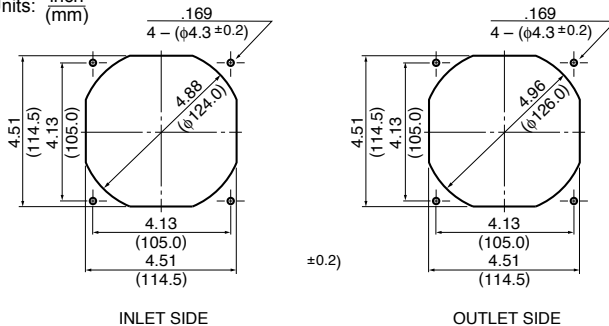
Lead Wire : UL1007, AWG26, +Red, -Black

### Outline



### Panel Cut-Outs

Units: inch (mm)



### Specifications

MODEL	Product No.	Rated Voltage	Operating Voltage	Current	Input Power	Speed	Max. Air Flow		Max. Static Pressure		Noise	Mass
		(V)	(V)	(A) <sup>*1</sup>	(W) <sup>*1</sup>	(min <sup>-1</sup> ) <sup>*1</sup>	CFM <sup>*1</sup>	(m <sup>3</sup> /min) <sup>*1</sup>	in H <sub>2</sub> O	(Pa) <sup>*1</sup>	(dB) <sup>*1</sup>	(g)
4715KL-04W-B50-	R00	12	9.5 ~ 12.6	0.85	10.2	3900	132.0	3.73	.45	113.0	54.0	260
4715KL-05W-B50-	R00	24	20.0 ~ 25.0	0.48	11.5	3900	132.0	3.73	.45	113.0	54.0	260
** 4715KL-07W-B30-	R00	48	25.0 ~ 55.2	0.13	6.24	3100	105.0	2.97	.30	74.0	47.0	260
** 4715KL-07W-B40-	R00	48	25.0 ~ 50.4	0.16	7.68	3500	121.0	3.44	.39	97.5	51.0	260
** 4715KL-07W-B50-	R00	48	36.0 ~ 50.0	0.20	9.60	3900	132.0	3.73	.45	113.0	54.0	260

Rotation: Clockwise

Airflow Outlet: Air Out Over Struts

\*1: Average Values in Free Air

\*\* Contact NMB for availability



## General Specifications

### Motor Protection:

Auto Restart/Polarity Protection

### Insulation Resistance:

10M Ω or over with a DC500V Megger

### Dielectric Withstand Voltage: AC 700V 1s

### Allowable Ambient Temperature Range:

-10°C ~ +70°C (Operating)

-40°C ~ +70°C (Storage)

(non-condensing environment)

## Expected Life

### Failure Rate: 10%

25°C 100,000 Hours (E00)

## Material

Casing : Plastic (Black) 94V-0

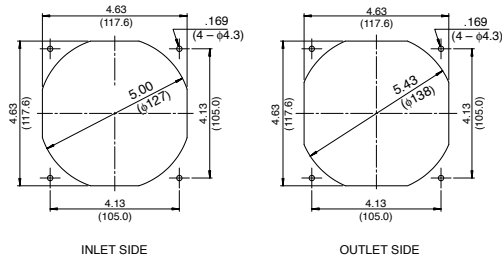
Impeller : Plastic (Black) 94V-0

Bearing : Ball Bearing

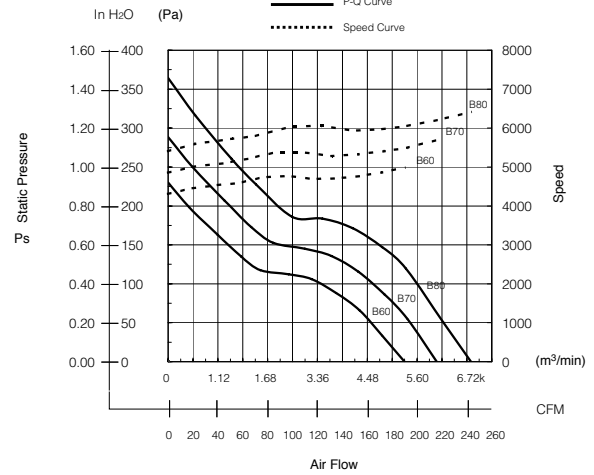
Lead Wire : UL1061, AWG24, +Red, -Black

## Panel Cut-Outs

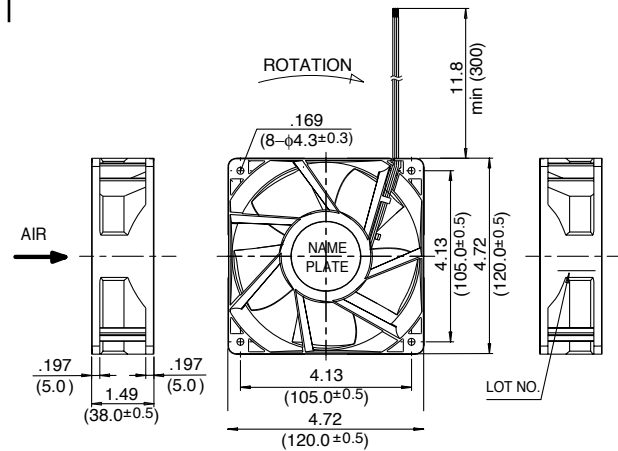
Units:  $\frac{\text{inch}}{\text{(mm)}}$



## Characteristic Curves



## Outline



## Specifications

MODEL	Product No.	Rated Voltage	Operating Voltage	Current	Input Power	Speed	Max. Air Flow		Max. Static Pressure		Noise	Mass
		(V)	(V)	(A) <sup>1</sup>	(W) <sup>1</sup>	(min <sup>-1</sup> ) <sup>1</sup>	CFM <sup>1</sup>	(m <sup>3</sup> /min) <sup>1</sup>	in H <sub>2</sub> O	(Pa) <sup>1</sup>	(dB) <sup>1</sup>	(g)
4715VL-04W-B60-	EXX	12	10.0 ~ 13.8	1.50	18.00	5000	189.9	5.38	0.92	229	59.5	370
4715VL-04W-B70-	EXX	12	10.0 ~ 13.8	2.25	27.00	5700	215.7	6.11	1.15	287	63.0	370
4715VL-04W-B80-	EXX	12	10.0 ~ 12.6	3.00	36.00	6400	243.2	6.89	1.46	363	66.0	370
4715VL-05W-B50-	EXX	24	18.0 ~ 27.6	0.76	18.24	4700	182.5	5.17	0.83	207	55.5	370
4715VL-05W-B60-	EXX	24	18.0 ~ 27.6	0.74	17.76	5000	189.9	5.38	0.92	229	59.5	370
4715VL-05W-B70-	EXX	24	18.0 ~ 27.6	1.04	24.96	5700	215.7	6.11	1.15	287	63.0	370
4715VL-05W-B80-	EXX	24	18.0 ~ 27.6	1.48	35.52	6400	243.2	6.89	1.46	363	66.0	370
4715VL-07W-B50-	EXX	48	40.0 ~ 52.8	0.37	17.80	4700	182.5	5.17	0.83	207	55.5	370
4715VL-07W-B60-	EXX	48	40.0 ~ 55.2	0.45	21.60	5000	189.9	5.38	0.92	229	59.5	370
4715VL-07W-B70-	EXX	48	40.0 ~ 55.2	0.60	28.80	5700	215.7	6.11	1.15	287	63.0	370
4715VL-07W-B80-	EXX	48	40.0 ~ 52.0	0.80	38.40	6400	243.2	6.89	1.46	363	66.0	370

Rotation: Clockwise

Airflow Outlet: Air Out Over Struts

\*1: Average Values in Free Air

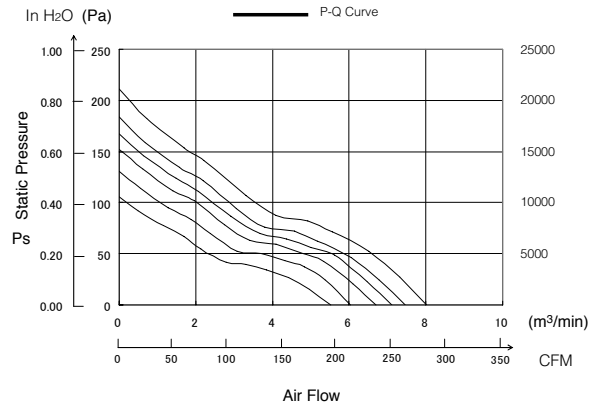
### General Specifications

- Motor Protection:**  
Auto Restart/Polarity Protection
- Insulation Resistance:**  
10M Ω or over with a DC500V Megger
- Dielectric Withstand Voltage:** AC 700V 1s
- Allowable Ambient Temperature Range:**  
-10°C ~ +70°C (Operating)  
-40°C ~ +70°C (Storage)  
(non-condensing environment)

### Expected Life

- Failure Rate: 10%**  
25°C 100,000 Hours (D00)

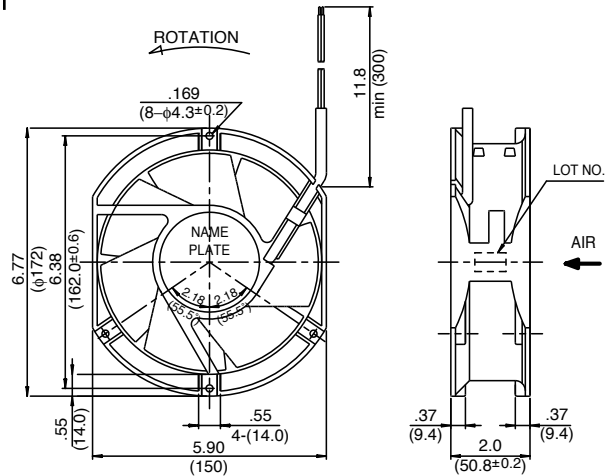
### Characteristic Curves



### Material

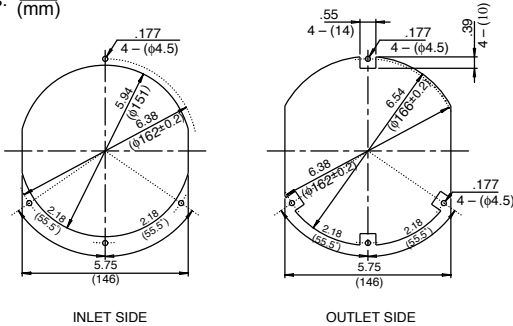
- Casing : Plastic (Black) 94V-0
- Impeller : Plastic (Black) 94V-0
- Bearing : Ball Bearing
- Lead Wire : UL1007, AWG26, +Red, -Black

### Outline



### Panel Cut-Outs

Units: inch (mm)



### Specifications

MODEL	Product No.	Rated Voltage	Operating Voltage	Current	Input Power	Speed	Max. Air Flow		Max. Static Pressure		Noise	Mass
		(V)	(V)	(A) <sup>*1</sup>	(W) <sup>*1</sup>	(min <sup>-1</sup> ) <sup>*1</sup>	CFM <sup>*1</sup>	(m <sup>3</sup> /min) <sup>*1</sup>	in H <sub>2</sub> O	(Pa) <sup>*1</sup>	(dB) <sup>*1</sup>	(g)
5920VL-07W-B10-	DXX	48	36 ~ 56	0.28	13.44	2550	194.5	5.51	.43	106	51.0	830
5920VL-07W-B20-	DXX	48	36 ~ 56	0.33	15.84	2850	213.2	6.04	.53	131	54.0	830
5920VL-07W-B30-	DXX	48	36 ~ 56	0.37	17.76	3150	236.5	6.70	.61	152	57.0	830
5920VL-07W-B40-	DXX	48	36 ~ 56	0.41	19.68	3350	251.0	7.11	.67	167	59.0	830
5920VL-07W-B50-	DXX	48	36 ~ 56	0.44	21.10	3500	263.3	7.46	.74	184	61.0	830
5920VL-07W-B60-	DXX	48	36 ~ 56	0.52	25.00	3750	283.1	8.02	.85	211	63.0	830

Rotation: Counterclockwise

Airflow Outlet: Air Out Over Struts

\*1: Average Values in Free Air

## Common Specifications

- Vibration Test: ..... Conforms to JIS C 60068-2-6, Amplitude: 1.5mm, Frequency 10 to 55 Hz, 1 hour in each of the X, Y and Z directions.
- Shock Test: ..... Conforms to JIS C 60068-2-27, Acceleration rate: 981 m/s<sup>2</sup>\*, Application time: 6ms once each in the X, Y and Z directions. Note: For the BM4515, BM5115, BM5125 and BM6015 series, the conditions of the shock test are as follows: Acceleration rate 500 m/s<sup>2</sup>, Application time: 11ms once each in the X, Y and Z directions.
- Locked Rotor Protection : .. The motor is protected from burnout in the locked rotor condition for 72 hours, at the rated voltage.
- Polarity Protection : ..... The fans are Reverse Polarity protected at the rated voltage.
- Insulation Class : ..... E class (UL: Class A)
- Auto Restart:..... Most fan models provide current shut-down/auto restart function under locked rotor conditions.

Notes: Additional performance requirements can be determined between manufacturer and customer, based on customer's request.  
Ball bearing fans and blowers may be installed in a horizontal, vertical or angled position

## BM Part Numbering System

BM 51 15 - 04 W - B 3 0 - L 00  
 ① ② ③ ④ ⑤ ⑥ ⑦ ⑧ ⑨ ⑩

- |  |   |   |  |
|--|---|---|--|
| <p><b>1. Series</b><br/>BM Series</p> <p><b>2. Size</b><br/>45: 45mm<br/>51: 51mm<br/>60: 60mm</p> <p><b>3. Thickness</b><br/>15: 15mm<br/>25: 25mm</p> <p><b>4. Input Voltage</b><br/>O: Standard Current<br/>C: Special Current<br/>D~Z: Special Current<br/>(A.B.O. are not used)</p> | <p><b>5. Termination</b><br/>Lead Wire</p> <p><b>6. Bearing</b><br/>B: Ball Bearing<br/>S: Sleeve Bearing</p> <p><b>7. Speed</b><br/>1&lt;2&lt;3&lt;4&lt;5<br/>low high</p> | <p><b>8. Special Control Function</b><br/>0: Standard Type<br/>9: Sensor Type<br/>8: 2-Speed Type<br/>7: Temperature Detecting Variable Speed Type/PWM Control Type<br/>6: Temperature Detecting Variable Speed Type/Sensor Type<br/>5: 2-Speed Type/Sensor Type</p> <p><b>9. Classification</b><br/>L-Standard Model/Rib Type<br/>T-Value Model/Rib Type</p> | <p><b>10. Individual Specifications</b><br/>Standard Type<br/>00: Standard<br/>01~99: Custom<br/>Sensor Type<br/>00: Locked Rotor Alarm Signal (Standard Type)<br/>01~49: Locked Rotor Alarm Signal (Custom Type)<br/>50: Tachometer Signal (Standard Type)<br/>51~99: Tachometer Signal (Custom Type)</p> |
|--|---|---|--|

## BG Part Numbering System

BG 07 03 - B 04 - 4 - 000 - 00  
 ① ② ③ ④ ⑤ ⑥ ⑦ ⑧

- |   |   |  |   |
|---|---|--|---|
| <p><b>1. Series</b><br/>BG Series</p> <p><b>2. Size</b><br/>07: 75mm<br/>08: 80mm<br/>09: 95mm<br/>10: 100mm<br/>12: 120mm</p> <p><b>3. Thickness</b><br/>01: 18mm<br/>02: 25mm<br/>03: 30~33mm</p> | <p><b>4. Bearing</b><br/>B: Ball Bearing<br/>S: Sleeve Bearing</p> <p><b>5. Input Voltage</b><br/>O: Standard Current<br/>C: Special Current<br/>D~Z: Special Current<br/>(A.B.O. are not used)</p> <p>1: 5V 5: 24V<br/>2: 6V 6: 36V<br/>3: 9V 7: 48V<br/>4: 12V 9: Other</p> | <p><b>6. Speed</b><br/>1&lt;2&lt;3&lt;4&lt;5<br/>low high</p> <p><b>7. Special Control Function</b><br/>0 0 0<br/>A B C<br/>A: Special Control Function<br/>O: Fix Speed Type<br/>2: 2-Speed Type<br/>V: Temperature Detecting Variable Speed Type<br/>P: PWM Control Type</p> | <p>B: Thermistor Mounting Position<br/>O: No Thermistor<br/>T: Thermistor On PCB<br/>C: Output Signal<br/>O: No Signal<br/>L: Locked Rotor Alarm Signal<br/>S: Tachometer Signal</p> <p><b>8. Product Number</b><br/>00: Standard<br/>01~ : Customized Standard<br/>T0: Standard Value<br/>T1~ : Customized Value</p> |
|---|---|--|---|

## General Specifications

### Motor Protection:

Auto Restart/Polarity Protection

### Insulation Resistance:

10M Ω or over with a DC500V Megger

### Dielectric Withstand Voltage: AC 700V 1s

### Allowable Ambient Temperature Range:

-10°C ~ +60°C (Operating)

-40°C ~ +70°C (Storage)

(non-condensing environment)

## Expected Life

### Failure Rate: 10%

25°C 50,000 Hours (L00)

## Material

Casing : Plastic (Black) 94V-0

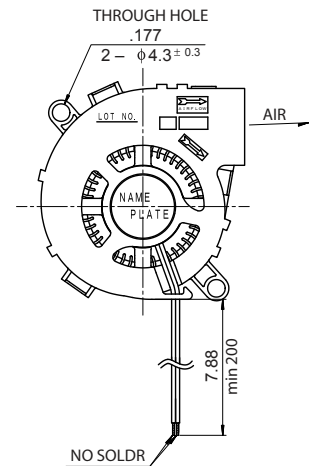
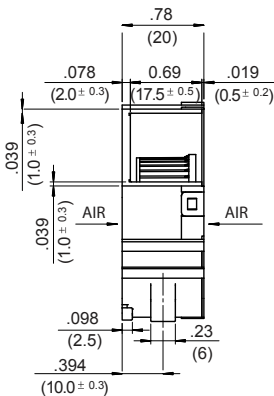
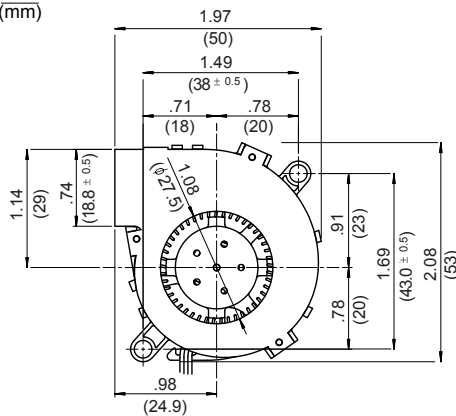
Impeller : Plastic (Black) 94V-0

Bearing : Ball Bearing

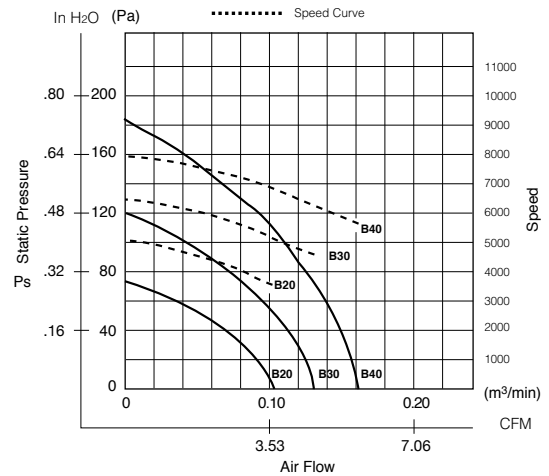
Lead Wire : UL1061, AWG26, +Red, -Black

## Outline

Units:  $\frac{\text{inch}}{\text{(mm)}}$



## Characteristic Curves



## Specifications

MODEL	Product No.	Rated Voltage	Operating Voltage	Current	Input Power	Speed	Max. Air Flow		Max. Static Pressure		Noise	Mass
		(V)	(V)	(A) <sup>*1</sup>	(W) <sup>*1</sup>	(min <sup>-1</sup> ) <sup>*1</sup>	CFM <sup>*1</sup>	(m <sup>3</sup> /min) <sup>*1</sup>	in H <sub>2</sub> O	(Pa) <sup>*1</sup>	(dB) <sup>*1</sup>	(g)
BM5020-01W-B30-	L00	5	4.5 ~ 5.5	0.34	1.70	4600	4.6	0.13	.50	124	27.0	30
BM5020-04W-B20-	L00	12	4.5 ~ 13.8	0.07	0.84	3600	3.5	0.10	.30	75	20.0	30
BM5020-04W-B30-	L00	24	4.5 ~ 13.8	0.12	1.44	4600	4.6	0.13	.50	124	27.0	30
BM5020-04W-B40-	L00	24	4.5 ~ 13.8	0.18	2.16	5600	5.6	0.16	.74	184	32.0	30
BM5020-05W-B40-	L00	24	12.0 ~ 25.2	0.08	1.92	5600	5.6	0.16	.74	184	32.0	30

Rotation: Counterclockwise

\*1: Average Values in Free Air

## General Specifications

### Motor Protection:

Auto Restart/Polarity Protection

### Insulation Resistance:

10M Ω or over with a DC500V Megger

### Dielectric Withstand Voltage: AC 700V 1s

### Allowable Ambient Temperature Range:

-10°C ~ +70°C (Operating)

-40°C ~ +70°C (Storage)

(non-condensing environment)

## Expected Life

### Failure Rate: 10%

25°C 70,000 Hours (00)

## Material

Casing : Plastic (Black) 94V-0

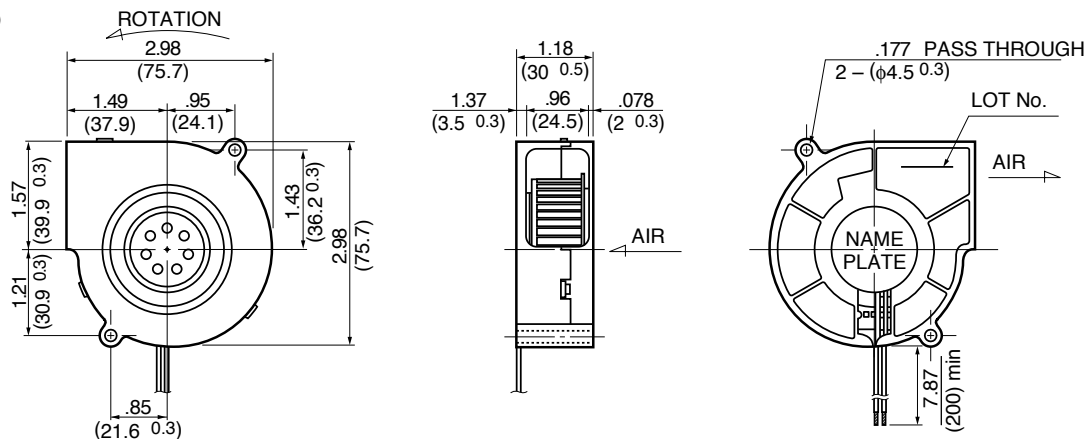
Impeller : Plastic (Black) 94V-0

Bearing : Ball Bearing

Lead Wire : UL1007, AWG26, +Red, -Black

## Outline

Units:  $\frac{\text{inch}}{\text{mm}}$



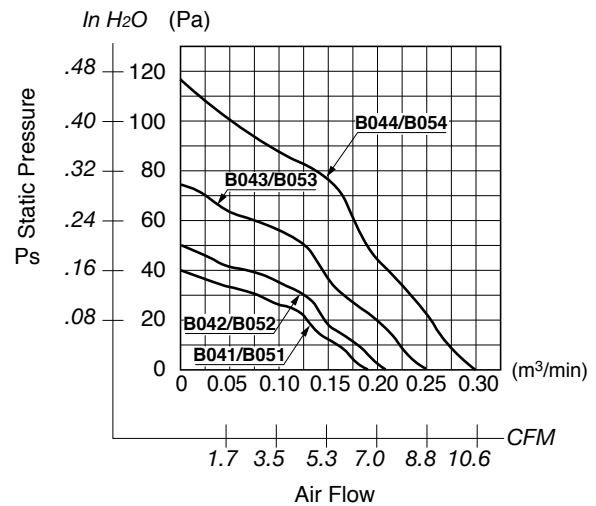
## Specifications

MODEL	Product No.	Rated Voltage	Operating Voltage	Current	Input Power	Speed	Max. Air Flow		Max. Static Pressure		Noise	Mass
		(V)	(V)	(A) <sup>*1</sup>	(W) <sup>*1</sup>	(min <sup>-1</sup> ) <sup>*1</sup>	CFM <sup>*1</sup>	(m <sup>3</sup> /min) <sup>*1</sup>	in H <sub>2</sub> O	(Pa) <sup>*1</sup>	(dB) <sup>*1</sup>	(g)
BG0703-B041-000-	X0	12	6 ~ 13.8	0.10	1.20	2000	6.7	0.19	.16	40	28.0	90
BG0703-B042-000-	X0	12	6 ~ 13.8	0.12	1.44	2200	7.4	0.21	.20	50	29.5	90
BG0703-B043-000-	X0	12	6 ~ 13.8	0.18	2.16	2550	8.8	0.25	.30	75	34.5	90
BG0703-B044-000-	X0	12	6 ~ 13.0	0.29	3.48	3000	10.6	0.30	.44	110	38.5	90
BG0703-B051-000-	X0	24	10 ~ 27.6	0.06	1.44	2000	6.7	0.19	.16	40	28.0	90
BG0703-B052-000-	X0	24	10 ~ 27.6	0.07	1.68	2200	7.4	0.21	.20	50	29.5	90
BG0703-B053-000-	X0	24	10 ~ 27.6	0.09	2.16	2550	8.8	0.25	.30	75	34.5	90
BG0703-B054-000-	X0	24	10 ~ 26.0	0.15	3.60	3000	10.6	0.30	.44	110	38.5	90

Rotation: Counterclockwise

\*1: Average Values in Free Air

## Characteristic Curves



### General Specifications

- Motor Protection:**  
Auto Restart/Polarity Protection
- Insulation Resistance:**  
10M Ω or over with a DC500V Megger
- Dielectric Withstand Voltage:** AC 700V 1s
- Allowable Ambient Temperature Range:**  
-10°C ~ +60°C (Operating)  
-40°C ~ +70°C (Storage)  
(non-condensing environment)

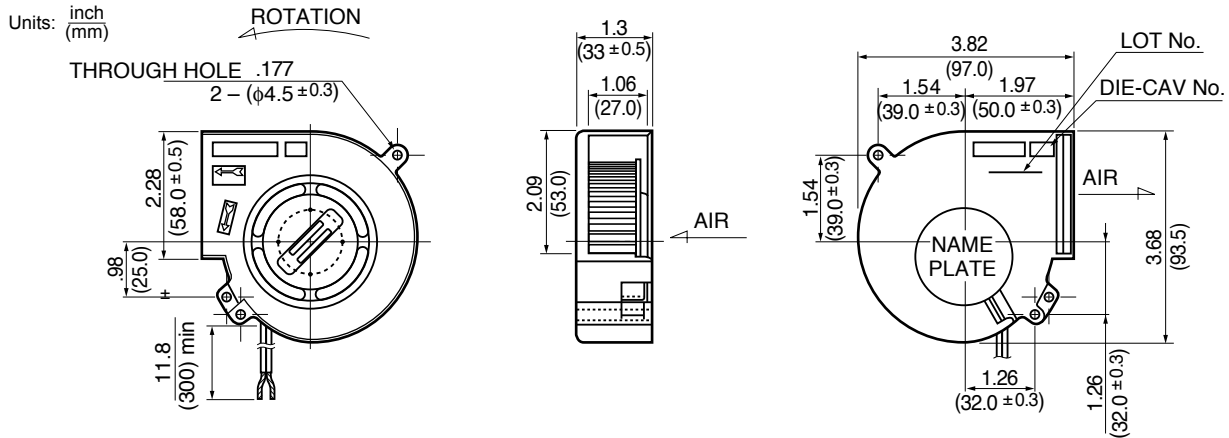
### Expected Life

**Failure Rate: 10%**  
25°C 100,000 Hours (00)

### Material

- Casing : Plastic (Black) 94V-0
- Impeller : Plastic (Black) 94V-0
- Bearing : Ball Bearing
- Lead Wire : UL1007, AWG26, +Red, -Black

### Outline



### Specifications

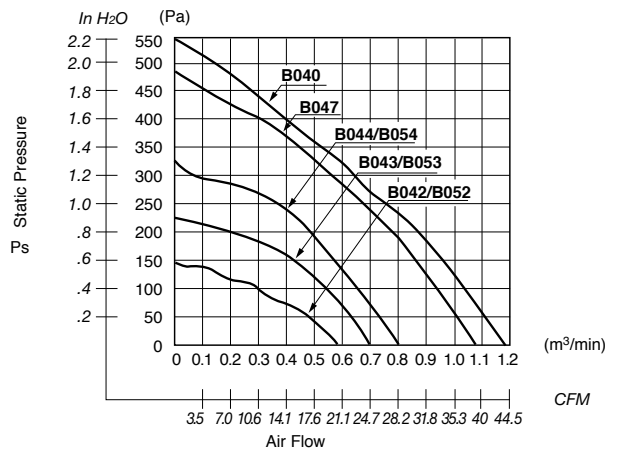
MODEL	Product No.	Rated Voltage	Operating Voltage	Current	Input Power	Speed	Max. Air Flow		Max. Static Pressure		Noise	Mass
		(V)	(V)	(A) <sup>*1</sup>	(W) <sup>*1</sup>	(min <sup>-1</sup> ) <sup>*1</sup>	CFM <sup>*1</sup>	(m <sup>3</sup> /min) <sup>*1</sup>	in H <sub>2</sub> O	(Pa) <sup>*1</sup>	(dB) <sup>*1</sup>	(g)
BG0903-B042-000-	00	12	8 ~ 13.8	0.40	4.80	2700	20.5	0.58	.61	152	47.5	210
BG0903-B043-000-	00	12	8 ~ 13.8	0.64	7.68	3200	24.7	0.70	.90	225	51.5	210
BG0903-B044-000-	00	12	8 ~ 12.6	1.03	12.40	3700	28.6	0.81	1.4	342	54.5	210
BG0903-B052-000-	00	24	10 ~ 27.6	0.21	5.04	2700	20.5	0.58	.61	152	47.5	210
BG0903-B053-000-	00	24	10 ~ 27.6	0.33	7.92	3200	24.7	0.70	.90	225	51.5	210
BG0903-B054-000-	00	24	10 ~ 25.0	0.49	11.80	3700	28.6	0.81	1.4	342	54.5	210
<b>HIGH SPEED</b>												
** BG0903-B040-000-	00	12	10.8 ~ 13.6	2.4	28.90	5700	42.0	1.19	2.2	549	65	210
** BG0903-B047-000-	00	12	10.8 ~ 12.6	1.6	19.20	5200	38.1	1.08	1.9	482	-	210

Rotation: Counterclockwise

\*1: Average Values in Free Air

\*\* Contact NMB for availability

### Characteristic Curves



## General Specifications

### Motor Protection:

Auto Restart/Polarity Protection

### Insulation Resistance:

10M Ω or over with a DC500V Megger

### Dielectric Withstand Voltage: AC 700V 1s

### Allowable Ambient Temperature Range:

-10°C ~ +60°C (Operating)

-40°C ~ +70°C (Storage)

(non-condensing environment)

## Expected Life

### Failure Rate: 10%

25°C 100,000 Hours (00)

## Material

Casing : Plastic (Black) 94V-0

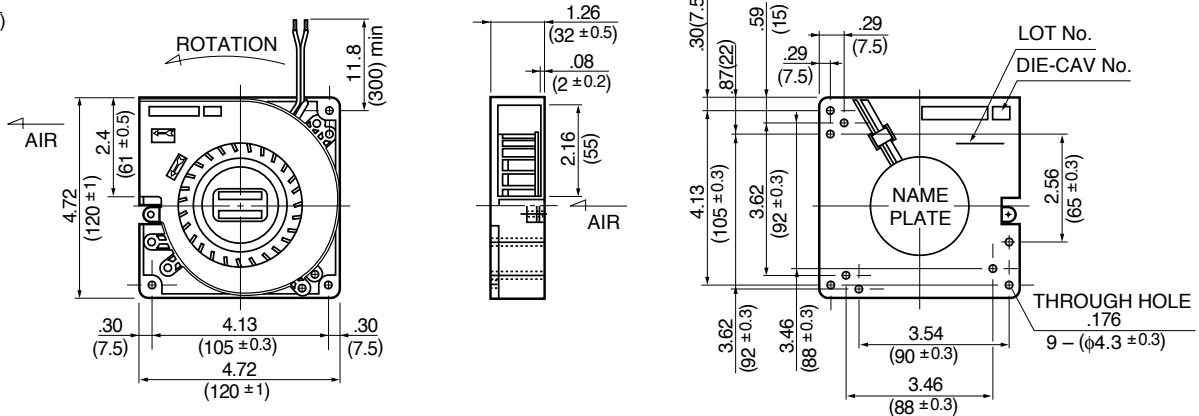
Impeller : Plastic (Black) 94V-0

Bearing : Ball Bearing

Lead Wire : UL1007, AWG26, +Red, -Black

## Outline

Units:  $\frac{\text{inch}}{\text{mm}}$



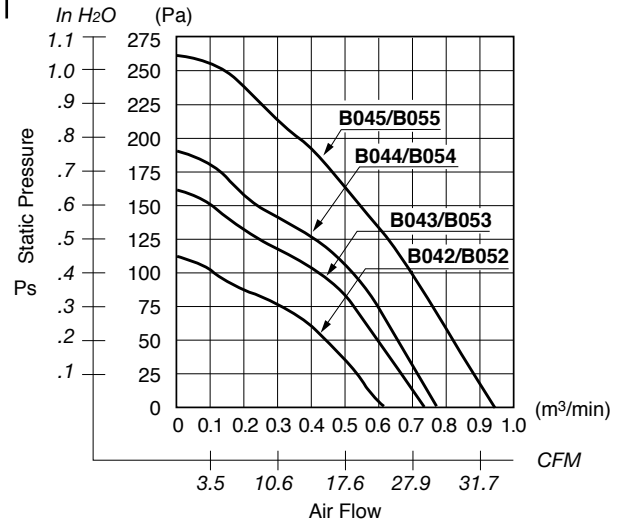
## Specifications

MODEL	Product No.	Rated Voltage	Operating Voltage	Current	Input Power	Speed	Max. Air Flow		Max. Static Pressure		Noise	Mass
		(V)	(V)	(A) <sup>*1</sup>	(W) <sup>*1</sup>	(min <sup>-1</sup> ) <sup>*1</sup>	CFM <sup>*1</sup>	(m <sup>3</sup> /min) <sup>*1</sup>	in H <sub>2</sub> O	(Pa) <sup>*1</sup>	(dB) <sup>*1</sup>	(g)
BG1203-B042-000-	00	12	6 ~ 13.8	0.30	3.60	1800	22.2	0.63	.40	100	41.5	270
BG1203-B043-000-	00	12	6 ~ 13.8	0.48	5.78	2100	26.1	0.74	.58	145	46.5	270
BG1203-B044-000-	00	12	6 ~ 13.8	0.65	7.80	2250	28.2	0.80	.70	175	48.5	270
BG1203-B045-000-	00	12	6 ~ 13.8	0.93	11.16	2650	33.2	0.94	1.04	260	54.0	270
BG1203-B052-000-	00	24	12 ~ 27.6	0.17	4.08	1800	22.2	0.63	.40	100	41.5	270
BG1203-B053-000-	00	24	12 ~ 27.6	0.25	6.00	2100	26.1	0.74	.56	145	46.5	270
BG1203-B054-000-	00	24	12 ~ 27.6	0.30	7.20	2250	28.2	0.80	.70	175	48.5	270
BG1203-B055-000-	00	24	12 ~ 25.2	0.48	11.52	2650	33.2	0.94	1.04	260	54.0	270

Rotation: Counterclockwise

\*1: Average Values in Free Air

## Characteristic Curves



A series of horizontal dotted lines for writing notes.

Notes



## Common Specifications

- Operating Voltage:.....Rated voltage +/- 10%
- Noise: .....Measured at 1 meter from the side of the fan at the rated voltage
- Vibration Test:..... JIS C 60068-2-6
- Shock Test:..... JIS C 60068-2-27
- Insulation Class: ..... E class (UL: Class A)
- Protection: ..... Motor burnout is prevented by the impedance protection system or the thermal protection system.
- Impedance Protection System:..... The motor coil impedance limits motor temperature within the insulation class specification.
- Thermal Protection System: ..... The coil includes a thermal cut-out to limit motor temperature within the insulation class specification.

*Notes:* Additional performance requirements can be determined between manufacturer and customer, based on customer's request. Ball bearing fans may be installed in a horizontal, vertical or angled position.

## Part Numbering System

$\frac{47}{\textcircled{1}}$   $\frac{15}{\textcircled{2}}$   $\frac{P}{\textcircled{3}}$   $\frac{S}{\textcircled{4}}$  -  $\frac{12}{\textcircled{5}}$   $\frac{T}{\textcircled{6}}$  -  $\frac{B}{\textcircled{7}}$   $\frac{2}{\textcircled{8}}$   $\frac{0}{\textcircled{9}}$  -  $\frac{A}{\textcircled{10}}$   $\frac{00}{\textcircled{11}}$

- |  |  |   |  |
|--|--|---|--|
| <p><b>1. Frame Size</b><br/>                 24: 60mm<br/>                 31: 80mm<br/>                 36: 92mm<br/>                 47: 119mm<br/>                 59: 150mm</p> <p><b>2. Frame Thickness</b><br/>                 10: 25mm<br/>                 12: 30mm<br/>                 15: 38mm</p> <p><b>3. Series</b><br/>                 P Series<br/>                 M Series<br/>                 F Series</p> | <p><b>4. Motor Function</b><br/>                 S: Shaded Pole<br/>                 C: Capacitor Run</p> <p><b>5. Input Voltage</b><br/>                 100V Class<br/>                 10: 100V<br/>                 12: 115V<br/>                 200V Class<br/>                 20: 200V<br/>                 22: 220V<br/>                 23: 230V<br/>                 24: 240V</p> | <p><b>6. Termination</b><br/>                 W: Lead Wires<br/>                 T: Terminal</p> <p><b>7. Bearing</b><br/>                 B: Ball Bearing</p> <p><b>8. Speed</b><br/>                 1&lt;2&lt;3&lt;4&lt;5<br/>                 low high</p> <p><b>9. Protection</b><br/>                 0: Impedance Protected<br/>                 A: Thermal Protected<br/>                 (including 5915PC B30 only)</p> | <p><b>10. Product Number</b><br/>                 A: Standard 115V, 230V &amp; 240V<br/>                 B: Standard 100V, 200V &amp; 220V<br/>                 D: Custom Casing 115V-230V<br/>                 K: Frameless</p> <p><b>11. Individual Specification</b><br/>                 00: Standard<br/>                 01~99: Custom</p> |
|--|--|---|--|

$\frac{47}{\textcircled{1}}$   $\frac{15}{\textcircled{2}}$   $\frac{T}{\textcircled{3}}$   $\frac{S}{\textcircled{4}}$  -  $\frac{23}{\textcircled{5}}$   $\frac{T}{\textcircled{6}}$  -  $\frac{B}{\textcircled{7}}$   $\frac{50}{\textcircled{8}}$  -  $\frac{A}{\textcircled{9}}$   $\frac{M}{\textcircled{10}}$   $\frac{0}{\textcircled{11}}$

$\frac{59}{\textcircled{1}}$   $\frac{15}{\textcircled{2}}$   $\frac{P}{\textcircled{3}}$   $\frac{C}{\textcircled{4}}$  -  $\frac{20}{\textcircled{5}}$   $\frac{T}{\textcircled{6}}$  -  $\frac{B}{\textcircled{7}}$   $\frac{30}{\textcircled{8}}$  -  $\frac{S}{\textcircled{9}}$   $\frac{M}{\textcircled{10}}$   $\frac{0}{\textcircled{11}}$

- |  |  |  |   |
|--|--|--|---|
| <p><b>1. Frame Size</b><br/>                 24: 60mm<br/>                 31: 80mm<br/>                 36: 92mm<br/>                 47: 119mm<br/>                 59: 150mm</p> <p><b>2. Frame Thickness</b><br/>                 10: 25mm<br/>                 12: 30mm<br/>                 15: 38mm<br/>                 20: 51mm</p> | <p><b>3. Series</b><br/>                 H: Plastic Blades<br/>                 M: Plastic Blades<br/>                 P: Plastic/Metal Blades<br/>                 T: Metal Blades</p> <p><b>4. Motor Function</b><br/>                 S: Shaded Pole<br/>                 C: Capacitor Run</p> <p><b>5. Input Voltage</b><br/>                 10: 100V<br/>                 12: 115V<br/>                 20: 200V<br/>                 22: 220V<br/>                 23: 230V<br/>                 24: 240V</p> | <p><b>6. Input</b><br/>                 T: Terminal<br/>                 W: Lead Wires</p> <p><b>7. Bearing</b><br/>                 B: Ball Bearing</p> <p><b>8. Speed</b><br/>                 10&lt;20&lt;30&lt;40&lt;50<br/>                 low high<br/>                 X2 Dual Input</p> | <p><b>9. Input Voltage Class</b><br/>                 A: 115V / 230V<br/>                 B: 100V / 200V<br/>                 S: Metal Blades</p> <p><b>10. Potting Method</b><br/>                 M: Potted<br/>                 O: Non-Potted</p> <p><b>11. Product Number</b><br/>                 0: Standard<br/>                 1~: Special</p> |
|--|--|--|---|

## General Specifications

**Motor Structure:** Shaded Pole Induction Motor  
**Motor Protection:** Impedance Protection  
**Insulation Resistance:**  
 10M Ω or over with a DC500V Megger  
**Dielectric Withstand Voltage:** AC 700V 1s  
**Allowable Ambient Temperature Range:**  
 -10°C ~ +70°C (Operating)  
 -40°C ~ +70°C (Storage)  
 (non-condensing environment)

## Expected Life

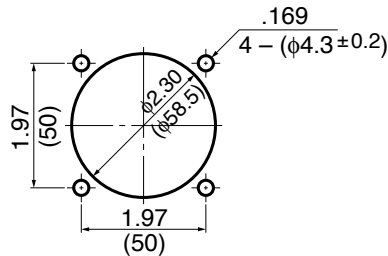
**Failure Rate: 10%**  
 25°C 50,000 Hours

## Material

**Casing :** Aluminum  
**Impeller :** Polycarbonate (Glass Fiber-Containing)  
**Bearing :** Ball Bearing  
**Lead Wire :** UL3266, CSA CL 1252, AWG22

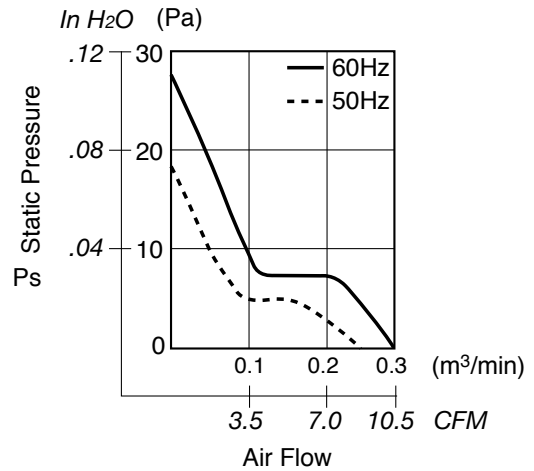
## Panel Cut-Outs

Units:  $\frac{\text{inch}}{\text{mm}}$

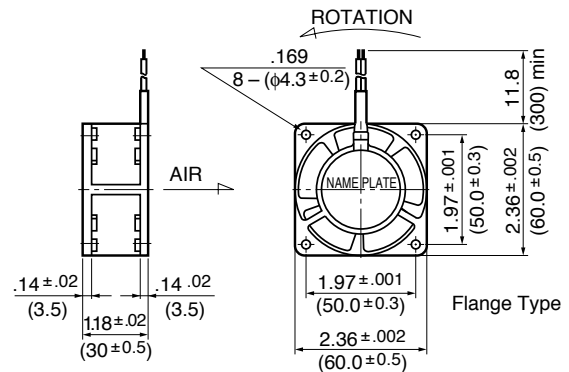


INLET SIDE / OUTLET SIDE

## Characteristic Curves



## Outline



## Specifications

MODEL	Rated Voltage	Frequency	Starting Voltage	Current	Input Power	Speed	Max. Air Flow		Max. Static Pressure		Noise	Mass
	(V)	(Hz)	(V)	(A) <sup>*1</sup>	(W) <sup>*10%</sup> <sup>-20%</sup>	(min <sup>-1</sup> ) <sup>*2</sup>	CFM	(m <sup>3</sup> /min) <sup>*2</sup>	in H <sub>2</sub> O	(Pa) <sup>*2</sup>	(dB) <sup>*2</sup>	(g)
2412PS-10W-B30-A00	100	50	65	0.080	6.0	2000	7.0	0.20	.05	13.7	28	140
	100	60	65	0.070	5.0	2600	9.1	0.26	.09	22.6	29	140
2412PS-12W-B30-A00	115	50	65	0.070	4.5	2000	7.0	0.20	.05	13.7	28	140
	115	60	65	0.060	4.0	2600	9.1	0.26	.09	22.6	29	140

Rotation: Counterclockwise

Airflow Outlet: Air out over struts

\*1: Maximum Values in Free Air

\*2: Average Values in Free Air

\*3: Minimum Values in Free Air

### General Specifications

**Motor Structure:** Shaded Pole Induction Motor  
**Motor Protection:** Impedance Protection  
**Insulation Resistance:**  
 10M Ω or over with a DC500V Megger  
**Dielectric Withstand Voltage:** AC 700V 1s  
**Allowable Ambient Temperature Range:**  
 -10°C ~ +70°C (Operating)  
 -40°C ~ +70°C (Storage)  
 (non-condensing environment)

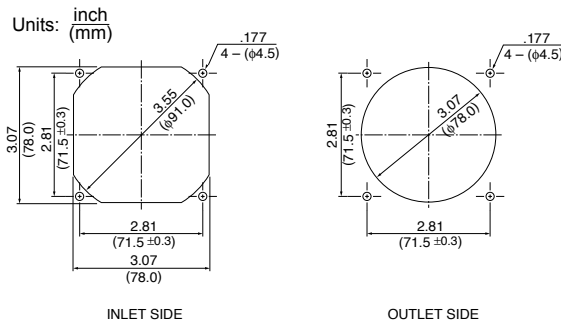
### Expected Life

**Failure Rate: 10%**  
 25°C 100,000 Hours

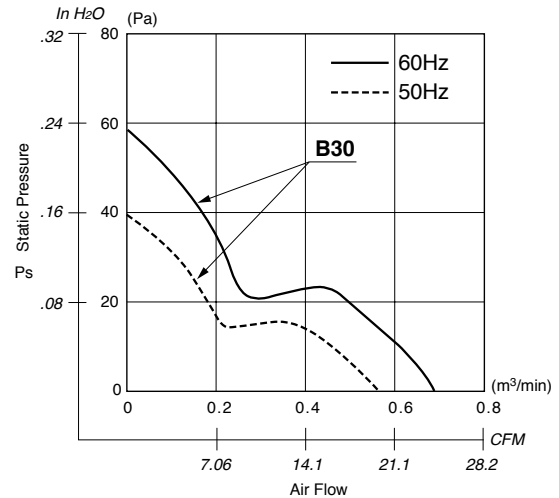
### Material

**Casing :** Aluminum  
**Impeller :** Polycarbonate (Glass Fiber-Containing)  
**Bearing :** Ball Bearing  
**Lead Wire :** UL3266, CSA CL 1252, AWG22

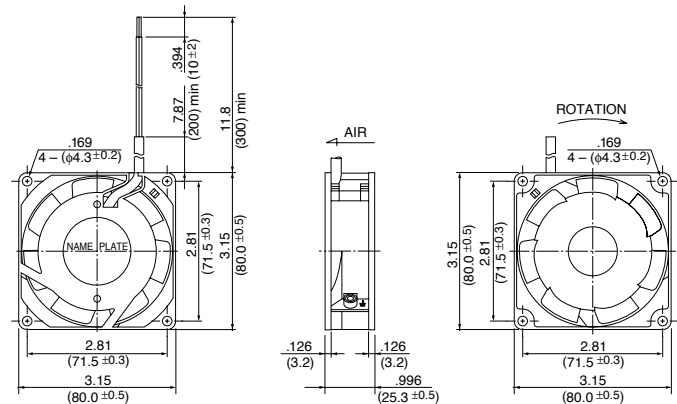
### Panel Cut-Outs



### Characteristic Curves



### Outline



### Specifications

MODEL	Rated Voltage	Frequency	Starting Voltage	Current	Input Power	Speed	Max. Air Flow		Max. Static Pressure		Noise	Mass
	(V)	(Hz)	(V)	(A) <sup>*1</sup>	(W) <sup>*1</sup>	(min <sup>-1</sup> ) <sup>*1</sup>	CFM	(m <sup>3</sup> /min) <sup>*1</sup>	in H <sub>2</sub> O	(Pa) <sup>*1</sup>	(dB) <sup>*1</sup>	(g)
** 3110MS-20W-B30-B00	200	50	130	0.060	7.0	2500	20.1	0.57	0.15	39.0	24	240
** 3110MS-20W-B30-B00	200	60	130	0.050	6.0	3000	24.0	0.68	0.22	55.0	31	240
** 3110MS-22W-B30-B00	220	50	165	0.055	7.5	2500	20.1	0.57	0.15	39.0	24	240
** 3110MS-22W-B30-B00	220	60	165	0.045	6.5	3000	24.0	0.68	0.22	55.0	31	240
3110MS-23W-B30-A00	230	50	180	0.050	7.5	2500	20.1	0.57	0.15	39.0	24	240
3110MS-23W-B30-A00	230	60	180	0.045	6.5	3000	24.0	0.68	0.22	55.0	31	240
** 3110MS-24W-B30-A00	240	50	180	0.050	7.5	2500	20.1	0.57	0.15	39.0	24	240
** 3110MS-24W-B30-A00	240	60	180	0.045	6.5	3000	24.0	0.68	0.22	55.0	31	240

Rotation: Counterclockwise

Airflow Outlet: Air Out Over Struts

\*1: Maximum Values in Free Air

\*\* Contact NMB for Availability

\*2: Average Values in Free Air

\*3: Minimum Values in Free Air

## General Specifications

**Motor Structure:** Shaded Pole Induction Motor  
**Motor Protection:** Impedance Protection  
**Insulation Resistance:**  
 10M Ω or over with a DC500V Megger  
**Dielectric Withstand Voltage:** AC 700V 1s  
**Allowable Ambient Temperature Range:**  
 -10°C ~ +70°C (Operating)  
 -40°C ~ +70°C (Storage)  
 (non-condensing environment)

## Expected Life

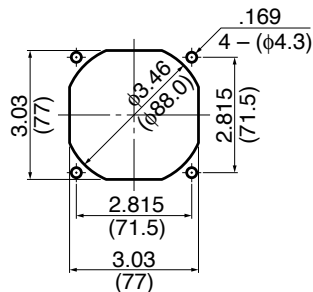
**Failure Rate: 10%**  
 25°C 50,000 Hours

## Material

**Casing :** Aluminum  
**Impeller :** Polycarbonate (Glass Fiber-Containing)  
**Bearing :** Ball Bearing  
**Lead Wire :** UL3266, CSA CL 1252, AWG22

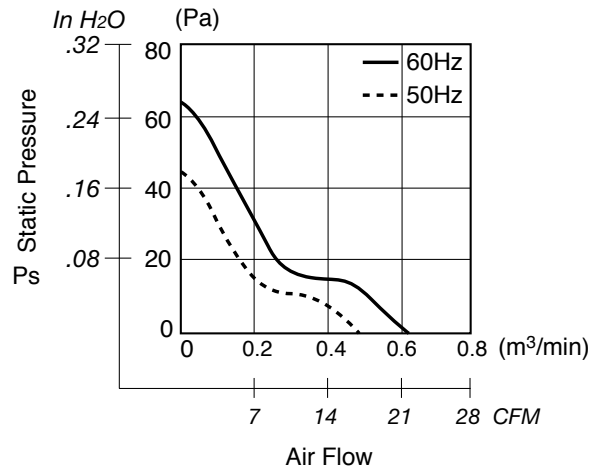
## Panel Cut-Outs

Units:  $\frac{\text{inch}}{\text{mm}}$

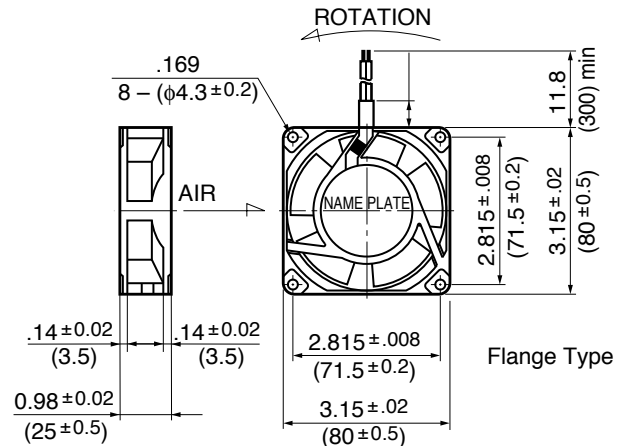


INLET SIDE / OUTLET SIDE

## Characteristic Curves



## Outline



## Specifications

MODEL	Rated Voltage	Frequency	Starting Voltage	Current	Input Power	Speed	Max. Air Flow		Max. Static Pressure		Noise	Mass
	(V)	(Hz)	(V)	(A) <sup>1</sup>	(W) <sup>10% 20%</sup>	(min <sup>-1</sup> ) <sup>3</sup>	CFM	(m <sup>3</sup> /min) <sup>3</sup>	in H <sub>2</sub> O	(Pa) <sup>3</sup>	(dB) <sup>2</sup>	(g)
3110PS-10W-B30-A00	100	50	65	0.090	6.0	2600	16.2	0.46	.15	39.2	28	220
	100	60	65	0.080	5.0	3100	19.7	0.56	.21	53.9	33	220
3110PS-12W-B30-A00	115	50	65	0.085	6.0	2600	16.2	0.46	.15	39.2	28	220
	115	60	65	0.075	5.0	3100	19.7	0.56	.21	53.9	33	220

Rotation: Counterclockwise

Airflow Outlet: Air Out Over Struts

\*1: Maximum Values in Free Air

\*2: Average Values in Free Air

\*3: Minimum Values in Free Air

## General Specifications

**Motor Structure:** Shaded Pole Induction Motor  
**Motor Protection:** Impedance Protection  
**Insulation Resistance:**  
 10M Ω or over with a DC500V Megger  
**Dielectric Withstand Voltage:** AC 700V 1s  
**Allowable Ambient Temperature Range:**  
 -10°C ~ +70°C (Operating)  
 -40°C ~ +70°C (Storage)  
 (non-condensing environment)

## Expected Life

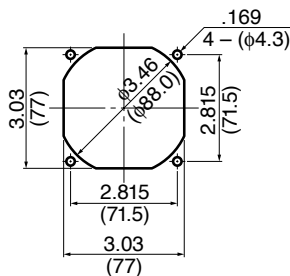
**Failure Rate: 10%**  
 25°C 50,000 Hours

## Material

**Casing** : Aluminum  
**Impeller** : UL94V-O Reinforced Plastic  
**Bearing** : Ball Bearing  
**Lead Wire** : AWG22, UL3266, CSA CL1252  
**or Terminal** : Faston #110 or equivalent

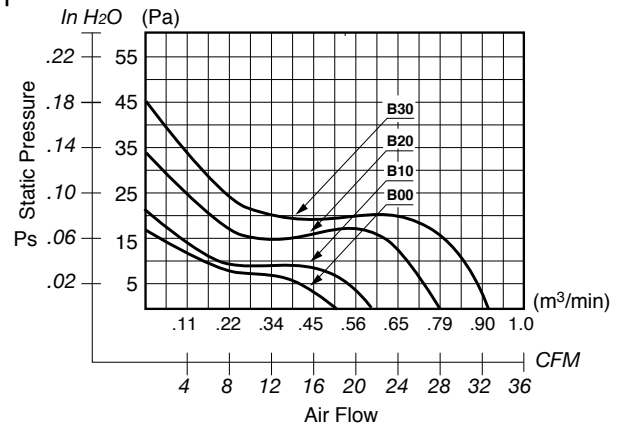
## Panel Cut-Outs

Units:  $\frac{\text{inch}}{\text{mm}}$

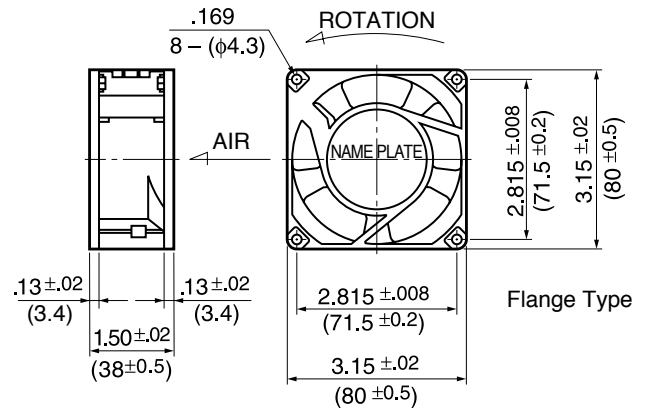


INLET SIDE / OUTLET SIDE

## Characteristic Curves



## Outline



## Specifications

MODEL	Rated Voltage	Frequency	Starting Voltage	Current	Input Power	Speed	Max. Air Flow		Max. Static Pressure		Noise	Mass
	(V)	(Hz)	(V)	(A) <sup>*1</sup>	(W) <sup>*1</sup>	(min <sup>-1</sup> ) <sup>*1</sup>	CFM	(m <sup>3</sup> /min) <sup>*1</sup>	in H <sub>2</sub> O	(Pa) <sup>*1</sup>	(dB) <sup>*1</sup>	(g)
3115FS-12T-B00-A00	115	60	75	0.045	4.0	1850	18.0	0.51	.07	17.5	31	340
3115FS-12T-B10-A00	115	60	75	0.087	6.5	2100	22.0	0.62	.09	22.5	36	340
3115FS-12T-B20-A00	115	60	75	0.090	7.5	2700	27.0	0.76	.13	32.5	40	340
3115FS-12T-B30-A00	115	60	75	0.100	8.5	3250	32.0	0.90	.18	45.0	44	340
3115FS-23T-B10-A00	230	60	175	0.050	6.5	2050	20.0	0.57	.09	22.5	35	340
3115FS-23T-B20-A00	230	60	175	0.060	7.5	2750	28.0	0.79	.13	32.5	40	340
3115FS-23T-B30-A00	230	60	175	0.065	8.0	3250	33.0	0.93	.18	45.0	44	340

Rotation: Counterclockwise

Airflow Outlet: Air In Over Struts

\*1: Maximum Values in Free Air

\*2: Average Values in Free Air

\*3: Minimum Values in Free Air

### General Specifications

Motor Structure: Shaded Pole Induction Motor  
 Motor Protection: Impedance Protection  
 Insulation Resistance:  
 10M Ω or over with a DC500V Megger  
 Dielectric Withstand Voltage: AC 700V 1s  
 Allowable Ambient Temperature Range:  
 -10°C ~ +70°C (Operating)  
 -40°C ~ +70°C (Storage)  
 (non-condensing environment)

### Expected Life

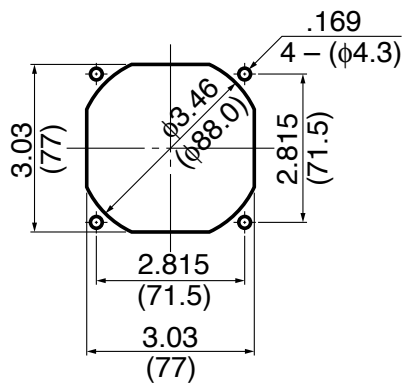
Failure Rate: 10%  
 25°C 50,000 Hours

### Material

Casing : Aluminum  
 Impeller : Polycarbonate  
 (Glass Fiber-Containing)  
 Bearing : Ball Bearing  
 Lead Wire : AWG22, UL3266, CSA CL1252  
 or Terminal : Faston #110 or equivalent

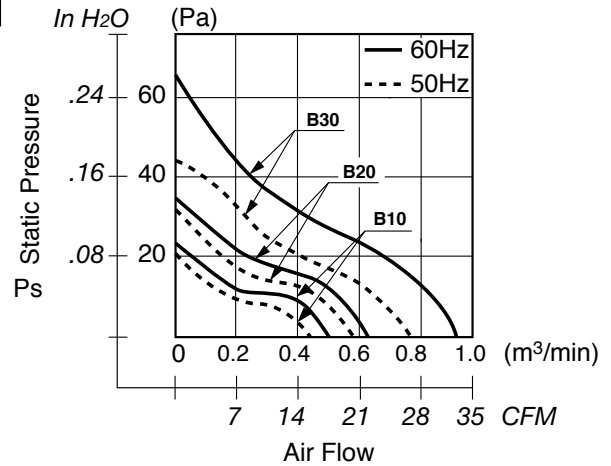
### Panel Cut-Outs

Units:  $\frac{\text{inch}}{\text{mm}}$

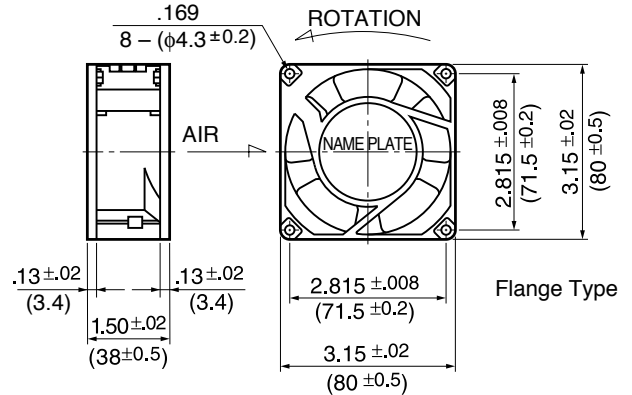


INLET SIDE / OUTLET SIDE

### Characteristic Curves



### Outline



## Specifications

MODEL	Rated Voltage	Frequency	Starting Voltage	Current	Input Power	Speed	Max. Air Flow		Max. Static Pressure		Noise	Mass
	(V)	(Hz)	(V)	(A) <sup>1</sup>	(W) <sup>+10% -20%</sup>	(min <sup>-1</sup> ) <sup>3</sup>	CFM	(m <sup>3</sup> /min) <sup>3</sup>	in H <sub>2</sub> O	(Pa) <sup>3</sup>	(dB) <sup>2</sup>	(g)
** 3115PS-10T-B30-B00	100	50	65	0.170	9.0	2700	26.5	0.75	.14	34.3	33.0	270
	100	60	65	0.120	7.0	3200	32.0	0.90	.20	49.0	38.0	270
3115PS-12T-B30-A00	115	50	75	0.140	9.0	2700	26.5	0.75	.14	34.3	33.0	270
	115	60	75	0.110	7.0	3200	32.0	0.90	.20	49.0	38.0	270
** 3115PS-20T-B30-B00	200	50	130	0.080	9.0	2700	26.5	0.75	.14	34.3	33.0	270
	200	60	130	0.060	7.0	3200	32.0	0.90	.20	49.0	38.0	270
** 3115PS-22T-B30-B00	220	50	150	0.070	9.0	2700	26.5	0.75	.14	34.3	33.0	270
	220	60	150	0.060	7.0	3200	32.0	0.90	.20	49.0	38.0	270
3115PS-23T-B30-A00	230	50	150	0.070	10.0	2700	26.5	0.75	.14	34.3	33.0	270
	230	60	150	0.055	8.0	3200	32.0	0.90	.20	49.0	38.0	270
** 3115PS-24T-B30-A00	240	50	150	0.075	12.0	2700	26.5	0.75	.14	34.3	33.0	270
	240	60	150	0.060	9.0	3200	32.0	0.90	.20	49.0	38.0	270
** 3115PS-10T-B20-B00	100	50	65	0.080	4.5	2100	21.0	0.60	.10	24.5	29.0	270
	100	60	65	0.070	4.0	2300	24.0	0.68	.12	29.4	32.0	270
3115PS-12T-B20-A00	115	50	75	0.080	5.0	2100	21.0	0.60	.10	24.5	29.0	270
	115	60	75	0.070	4.5	2300	24.0	0.68	.12	29.4	32.0	270
** 3115PS-20T-B20-B00	200	50	130	0.040	4.5	2100	21.0	0.60	.10	24.5	29.0	270
	200	60	160	0.035	4.0	2300	24.0	0.68	.13	31.3	32.0	270
** 3115PS-22T-B20-B00	220	50	165	0.045	6.0	2200	22.0	0.63	.10	24.5	29.0	270
	220	60	165	0.040	5.0	2400	25.4	0.72	.13	31.3	34.0	270
3115PS-23T-B20-A00	230	50	150	0.050	7.0	2200	22.0	0.63	.10	24.5	30.0	270
	230	60	150	0.045	6.0	2500	26.0	0.74	.14	35.2	34.0	270
** 3115PS-24T-B20-A00	240	50	150	0.055	7.0	2200	22.0	0.63	.10	24.5	30.0	270
	240	60	150	0.045	6.0	2600	26.5	0.75	.15	37.2	35.0	270
** 3115PS-10T-B10-B00	100	50	65	0.065	4.5	1700	17.6	0.50	.06	16.6	23.0	270
	100	60	65	0.055	4.0	1900	19.4	0.55	.08	21.5	25.0	270
3115PS-12T-B10-A00	115	50	75	0.060	4.5	1700	17.6	0.50	.06	16.6	23.0	270
	115	60	75	0.055	4.0	1900	19.4	0.55	.08	21.5	25.0	270
** 3115PS-20T-B10-B00	200	50	130	0.045	4.5	1700	17.6	0.50	.06	16.6	23.0	270
	200	60	160	0.040	4.0	1900	19.4	0.55	.08	21.5	26.0	270
** 3115PS-22T-B10-B00	220	50	150	0.050	5.5	1750	17.6	0.50	.06	16.6	23.0	270
	220	60	150	0.045	4.5	2000	21.2	0.60	.09	23.5	26.0	270
3115PS-23T-B10-A00	230	50	150	0.055	6.0	1800	17.6	0.50	.07	17.6	23.0	270
	230	60	150	0.050	5.0	2100	22.0	0.63	.10	24.5	26.0	270
** 3115PS-24T-B10-A00	240	50	150	0.060	7.0	1800	17.6	0.50	.07	17.6	23.0	270
	240	60	150	0.055	6.0	2150	21.6	0.64	.10	25.4	26.0	270

Rotation: Counterclockwise

Airflow Outlet: Air Out Over Struts

\*1: Maximum Values in Free Air

\*\* Contact NMB for Availability

\*2: Average Values in Free Air

\*3: Minimum Values in Free Air

**General Specifications**

**Motor Structure:** Shaded Pole Induction Motor  
**Motor Protection:** Impedance Protection  
**Insulation Resistance:**  
 10M Ω or over with a DC500V Megger  
**Dielectric Withstand Voltage:** AC 700V 1s  
**Allowable Ambient Temperature Range:**  
 -10°C ~ +70°C (Operating)  
 -40°C ~ +70°C (Storage)  
 (non-condensing environment)

**Expected Life**

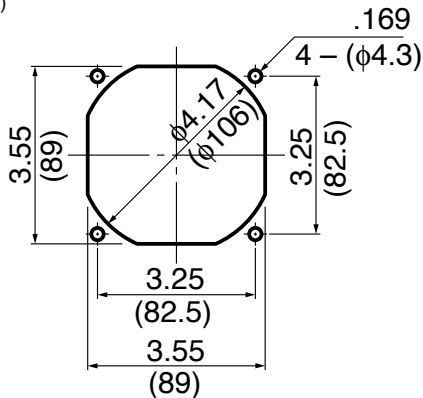
**Failure Rate: 10%**  
 25°C 50,000 Hours

**Material**

Casing : Aluminum  
 Impeller : Polycarbonate  
 (Glass Fiber-Containing)  
 Bearing : Ball Bearing  
 Lead Wire : AWG22, UL3266, CSA CL1252  
 or Terminal : Faston #110 or equivalent

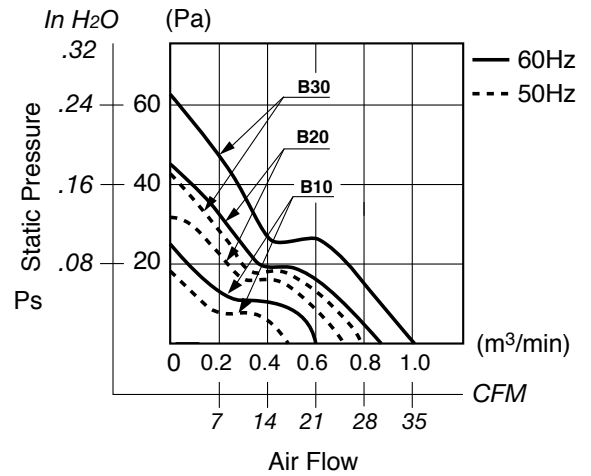
**Panel Cut-Outs**

Units:  $\frac{\text{inch}}{\text{mm}}$

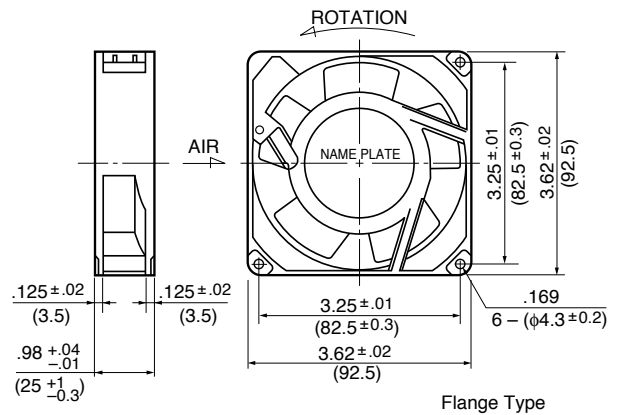


INLET SIDE / OUTLET SIDE

**Characteristic Curves**



**Outline**



Flange Type



## Specifications

MODEL	Rated Voltage	Frequency	Starting Voltage	Current	Input Power	Speed	Max. Air Flow		Max. Static Pressure		Noise	Mass
	(V)	(Hz)	(V)	(A) <sup>*1</sup>	(W) <sup>+10% -20%</sup>	(min <sup>-1</sup> ) <sup>*3</sup>	CFM	(m <sup>3</sup> /min) <sup>*3</sup>	in H <sub>2</sub> O	(Pa) <sup>*3</sup>	(dB) <sup>*2</sup>	(g)
** 3610PS-10T-B30-B00	100	50	65	0.190	13.0	2600	28.0	0.80	.17	43.1	33.5	300
	100	60	65	0.150	10.0	3100	34.5	0.98	.24	60.7	38.0	300
3610PS-12T-B30-A00	115	50	75	0.170	12.0	2600	28.0	0.80	.17	43.1	33.5	300
	115	60	75	0.130	9.0	3100	34.5	0.98	.24	60.7	38.0	300
** 3610PS-20T-B30-B00	200	50	130	0.100	13.0	2600	28.0	0.80	.17	43.1	33.5	300
	200	60	130	0.080	10.0	3100	34.5	0.98	.24	60.7	38.0	300
** 3610PS-22T-B30-B00	220	50	165	0.100	13.0	2600	28.0	0.80	.17	43.1	34.0	300
	220	60	165	0.080	10.0	3100	34.5	0.98	.24	60.7	39.0	300
3610PS-23T-B30-A00	230	50	180	0.090	13.0	2600	28.0	0.80	.17	43.1	34.0	300
	230	60	180	0.070	10.0	3100	34.5	0.98	.24	60.7	39.0	300
** 3610PS-24T-B30-A00	240	50	180	0.085	13.0	2600	28.0	0.80	.17	43.1	34.0	300
	240	60	180	0.065	10.0	3100	34.5	0.98	.24	60.7	39.0	300
** 3610PS-10T-B20-B00	100	50	65	0.095	7.0	2100	21.0	0.60	.11	27.4	30.0	300
	100	60	65	0.085	6.0	2500	28.0	0.80	.16	39.2	35.0	300
3610PS-12T-B20-A00	115	50	75	0.095	7.0	2100	21.0	0.60	.12	29.4	30.0	300
	115	60	75	0.090	6.0	2500	28.0	0.80	.16	39.2	35.0	300
** 3610PS-20T-B20-B00	200	50	130	0.060	7.0	2100	22.9	0.65	.11	27.4	30.0	300
	200	60	160	0.050	6.0	2500	28.0	0.80	.16	39.0	35.0	300
** 3610PS-22T-B20-B00	220	50	165	0.050	6.5	2100	21.0	0.60	.12	29.4	30.0	300
	220	60	165	0.050	5.5	2500	28.0	0.80	.15	38.2	35.0	300
3610PS-23T-B20-A00	230	50	180	0.050	7.0	2100	21.0	0.60	.12	29.4	30.0	300
	230	60	180	0.050	6.0	2500	28.0	0.80	.16	39.2	35.0	300
** 3610PS-24T-B20-A00	240	50	180	0.050	9.0	2100	21.0	0.60	.12	29.4	30.0	300
	240	60	180	0.050	8.0	2500	28.0	0.80	.16	39.2	35.0	300
** 3610PS-10T-B10-B00	100	50	65	0.100	7.0	1450	16.0	0.46	.05	13.7	23.0	300
	100	60	65	0.090	6.0	1800	20.0	0.58	.08	19.6	26.0	300
3610PS-12T-B10-A00	115	50	75	0.090	7.0	1450	16.0	0.46	.05	13.7	22.0	300
	115	60	75	0.080	6.0	1800	20.0	0.58	.08	19.6	25.0	300
** 3610PS-20T-B10-B00	200	50	130	0.045	7.0	1500	16.0	0.46	.05	13.7	24.0	300
	200	60	130	0.040	6.0	1900	21.0	0.60	.08	19.6	27.0	300
** 3610PS-22T-B10-B00	220	50	165	0.050	8.0	1450	16.0	0.46	.05	13.7	23.0	300
	220	60	165	0.040	7.0	1800	21.0	0.60	.08	19.6	26.0	300
3610PS-23T-B10-A00	230	50	180	0.050	7.0	1450	16.0	0.46	.05	13.7	22.0	300
	230	60	180	0.040	6.0	1800	20.0	0.58	.08	19.6	26.0	300
** 3610PS-24T-B10-A00	240	50	180	0.050	8.0	1450	16.0	0.46	.05	13.7	24.0	300
	240	60	180	0.045	7.0	1800	21.0	0.60	.08	19.6	27.0	300

Rotation: Counterclockwise  
 \*\* Contact NMB for Availability

Airflow Outlet: Air Out Over Struts

\*1: Maximum Values in Free Air  
 \*2: Average Values in Free Air  
 \*3: Minimum Values in Free Air

**General Specifications**

Motor Structure: Shaded Pole Induction Motor  
 Motor Protection: Impedance Protection  
 Insulation Resistance:  
 10M Ω or over with a DC500V Megger  
 Dielectric Withstand Voltage: AC 700V 1s  
 Allowable Ambient Temperature Range:  
 -10°C ~ +70°C (Operating)  
 -40°C ~ +70°C (Storage)

**Expected Life**

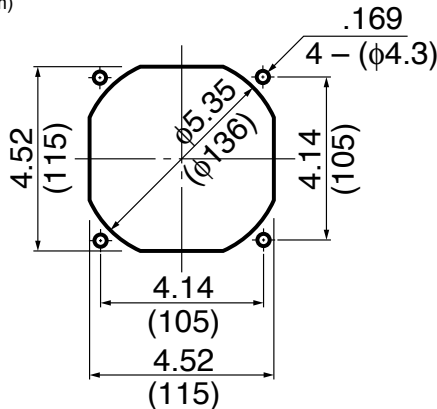
Failure Rate: 10%  
 25°C 50,000 Hours

**Material**

Casing : Aluminum  
 Impeller : Polycarbonate (Glass Fiber-Containing)  
 Bearing : Ball Bearing  
 Terminal : Faston #110 or equivalent

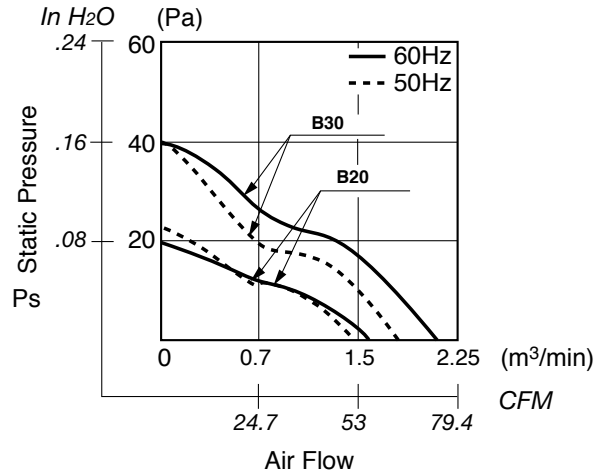
**Panel Cut-Outs**

Units:  $\frac{\text{inch}}{\text{mm}}$

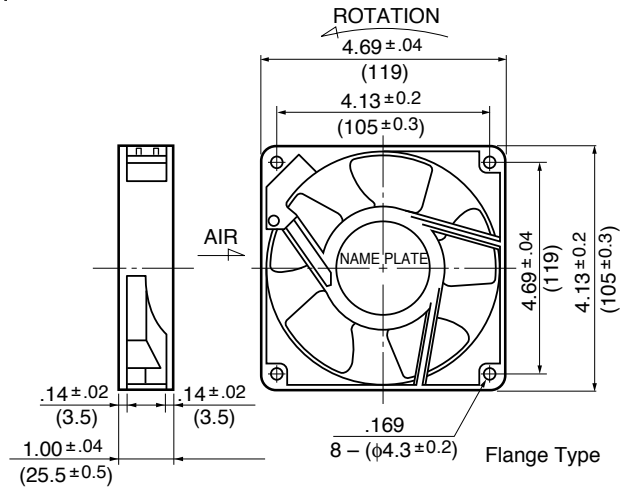


INLET SIDE / OUTLET SIDE

**Characteristic Curves**



**Outline**



## Specifications

MODEL	Rated Voltage	Frequency	Starting Voltage	Current	Input Power	Speed	Max. Air Flow		Max. Static Pressure		Noise	Mass
	(V)	(Hz)	(V)	(A) <sup>1</sup>	(W) <sup>+10% -20%</sup>	(min <sup>-1</sup> ) <sup>3</sup>	CFM	(m <sup>3</sup> /min) <sup>3</sup>	in H <sub>2</sub> O	(Pa) <sup>3</sup>	(dB) <sup>2</sup>	(g)
** 4710PS-10T-B30-B00	100	50	65	0.220	14.0	2300	63.5	1.80	.16	41.1	34.0	360
	100	60	65	0.180	11.0	2700	70.6	2.00	.16	41.1	38.0	360
4710PS-12T-B30-A00	115	50	75	0.190	14.0	2300	63.5	1.80	.16	41.1	34.0	360
	115	60	75	0.160	11.0	2700	70.6	2.00	.16	41.1	38.0	360
** 4710PS-20T-B30-B00	200	50	130	0.110	14.0	2300	63.5	1.80	.16	41.1	34.0	360
	200	60	130	0.090	11.0	2700	70.6	2.00	.16	41.1	38.0	360
** 4710PS-22T-B30-B00	220	50	175	0.100	14.0	2300	63.5	1.80	.16	41.1	34.0	360
	220	60	175	0.080	11.0	2700	70.6	2.00	.16	41.1	38.0	360
4710PS-23T-B30-A00	230	50	175	0.100	14.0	2300	63.5	1.80	.16	41.1	34.0	360
	230	60	175	0.090	11.0	2700	70.6	2.00	.16	41.1	38.0	360
** 4710PS-24T-B30-A00	240	50	130	0.100	15.0	2300	60.0	1.70	.16	41.1	34.0	360
	240	60	130	0.080	13.0	2700	70.6	2.00	.16	41.1	38.0	360
** 4710PS-10T-B20-B00	100	50	65	0.120	8.0	1900	49.4	1.40	.08	19.6	29.0	360
	100	60	65	0.100	7.0	2100	53.0	1.50	.086	21.5	30.0	360
4710PS-12T-B20-A00	115	50	75	0.100	8.0	1900	49.4	1.40	.09	23.5	29.0	360
	115	60	75	0.090	7.0	2000	53.0	1.50	.08	21.5	30.0	360
** 4710PS-20T-B20-B00	200	50	130	0.070	9.0	1900	45.9	1.30	.08	19.6	29.0	360
	200	60	160	0.060	8.0	2000	53.0	1.50	.086	21.5	30.0	360
** 4710PS-22T-B20-B00	220	50	175	0.060	9.0	1900	49.4	1.40	.08	19.6	29.0	360
	220	60	175	0.050	8.0	2100	53.0	1.50	.086	21.5	30.0	360
** 4710PS-23T-B20-A00	230	50	175	0.060	9.0	1900	49.4	1.40	.09	23.5	29.0	360
	230	60	175	0.050	8.0	2100	53.0	1.50	.08	21.5	30.0	360
4710PS-24T-B20-A00	240	50	140	0.060	9.0	1900	49.4	1.40	.08	19.6	29.0	360
	240	60	140	0.050	8.0	2100	53.0	1.50	.086	21.5	30.0	360

Rotation: Counterclockwise  
 \*\* Contact NMB for Availability

Airflow Outlet: Air Out Over Struts

\*1: Maximum Values in Free Air  
 \*2: Average Values in Free Air  
 \*3: Minimum Values in Free Air

## General Specifications

**Motor Structure:** Shaded Pole Induction Motor  
**Motor Protection:** Impedance Protection  
**Insulation Resistance:**  
 10M Ω or over with a DC500V Megger  
**Dielectric Withstand Voltage:** AC 700V 1s  
**Allowable Ambient Temperature Range:**  
 -10°C ~ +70°C (Operating)  
 -40°C ~ +70°C (Storage)  
 (non-condensing environment)

## Expected Life

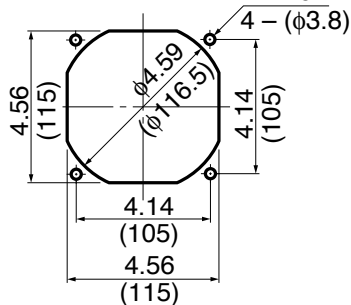
**Failure Rate: 10%**  
 25°C 100,000 Hours (D00)

## Material

**Casing** : Aluminum Alloy  
**Impeller** : UL94V-O Reinforced Plastic  
**Bearing** : Ball Bearing  
**Lead Wire** : AWG22, UL3266, CSA CL1252  
**or Terminal** : Faston #110 or equivalent

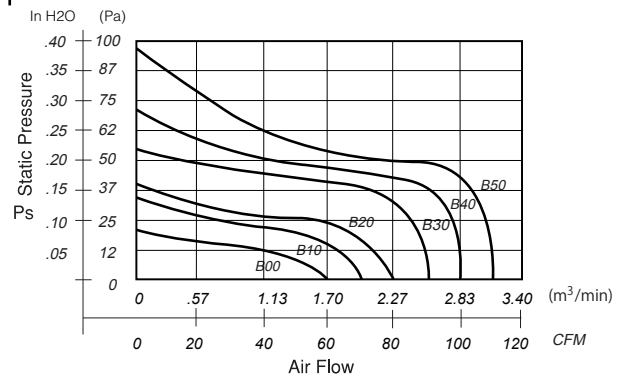
## Panel Cut-Outs

Units:  $\frac{\text{inch}}{\text{(mm)}}$

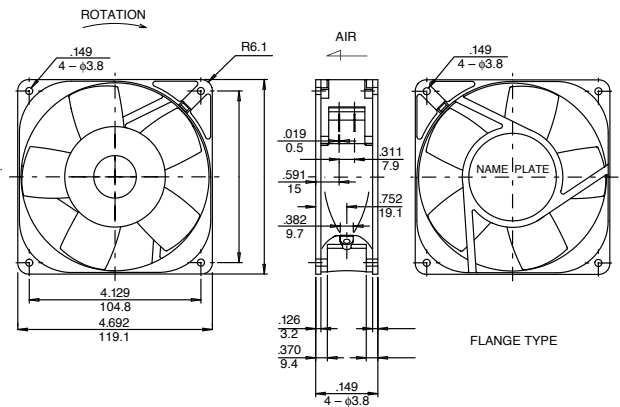


INLET SIDE / OUTLET SIDE

## Characteristic Curves



## Outline



## Specifications

MODEL	Rated Voltage	Frequency	Starting Voltage	Current	Input Power	Speed	Max. Air Flow		Max. Static Pressure		Noise	Mass
	(V)	(Hz)	(V)	(A) <sup>*1</sup>	(W) <sup>*1</sup>	(min <sup>-1</sup> ) <sup>*1</sup>	CFM	(m <sup>3</sup> /min) <sup>*1</sup>	in H <sub>2</sub> O	(Pa) <sup>*1</sup>	(dB) <sup>*1</sup>	(g)
4715FS-12T-B00-D00	115	60	75	0.090	7.5	1700	60.0	1.70	.08	20.0	31	550
4715FS-12T-B10-D00	115	60	75	0.110	10.0	1900	70.0	1.98	.12	30.0	33	550
4715FS-12T-B20-D00	115	60	75	0.100	9.8	2300	80.0	2.25	.13	32.5	36	550
4715FS-12T-B30-D00	115	60	75	0.180	14.5	2650	90.0	2.50	.22	55.0	39	550
4715FS-12T-B40-D00	115	60	75	0.170	14.0	2800	100.0	2.80	.29	72.5	42	550
4715FS-12T-B50-D00	115	60	75	0.190	14.4	3100	110.0	3.10	.37	92.5	45	550
4715FS-23T-B00-D00	230	60	175	0.030	5.5	1600	55.0	1.50	.07	17.5	31	550
4715FS-23T-B10-D00	230	60	175	0.050	9.0	1900	70.0	1.98	.12	30.0	33	550
4715FS-23T-B20-D00	230	60	175	0.050	8.8	2300	80.0	2.25	.13	32.5	36	550
4715FS-23T-B30-D00	230	60	175	0.090	12.0	2650	90.0	2.50	.22	55.0	39	550
4715FS-23T-B40-D00	230	60	175	0.090	14.0	2800	100.0	2.80	.28	70.0	42	550
4715FS-23T-B50-D00	230	60	175	0.080	14.0	3100	110.0	3.10	.37	92.5	45	550

Rotation: Counterclockwise

Airflow Outlet: Air In Over Struts

\*1: Maximum Values in Free Air

\*2: Average Values in Free Air

\*3: Minimum Values in Free Air

### General Specifications

**Motor Structure:** Shaded Pole Induction Motor  
**Motor Protection:** Impedance Protection  
**Insulation Resistance:**  
 10M Ω or over with a DC500V Megger  
**Dielectric Withstand Voltage:** AC 700V 1s  
**Allowable Ambient Temperature Range:**  
 -10°C ~ +65°C (Operating)  
 -40°C ~ +70°C (Storage)  
 (non-condensing environment)

### Expected Life

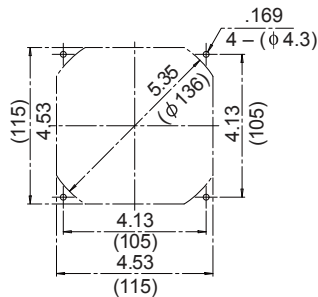
**Failure Rate: 10%**  
 25°C 100,000 Hours

### Material

**Casing :** Aluminum  
**Impeller :** Polybutylene terephthalate  
 (Glass Fiber-Containing)  
**Bearing :** Ball Bearings  
**Lead Wire :** Faston #110 or Equivalent

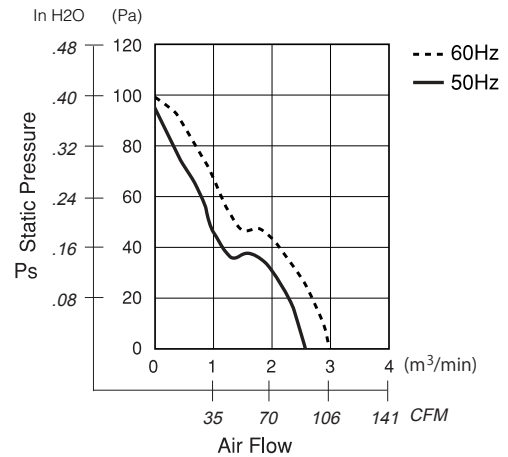
### Panel Cut-Outs

Units: inch (mm)

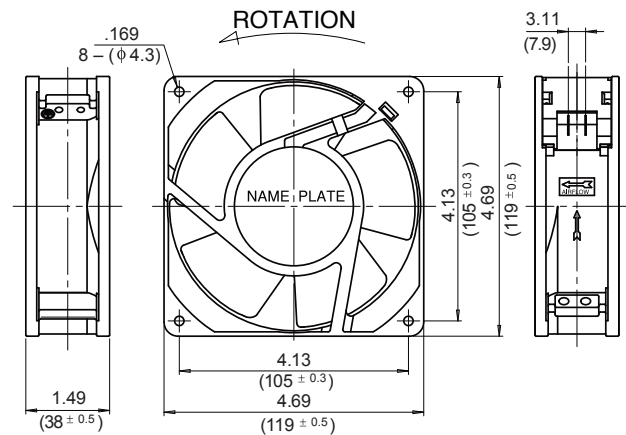


INLET SIDE / OUTLET SIDE

### Characteristic Curves



### Outline



### Specifications

MODEL	Rated Voltage	Frequency	Starting Voltage	Current	Input Power	Speed	Max. Air Flow		Max. Static Pressure		Noise	Mass
	(V)	(Hz)	(V)	(A) <sup>1</sup>	(W)	(min <sup>-1</sup> ) <sup>3</sup>	CFM	(m <sup>3</sup> /min) <sup>2</sup>	in H <sub>2</sub> O	(Pa) <sup>2</sup>	(dB) <sup>2</sup>	(g)
** 4715HS-10T-B5A-B00	100	50	65	0.370	18.0	2600	91.8	2.60	0.380	94.0	40	570
** 4715HS-10T-B5A-B00	100	60	65	0.290	15.5	3100	105.9	3.00	0.400	100.0	44	570
** 4715HS-12T-B5A-A00	115	50	75	0.320	18.0	2600	91.8	2.60	0.380	94.0	40	570
** 4715HS-12T-B5A-A00	115	60	75	0.250	15.5	3100	105.9	3.00	0.400	100.0	44	570
** 4715HS-20T-B5A-B00	200	50	130	0.180	18.0	2600	91.8	2.60	0.380	94.0	40	570
** 4715HS-20T-B5A-B00	200	60	130	0.150	15.5	3100	105.9	3.00	0.400	100.0	44	570
** 4715HS-22T-B5A-B00	220	50	145	0.160	18.0	2600	91.8	2.60	0.380	94.0	40	570
** 4715HS-22T-B5A-B00	220	60	145	0.130	15.5	3100	105.9	3.00	0.400	100.0	44	570
** 4715HS-23T-B5A-A00	230	50	175	0.160	18.0	2600	91.8	2.60	0.380	94.0	40	570
** 4715HS-23T-B5A-A00	230	60	175	0.120	15.5	3100	105.9	3.00	0.400	100.0	44	570
** 4715HS-24T-B5A-A00	240	50	175	0.150	18.0	2600	91.8	2.60	0.380	94.0	40	570
** 4715HS-24T-B5A-A00	240	60	175	0.120	15.5	3100	105.9	3.00	0.400	100.0	44	570

Rotation: Counterclockwise  
 \*\* Contact NMB for Availability

Airflow Outlet: Air Out Over Struts

<sup>1</sup>: Maximum Values in Free Air  
<sup>2</sup>: Average Values in Free Air  
<sup>3</sup>: Minimum Values in Free Air

## General Specifications

**Motor Structure:** Shaded Pole Induction Motor  
**Motor Protection:** Impedance Protection  
**Insulation Resistance:**  
 10M Ω or over with a DC500V Megger  
**Dielectric Withstand Voltage:** AC 700V 1s  
**Allowable Ambient Temperature Range:**  
 -10°C ~ +65°C (Operating)  
 -40°C ~ +70°C (Storage)  
 (non-condensing environment)

## Expected Life

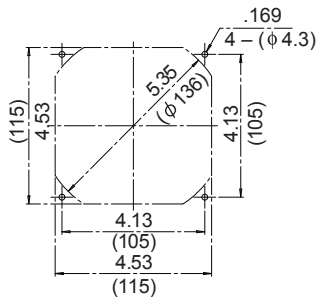
**Failure Rate: 10%**  
 25°C 100,000 Hours

## Material

**Casing :** Aluminum  
**Impeller :** Polybutylene terephthalate  
 (Glass Fiber-Containing)  
**Bearing :** Ball Bearings  
**Lead Wire :** Faston #110 or Equivalent

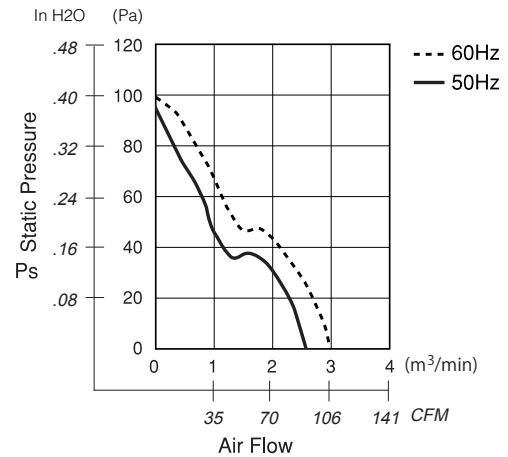
## Panel Cut-Outs

Units: inch (mm)

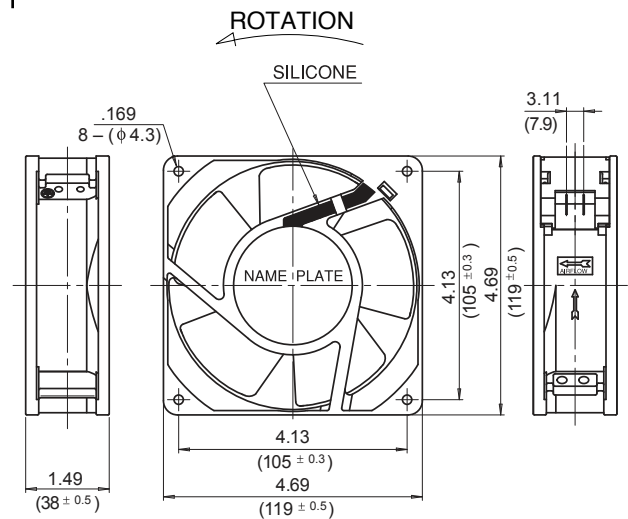


INLET SIDE / OUTLET SIDE

## Characteristic Curves



## Outline



## Specifications

MODEL	Rated Voltage	Frequency	Starting Voltage	Current	Input Power	Speed	Max. Air Flow		Max. Static Pressure		Noise	Mass
	(V)	(Hz)	(V)	(A) <sup>*1</sup>	(W)	(min <sup>-1</sup> ) <sup>*3</sup>	CFM	(m <sup>3</sup> /min) <sup>*2</sup>	in H <sub>2</sub> O	(Pa) <sup>*2</sup>	(dB) <sup>*2</sup>	(g)
** 4715HS-10T-B50-BM0	100	50	65	0.370	18.0	2600	91.8	2.60	0.380	94.0	40	610
** 4715HS-10T-B50-BM0	100	60	65	0.290	15.5	3100	105.9	3.00	0.400	100.0	44	610
4715HS-12T-B50-AM0	115	50	75	0.320	18.0	2600	91.8	2.60	0.380	94.0	40	610
4715HS-12T-B50-AM0	115	60	75	0.250	15.5	3100	105.9	3.00	0.400	100.0	44	610
** 4715HS-20T-B50-BM0	200	50	130	0.180	18.0	2600	91.8	2.60	0.380	94.0	40	610
** 4715HS-20T-B50-BM0	200	60	130	0.150	15.5	3100	105.9	3.00	0.400	100.0	44	610
** 4715HS-22T-B50-BM0	220	50	145	0.160	18.0	2600	91.8	2.60	0.380	94.0	40	610
** 4715HS-22T-B50-BM0	220	60	145	0.130	15.5	3100	105.9	3.00	0.400	100.0	44	610
4715HS-23T-B50-AM0	230	50	175	0.160	18.0	2600	91.8	2.60	0.380	94.0	40	610
4715HS-23T-B50-AM0	230	60	175	0.120	15.5	3100	105.9	3.00	0.400	100.0	44	610
** 4715HS-24T-B50-AM0	240	50	175	0.150	18.0	2600	91.8	2.60	0.380	94.0	40	610
** 4715HS-24T-B50-AM0	240	60	175	0.120	15.5	3100	105.9	3.00	0.400	100.0	44	610

Rotation: Counterclockwise

Airflow Outlet: Air Out Over Struts

\*1: Maximum Values in Free Air

\*2: Average Values in Free Air

\*3: Minimum Values in Free Air

\*\* Contact NMB for Availability

## General Specifications

- Motor Structure: Shaded Pole Induction Motor
- Motor Protection: Impedance Protection
- Insulation Resistance: 10M Ω or over with a DC500V Megger
- Dielectric Withstand Voltage: AC 700V 1s
- Allowable Ambient Temperature Range:
  - 10°C ~ +70°C (Operating)
  - 40°C ~ +70°C (Storage)
  - (non-condensing environment)

## Expected Life

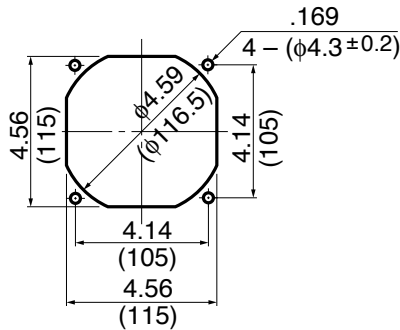
Failure Rate: 10%  
25°C 50,000 Hours

## Material

- Casing : Aluminum
- Impeller : Polycarbonate (Glass Fiber-Containing)
- Bearing : Ball Bearing
- Lead Wire : AWG22, UL3266, CSA CLR52
- or Terminal : Faston #110 or equivalent

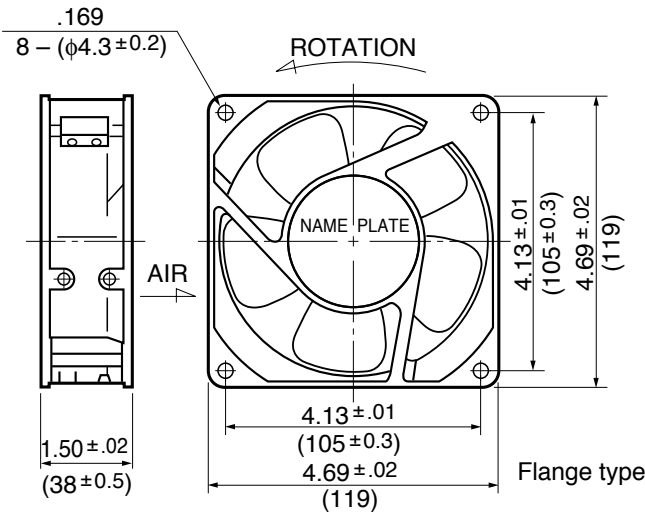
## Panel Cut-Outs

Units:  $\frac{\text{inch}}{\text{mm}}$

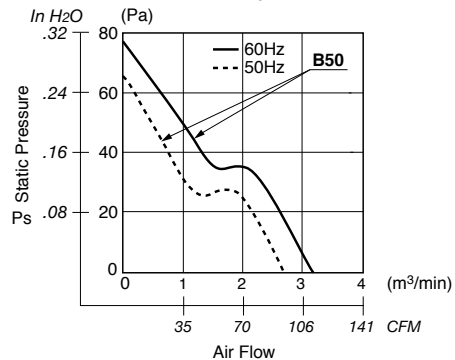
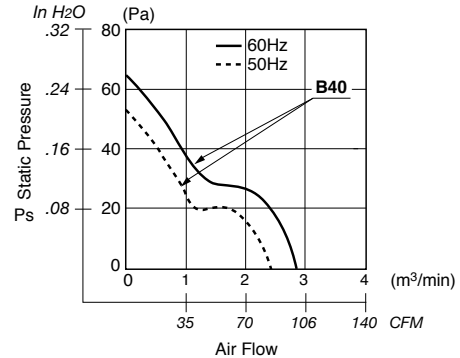
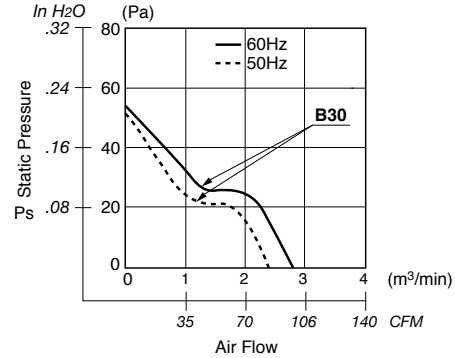
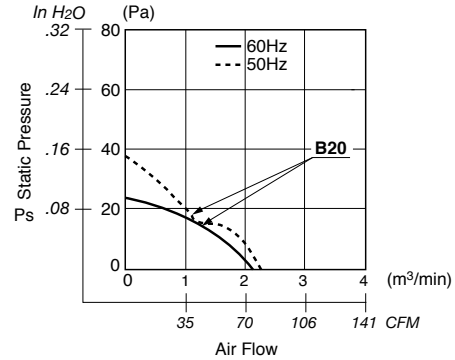
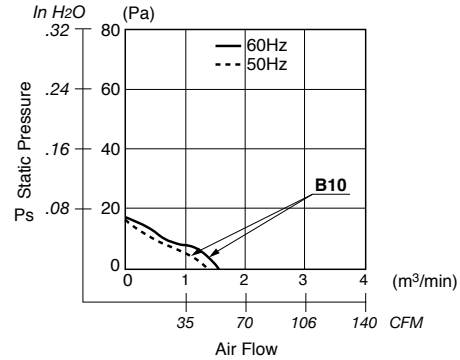


INLET SIDE / OUTLET SIDE

## Outline



## Characteristic Curves



## Specifications

MODEL	Rated Voltage	Frequency	Starting Voltage	Current	Input Power	Speed	Max. Air Flow		Max. Static Pressure		Noise	Mass
	(V)	(Hz)	(V)	(A) <sup>*1</sup>	(W) <sup>+10% -20%</sup>	(min <sup>-1</sup> ) <sup>*3</sup>	CFM	(m <sup>3</sup> /min) <sup>*3</sup>	in H <sub>2</sub> O	(Pa) <sup>*3</sup>	(dB) <sup>*2</sup>	(g)
4715MS-12T-B50-A00	115	50	65	0.250	15.5	2600	88.2	2.50	.259	64.6	37.0	550
	115	60	65	0.210	14.5	2900	102.0	2.90	.309	76.4	41.0	550
4715MS-23T-B50-A00	230	50	175	0.120	15.0	2600	88.2	2.50	.255	63.7	37.0	550
	230	60	175	0.100	14.0	2900	102.0	2.90	.283	70.5	41.0	550
4715MS-12T-B40-A00	115	50	75	0.220	15.0	2450	85.0	2.40	.204	50.9	35.0	550
	115	60	75	0.190	13.0	2750	95.0	2.70	.259	64.6	39.0	550
4715MS-23T-B40-A00	230	50	175	0.120	15.0	2450	85.0	2.40	.216	53.9	35.0	550
	230	60	175	0.100	13.0	2750	95.0	2.70	.255	63.7	39.0	550
4715MS-12T-B30-A00	115	50	75	0.160	11.0	2400	81.0	2.30	.200	49.9	34.0	550
	115	60	75	0.140	10.0	2600	88.2	2.50	.200	49.9	37.0	550
4715MS-23T-B30-A00	230	50	175	0.100	12.0	2400	81.0	2.30	.197	49.0	34.0	550
	230	60	175	0.080	11.0	2600	88.2	2.50	.208	51.9	37.0	550
4715MS-12T-B20-A00	115	50	75	0.100	7.0	2100	76.6	2.00	.141	35.2	32.0	550
	115	60	75	0.100	7.0	1950	67.0	1.90	.098	24.5	30.0	550
4715MS-23T-B20-A00	230	50	175	0.060	7.5	2100	70.6	2.00	.141	35.2	32.0	550
	230	60	175	0.060	7.5	1900	67.0	1.90	.086	21.5	30.0	550
4715MS-12T-B10-A00	115	50	75	0.090	6.0	1350	45.9	1.30	.062	15.6	27.0	550
	115	60	75	0.080	5.5	1450	49.4	1.40	.066	16.6	28.0	550
4715MS-23T-B10-A00	230	50	175	0.050	6.5	1350	45.9	1.30	.059	14.7	27.0	550
	230	60	175	0.045	6.0	1450	49.4	1.40	.059	14.7	28.0	550

Rotation: Counterclockwise

Airflow Outlet: Air Out Over Struts

\*1: Maximum Values in Free Air

\*2: Average Values in Free Air

\*3: Minimum Values in Free Air



## General Specifications

**Motor Structure:** Shaded Pole Induction Motor  
**Motor Protection:** B5A Class : Thermal Protection  
**Insulation Resistance:**  
 10M Ω or over with a DC500V Megger  
**Dielectric Withstand Voltage:** AC 700V 1s  
**Allowable Ambient Temperature Range:**  
 -10°C ~ +65°C (Operating)  
 -40°C ~ +70°C (Storage)  
 (non-condensing environment)

## Expected Life

**Failure Rate: 10%**  
 25°C 50,000 Hours

## Material

**Casing :** Aluminum  
**Impeller :** Steel  
**Bearing :** Ball Bearings  
**Lead Wire :** Faston #110 or Equivalent

## Panel Cut-Outs

Units: inch (mm)



INLET SIDE / OUTLET SIDE

## Characteristic Curves



## Outline



## Specifications

MODEL	Rated Voltage	Frequency	Starting Voltage	Current	Input Power	Speed	Max. Air Flow		Max. Static Pressure		Noise	Mass
	(V)	(Hz)	(V)	(A) <sup>1</sup>	(W)	(min <sup>-1</sup> ) <sup>3</sup>	CFM	(m³/min) <sup>2</sup>	in H <sub>2</sub> O	(Pa) <sup>2</sup>	(dB) <sup>2</sup>	(g)
** 4715TS-10T-B5A-B00	100	50	65	0.450	20.0	2600	98.84	2.80	0.352	88.0	46	610
** 4715TS-10T-B5A-B00	100	60	65	0.340	17.0	3100	116.49	3.30	0.400	100.0	50	610
4715TS-12T-B5A-A00	115	50	75	0.390	21.0	2600	98.84	2.80	0.352	88.0	46	610
4715TS-12T-B5A-A00	115	60	75	0.300	17.0	3100	116.49	3.30	0.400	100.0	50	610
** 4715TS-20T-B5A-B00	200	50	130	0.220	21.0	2600	98.84	2.80	0.352	88.0	46	610
** 4715TS-20T-B5A-B00	200	60	130	0.170	17.0	3100	116.49	3.30	0.400	100.0	50	610
** 4715TS-22T-B5A-B00	220	50	145	0.200	20.0	2600	98.84	2.80	0.352	88.0	46	610
** 4715TS-22T-B5A-B00	220	60	145	0.150	17.0	3100	116.49	3.30	0.400	100.0	50	610
4715TS-23T-B5A-A00	230	50	175	0.190	21.0	2600	98.84	2.80	0.352	88.0	46	610
4715TS-23T-B5A-A00	230	60	175	0.140	17.0	3100	116.49	3.30	0.400	100.0	50	610
** 4715TS-24T-B5A-A00	240	50	175	0.180	20.0	2600	98.84	2.80	0.352	88.0	46	610
** 4715TS-24T-B5A-A00	240	60	175	0.140	17.0	3100	116.49	3.30	0.400	100.0	50	610

Rotation: Counterclockwise  
 \*\* Contact NMB for Availability

Airflow Outlet: Air Out Over Struts

<sup>1</sup>: Maximum Values in Free Air  
<sup>2</sup>: Average Values in Free Air  
<sup>3</sup>: Minimum Values in Free Air

## General Specifications

**Motor Structure:** Shaded Pole Induction Motor  
**Motor Protection:** Impedance Protection  
**Insulation Resistance:**  
 10M  $\Omega$  or over with a DC500V Megger  
**Dielectric Withstand Voltage:** AC 700V 1s  
**Allowable Ambient Temperature Range:**  
 -10°C ~ +60°C (Operating)  
 -40°C ~ +70°C (Storage)  
 (non-condensing environment)

## Expected Life

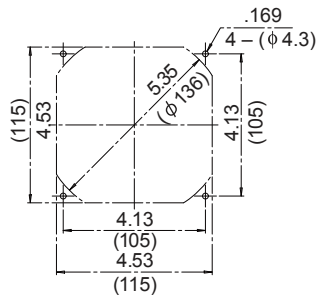
**Failure Rate: 10%**  
 25°C 50,000 Hours

## Material

**Casing :** Aluminum  
**Impeller :** Steel  
**Bearing :** Ball Bearings  
**Lead Wire :** Faston #110 or Equivalent

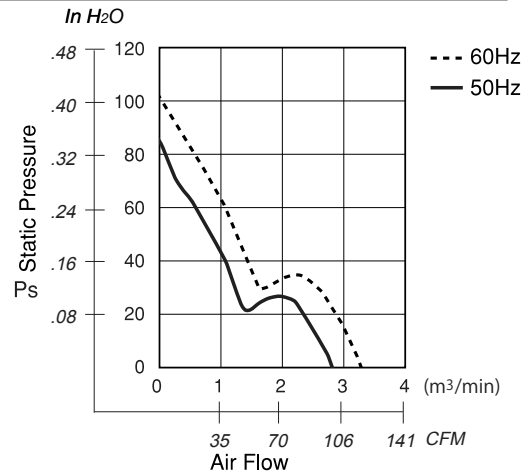
## Panel Cut-Outs

Units: inch (mm)

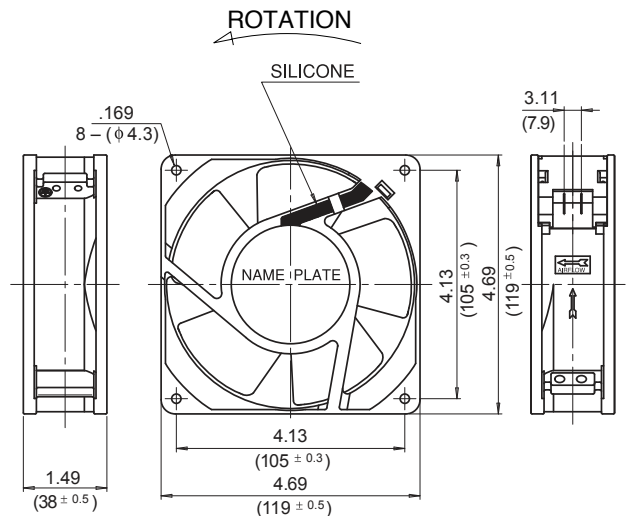


INLET SIDE / OUTLET SIDE

## Characteristic Curves



## Outline



## Specifications

MODEL	Rated Voltage	Frequency	Starting Voltage	Current	Input Power	Speed	Max. Air Flow		Max. Static Pressure		Noise	Mass
	(V)	(Hz)	(V)	(A) <sup>1</sup>	(W)	(min <sup>-1</sup> ) <sup>3</sup>	CFM	(m <sup>3</sup> /min) <sup>2</sup>	in H <sub>2</sub> O	(Pa) <sup>2</sup>	(dB) <sup>2</sup>	(g)
** 4715TS-10T-B50-BM0	100	50	65	0.450	20.0	2600	98.84	2.80	0.352	88.0	46	650
** 4715TS-10T-B50-BM0	100	60	65	0.340	17.0	3100	116.49	3.30	0.400	100.0	50	650
4715TS-12T-B50-AM0	115	50	75	0.390	21.0	2600	98.84	2.80	0.352	88.0	46	650
4715TS-12T-B50-AM0	115	60	75	0.300	17.0	3100	116.49	3.30	0.400	100.0	50	650
** 4715TS-20T-B50-BM0	200	50	130	0.220	21.0	2600	98.84	2.80	0.352	88.0	46	650
** 4715TS-20T-B50-BM0	200	60	130	0.170	17.0	3100	116.49	3.30	0.400	100.0	50	650
** 4715TS-22T-B50-BM0	220	50	145	0.200	20.0	2600	98.84	2.80	0.352	88.0	46	650
** 4715TS-22T-B50-BM0	220	60	145	0.150	17.0	3100	116.49	3.30	0.400	100.0	50	650
4715TS-23T-B50-AM0	230	50	175	0.190	21.0	2600	98.84	2.80	0.352	88.0	46	650
4715TS-23T-B50-AM0	230	60	175	0.140	17.0	3100	116.49	3.30	0.400	100.0	50	650
** 4715TS-24T-B50-AM0	240	50	175	0.180	20.0	2600	98.84	2.80	0.352	88.0	46	650
** 4715TS-24T-B50-AM0	240	60	175	0.140	17.0	3100	116.49	3.30	0.400	100.0	50	650

Rotation: Counterclockwise

Airflow Outlet: Air Out Over Struts

\*1: Maximum Values in Free Air

\*\* Contact NMB for Availability

\*2: Average Values in Free Air

\*3: Minimum Values in Free Air

### General Specifications

- Motor Structure: Capacitor-Run Induction Motor
- Motor Protection: B10~B20 Impedance Protection  
B30 Thermal Protection
- Insulation Resistance:  
10M  $\Omega$  or over with a DC500V Megger
- Dielectric Withstand Voltage: AC 700V 1s
- Allowable Ambient Temperature Range:  
-10°C ~ +70°C (Operating)  
-40°C ~ +70°C (Storage)  
(non-condensing environment)

### Expected Life

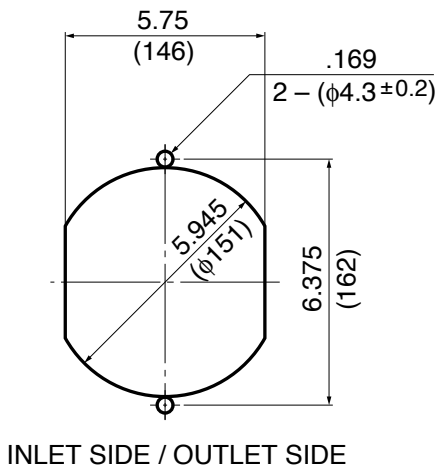
Failure Rate: 10%  
25°C 50,000 Hours

### Material

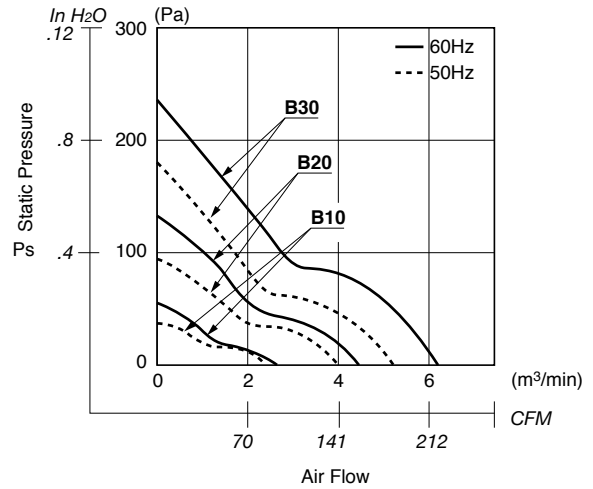
- Casing : Aluminum
- Impeller : Polycarbonate (Glass Fiber-Containing)
- Bearing : Ball Bearing
- Terminal : Faston #110 or equivalent

### Panel Cut-Outs

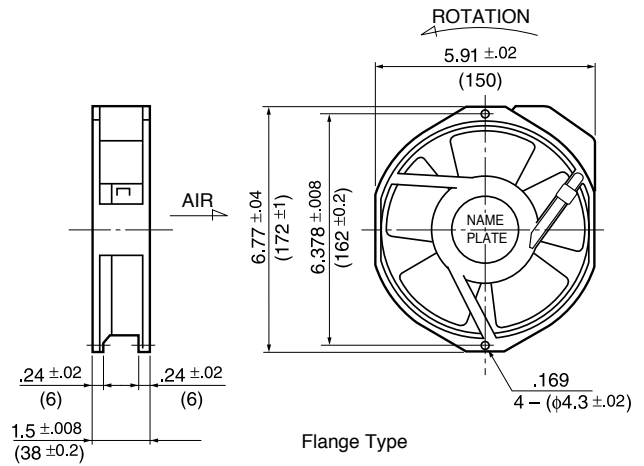
Units:  $\frac{\text{inch}}{\text{mm}}$



### Characteristic Curves



### Outline



## Specifications

AC Axial Fans

MODEL	Rated Voltage	Frequency	Starting Voltage	Current	Input Power	Speed	Max. Air Flow		Max. Static Pressure		Noise	Mass
	(V)	(Hz)	(V)	(A) <sup>1</sup>	(W) <sup>10% 20%</sup>	(min <sup>-1</sup> ) <sup>3</sup>	CFM	(m <sup>3</sup> /min) <sup>3</sup>	in H <sub>2</sub> O	(Pa) <sup>3</sup>	(dB) <sup>2</sup>	(g)
** 5915PC-10T-B30-B00	100	50	65	0.470	37.0	2700	176.5	5.00	.629	156.8	52.0	800
	100	60	65	0.440	33.0	3200	212.0	6.00	.865	215.6	56.0	800
5915PC-12T-B30-A00	115	50	75	0.380	35.0	2700	176.5	5.00	.629	156.8	52.0	800
	115	60	75	0.360	32.0	3200	212.0	6.00	.865	215.6	56.0	800
** 5915PC-20T-B30-B00	200	50	130	0.236	34.0	2700	176.5	5.00	.629	156.8	52.0	800
	200	60	130	0.210	33.0	3200	212.0	6.00	.865	215.6	56.0	800
** 5915PC-22T-B30-B00	220	50	145	0.210	40.0	2700	176.5	5.00	.629	156.8	52.0	800
	220	60	145	0.180	38.0	3200	212.0	6.00	.865	215.6	56.0	800
5915PC-23T-B30-A00	230	50	145	0.180	35.0	2700	176.5	5.00	.629	156.8	52.0	800
	230	60	145	0.190	35.0	3200	212.0	6.00	.865	215.6	56.0	800
** 5915PC-24T-B30-A00	240	50	155	0.180	34.0	2700	176.5	5.00	.629	156.8	52.0	800
	240	60	155	0.170	34.0	3200	212.0	6.00	.865	215.6	56.0	800
** 5915PC-10T-B20-B00	100	50	65	0.250	22.0	2200	141.2	4.00	.393	98.0	46.0	800
	100	60	65	0.230	23.0	2600	166.0	4.70	.472	117.6	50.0	800
5915PC-12T-B20-A00	115	50	75	0.200	21.0	2200	141.2	4.00	.393	98.0	46.0	800
	115	60	75	0.210	22.0	2600	166.0	4.70	.472	117.6	50.0	800
** 5915PC-20T-B20-B00	200	50	130	0.120	22.0	2200	141.2	4.00	.393	98.0	46.0	800
	200	60	130	0.140	23.0	2600	166.0	4.70	.472	117.6	50.0	800
** 5915PC-22T-B20-B00	220	50	145	0.110	23.0	2200	141.2	4.00	.393	98.0	46.0	800
	220	60	145	0.130	26.0	2600	166.0	4.70	.472	117.6	50.0	800
5915PC-23T-B20-A00	230	50	145	0.120	23.0	2200	141.2	4.00	.393	98.0	46.0	800
	230	60	145	0.140	26.0	2600	166.0	4.70	.472	117.6	50.0	800
** 5915PC-24T-B20-A00	240	50	145	0.100	22.0	2200	141.2	4.00	.393	98.0	46.0	800
	240	60	145	0.110	26.0	2600	166.0	4.70	.472	117.6	50.0	800
** 5915PC-10T-B10-B00	100	50	65	0.170	16.0	1400	84.7	2.40	.173	43.1	35.0	800
	100	60	65	0.020	18.0	1650	102.3	2.90	.243	60.7	38.0	800
5915PC-12T-B10-A00	115	50	75	0.160	16.0	1400	84.7	2.40	.173	43.1	35.0	800
	115	60	75	0.190	18.0	1650	102.3	2.90	.243	60.7	38.0	800
** 5915PC-20T-B10-B00	200	50	130	0.110	16.0	1400	84.7	2.40	.169	42.1	35.0	800
	200	60	130	0.130	18.0	1650	102.3	2.90	.243	60.7	38.0	800
** 5915PC-22T-B10-B00	220	50	130	0.100	16.0	1400	84.7	2.40	.169	42.1	35.0	800
	220	60	130	0.120	18.0	1650	102.3	2.90	.243	60.7	38.0	800
5915PC-23T-B10-A00	230	50	145	0.090	16.0	1400	84.7	2.40	.169	43.1	35.0	800
	230	60	145	0.110	18.0	1650	102.3	2.90	.243	60.7	38.0	800
** 5915PC-24T-B10-A00	240	50	145	0.090	16.0	1400	84.7	2.40	.169	42.1	35.0	800
	240	60	145	0.110	18.0	1650	102.3	2.90	.243	60.7	38.0	800

Rotation: Counterclockwise

Airflow Outlet: Air Out Over Struts

\*1: Maximum Values in Free Air

\*\* Contact NMB for Availability

\*2: Average Values in Free Air

\*3: Minimum Values in Free Air

## General Specifications

**Motor Structure:** Capacitor-Run Induction Motor  
**Motor Protection:** Thermal Protection  
**Insulation Resistance:**  
 10M Ω or over with a DC500V Megger  
**Dielectric Withstand Voltage:** AC 1800V 1s  
**Allowable Ambient Temperature Range:**  
 -10°C ~ +70°C (Operating)  
 -40°C ~ +70°C (Storage)  
 (non-condensing environment)

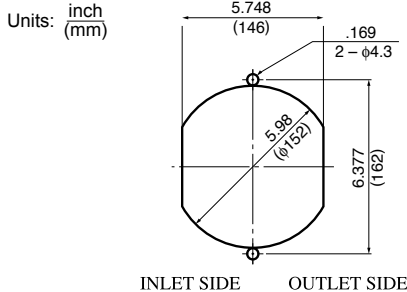
## Expected Life

**Failure Rate: 10%**  
 25°C 100,000 Hours

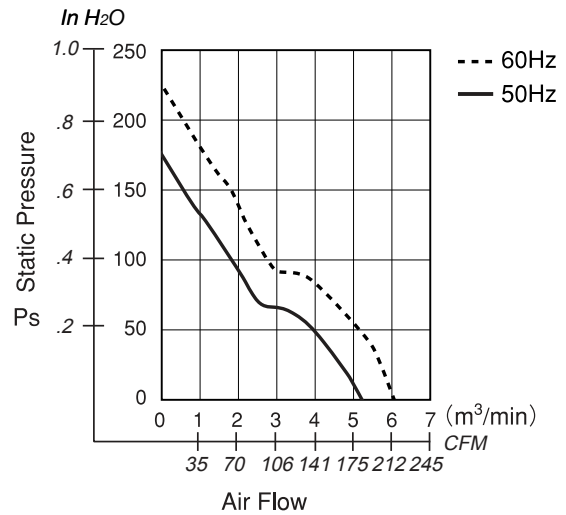
## Material

**Casing :** Aluminum  
**Impeller :** Polycarbonate (Glass Fiber-Containing)  
**Bearing :** Ball Bearing  
**Terminal :** Faston #110 or equivalent

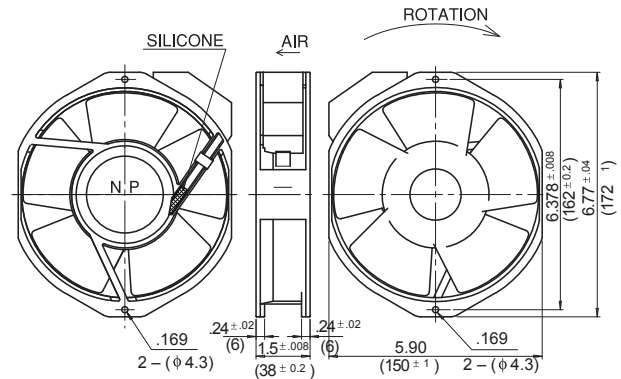
## Panel Cut-Outs



## Characteristic Curves



## Outline



## Specifications

MODEL	Rated Voltage	Frequency	Starting Voltage	Current	Input Power	Speed	Max. Air Flow		Max. Static Pressure		Noise	Mass
	(V)	(Hz)	(V)	(A) <sup>1</sup>	(W) <sup>1</sup>	(min <sup>-1</sup> ) <sup>3</sup>	CFM	(m <sup>3</sup> /min) <sup>3</sup>	in H <sub>2</sub> O	(Pa) <sup>3</sup>	(dB) <sup>2</sup>	(g)
** 5915PC-10T-B30-AM0	100	50	65	0.470	37.0	2700	176.5	5.00	0.628	157.0	52	850
** 5915PC-10T-B30-AM0	100	60	65	0.440	33.0	3200	211.8	6.00	0.863	215.8	56	850
5915PC-12T-B30-AM0	115	50	75	0.380	35.0	2700	176.5	5.00	0.628	157.0	52	850
5915PC-12T-B30-AM0	115	60	75	0.360	32.0	3200	211.8	6.00	0.863	215.8	56	850
** 5915PC-20T-B30-AM0	200	50	130	0.230	34.0	2700	176.5	5.00	0.628	157.0	52	850
** 5915PC-20T-B30-AM0	200	60	130	0.210	33.0	3200	211.8	6.00	0.863	215.8	56	850
** 5915PC-22T-B30-AM0	220	50	145	0.210	40.0	2700	176.5	5.00	0.628	157.0	52	850
** 5915PC-22T-B30-AM0	220	60	145	0.180	38.0	3200	211.8	6.00	0.863	215.8	56	850
5915PC-23T-B30-AM0	230	50	150	0.190	35.0	2700	176.5	5.00	0.628	157.0	52	850
5915PC-23T-B30-AM0	230	60	150	0.180	35.0	3200	211.8	6.00	0.863	215.8	56	850
** 5915PC-24T-B30-AM0	240	50	155	0.180	34.0	2700	176.5	5.00	0.628	157.0	52	850
** 5915PC-24T-B30-AM0	240	60	155	0.170	34.0	3200	211.8	6.00	0.863	215.8	56	850

Rotation: Counterclockwise  
 \*\* Contact NMB for Availability

Airflow Outlet: Air Out Over Struts

<sup>1</sup>: Maximum Values in Free Air  
<sup>2</sup>: Average Values in Free Air  
<sup>3</sup>: Minimum Values in Free Air

**General Specifications**

Motor Structure: Shaded Pole Induction Motor  
 Motor Protection: Impedance Protection  
 Insulation Resistance:  
 100M Ω or over with a DC500V Megger  
 Dielectric Withstand Voltage: AC 1800V 3s  
 Allowable Ambient Temperature Range:  
 -10°C ~ +60°C (Operating)  
 -40°C ~ +70°C (Storage)  
 (non-condensing environment)

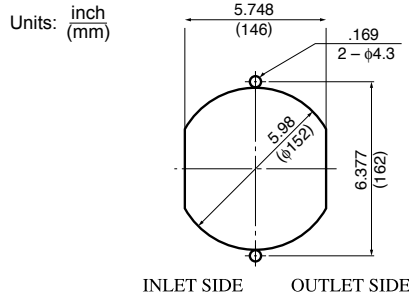
**Expected Life**

Failure Rate: 10%  
 25°C 50,000 Hours

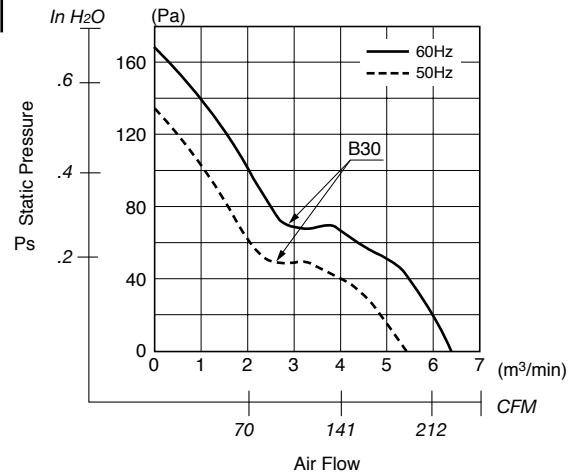
**Material**

Casing : Aluminum  
 Impeller : Steel  
 Bearing : Ball Bearing  
 Terminal : Faston #110 or equivalent

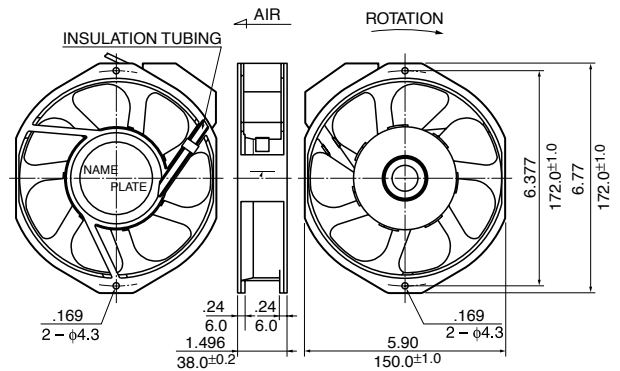
**Panel Cut-Outs**



**Characteristic Curves**



**Outline**



**Specifications**

MODEL	Rated Voltage	Frequency	Starting Voltage	Current	Input Power	Speed	Max. Air Flow		Max. Static Pressure		Noise	Mass
	(V)	(Hz)	(V)	(A) <sup>1</sup>	(W) <sup>1</sup>	(min <sup>-1</sup> ) <sup>3</sup>	CFM	(m <sup>3</sup> /min) <sup>3</sup>	in H <sub>2</sub> O	(Pa) <sup>3</sup>	(dB) <sup>2</sup>	(g)
** 5915PC-10T-B30-S00	100	50	65	0.530	42.0	2650	187.10	5.30	0.510	127.5	48	900
** 5915PC-10T-B30-S00	100	60	65	0.450	40.5	3150	222.39	6.30	0.655	163.8	53	900
5915PC-12T-B30-S00	115	50	75	0.450	40.0	2650	187.10	5.30	0.510	127.5	48	900
5915PC-12T-B30-S00	115	60	75	0.400	38.0	3150	222.39	6.30	0.655	163.8	53	900
** 5915PC-20T-B30-S00	200	50	130	0.250	42.0	2650	187.10	5.30	0.510	127.5	48	900
** 5915PC-20T-B30-S00	200	60	130	0.230	40.0	3150	222.39	6.30	0.655	163.8	53	900
** 5915PC-22T-B30-S00	220	50	145	0.250	42.0	2650	187.10	5.30	0.510	127.5	48	900
** 5915PC-22T-B30-S00	220	60	145	0.230	40.0	3150	222.39	6.30	0.655	163.8	53	900
5915PC-23T-B30-S00	230	50	150	0.220	42.0	2650	187.10	5.30	0.510	127.5	48	900
5915PC-23T-B30-S00	230	60	150	0.200	40.0	3150	222.39	6.30	0.655	163.8	53	900
** 5915PC-24T-B30-S00	240	50	155	0.200	39.0	2650	187.10	5.30	0.510	127.5	48	900
** 5915PC-24T-B30-S00	240	60	155	0.200	39.0	3150	222.39	6.30	0.655	163.8	53	900

Rotation: Counterclockwise      Airflow Outlet: Air Out Over Struts  
 \*\* Contact NMB for Availability

\*1: Maximum Values in Free Air  
 \*2: Average Values in Free Air  
 \*3: Minimum Values in Free Air

## General Specifications

**Motor Structure:** Capacitor-Run Induction Motor  
**Motor Protection:** Thermal Protection  
**Insulation Resistance:**  
 100M Ω or over with a DC500V Megger  
**Dielectric Withstand Voltage:** AC 1800V 3s  
**Allowable Ambient Temperature Range:**  
 -10°C ~ +60°C (Operating)  
 -40°C ~ +70°C (Storage)  
 (non-condensing environment)

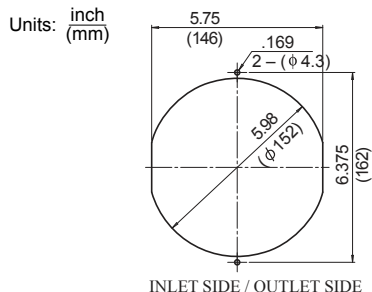
## Expected Life

**Failure Rate: 10%**  
 25°C 50,000 Hours

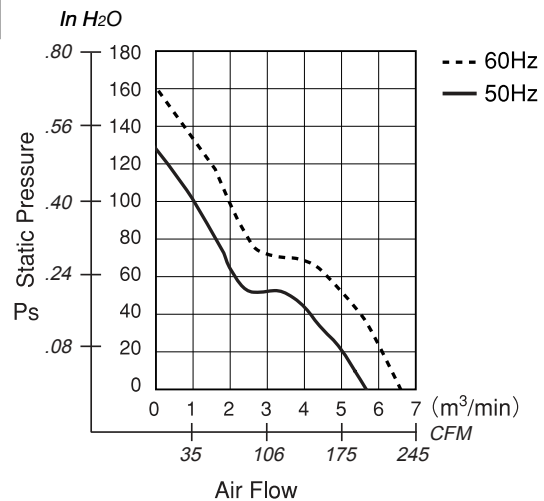
## Material

**Casing :** Aluminum  
**Impeller :** Steel  
**Bearing :** Ball Bearing  
**Terminal :** Faston #110 or equivalent

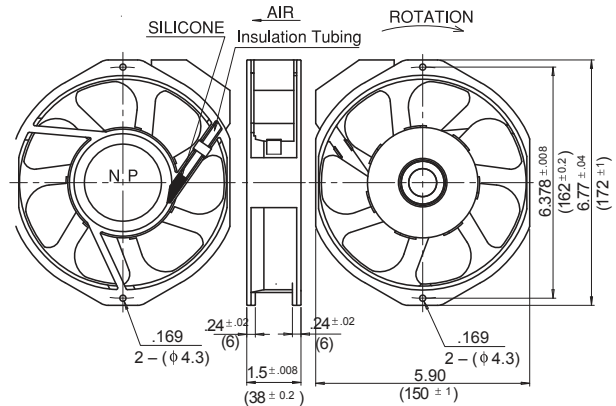
## Panel Cut-Outs



## Characteristic Curves



## Outline



## Specifications

MODEL	Rated Voltage	Frequency	Starting Voltage	Current	Input Power	Speed	Max. Air Flow		Max. Static Pressure		Noise	Mass
	(V)	(Hz)	(V)	(A) <sup>1</sup>	(W) <sup>1</sup>	(min <sup>-1</sup> ) <sup>3</sup>	CFM	(m <sup>3</sup> /min) <sup>3</sup>	in H <sub>2</sub> O	(Pa) <sup>3</sup>	(dB) <sup>2</sup>	(g)
5915PC-10T-B30-SM0	100	50	65	0.530	42.0	2650	187.10	5.30	0.510	127.5	48	950
5915PC-10T-B30-SM0	100	60	65	0.450	40.0	3150	222.39	6.30	0.655	163.8	53	950
5915PC-12T-B30-SM0	115	50	75	0.450	40.0	2650	187.10	5.30	0.510	127.5	48	950
5915PC-12T-B30-SM0	115	60	75	0.400	38.0	3150	222.39	6.30	0.655	163.8	53	950
5915PC-20T-B30-SM0	200	50	130	0.250	42.0	2650	187.10	5.30	0.510	127.5	48	900
5915PC-20T-B30-SM0	200	60	130	0.230	40.0	3150	222.39	6.30	0.655	163.8	53	950
5915PC-22T-B30-SM0	220	50	145	0.250	42.0	2650	187.10	5.30	0.510	127.5	48	900
5915PC-22T-B30-SM0	220	60	145	0.230	40.0	3150	222.39	6.30	0.655	163.8	53	950
5915PC-23T-B30-SM0	230	50	150	0.220	42.0	2650	187.10	5.30	0.510	127.5	48	950
5915PC-23T-B30-SM0	230	60	150	0.200	40.0	3150	222.39	6.30	0.655	163.8	53	950
5915PC-24T-B30-SM0	240	50	155	0.200	39.0	2650	187.10	5.30	0.510	127.5	48	950
5915PC-24T-B30-SM0	240	60	155	0.200	39.0	3150	222.39	6.30	0.655	163.8	53	950

Rotation: Counterclockwise

Airflow Outlet: Air Out Over Struts

\*1: Maximum Values in Free Air

\*2: Average Values in Free Air

\*3: Minimum Values in Free Air

FAN MODEL	UL E89936	CSA LR65829 DC Series Fan	VDE	TUV	CE
1004KL	Vol. I, S44	1087445	1507300-0023		X
1204KL	Vol. I, S37	1223044	1507300-0013		X
1404KL	Vol. I, S45	1065707	1507300-0032		X
1511FB	Vol. I, S116		1507300-0086		
1604KL	Vol. I, S40	1141408	1507300-0008		X
1606KL	Vol. I, S32	1255295	1507300-0008		X
1608KL	Vol. I, S32	1278193	1507300-0022		X
1608VL	Vol. I, S48		1507300-0048		X
1611FB	Vol. I, S111		1507300-0081		
1611FT	Vol. I, S115		1507300-0081		
1611KL	Vol. I, S86		1507300-0061		X
1611RL	Vol. I, S111		1507300-0081		X
1619FT	Vol. I, S115		1507300-0081		
1622VWB	Vol. I, S119		1507300-0081		X
1622FT	Vol. I, S115		1507300-0081		X
1910RL	Vol. I, S100		1507300-0081		X
2004KL	Vol. I, S43	1144468	1507300-0017		X
2006FL	Vol. I, S56	1124524	1507300-0042		X
2006ML	Vol. I, S96		1507300-0069		X
2106KL	Vol. I, S32	1255295	1507300-0018		X
2404KL	Vol. I, S61	1146135	1507300-0047		X
2406GL	Vol. I, S57	1124520			X
2406KL	Vol. I, S38	2500002888	1507300-0020		X
2406RL	Vol. I, S38		1507300-0031		X
2406VL	Vol. I, S38		1507300-0031		X
2408NL	Vol. I, S34	1309625	1507300-0013		X
2408VL	Vol. I, S34		1507300-0013		X
2410EL	Vol. I, S90		1507300-0010		X
2410ML	Vol. I, S33	1193855	1507300-0010		X
2410RL	Vol. I, S90		1507300-0064		X
2410SB	Vol. I, S33		1507300-0064		X
2415FB	Vol. I, S94		1507300-0067		
2415KL	Vol. I, S94		1507300-0067		X
2415RL	Vol. I, S94		1507300-0067		X
2806FL	Vol. I, S68	1243390	1507300-0056		X
2806GL	Vol. I, S84	1335659	1507300-0060		X
2806KL	Vol. I, S91	1475908	1507300-0060		X
2806RL	Vol. I, S97	1600957	1507300-0060		X
2810KL	Vol. I, S65	1188649	1507300-0008		X
3106KL	Vol. I, S46	1038727	1507300-0033		X
3106RL	Vol. I, S93		1507300-0065		X
3108NL	Vol. I, S29	1309625	1507300-0016		X
3110EL	Vol. I, S35		1507300-0088		X
3110GL	Vol. I, S35		1507300-0008		X
3110KL	Vol. I, S35	1309625	1507300-0008		X
3110RL	Vol. I, S93		1507300-0065		X
3110SB	Vol. I, S33		1507300-0065		X
3112KL	Vol. I, S35	1309625	1507300-0008		X
3115FT	Vol. I, S115		1507300-0081		X
3115RL	Vol. I, S93		1507300-0065		X
3122FT	Vol. I, S115		1507300-0081		
3610EL	Vol. I, S31		1507300-0008		X
3610FL	Vol. I, S99		1507300-0072		X
3610GL	Vol. I, S31	1309625			
3610KL	Vol. I, S31	1309625	1507300-0008		X
3610RL	Vol. I, S93		1507300-0065		X
3610SB	Vol. I, S31		1507300-0008		X
3610VL	Vol. I, S31		1507300-0008		X
3612KL	Vol. I, S552	1253246	1507300-0008		X
3612VL	Vol. I, S552		1507300-0008		X
3615FB	Vol. I, S551		1507300-0008		X
3615KL	Vol. I, S551	1195298	1507300-0008		X
3615ML	Vol. I, S551		1507300-0008		X
3615RL	Vol. I, S551		1507300-0008		X
4515JL			1507300-0083		
4710KL	Vol. I, S64	1174022	1507300-0049		X
4710SL	Vol. I, S64				
4712FL	Vol. I, S55	1143199	1507300-0045		
4712KL	Vol. I, S41	1143199	1507300-0008		X
4715HL	Vol. I, S72				
4715JL			1507300-0083		
4715KL	Vol. I, S36	1557150	1507300-0008		X
4715RL	Vol. I, S36		1507300-0008		X
4715SL	Vol. I, S67	1197651	1507300-0058		X
4715VL	Vol. I, S36		1507300-0008		X
5015FL	Vol. I, S58		1507300-0024		X
5015KL	Vol. I, S58		1507300-0024		X



15073-3250-1001





FAN MODEL	UL E89936	CSA LR65829	VDE	TUV	CE
FBX14	Vol. I, S113				
5910PL	Vol. I, S74	1285829	1507300-0034		X
5920FT	Vol. I, S30		1507300-0044		
5920PL	Vol. I, S30	1285831	1507300-0044		X
5920SL	Vol. I, S30				
5920VL	Vol. I, S30		1507300-0044		
6820PL	Vol. I, S30	1285831	1507300-0044		X
6820FT	Vol. I, S30		1507300-0044		
6820SL	Vol. I, S30				
6820VL	Vol. I, S30		1507300-0044		
<b>DC Blowers</b>					
BM4212	Vol. I, S104		1507300-0076		
BM4515	Vol. I, S62	1161575	1507300-0046		X
BM4520	Vol. I, S104		1507300-0076		X
FAL3F	Vol. I, S114	99935			
BM5020	Vol. I, S105		1507300-0078		X
BM5115	Vol. I, S50	1057185	1507300-0030		X
BM5125	Vol. I, S53	1082756	1507300-0022		X
BM5712	Vol. I, S104		1507300-0076		X
BM5913	Vol. I, S104		1507300-0076		
BM6015		1082756			
BM6023	Vol. I, S103		1507300-0075		
BM6025	Vol. I, S103		1507300-0075		X
BM6625	Vol. I, S95		1507300-0066		X
BM6920	Vol. I, S95		1507300-0066		X
BG0702	Vol. I, S63	1133535			X
BG0703	Vol. I, S42	-158	1507300-0019		X
FAL5F	Vol. I, S114	099935			
BG0801	Vol. I, S98		1507300-0019		
BG0803	Vol. I, S66		1507300-0019		
BG0903	Vol. I, S59	1120644	1507300-0039		X
BG1002	Vol. I, S60	1158481			X
FAL6F	Vol. I, S114	099935			
BG1203	Vol. I, S49	1031559	1507300-0029		X
BG1402	Vol. I, S106		1507300-0029		
BG1504	Vol. I, S106		1507300-0029		
BL4447	Vol. I, S77				
BL4747	Vol. I, S49	-141			
BT1002	Vol. I, S101		1507300-0073		
<b>DC Motorized Impellers</b>					
175R Series	Vol. I, S87				X
I01R057D07	Vol. I, S109				
190R071D073XAXX	Vol. I, S80		1507300-0057		X
220R071D053XAXX	Vol. I, S107		1507300-0057		X
220R071D0731A01	Vol. I, S107		1507300-0057		X
220R071D0901A01	Vol. I, S107				
225R099D053XAXX	Vol. I, S107		1507300-0057		X
225R099D073XAXX	Vol. I, S107		1507300-0057		X
250R100D052XAXX	Vol. I, S80		1507300-0057		X
250R100D0701XXX	Vol. I, S80		1507300-0057		
250R100D072XAXX	Vol. I, S80		1507300-0057		
280R125D052XAXX	Vol. I, S71		1507300-0057		X
280R125D072XAXX	Vol. I, S71		1507300-0057		X
<b>AC Series Fan</b>					
2412PS	Vol. I, S3	1202307	1507300-1014		X
2415PS	Vol. I, S1	1202307			
3108PS	Vol. I, S1	1202307			
3110MS	Vol. I, S3		1507300-0078		X
3110PS	Vol. I, S3	1202307		R0030033	X
3115FS	Vol. I, S28	-19	1507300-0015	R0030030	X
3115PS	Vol. I, S3	1202307	1507300-0015	30781695	X
3610PS	Vol. I, S3	1202307	1507300-0006	30781695	X
3615HS	Vol. I, S118		1507300-0089		X
4710PS	Vol. I, S3	1202307	1507300-0009		X
4715FS	Vol. I, S27	1417267		30781695	X
4715HS	Vol. I, S10		1507300-0011		X
4715MS	Vol. I, S6	-10	1507300-0011	30781695	X
4715PS	Vol. I, S1	1202307	1507300-0011	30680496	X
4715TS	Vol. I, S10		1507300-0011		X
5915PC	Vol. I, S2	1202307	1507300-0012		X
<b>Wet Location Outdoor-Use Fans (AC)</b>					
4715HS-12T-B50-AMX	Vol. I, S10				
4715HS-23T-B50-AMX	Vol. I, S10				
5915PC-12V-B30-AMX	Vol. I, S2				
<b>Wet Location Outdoor-Use Fans (DC)</b>					
5920VL-05W-B7X-DRX	Vol. I, S30				
5920VL-07W-B7X-DRX	Vol. I, S30				

Agency Approvals



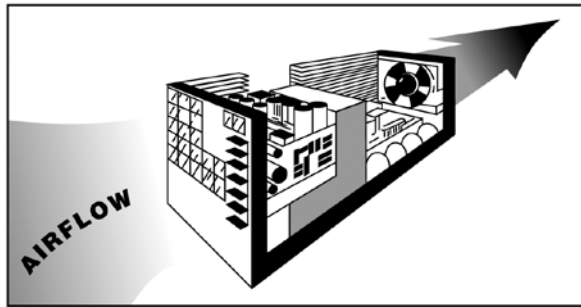
15073-3250-1001



**THERMAL DESIGN**

The need for forced-air cooling should be determined at an early stage in system design. It is important that the design plans for good airflow to heat-generating components and also allows adequate space and power for the cooling fan.

The first stage in designing a forced-air cooling system is to estimate the required airflow. This depends on the heat generated within the enclosure and the maximum temperature rise permitted.



**Enclosure with Cover Removed**

The airflow required can be obtained either by calculation or from a graph.

The equation for calculation is:

$$Q_1 = \frac{0.05 H}{\Delta T} \qquad Q_2 = \frac{1.76 H}{\Delta T}$$

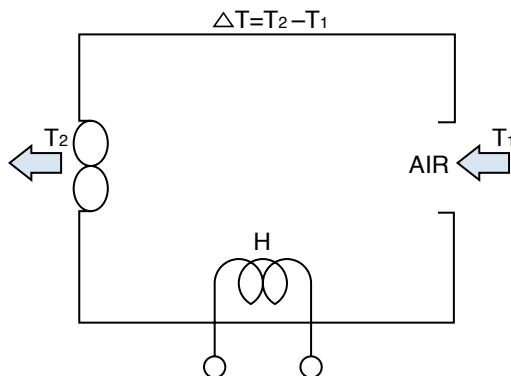
Where:

$Q_1$  = Airflow required in m<sup>3</sup>/min

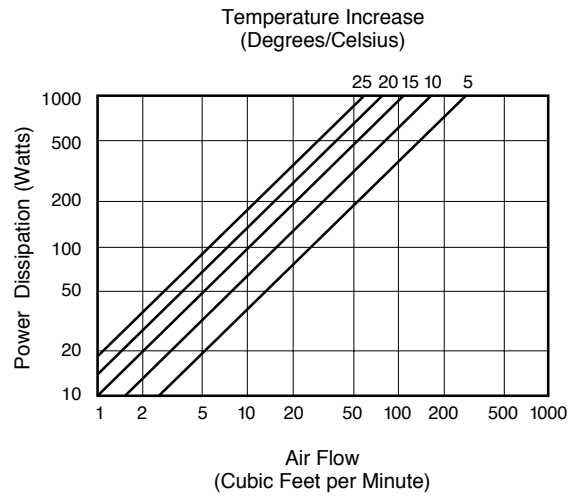
$Q_2$  = Airflow required in cubic feet/min

H = Heat dissipated in watts

$\Delta T$  = Temperature rise above inlet temp °C



In the following graph, the vertical axis represents the heat to be removed and the horizontal axis represents the airflow; both axes are logarithmic. The sloping lines define the temperature rise in °C. To use the graph, find the sloping line that represents the permitted temperature rise. Then, find the point on this line that corresponds to the heat to be removed. The horizontal position of this point shows the airflow required.



**Power Dissipation vs. Airflow for Various Temperature Increases**

**SYSTEM IMPEDANCE & OPERATING POINT**

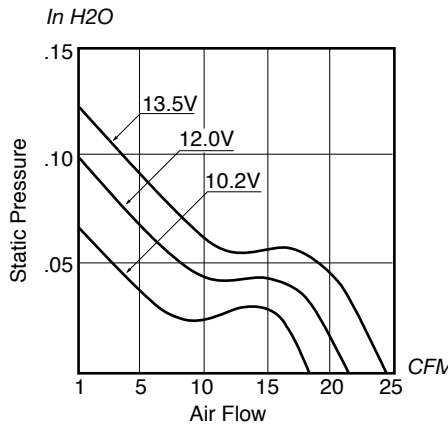
Obstructions in the airflow path cause static pressure within the enclosure. To achieve maximum airflow, obstructions should be minimized. However, obstructions in the form of baffles may be necessary to direct the airflow over the components that need cooling.

Chart 2.1 on the next page illustrates the nonlinear relationship between airflow and static pressure for a typical fan. The System Impedance curve, Chart 2.2, is a property inherent to an individual electronics enclosure. This curve can easily be generated experimentally, by testing the enclosure pressure at various airflow rates. The performance of a fan in a specific application is determined by the intersection of the System Impedance curve and the Fan Characteristic Curve, as shown on Chart 2.3.

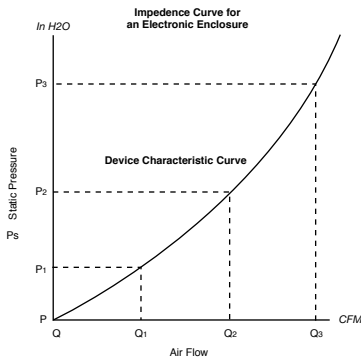
**SYSTEM IMPEDANCE & OPERATING POINT**  
(continued)

**Chart 2.1**

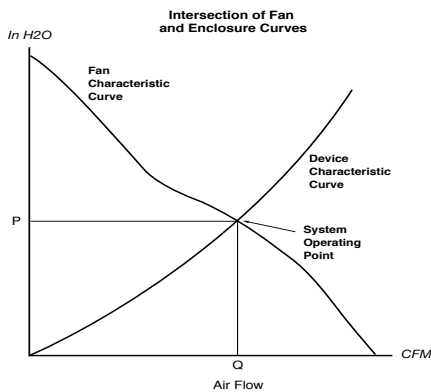
Typical relationship between Airflow and Static pressure for an Axial cooling fan.



**Chart 2.2**

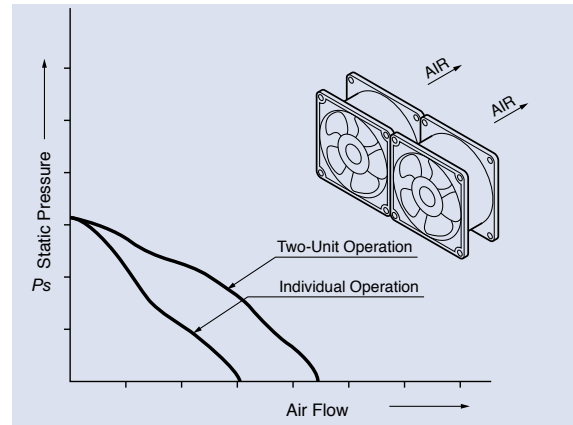


**Chart 2.3**

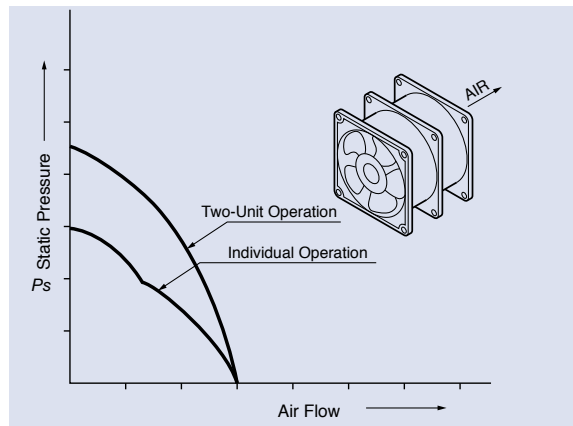


**MULTIPLE FAN USE**

The following figures show the performance characteristics for parallel and series operation of two identical fans.



**Parallel Operation**

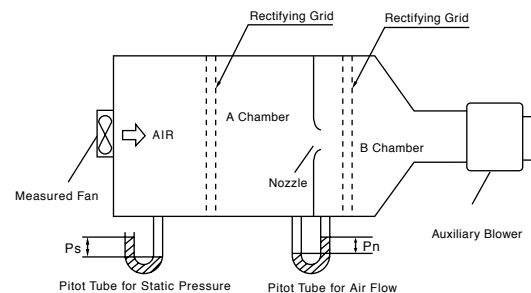


**Series Operation**

An additional fan in parallel to the first increases airflow in a low static pressure situation. An additional fan in series increases the airflow in a high static-pressure enclosure.

**AIRFLOW & PRESSURE MEASUREMENT**

An AMCA Standard 210 double chamber is used to accurately measure air volume and static pressure.



### AIRFLOW & PRESSURE MEASUREMENT (continued)

Maximum Static Pressure: When the nozzle is closed, the pressure in chamber A will reach maximum.

Maximum Airflow: When opening the nozzle and absorbing the air using the auxiliary blower to make the static pressure zero ( $P_s = 0$ ), the differential pressure ( $P_n$ ) between A chamber and B chamber will reach maximum. The airflow obtained by applying the differential pressure ( $P_n$ ) to the above equation can be called the maximum airflow.

Note: **Fan performance is calculated using the data obtained from this equipment according to the following formula:**

The Equation: Airflow

$$Q = 60 \cdot C \cdot \frac{\pi}{4} \cdot D^2 \sqrt{2g/r \cdot 0.10197 P_n} \text{ (m}^3/\text{min)}$$

- C: Coefficient of nozzle air
- D: Diameter of nozzle (m)
- r: Air density

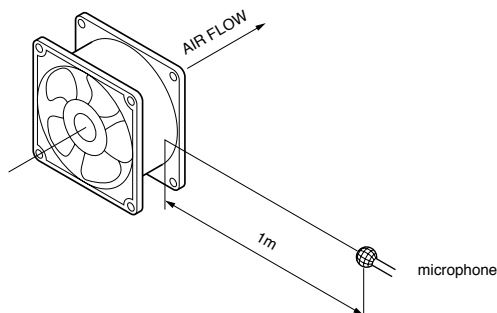
$$\left( 1.293 \times \frac{273}{273+t} \times \frac{P}{1013.25} \right) \text{ (kg/m}^3\text{)}$$

- t: Temperature (°C)
- P: Air pressure (hPa)
- $P_n$ : differential pressure of air flow (Pa)
- g:  $9.8\text{m/s}^2$

### ACOUSTIC NOISE MEASUREMENT

Noise measurements are performed in an Anechoic Chamber with less than 16 dBA background noise in compliance with JIS C 9603 standards.

- DC Fan 1 m from inlet side
- AC Fan 1 m from the side



### FAN SENSORS

Three types of DC fan sensors are available for NMB fans:

Locked Rotor Signal – outputs the status of the fan motor and is ideal for detecting if the fan motor is rotating or stopped.

Tachometer Signal – set to produce two cycles of rectangular waveform as the fan motor makes one rotation and is ideal for detecting speed.

Life Signal – detects a reduction in fan speed at a specified RPM level.

#### Locked Rotor Alarm Signal:

Output Circuit: Open Collector

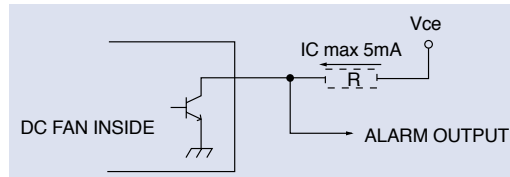
Specifications:

Vce max: +30V

Vce max: +15V(1004KL, 1404KL, 1204KL, 1604KL, 1606KL, 1608KL, 2004KL, 2106KL, 2406KL, BM4515, BM5115, BM5125, BM6015)

Ic max: 5mA (Vce(sat)max=0.4V)

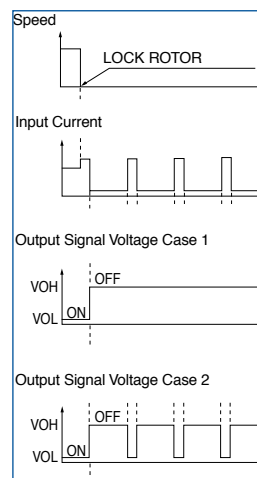
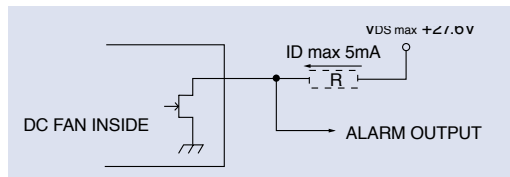
#### Alarm Signal Circuit



Alarm Signal Output: White, +:Red, -:Black

TTL output is an available option.

#### Alarm Signal Circuit

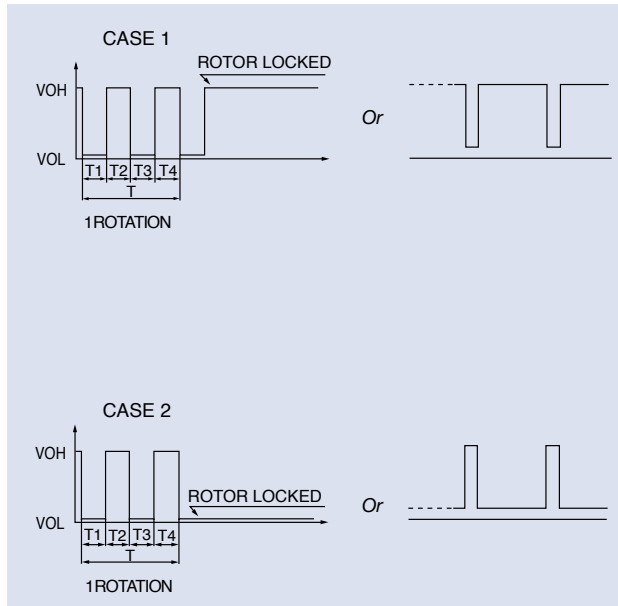


Output Waveform:

At Rated Voltage, the output signal may correspond to either Case 1 or Case 2. Your design should provide for both waveforms.

## Tachometer Signal

Output Waveform: At Rated Voltage

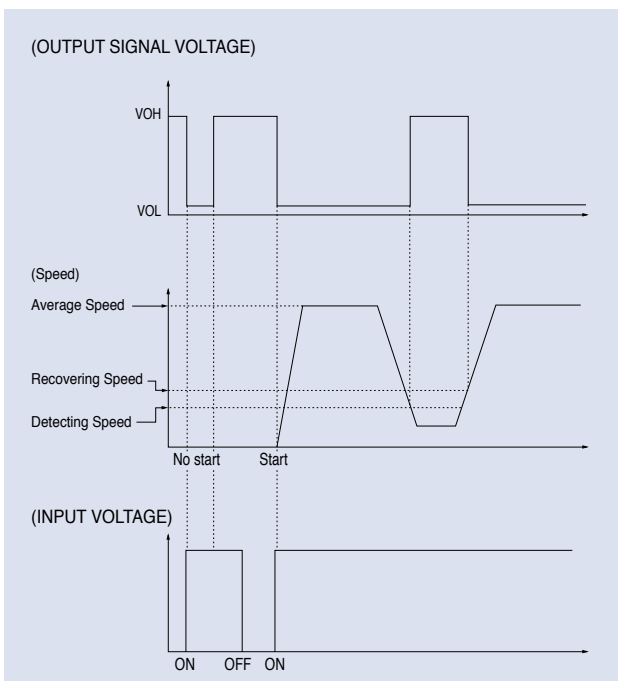


$T = T1 + T2 + T3 + T4 = 1 \text{ Rotation}$ ,  $T1 = T2 = T3 = T4 = 60/4 \text{ m}$   
 m: Rotation Speed  $\text{min}^{-1}$

The output signal may correspond to Case 1 or Case 2. Your design should provide for both waveforms.

## Life Signal

Output Waveform: At Rated Voltage



## SPEED CONTROL

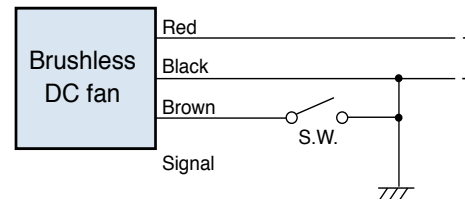
DC fan speed can be controlled in order to optimize cooling, reduce noise and decrease system power draw. There are various methods of controlling fan speed.

### 2-speed DC fan motor

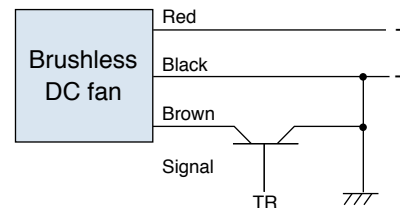
NMB's custom 2 speed fans are available with high and low speeds specified by the customer. The low end operating speed is fixed in order to reduce noise and lower power consumption.

Below is an example of an External connection for a 2-speed DC fan motor.

Control by relay contact



Control by transistor



Switch-over of fan speed

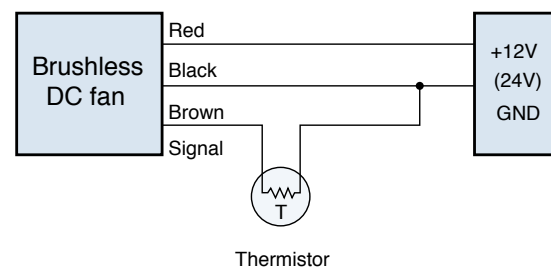
S.W. OFF: LOW SPEED, ON: HI SPEED

### Temperature Detecting Variable Speed DC Fan

The RPM may be automatically controlled and synchronized with temperature variation by installing a thermistor.

Varying the control voltage (0 to 6V) enables speed variation between the signal wire and ground.

Example of connection diagram:

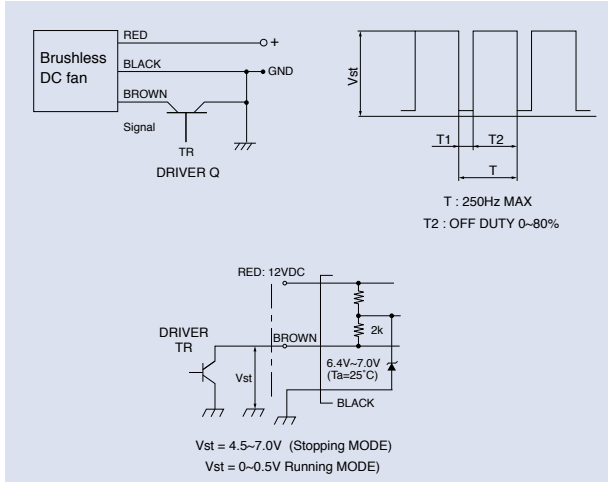


### PWM Control DC Fan

In PWM speed control, a fixed frequency square wave is applied to the speed control leadwire of the fan.

The ratio of on time vs. off time (duty cycle) is directly proportional to the speed of the fan.

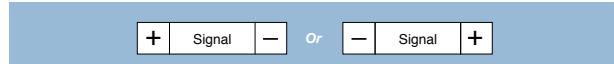
Example:



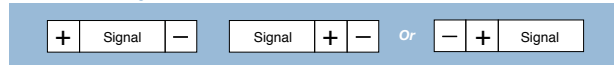
### Correct Signal Connection

Correct signal connection is important to prevent damage to the internal fan IC. Connection should be design as shown below:

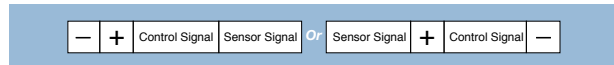
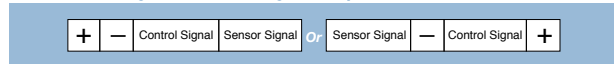
#### Signal Output



#### RPM Control Signal



#### RPM Control Signal & Sensor Signal Output



### FAN LAWS

There are various laws useful in determining different fan performance parameters. We have selected a few of these that can be useful in calculating airflow (CFM), pressure (inches H<sub>2</sub>O), power consumption (Watts), and noise (dBA), when operating at differing speeds (RPM).

Only fans of the same physical dimensions, same motor and impeller should be used for comparative analysis. The variables below are used in the formulas that follow:

Where:

- Speed\_k = Known Speed
- Speed\_n = The new speed we are using for calculation
- Airflow\_k = Known airflow at Speed\_k
- Airflow\_n = New airflow calculated at new speed
- Pressure\_k = Known Pressure at Speed\_k
- Pressure\_n = New pressure calculated at new speed
- Power\_k = Known Power at Speed\_k
- Power\_n = New Power calculated at new speed
- Noise\_k = Known Noise at Speed\_k
- Noise\_n = New Noise calculated at new speed

#### Calculating Airflow at different speeds:

$$\text{Airflow}_n = \text{Airflow}_k \left( \frac{\text{Speed}_n}{\text{Speed}_k} \right)$$

#### Calculating Pressure at different speeds:

$$\text{Pressure}_n = \text{Pressure}_k \left( \frac{\text{Speed}_n}{\text{Speed}_k} \right)^2$$

#### Calculating Power Draw at different speeds:

$$\text{Power}_n = \text{Power}_k \left( \frac{\text{Speed}_n}{\text{Speed}_k} \right)^3$$

#### Calculating Noise at different speeds:

$$\text{Noise}_n = \text{Noise}_k + 50 \log \left( \frac{\text{Speed}_n}{\text{Speed}_k} \right)^2$$

#### Airflow Calculation Example:

If a fan provides 210 CFM of airflow at 3000 RPM. What airflow (CFM) would be expected if the speed (RPM) is increased to 3500 RPM?

- Speed\_k = 3000 RPM
- Airflow\_k = 210 FM
- Speed\_n = 3500 RPM

$$\text{Airflow}_n = \text{Airflow}_k \left( \frac{\text{Speed}_n}{\text{Speed}_k} \right)$$

$$\text{Airflow}_n = 245 \text{ CFM}$$

### Pressure Calculation Example:

In the example above the fan provides 0.1 inches of H<sub>2</sub>O Pressure at the system operating point. What pressure would be expected if the fan speed were increased to 3500 RPM?

Speed<sub>k</sub> = 3000 RPM

Speed<sub>n</sub> = 3500 RPM

Pressure<sub>k</sub> = 0.1 in H<sub>2</sub>O

$$\text{Pressure}_n = \text{Pressure}_k \left( \frac{\text{Speed}_n}{\text{Speed}_k} \right)^2$$

Pressure<sub>k</sub> = 0.136 in H<sub>2</sub>O

### Power Calculation Example:

The fan in question draws 22 Watts at 3000 RPM. What power draw would be expected if the fan speed were increased to 3500 RPM?

Speed<sub>k</sub> = 3000 RPM

Speed<sub>n</sub> = 3500 RPM

Power<sub>k</sub> = 22 watt

$$\text{Power}_n = \text{Power}_k \left( \frac{\text{Speed}_n}{\text{Speed}_k} \right)^3$$

Power<sub>n</sub> = 34.935 watt

### Noise Calculation Example:

The fan in question generates 58 dBA of noise measured 1 meter from the inlet side of the fan. What would the increase in noise be if the the speed were increased form 3000 RPM to 3500 RPM?

Speed<sub>k</sub> = 3000 RPM

Speed<sub>n</sub> = 3500 RPM

Noise<sub>k</sub> = 58 dBA

$$\text{Noise}_n = \text{Noise}_k \left( \frac{\text{Speed}_n}{\text{Speed}_k} \right)$$

Noise<sub>n</sub> = 61.347 dBA

### NMB TECHNICAL SUPPORT

NMB offers a full range of application and design support services, including thermal modeling and flow analysis. For assistance with any technical issue, please contact the NMB Fan Team through our web site at [www.nmbtc.com](http://www.nmbtc.com) or e-mail us at [fans@nmbtc.com](mailto:fans@nmbtc.com).

### UNITS OF MEASURE AND CONVERSIONS

Fan airflow, static pressure, temperature, and dimensions are often referred to in a variety of unit measures. Below are the measures and methods of conversion.

#### Airflow

CFM	m <sup>3</sup> /min	m <sup>3</sup> /hr	L/sec
1	0.028	1.7	0.47
35.3	1	60	16.7
0.59	0.017	1	0.28
2.12	0.06	3.6	1

Example: To convert from CFM to m<sup>3</sup>/hr, multiply by 1.7

#### Static Pressure

in H <sub>2</sub> O	mm H <sub>2</sub> O	Pa
1	25.4	249
0.039	1	9.81
0.004	0.1	1

To convert PA to H<sub>2</sub>O, multiply by 0.004

#### Temperature

Degree F = 9/5 C + 32

Degree K = C = 273/15

#### Linear Dimensions

1mm = 0.0394" ~ 0.04

1" = 25.4mm = 2.54 cm

1U = 44.4 mm = 1.75"

## FAN LIFE AND RELIABILITY

### Fan Life Testing

Life expectancy of a cooling fan is a critical element in thermal design. NMB uses parametric failure modes during life testing to calculate for life expectancy. Speed (RPM) and Current (mA) failures include both “hard failures” (where the fan is non-functional) and “parametric failures”. These parametric failures are defined as 15% decrease in RPM and an increase in mA of 15%.

Including parametric failure modes leads to a more conservative L-10 and MTTF reporting standard than those methods that measure life performance using only hard failures.

The benefit to the customer is a fan that sets the quality and reliability standard for the cooling industry.

NMB evaluates fan life and reliability during the design phase using accelerated life testing in conjunction with ORT (Ongoing Reliability Testing). Accelerated life testing is used to compress the amount of time required to conduct life testing. Development testing occurs early in the product design, prior to product release. It is vital to characterize the reliability of the product in the initial stages of design to allow for improvements and to meet the reliability specifications prior to release to manufacturing.

Once the design has been through design verification testing and is turned over to manufacturing, ORT is conducted. For some models, ORT evaluation has continued beyond 10 years. The value of ORT is a continued refinement of the accuracy of the accelerated life testing and constant review of the design of the fan. This continued process improvement allows for ongoing evaluation and increase in fan life and reliability.

Under accelerated life testing NMB fans are tested at extreme environmental conditions, with temperature stress factors above standard operating levels. In order to gather meaningful data within a reasonable time frame, the stress factors must be accelerated to simulate different operating environments. High temperature stress is the most common stress factor used for these purposes.

Proper understanding of accelerating stresses and design limits are necessary to implement a meaningful accelerated reliability test. NMB uses the Arrhenius model for determining acceleration factors (AF) during life testing. This is the most commonly used model in accelerated life testing where thermal stress is the primary factor affecting life.

Life test data gathered from different types of fans and blowers lends to highly accurate statistical analysis. This data can produce very detailed information about the behavior of the product for reliability and prediction of fan performance in the field. The Weibull Distribution is a typical method employed by NMB for statistical analysis. An explanation of this calculation model is shown below.

### Arrhenius Weibull Model:

Life Stress Relation: Arrhenius

The Arrhenius life-stress relationship is given by:

$$\eta = L(V) = C \cdot e^{\frac{\beta}{V}}$$

Where:

- L represents a quantifiable life measure, which is the scale parameter or characteristic life of the Weibull Distribution.
- V represents the stress level (formulated for temperature and temperature values in absolute units, i.e. degrees Kelvin or degrees Rankine)
- C is one of the model parameters to be determined (  $C > 0$  ).
- B is another model parameter to be determined

### Mean Life or MTTF

The mean,  $\bar{T}$ , also called MTTF or Mean Time To Failure, of the Arrhenius-Weibull relationship is given by:

$$\bar{T} = C \cdot \frac{B}{eV} \cdot T \left( \frac{1}{\beta} + 1 \right)$$



## Reliable Life

The Arrhenius Weibull Distribution model predicts the length of time at which a defined percentage of a product population will still be operating without failing to meet pre-set criteria. For cooling fans, this is normally characterized as L10 life expectancy, or the time at which 10% of a population will have failed and 90% of a population will continue to operate within specifications.

For the Arrhenius-Weibull relationship, the reliable life, TR, of a unit for a specified reliability and starting the mission at age zero is given by:

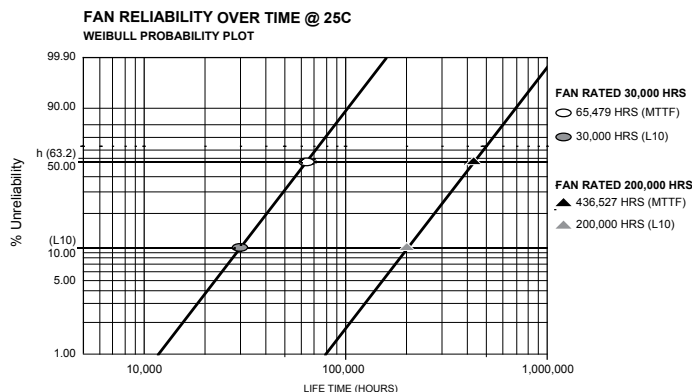
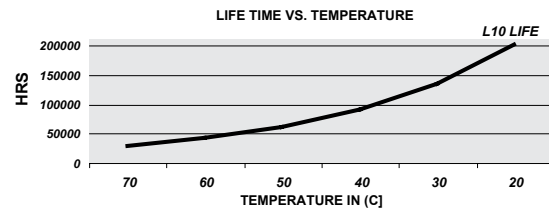
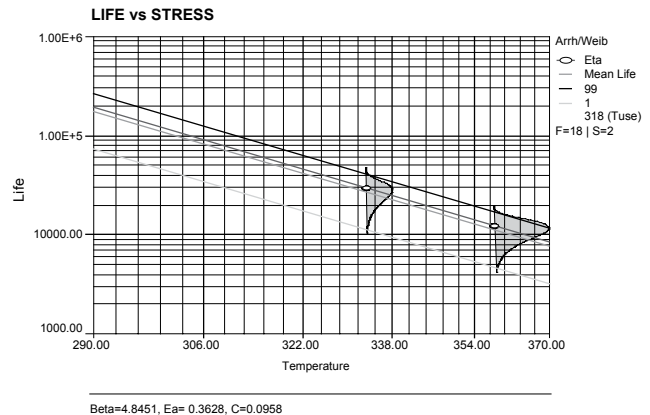
$$T_R = C \cdot \frac{B}{eV} \{-\ln[R(T_R, V)]\} \frac{1}{\beta}$$

This is the life for which the unit will function successfully with a reliability of R(TR). If R (TR) = 0.90 then TR = 90% reliability or 10% unreliability (L10) or the life by which 90% of the units will survive.

NMB uses parametric failure modes, or the condition at which a performance parameter fails to meet pre-set criteria, to record failures during accelerated life testing. This produces a more accurate prediction of field reliability than methods which use only non-operating failure modes to record failures.

Example: Life Experiment Data Using Arrhenius Weibull

Product L10 life expectancy for NMB fans ranges from 30,000 hours to 200,000 hours of continuous operation at room temperature depending on fan speed, frame size, design structure, size of ball bearings and the type of ball bearings used. NMB, a world leader in miniature precision ball bearings design and manufacturing, uses high quality, long life bearings produced in house to ensure extended fan life.



$\beta_1=2.50, \eta_1 = 73798.94$

$\beta_2=2.50, \eta_2=491992.91$

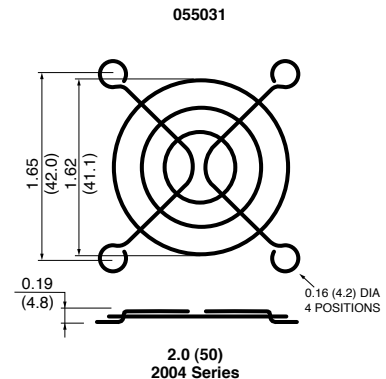
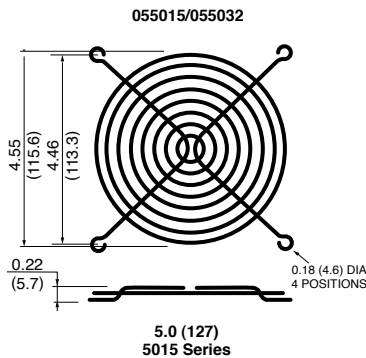
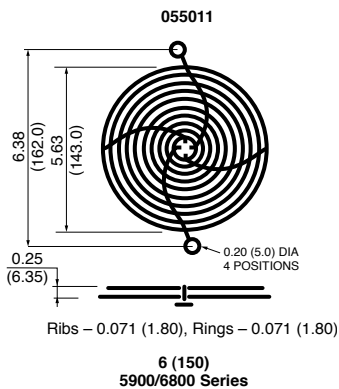
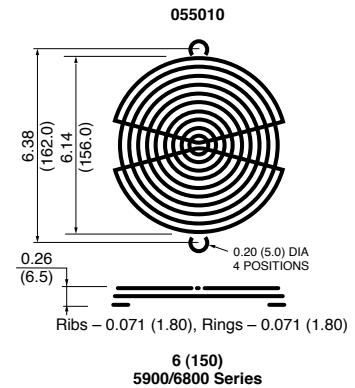
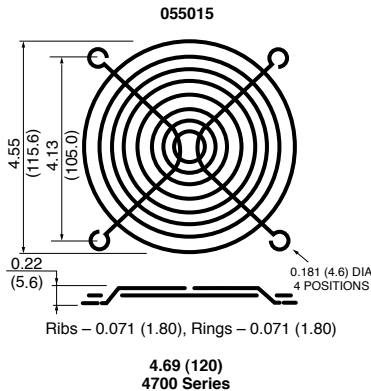
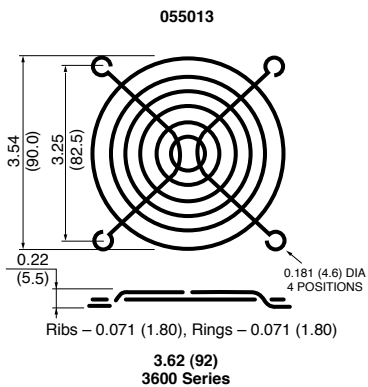
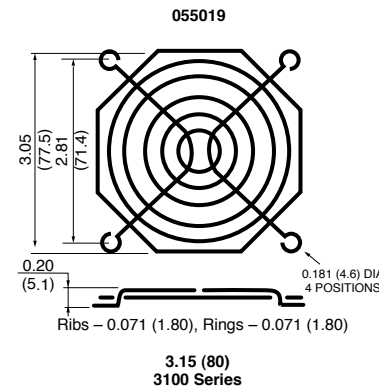
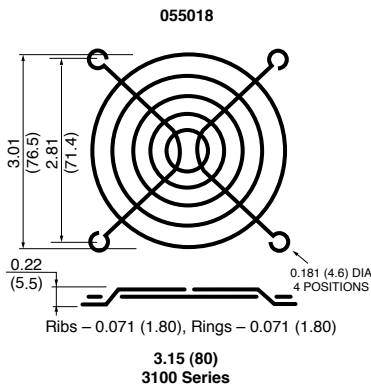
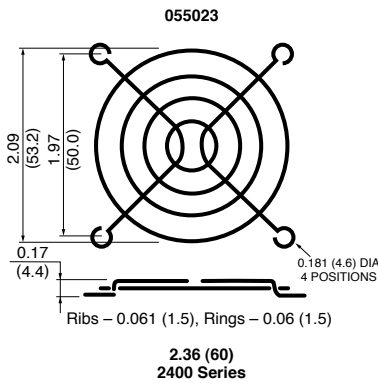
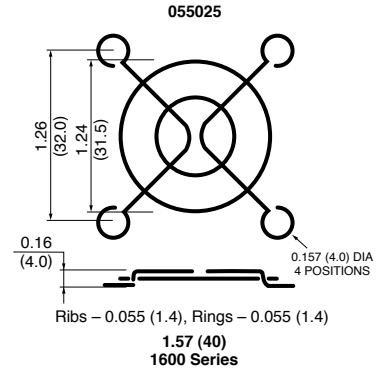
L10 - (10% Unreliability or 90% Reliability Over Time)

MTTF - (Mean Time To Failure or Mean Life)

For specific product life and reliability, please contact NMB's Applications Engineers.

**Fan Guards**

- Designed to insure safety
- Plating bright nickel chrome, black electro deposit available
- Plating thickness of .0005 min.
- Weld joints withstand 230 lbs. separation force
- Wire base C1010 steel



## Fan Guards/Mounting Clips/Cord Sets

Fan Mode	Fan Guards Part Number										Mounting Clips Part Number			Cord Sets Part Number		
	055010	055011	055013	055015	055018	055019	055023	055025	055031	055032	512011	512020	512023	432000	432002	432021
1004KL																
1204KL																
1404KL																
1604KL																
1606KL																
1608KL																
2004KL																
2106KL																
2406KL																
2408NL																
2410ML																
2410ML Vented																
3108NL																
3110KL																
3112KL																
3610KL																
3610KL Vented																
3612KL																
3615KL																
4710KL																
4712KL																
4715KL																
4715SL																
5015KL																
5020KL																
5910PL																
5920PL																
6820PL																
2412PS																
3110PS																
3115FS																
3115PS																
3610PS																
4710PS																
4715FS																
4715MS																
5915PC																

### ***NMB Fan Warranty Policy***

NMB warrants our fans to be free from defects in material and workmanship for a period of one (1) year. In order to accommodate transportation and installation we extend this warranty to 15 months from the date of manufacture.

This warranty applies to fans and blowers which are used within the design parameters and when used in an approved application. If there are any questions regarding proper application please contact your NMB representative and an applications engineer can review the customer's operational requirements.

### ***Warranty Limitations and Liability***

In the event of an operational failure of an NMB fan or blower, which was used in a manner specifically approved by NMB, NMB will at its option, repair or replace the defective fan or blower with an identical or functionally equivalent product.

In no case will NMB's liability exceed the purchase price of the defective product.

#### ***Errors***

All information, data and dimension tables in this catalog have been carefully compiled and thoroughly checked. However, no responsibility for possible errors or omissions can be assumed.

#### ***Changes***

The company reserves the right to change specifications and other information included in this catalog without notice.

# Additional Products From NMB

## Small Motors

NMB's small motor products include a line of hybrid and permanent magnet stepper motors, as well as NMB's brush and brushless DC motors. The brush DC motor line is ideal for applications that require small size and excellent power output. The brushless DC line is perfect for applications where

## Mechanical Bearing Assemblies

NMB's Miniature Precision Ball Bearings are the first component of a highly successful design of a mechanical bearing assembly. Machined components such as magnets, gears, molded and machine plastic parts, die cast parts and special materials are



the environment is sensitive to interference, battery powered equipment and clean room. Standard NMB hybrid and permanent magnet stepper motors are available, as well as many customizable features for your unique application.

For more information on our motor products, e-mail us at: [motors@nmbtc.com](mailto:motors@nmbtc.com)

## Miniature Precision Bearings

Our miniature bearings range in sizes from .1181 to 1.000 inch O.D. (3mm to 26mm), and are available in inch and metric sizes. Stainless steel or chrome steel bearings are available with crown or ribbon type metallic cages, as well as plastic crown type cages. NMB bearings are found in medical equipment, advanced automotive applications and household electrical appliances such as air conditioners, vacuum cleaners, VCRs and video cameras, and in motors for electronic controls systems, among others.

For more information on our miniature bearings, e-mail us at: [bearings@nmbtc.com](mailto:bearings@nmbtc.com)

designed and manufactured to work precisely with NMB precision ball bearings. Complex mechanical bearing assemblies are custom made to your design specifications, and are ideal for medical, office automation, and currency machines, as well as factory and lab automation applications.

For more information on our mechanical assembly products, e-mail us at: [assemblies@nmbtc.com](mailto:assemblies@nmbtc.com)

## Fan Trays

NMB's extensive selection of AC and DC cooling fans, as well as the latest range of high efficiency motorized impellers are your turn-key solution for your custom fan tray designs. NMB's fan tray product offerings include single or multiple devices, redundant and single-point of failure proof design, intelligent and self regulated control functions, two way communication with system for remote access and wide voltage range design.

For more information on our custom fan trays e-mail us at: [info@nmbtc.com](mailto:info@nmbtc.com)





ISO 14001 • ISO 9001:2008 • TS 16949 • OHSAS 18001

## ***NMB Technologies Corporation***

### North America

#### **Corporate Headquarters**

9730 Independence Avenue

Chatsworth, CA 91311

P: 818-341-3355, F: 818-341-8207

E: [info@nmbtc.com](mailto:info@nmbtc.com)

[www.nmbtc.com](http://www.nmbtc.com)

*Represented by:*

### International Sales Offices

Shanghai, China

Chennai, India

Bracknell, England

Baillet en France, France

Langen, Germany

Kowloon, Hong Kong

Milan, Italy

Tokyo, Japan

Kuala Lumpur, Malaysia

Manila, Philippines

Singapore

Seoul, South Korea

Taipei, Taiwan

Bangkok, Thailand

Hanoi, Vietnam

# Fans

DC Axial • DC Blowers • AC Axial



  
**NMB**<sup>TM</sup>  
*Minebea*

# ***NMB Technologies Corporation***



**NMB Technologies Corporation** is a subsidiary of NMB (USA) Inc., the North American headquarters and operating center of the Minebea Group of Companies. Minebea Co., Ltd., was established in 1951 as Japan's first specialized manufacturer of miniature ball bearings.

Today, the Company is the world's leading comprehensive manufacturer of miniature ball bearings and high precision components, supplying customers worldwide in the information and telecommunications equipment industry, as well as the aerospace, automotive and household electrical appliance industries.

The Minebea Group consists of 43 subsidiaries and affiliates in 16 countries, including Japan, Thailand, China and Singapore as well as several others in Europe and the Americas. The Group maintains 30 plants and 37 sales offices, and employs approximately 55,000 people worldwide.

NMB offers a comprehensive line of more than 100 axial fans ranging in size from 25mm to 173mm. DC and AC axial fans and blowers are designed to solve thermal management problems for our OEM customers. Producing over 100 million fans per year, NMB's focus is on total thermal management solutions.

NMB Technologies Corporation's domestic headquarters are located in Chatsworth, California. Highly trained application engineers, experienced product managers and customer service representatives work closely with customers to develop the most cost effective solutions for today's challenging applications. Pre-design and after-delivery follow-up assure complete customer satisfaction.

Contact NMB Technologies Corporation today. Visit our web site at [www.nmbtc.com](http://www.nmbtc.com) or call our Fan Product Group directly at 818-341-3355.





## DC Axial Fans

Common Specifications and Part Numbering System.....	1.1
Common Specifications and Part Numbering System - Turbo Fans.....	1.2
1604KL.....	1.3
1608VL.....	1.4
1619FT..... <b>NEW!</b>	1.5
2410SB.....	1.5
3110SB.....	1.7
3610SB.....	1.8
3610VL.....	1.9
4715KL.....	1.10
4715KL 3 Blade.....	1.11
4715VL.....	1.12
5920VL.....	1.13

## DC Blowers

Common Specifications and Part Numbering System.....	2.1
BM5020.....	2.2
BG0703.....	2.3
BG0903.....	2.4
BG1203.....	2.5
Notes.....	2.6

## AC Axial Fans

Common Specifications and Part Numbering System.....	3.1
2412PS.....	3.2
3110MS..... <b>NEW!</b>	3.3
3110PS.....	3.4
3115FS.....	3.5
3115PS.....	3.6-3.7
3610PS.....	3.8-3.9
4710PS.....	3.10-3.11
4715FS.....	3.12
4715HS Plastic Blades/Standard..... <b>NEW!</b>	3.13
4715HS Plastic Blades/Potting..... <b>NEW!</b>	3.14
4715MS.....	3.15-3.16
4715TS Metal Blades/Standard..... <b>NEW!</b>	3.17
4715TS Metal Blades/Potting..... <b>NEW!</b>	3.18
5915PC Plastic Blades/Standard.....	3.19-3.20
5915PC Plastic Blades/Potting..... <b>NEW!</b>	3.21
5915PC Metal Blades/Standard.....	3.22
5915PC Metal Blades/Potting..... <b>NEW!</b>	3.23

<b>Agency Approvals</b> .....	4.1-4.2
-------------------------------	---------

<b>Fan Engineering</b> .....	5.1-5.8
------------------------------	---------

<b>Accessories - Fan Guards</b> .....	6.1
---------------------------------------	-----

<b>Fan Accessories Matrix (Guards/Mounting Clips/Cord Sets)</b> .....	6.2
---	-----

<b>Warranty</b> .....	6.3
-----------------------	-----

## Common Specifications

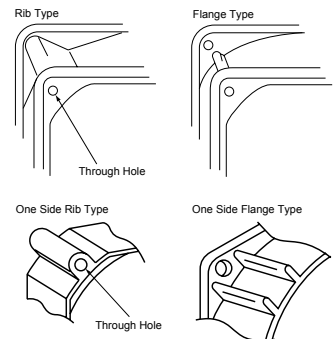
- Vibration Test:..... Conforms to JIS C 60068-2-6, Amplitude: 1.5mm, Frequency 10 to 55 Hz, 1 hour in each of the X, Y and Z directions.
- Shock Test: ..... Conforms to JIS C 60068-2-27, Acceleration rate: 981 m/s<sup>2</sup>\*, Application time: 6ms once each in the X, Y and Z directions. Note: For the 1604KL, 1608KL, and 2406KL series, the conditions of the shock test are as follows: Acceleration rate: 500 m/s<sup>2</sup>, Application time: 11ms once each in the X, Y and Z directions.
- Locked Rotor Protection : .. The motor is protected from burnout in the locked rotor condition for 72 hours at the rated voltage.
- Polarity Protection : ..... The fans are Reverse Polarity protected at the rated voltage.
- Insulation Class : ..... E class (UL: Class A)
- Auto Restart:..... Most fan models provide current shut-down/auto restart function under locked rotor conditions.

*Notes:* Additional performance requirements can be determined between manufacturer and customer, based on customer's request.  
Ball bearing fans may be installed in a horizontal, vertical or angled position

## Part Numbering System

24  
①
10  
②
M  
③
L  
④
- 04  
⑤
W  
⑥
- B  
⑦
1 0  
⑧ ⑨
- X 00  
⑩ ⑪

- |  |  |  |      |                |                |    |                |          |    |                |             |    |                |          |    |                |             |    |                |          |    |                |             |   |
|--|--|--|------|----------------|----------------|----|----------------|----------|----|----------------|-------------|----|----------------|----------|----|----------------|-------------|----|----------------|----------|----|----------------|-------------|---|
| <p><b>1. Frame Size</b></p> <ul style="list-style-type: none"> <li>10:25mm</li> <li>12:30mm</li> <li>14:35mm</li> <li>16:40mm</li> <li>20:50mm</li> <li>21:52mm</li> <li>24:60mm</li> <li>28:70mm</li> <li>31:80mm</li> <li>36:92mm</li> <li>47:119mm</li> <li>50:127mm</li> <li>59:150mm</li> <li>68:172mm</li> </ul> <p><b>2. Overall Length (Thickness)</b></p> <ul style="list-style-type: none"> <li>04:10mm</li> <li>06:15mm</li> <li>08:20mm</li> <li>10:25mm</li> <li>12:32mm</li> <li>15:38mm</li> <li>20:50mm</li> </ul> | <p><b>3. Series</b></p> <ul style="list-style-type: none"> <li>P Series</li> <li>M Series</li> <li>N Series</li> <li>K Series</li> <li>H Series</li> <li>S Series</li> <li>F Series</li> <li>R Series</li> <li>V Series</li> </ul> <p><b>4. Motor Function</b></p> <ul style="list-style-type: none"> <li>Brushless Type DCM</li> </ul> <p><b>5. Input Voltage</b></p> <ul style="list-style-type: none"> <li>O: Standard Current</li> <li>C: Special Current</li> <li>D~Z: Special Current (A.B.O. are not used)</li> <li>1: 5V    5: 24V</li> <li>2: 6V    6: 36V</li> <li>3: 9V    7: 48V</li> <li>4: 12V   9: Other</li> </ul> <p><b>6. Termination</b></p> <ul style="list-style-type: none"> <li>W: Lead Wires</li> <li>T: Terminal (Terminal option on 3610KL and 4715KL Series)</li> </ul> | <p><b>7. Bearing</b></p> <ul style="list-style-type: none"> <li>B: Ball Bearing</li> <li>S: Sleeve Bearing</li> </ul> <p><b>8. Speed</b></p> <ul style="list-style-type: none"> <li>1&lt;2&lt;3&lt;4&lt;5&lt;6&lt;7&lt;8</li> <li>low                      high</li> </ul> <p><b>9. Special Control Function</b></p> <ul style="list-style-type: none"> <li>0: Standard Type</li> <li>9: Sensor Type</li> <li>7: Temperature Detecting Variable Speed Type/PWM Control Type</li> <li>6: Temperature Detecting Variable Speed Type/Sensor Type</li> <li>5: 2-Speed Type/Sensor Type</li> <li>8: 2-Speed Type</li> </ul> <p><b>10. Product Number</b></p> <table border="0" style="width: 100%;"> <tr> <td>Item</td> <td>Classification</td> <td>Mounting Style</td> </tr> <tr> <td>L:</td> <td>Standard Model</td> <td>Rib Type</td> </tr> <tr> <td>P:</td> <td>Standard Model</td> <td>Flange Type</td> </tr> <tr> <td>B:</td> <td>Standard Model</td> <td>Rib Type</td> </tr> <tr> <td>E:</td> <td>Standard Model</td> <td>Flange Type</td> </tr> <tr> <td>G:</td> <td>Standard Model</td> <td>Rib Type</td> </tr> <tr> <td>D:</td> <td>Standard Model</td> <td>Flange Type</td> </tr> </table> | Item | Classification | Mounting Style | L: | Standard Model | Rib Type | P: | Standard Model | Flange Type | B: | Standard Model | Rib Type | E: | Standard Model | Flange Type | G: | Standard Model | Rib Type | D: | Standard Model | Flange Type | <p><b>11. Individual Specifications</b></p> <p><b>Standard Type</b></p> <ul style="list-style-type: none"> <li>00            Standard</li> <li>01~99:      Custom</li> </ul> <p><b>Sensor Type</b></p> <ul style="list-style-type: none"> <li>00:            Locked Rotor Alarm Signal (Standard)</li> <li>01~49:        Locked Rotor Alarm Signal (Custom)</li> <li>50:            Tachometer Signal (Standard)</li> <li>51~99:        Tachometer Signal (Custom)</li> </ul> |
| Item   | Classification   | Mounting Style   |      |                |                |    |                |          |    |                |             |    |                |          |    |                |             |    |                |          |    |                |             |   |
| L:   | Standard Model   | Rib Type   |      |                |                |    |                |          |    |                |             |    |                |          |    |                |             |    |                |          |    |                |             |   |
| P:   | Standard Model   | Flange Type  |      |                |                |    |                |          |    |                |             |    |                |          |    |                |             |    |                |          |    |                |             |   |
| B:   | Standard Model   | Rib Type   |      |                |                |    |                |          |    |                |             |    |                |          |    |                |             |    |                |          |    |                |             |   |
| E:   | Standard Model   | Flange Type  |      |                |                |    |                |          |    |                |             |    |                |          |    |                |             |    |                |          |    |                |             |   |
| G:   | Standard Model   | Rib Type   |      |                |                |    |                |          |    |                |             |    |                |          |    |                |             |    |                |          |    |                |             |   |
| D:   | Standard Model   | Flange Type  |      |                |                |    |                |          |    |                |             |    |                |          |    |                |             |    |                |          |    |                |             |   |



## Common Specifications

1. Tach Signal
2. Specification

$V_{psmax}$ : +15VDC  
 $I_p$  max: 5mA [ $V_{LO}$  max = 1.2V]  
 $T_a$  = 25°C

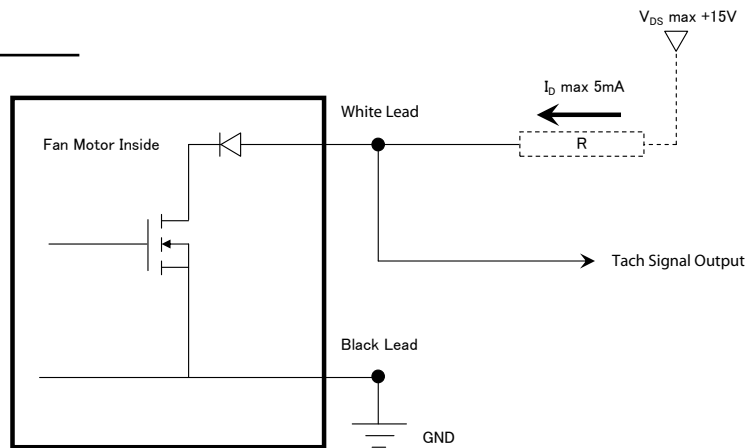
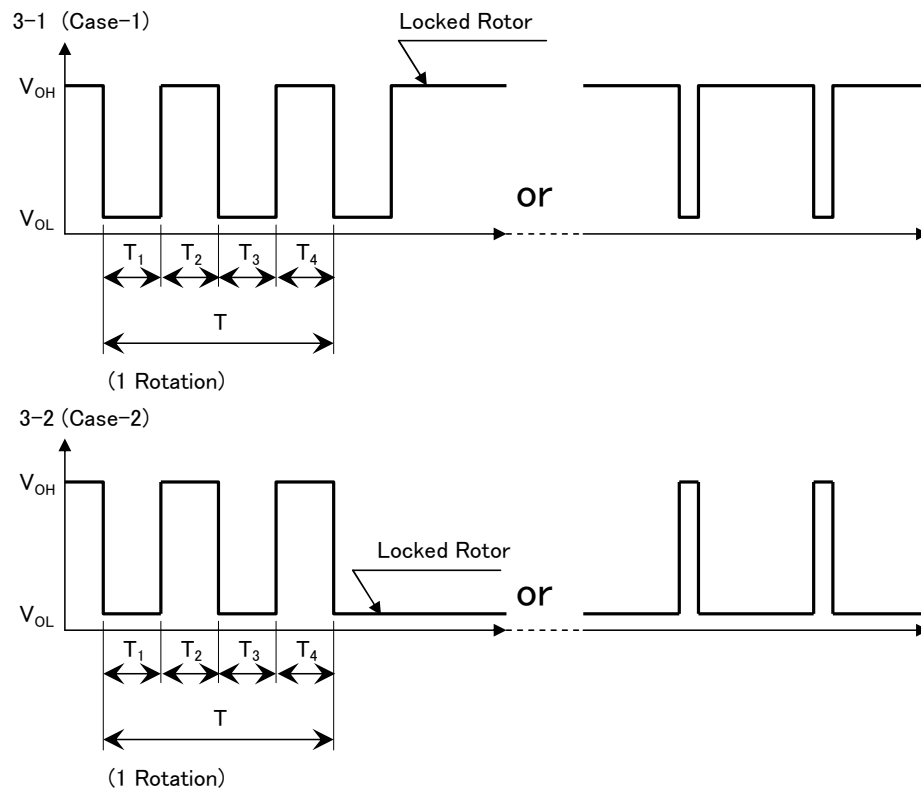


Fig. 1 Tach Signal Circuit

**Warning:** Improper connection of the sensor lead may cause damage to the motor drive IC. We shall be free from compensation, if trouble occurs due to insertion of opposite direction.



- 1.) When the rotor is locked at  $V_{OH}$  position of signal, signal keeps  $V_{OH}$  position or signal becomes to  $V_{OL}$  position for a few seconds at any time of the auto-restart motion.
- 2.) When the rotor is locked at  $V_{OL}$  position of signal, signal keeps  $V_{OL}$  position or signal becomes to  $V_{OH}$  position for a few seconds at any time of the auto-restart motion.
- 3.)  $T = T_1 + T_2 + T_3 + T_4 = 1$  Rotation  
 $T_1 = T_2 = T_3 = T_4 = 60/4m \text{ m}:(\text{min}^{-1})$

## General Specifications

- Motor Protection:**  
Auto Restart/Polarity Protection
- Insulation Resistance:**  
10M Ω or over with a DC500V Megger
- Dielectric Withstand Voltage:** AC 700V 1s
- Allowable Ambient Temperature Range:**  
-10°C ~ +70°C (Operating)  
-40°C ~ +70°C (Storage)

## Expected Life

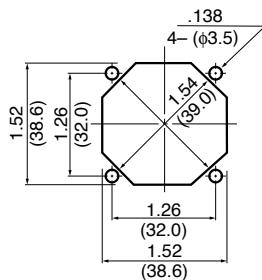
- Failure Rate: 10%**  
25°C 60,000 Hours (B00)

## Material

- Casing : Plastic (Black) 94V-0
- Impeller : Plastic (Black) 94V-0
- Bearing : Ball Bearing
- Lead Wire : UL1061, AWG26, +Red, -Black

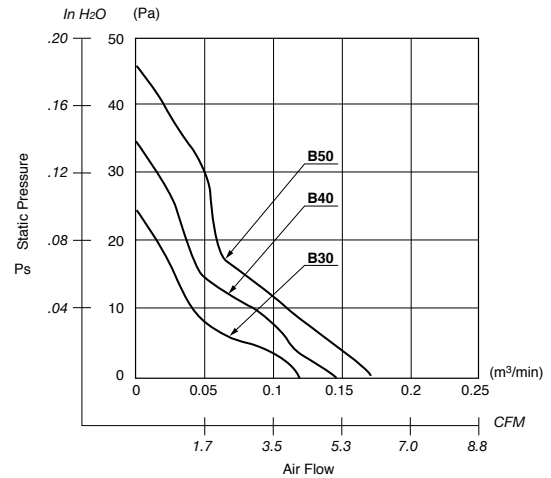
## Panel Cut-Outs

Units:  $\frac{\text{inch}}{\text{(mm)}}$

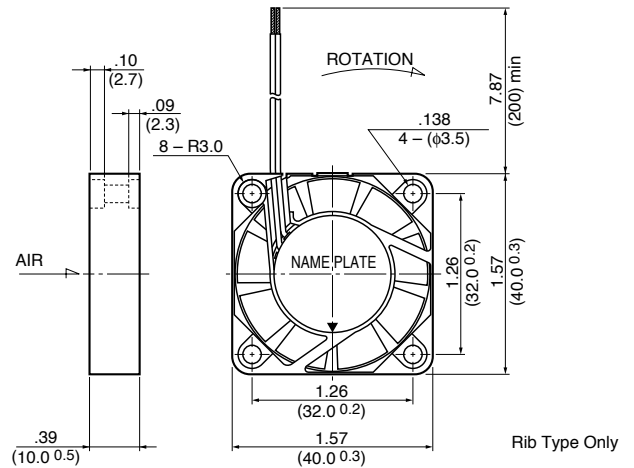


INLET SIDE / OUTLET SIDE

## Characteristic Curves



## Outline



Rib Type Only

## Specifications

MODEL	Product No.	Rated Voltage	Operating Voltage	Current	Input Power	Speed	Max. Air Flow		Max. Static Pressure		Noise	Mass
		(V)	(V)	(A) <sup>*1</sup>	(W) <sup>*1</sup>	(min <sup>-1</sup> ) <sup>*1</sup>	CFM <sup>*1</sup>	(m <sup>3</sup> /min) <sup>*1</sup>	in H <sub>2</sub> O	(Pa) <sup>*1</sup>	(dB) <sup>*1</sup>	(g)
1604KL-01W-B30-	X00	5	4.5 ~ 5.5	0.075	0.375	4500	4.2	0.12	.096	24.0	22.0	15
1604KL-01W-B40-	X00	5	4.5 ~ 5.5	0.120	0.600	5500	5.3	0.15	.136	34.0	25.0	15
1604KL-01W-B50-	X00	5	4.5 ~ 5.5	0.155	0.775	6500	6.0	0.17	.184	46.0	29.0	15
1604KL-04W-B30-	X00	12	10.2 ~ 13.8	0.062	0.744	4500	4.2	0.12	.096	24.0	22.0	15
1604KL-04W-B40-	X00	12	10.2 ~ 13.8	0.073	0.876	5500	5.3	0.15	.136	34.0	25.0	15
1604KL-04W-B50-	X00	12	10.2 ~ 13.8	0.073	0.876	6500	6.0	0.17	.184	46.0	29.0	15

Rotation: Clockwise

Airflow Outlet: Air Out Over Struts

\*1: Average Values in Free Air

## General Specifications

### Motor Protection:

Auto Restart/Polarity Protection

### Insulation Resistance:

10M Ω or over with a DC500V Megger

### Dielectric Withstand Voltage: AC 700V 1s

### Allowable Ambient Temperature Range:

-10°C ~ +70°C (Operating)

-40°C ~ +70°C (Storage)

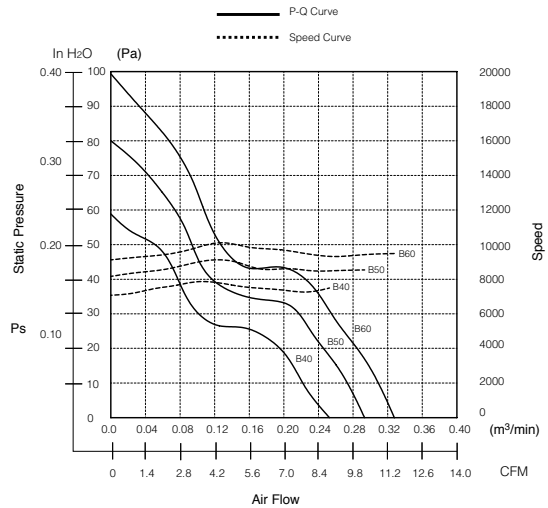
(non-condensing environment)

## Expected Life

### Failure Rate: 10%

25°C 50,000 Hours (B00)

## Characteristic Curves



## Material

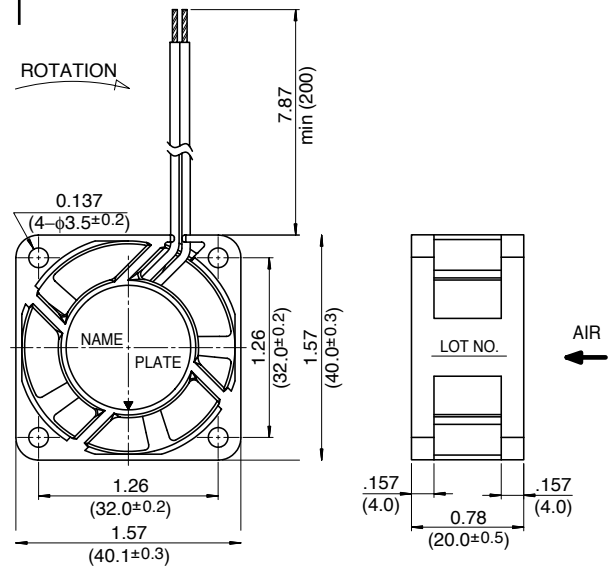
Casing : Plastic (Black) 94V-0

Impeller : Plastic (Black) 94V-0

Bearing : Ball Bearing

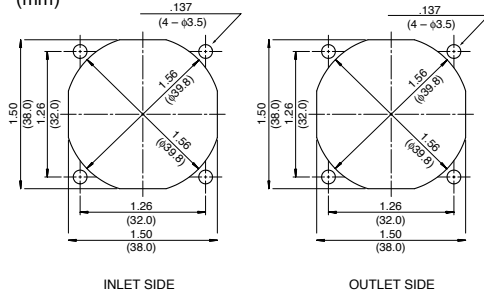
Lead Wire : UL1007, AWG26, +Red, -Black

## Outline



## Panel Cut-Outs

Units: inch (mm)



## Specifications

MODEL	Product No.	Rated Voltage	Operating Voltage	Current	Input Power	Speed	Max. Air Flow		Max. Static Pressure		Noise	Mass
		(V)	(V)	(A) <sup>*1</sup>	(W) <sup>*1</sup>	(min <sup>-1</sup> ) <sup>*1</sup>	CFM <sup>*1</sup>	(m <sup>3</sup> /min) <sup>*1</sup>	in H <sub>2</sub> O	(Pa) <sup>*1</sup>	(dB) <sup>*1</sup>	(g)
1608VL-04W-B40-	BXX	12	7.0 ~ 13.2	0.08	1.02	7500	8.8	0.25	.24	58.8	29.0	40
1608VL-04W-B50-	BXX	12	7.0 ~ 13.2	0.11	1.32	8500	10.2	0.29	.31	76.6	31.4	40
1608VL-04W-B60-	BXX	12	7.0 ~ 13.2	0.13	1.56	9500	11.3	0.32	.40	99.3	34.6	40
1608VL-05W-B40-	BXX	24	14.0 ~ 26.4	0.05	1.20	7500	8.8	0.25	.24	58.8	29.0	40
1608VL-05W-B50-	BXX	24	14.0 ~ 26.4	0.07	1.68	8500	10.2	0.29	.31	76.6	31.4	40
1608VL-05W-B60-	BXX	24	14.0 ~ 26.4	0.10	2.40	9500	11.3	0.32	.40	99.3	34.6	40

Rotation: Clockwise

Airflow Outlet: Air Out Over Struts

\*1: Average Values in Free Air

## General Specifications

### Motor Protection:

Auto Restart/Polarity Protection

### Insulation Resistance:

10M Ω or over with a DC500V Megger

### Dielectric Withstand Voltage: AC 700V 1s

### Allowable Ambient Temperature Range:

-10°C ~ +60°C (Operating)

-40°C ~ +70°C (Storage)

(non-condensing environment)

## Expected Life

### Failure Rate: 10%

40°C 70,000 Hours (B00)

## Material

Casing : Plastic (Black) 94V-0

Impeller : Plastic (Black) 94V-0

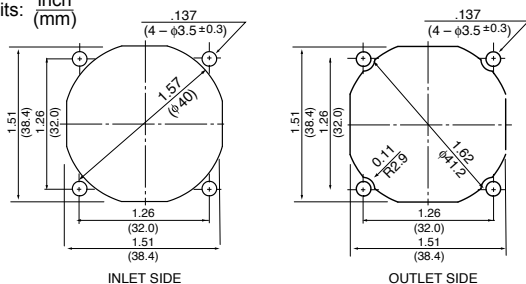
Bearing : Ball Bearing

Lead Wire : UL10368, AWG24, +Red, -Black

Tach Sig. : White PWM Control : Brown

## Panel Cut-Outs

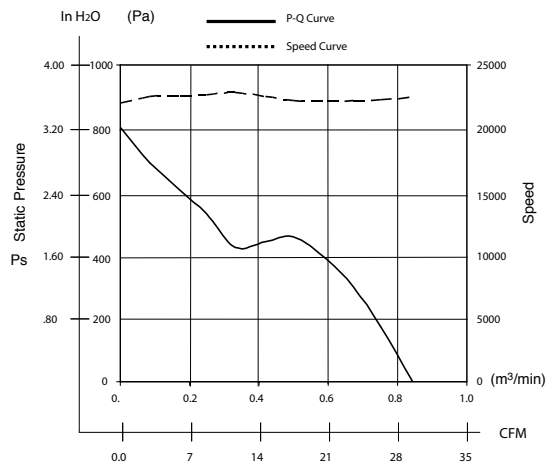
Units: inch (mm)



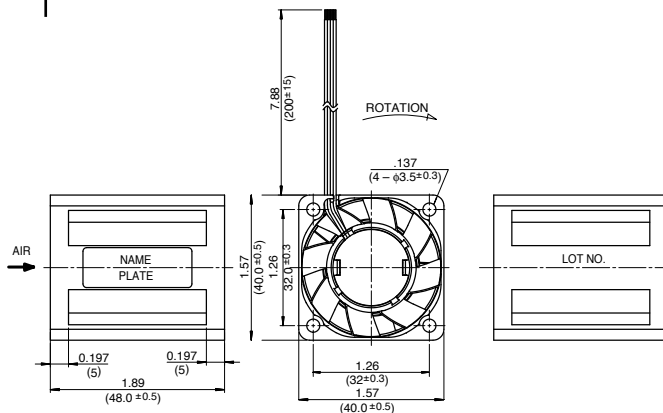
INLET SIDE

OUTLET SIDE

## Characteristic Curves



## Outline



## PWM Control Voltage

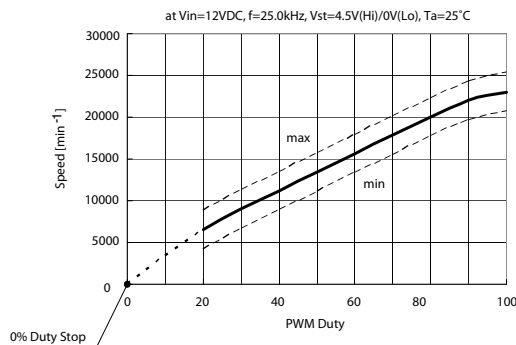
Vst = 0V ~ 0.5V Stop (On Duty 0%)

Vst = 3.3V ~ 5.0V Full Speed (On Duty 100%)

Vst = Open Full Speed

(At Ta = 25°C, rated voltage 12VDC)

## Reference PWM Duty Vs. Speed Curve



## Specifications

MODEL	Product No.	Rated Voltage	Operating Voltage	Current	Input Power	Speed	Max. Air Flow		Max. Static Pressure		Noise	Mass
		(V)	(V)	(A) <sup>*1</sup>	(W) <sup>*1</sup>	(min <sup>-1</sup> ) <sup>*1</sup>	CFM <sup>*1</sup>	(m <sup>3</sup> /min) <sup>*1</sup>	in HzO	(Pa) <sup>*1</sup>	(dB) <sup>*1</sup>	(g)
1619FT-04W-B86-	BXX	12	10.8 ~ 13.2	1.05	12.60	23,000	28.9	0.82	3.29	820.0	62.0	71

Rotation: Clockwise

Airflow Outlet: Air Out Over Struts

\*1: Average Values in Free Air

## General Specifications

### Motor Protection:

Auto Restart/Polarity Protection

### Insulation Resistance:

10M Ω or over with a DC500V Megger

### Dielectric Withstand Voltage: AC 700V 1s

### Allowable Ambient Temperature Range:

-10°C ~ +70°C (Operating)

-40°C ~ +70°C (Storage)

(non-condensing environment)

## Expected Life

### Failure Rate: 10%

25°C 100,000 Hours (B00/E00)

## Material

Casing : Plastic (Black) 94V-0

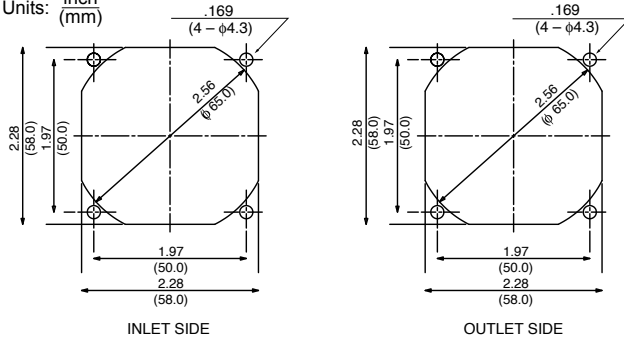
Impeller : Plastic (Black) 94V-0

Bearing : Ball Bearing

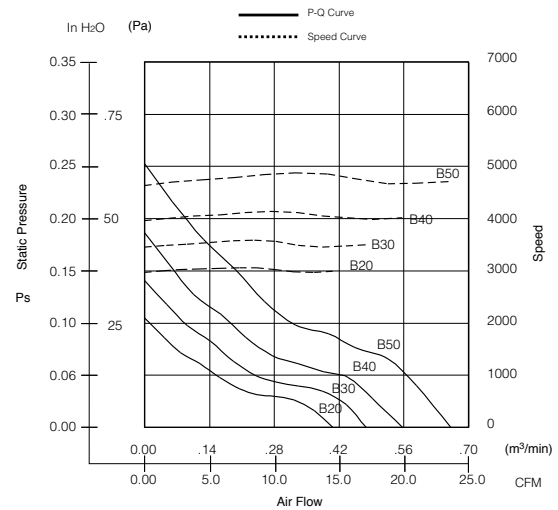
Lead Wire : UL3385, AWG26, +Red, -Black

## Panel Cut-Outs

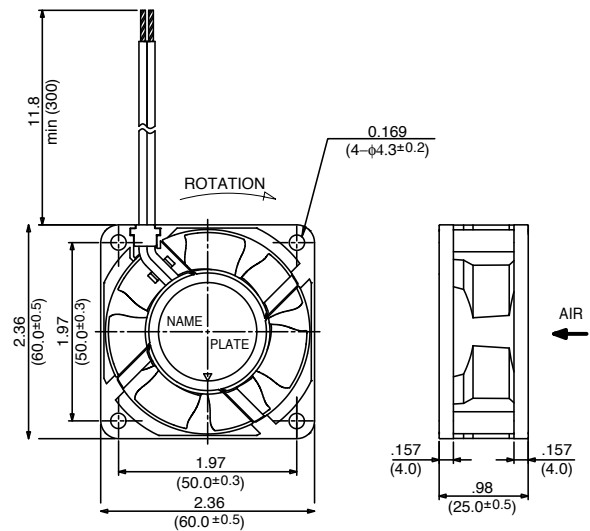
Units: inch (mm)



## Characteristic Curves



## Outline



## Specifications

MODEL	Product No.	Rated Voltage	Operating Voltage	Current	Input Power	Speed	Max. Air Flow		Max. Static Pressure		Noise	Mass
		(V)	(V)	(A) <sup>*1</sup>	(W) <sup>*1</sup>	(min <sup>-1</sup> ) <sup>*1</sup>	CFM <sup>*1</sup>	(m <sup>3</sup> /min) <sup>*1</sup>	in H <sub>2</sub> O	(Pa) <sup>*1</sup>	(dB) <sup>*1</sup>	(g)
2410SB-04W-B20	B/EXX	12	6 ~ 13.8	0.06	0.72	3000	14.5	0.41	0.10	26	17.0	56
2410SB-04W-B30	B/EXX	12	6 ~ 13.8	0.08	0.96	3500	16.9	0.48	0.14	35	22.5	56
2410SB-04W-B40	B/EXX	12	6 ~ 13.8	0.10	1.20	4000	19.8	0.56	0.18	46	26.5	56
2410SB-04W-B50	B/EXX	12	6 ~ 13.8	0.15	1.80	4700	23.3	0.66	0.25	63	32.0	56
2410SB-05W-B20	B/EXX	24	12.0 ~ 27.6	0.03	0.72	3000	14.5	0.41	0.10	26	17.0	56
2410SB-05W-B30	B/EXX	24	12.0 ~ 27.6	0.04	0.96	3500	16.9	0.48	0.14	35	22.5	56
2410SB-05W-B40	B/EXX	24	12.0 ~ 27.6	0.06	1.44	4000	19.8	0.56	0.18	46	26.5	56
2410SB-05W-B50	B/EXX	24	12.0 ~ 27.6	0.08	1.92	4700	23.3	0.66	0.25	63	32.0	56

Rotation: Clockwise

Airflow Outlet: Air Out Over Struts

\*1: Average Values in Free Air

## General Specifications

### Motor Protection:

Auto Restart/Polarity Protection

### Insulation Resistance:

10M Ω or over with a DC500V Megger

### Dielectric Withstand Voltage: AC 700V 1s

### Allowable Ambient Temperature Range:

-10°C ~ +70°C (Operating)

-40°C ~ +70°C (Storage)

(non-condensing environment)

## Expected Life

### Failure Rate: 10%

25°C 100,000 Hours (B00/E00)

## Material

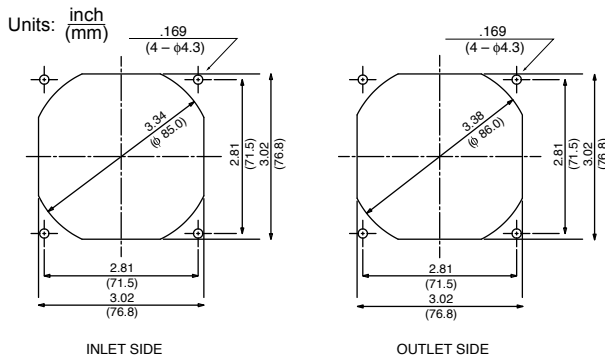
Casing : Plastic (Black) 94V-0

Impeller : Plastic (Black) 94V-0

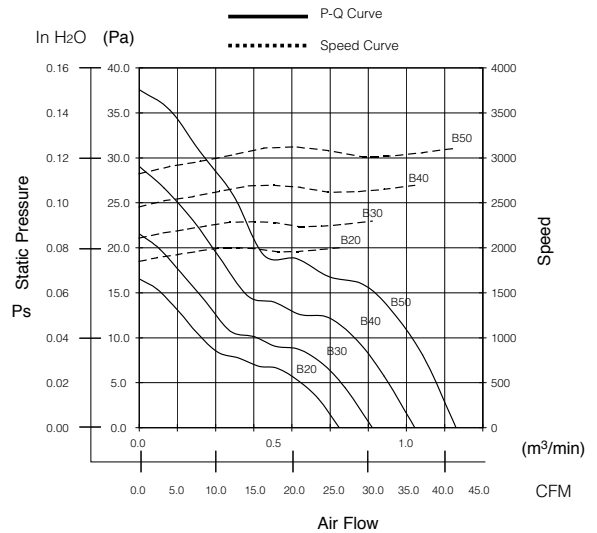
Bearing : Ball Bearing

Lead Wire : UL3385, AWG26, +Red, -Black

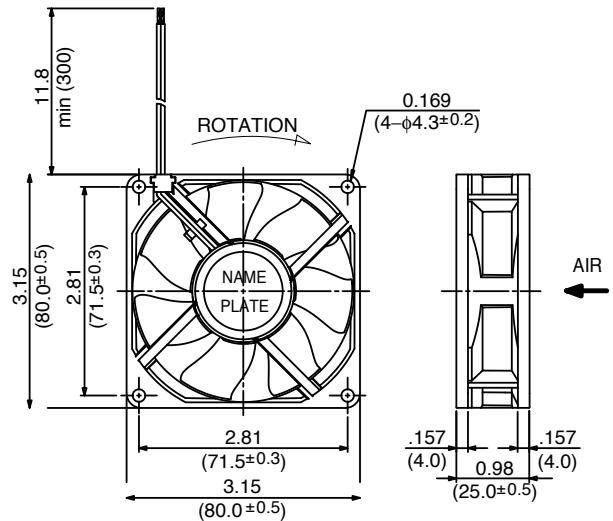
## Panel Cut-Outs



## Characteristic Curves



## Outline



## Specifications

MODEL	Product No.	Rated Voltage	Operating Voltage	Current	Input Power	Speed	Max. Air Flow		Max. Static Pressure		Noise	Mass
		(V)	(V)	(A) <sup>*1</sup>	(W) <sup>*1</sup>	(min <sup>-1</sup> ) <sup>*1</sup>	CFM <sup>*1</sup>	(m <sup>3</sup> /min) <sup>*1</sup>	in H <sub>2</sub> O	(Pa) <sup>*1</sup>	(dB) <sup>*1</sup>	(g)
3110SB-04W-B20	B/EXX	12	6 ~ 13.8	0.05	0.60	2000	26.1	0.74	0.07	16.5	19.0	80
3110SB-04W-B30	B/EXX	12	6 ~ 13.8	0.06	0.72	2300	30.4	0.86	0.09	21.5	22.0	80
3110SB-04W-B40	B/EXX	12	6 ~ 13.8	0.09	1.08	2700	36.0	1.02	0.12	29.0	26.0	80
3110SB-04W-B50	B/EXX	12	6 ~ 13.8	0.14	1.68	3100	41.3	1.17	0.15	37.5	30.0	80
3110SB-05W-B20	B/EXX	24	12.0 ~ 27.6	0.03	0.72	2000	26.1	0.74	0.07	16.5	19.0	80
3110SB-05W-B30	B/EXX	24	12.0 ~ 27.6	0.04	0.96	2300	30.4	0.86	0.09	21.5	22.0	80
3110SB-05W-B40	B/EXX	24	12.0 ~ 27.6	0.06	1.44	2700	36.0	1.02	0.12	29.0	26.0	80
3110SB-05W-B50	B/EXX	24	12.0 ~ 27.6	0.08	1.92	3100	41.3	1.17	0.15	37.5	30.0	80

Rotation: Clockwise

Airflow Outlet: Air Out Over Struts

\*1: Average Values in Free Air



## General Specifications

### Motor Protection:

Auto Restart/Polarity Protection

### Insulation Resistance:

10M Ω or over with a DC500V Megger

### Dielectric Withstand Voltage: AC 700V 1s

### Allowable Ambient Temperature Range:

-10°C ~ +70°C (Operating)

-40°C ~ +70°C (Storage)

(non-condensing environment)

## Expected Life

### Failure Rate: 10%

25°C 100,000 Hours (B00/E00)

## Material

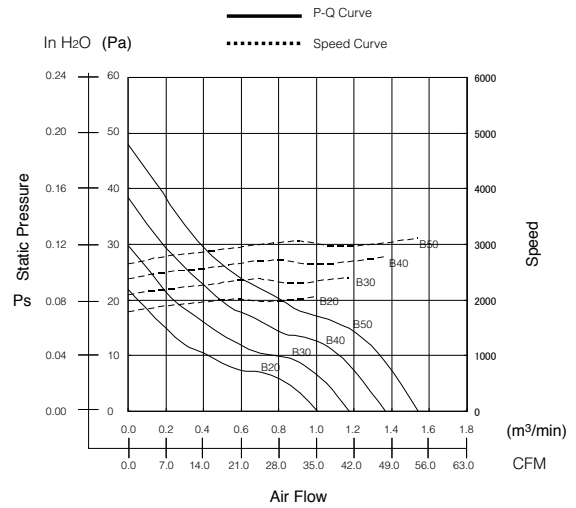
Casing : Plastic (Black) 94V-0

Impeller : Plastic (Black) 94V-0

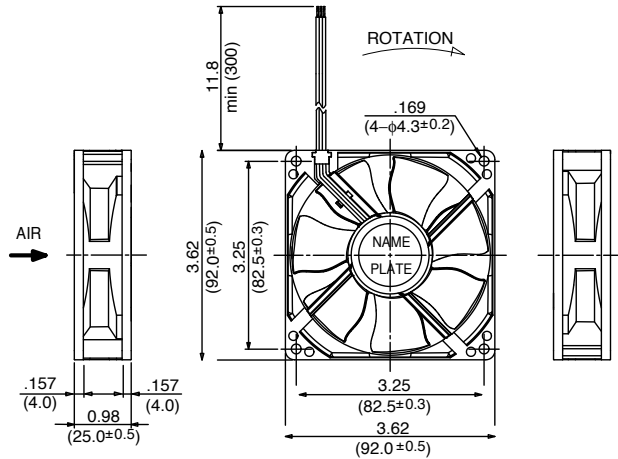
Bearing : Ball Bearing

Lead Wire : UL3385, AWG26, +Red, -Black

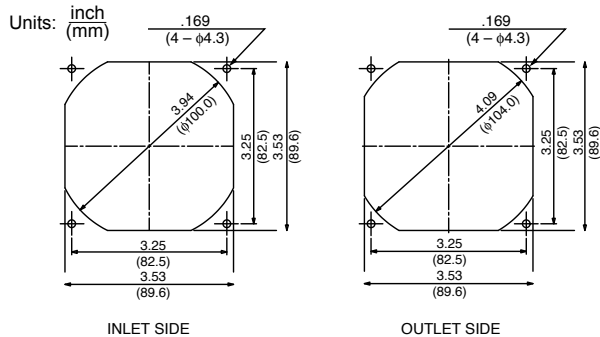
## Characteristic Curves



## Outline



## Panel Cut-Outs



## Specifications

MODEL	Product No.	Rated Voltage	Operating Voltage	Current	Input Power	Speed	Max. Air Flow		Max. Static Pressure		Noise	Mass
		(V)	(V)	(A) <sup>*1</sup>	(W) <sup>*1</sup>	(min <sup>-1</sup> ) <sup>*1</sup>	CFM <sup>*1</sup>	(m <sup>3</sup> /min) <sup>*1</sup>	in H <sub>2</sub> O	(Pa) <sup>*1</sup>	(dB) <sup>*1</sup>	(g)
3610SB-04W-B20-	B/EXX	12	6 ~ 13.8	0.07	0.84	2050	35.7	1.01	0.09	21.5	25.0	95
3610SB-04W-B30-	B/EXX	12	6 ~ 13.8	0.10	1.20	2400	41.3	1.17	0.12	29.5	28.0	95
3610SB-04W-B40-	B/EXX	12	6 ~ 13.8	0.13	1.56	2750	48.4	1.37	0.15	38.4	32.0	95
3610SB-04W-B50-	B/EXX	12	6 ~ 13.8	0.15	1.80	3100	54.4	1.54	0.19	47.9	35.0	95
3610SB-05W-B20-	B/EXX	24	12 ~ 27.6	0.04	0.84	2050	35.7	1.01	0.09	21.5	25.0	95
3610SB-05W-B30-	B/EXX	24	12 ~ 27.6	0.05	1.20	2400	41.3	1.17	0.12	29.5	28.0	95
3610SB-05W-B40-	B/EXX	24	12 ~ 27.6	0.07	1.56	2750	48.4	1.37	0.15	38.4	32.0	95
3610SB-05W-B50-	B/EXX	24	12 ~ 27.6	0.08	1.80	3100	54.4	1.54	0.19	47.9	35.0	95

Rotation: Clockwise

Airflow Outlet: Air Out Over Struts

\*1: Average Values in Free Air

## General Specifications

### Motor Protection:

Auto Restart/Polarity Protection

### Insulation Resistance:

10M Ω or over with a DC500V Megger

### Dielectric Withstand Voltage: AC 700V 1s

### Allowable Ambient Temperature Range:

-10°C ~ +70°C (Operating)

-40°C ~ +70°C (Storage)

(non-condensing environment)

## Expected Life

### Failure Rate: 10%

25°C 100,000 Hours (B00/E00)

## Material

Casing : Plastic (Black) 94V-0

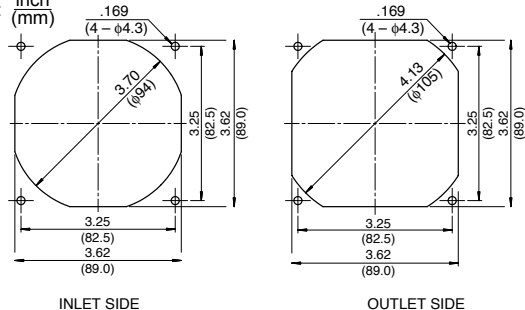
Impeller : Plastic (Black) 94V-0

Bearing : Ball Bearing

Lead Wire : UL3385, AWG26, +Red, -Black

## Panel Cut-Outs

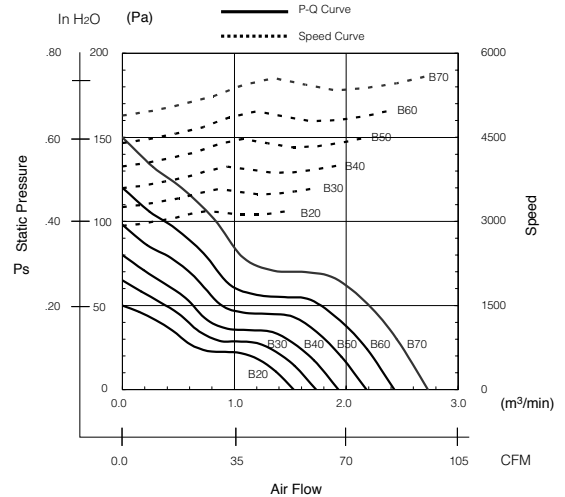
Units: inch (mm)



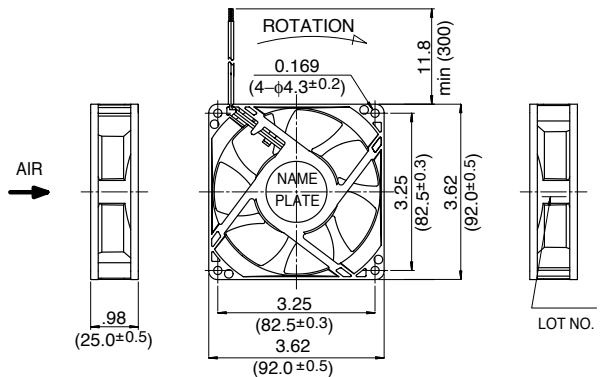
INLET SIDE

OUTLET SIDE

## Characteristic Curves



## Outline



## Specifications

MODEL	Product No.	Rated Voltage	Operating Voltage	Current	Input Power	Speed	Max. Air Flow		Max. Static Pressure		Noise	Mass
		(V)	(V)	(A) <sup>*1</sup>	(W) <sup>*1</sup>	(min <sup>-1</sup> ) <sup>*1</sup>	CFM <sup>*1</sup>	(m <sup>3</sup> /min) <sup>*1</sup>	in H <sub>2</sub> O	(Pa) <sup>*1</sup>	(dB) <sup>*1</sup>	(g)
3610VL-04W-B20-	B/EXX	12	7.0 ~ 13.8	0.18	2.16	3200	54.0	1.53	.20	50	35.5	135
3610VL-04W-B30-	B/EXX	12	7.0 ~ 13.8	0.24	2.88	3600	61.1	1.73	.26	65	38.5	135
3610VL-04W-B40-	B/EXX	12	7.0 ~ 13.8	0.30	3.60	4000	68.1	1.93	.32	80	42.0	135
3610VL-04W-B50-	B/EXX	12	7.0 ~ 13.8	0.40	4.80	4500	77.0	2.18	.39	98	45.0	135
3610VL-04W-B60-	B/EXX	12	7.0 ~ 13.8	0.52	6.24	5000	85.8	2.43	.48	120	48.0	135
3610VL-04W-B70-	B/EXX	12	7.0 ~ 13.8	0.72	8.64	5600	96.4	2.73	.60	150	51.0	135
3610VL-05W-B20-	B/EXX	24	14.0 ~ 27.6	0.11	2.64	3200	54.0	1.53	.20	50	35.5	135
3610VL-05W-B30-	B/EXX	24	14.0 ~ 27.6	0.14	3.36	3600	61.1	1.73	.26	65	38.5	135
3610VL-05W-B40-	B/EXX	24	14.0 ~ 27.6	0.17	4.08	4000	68.1	1.93	.32	80	42.0	135
3610VL-05W-B50-	B/EXX	24	14.0 ~ 27.6	0.22	5.28	4500	77.0	2.18	.39	98	45.0	135
3610VL-05W-B60-	B/EXX	24	14.0 ~ 27.6	0.28	6.72	5000	85.8	2.43	.48	120	48.0	135
3610VL-05W-B70-	B/EXX	24	14.0 ~ 27.6	0.38	9.12	5600	96.4	2.73	.60	150	51.0	135

Rotation: Clockwise

Airflow Outlet: Air Out Over Struts

\*1: Average Values in Free Air

## General Specifications

### Motor Protection:

Auto Restart/Polarity Protection

### Insulation Resistance:

10M Ω or over with a DC500V Megger

### Dielectric Withstand Voltage: AC 700V 1s

### Allowable Ambient Temperature Range:

B50 Class: -10°C ~ +40°C (Operating)

B10 ~ B40 Class: -10°C ~ +70°C (Operating)

B10 ~ B40 Class: -40°C ~ +70°C (Storage)

B50 Class: -40°C ~ +60°C (Storage)

(non-condensing environment)

## Expected Life

### Failure Rate: 10%

25°C 50,000 Hours (P00)

## Material

Casing : Plastic (Black) 94V-0

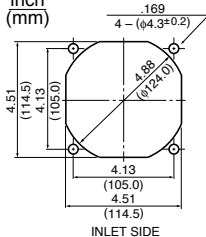
Impeller : Plastic (Black) 94V-0

Bearing : Ball Bearing

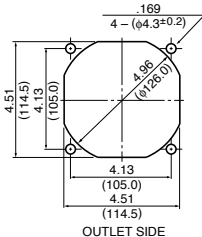
Lead Wire : UL1007, AWG24, +Red, -Black

## Panel Cut-Outs

Units:  
inch  
(mm)

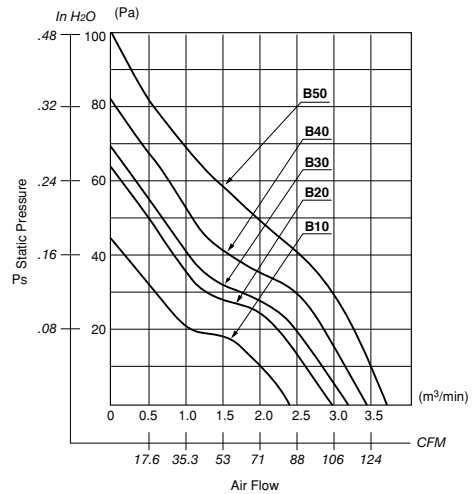


INLET SIDE

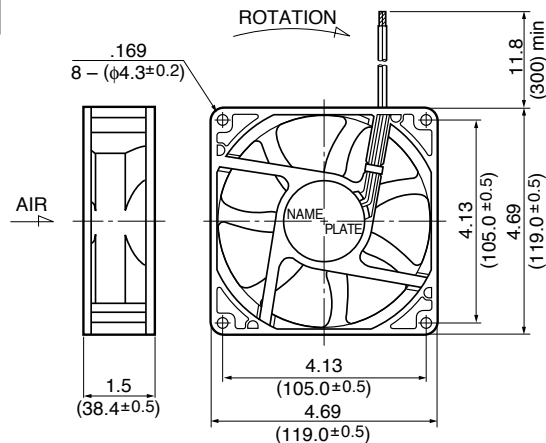


OUTLET SIDE

## Characteristic Curves



## Outline



## Specifications

MODEL	Rated Voltage	Operating Voltage	Current	Input Power	Speed	Max. Air Flow		Max. Static Pressure		Noise	Mass	
						CFM <sup>1</sup>	(m <sup>3</sup> /min) <sup>1</sup>	in H <sub>2</sub> O	(Pa) <sup>1</sup>			
4715KL-04W-B10-	X00	12	6.0 ~ 13.8	0.27	3.24	2300	83.6	2.37	.17	44.1	37.0	260
4715KL-04W-B20-	X00	12	6.0 ~ 13.8	0.40	4.80	2650	97.0	2.75	.22	55.9	41.0	260
4715KL-04W-B30-	X00	12	6.0 ~ 13.8	0.55	6.60	2950	108.0	3.07	.27	68.2	42.5	260
4715KL-04W-B40-	X00	12	6.0 ~ 13.8	0.70	8.40	3200	118.0	3.34	.33	81.4	46.5	260
4715KL-04W-B50-	X00	12	9.5 ~ 12.6	1.00	12.00	3600	129.9	3.68	.44	110.0	50.0	260
4715KL-05W-B10-	X00	24	10.0 ~ 27.6	0.15	3.60	2300	83.6	2.37	.17	44.1	37.0	260
4715KL-05W-B20-	X00	24	10.0 ~ 27.6	0.21	5.04	2650	97.0	2.75	.22	55.9	41.0	260
4715KL-05W-B30-	X00	24	10.0 ~ 27.6	0.31	7.44	2950	108.0	3.07	.27	68.2	42.5	260
4715KL-05W-B40-	X00	24	10.0 ~ 27.6	0.35	8.40	3200	118.0	3.34	.33	81.4	46.5	260
4715KL-05W-B50-	X00	24	18.0 ~ 25.0	0.50	12.00	3600	130.0	3.68	.44	110.0	50.0	260
4715KL-07W-B10-	X00	48	25.0 ~ 55.2	0.08	3.84	2300	83.6	2.37	.17	44.1	37.0	260
4715KL-07W-B20-	X00	48	25.0 ~ 55.2	0.11	5.28	2650	97.0	2.75	.22	55.9	41.0	260
4715KL-07W-B30-	X00	48	25.0 ~ 55.2	0.16	7.68	2950	108.0	3.07	.27	68.2	42.5	260
** 4715KL-07W-B40-	X00	48	25.0 ~ 55.2	0.20	9.60	3200	118.0	3.34	.33	81.4	46.5	260
4715KL-07W-B50-	X00	48	30.0 ~ 60.0	0.16	7.68	3600	130.0	3.68	.44	110.0	50.0	260

Rotation: Clockwise

Airflow Outlet: Air Out Over Struts

\*1: Average Values in Free Air

\*\* Contact NMB for availability

### General Specifications

#### Motor Protection:

Auto Restart/Polarity Protection

#### Insulation Resistance:

10M Ω or over with a DC500V Megger

#### Dielectric Withstand Voltage: AC 700V 1s

#### Allowable Ambient Temperature Range:

B50, B40 Class: -10°C ~ +45°C (Operating)

B30 Class: -10°C ~ +50°C (Operating)

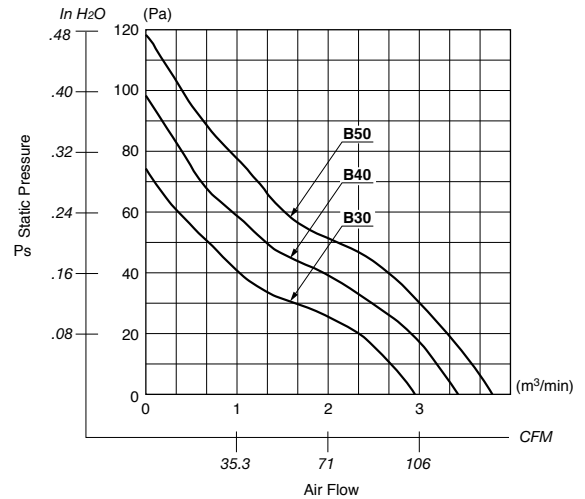
All Class: -40°C ~ +60°C (Storage)

### Expected Life

#### Failure Rate: 10%

25°C 100,000 Hours (R00)

### Characteristic Curves



### Material

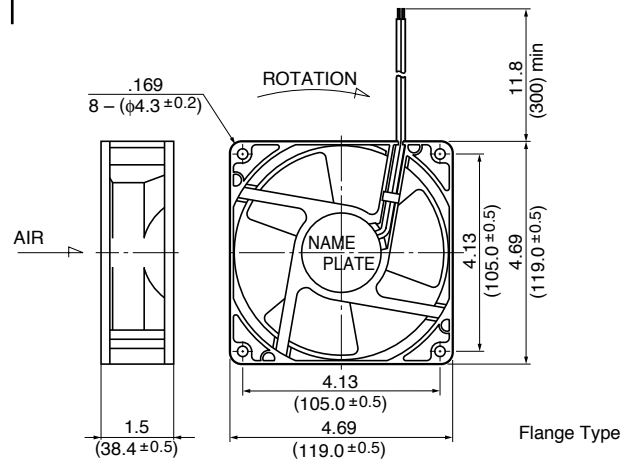
Casing : Plastic (Black) 94V-0

Impeller : Plastic (Black) 94V-0

Bearing : Ball Bearing

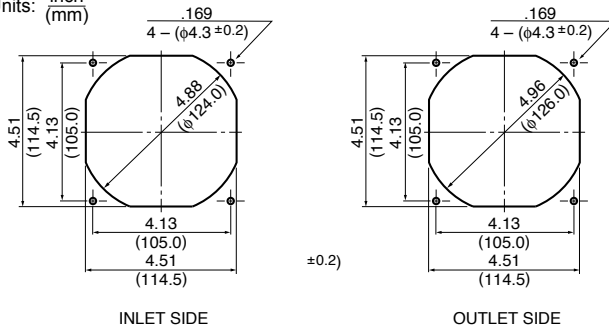
Lead Wire : UL1007, AWG26, +Red, -Black

### Outline



### Panel Cut-Outs

Units: inch (mm)



### Specifications

MODEL	Product No.	Rated Voltage	Operating Voltage	Current	Input Power	Speed	Max. Air Flow		Max. Static Pressure		Noise	Mass
		(V)	(V)	(A) <sup>*1</sup>	(W) <sup>*1</sup>	(min <sup>-1</sup> ) <sup>*1</sup>	CFM <sup>*1</sup>	(m <sup>3</sup> /min) <sup>*1</sup>	in H <sub>2</sub> O	(Pa) <sup>*1</sup>	(dB) <sup>*1</sup>	(g)
4715KL-04W-B50-	R00	12	9.5 ~ 12.6	0.85	10.2	3900	132.0	3.73	.45	113.0	54.0	260
4715KL-05W-B50-	R00	24	20.0 ~ 25.0	0.48	11.5	3900	132.0	3.73	.45	113.0	54.0	260
** 4715KL-07W-B30-	R00	48	25.0 ~ 55.2	0.13	6.24	3100	105.0	2.97	.30	74.0	47.0	260
** 4715KL-07W-B40-	R00	48	25.0 ~ 50.4	0.16	7.68	3500	121.0	3.44	.39	97.5	51.0	260
** 4715KL-07W-B50-	R00	48	36.0 ~ 50.0	0.20	9.60	3900	132.0	3.73	.45	113.0	54.0	260

Rotation: Clockwise

Airflow Outlet: Air Out Over Struts

\*1: Average Values in Free Air

\*\* Contact NMB for availability

## General Specifications

### Motor Protection:

Auto Restart/Polarity Protection

### Insulation Resistance:

10M Ω or over with a DC500V Megger

### Dielectric Withstand Voltage: AC 700V 1s

### Allowable Ambient Temperature Range:

-10°C ~ +70°C (Operating)

-40°C ~ +70°C (Storage)

(non-condensing environment)

## Expected Life

### Failure Rate: 10%

25°C 100,000 Hours (E00)

## Material

Casing : Plastic (Black) 94V-0

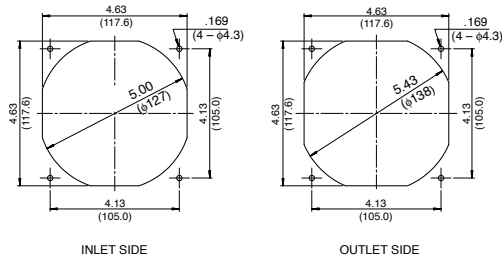
Impeller : Plastic (Black) 94V-0

Bearing : Ball Bearing

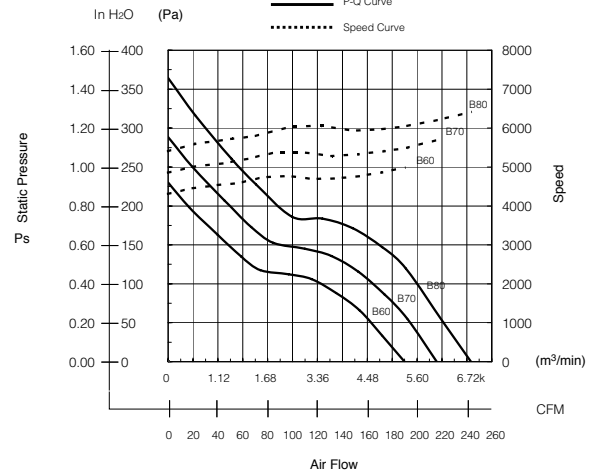
Lead Wire : UL1061, AWG24, +Red, -Black

## Panel Cut-Outs

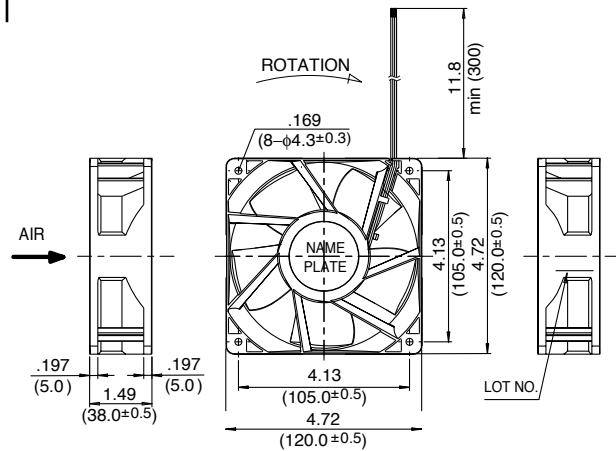
Units:  $\frac{\text{inch}}{\text{(mm)}}$



## Characteristic Curves



## Outline



## Specifications

MODEL	Product No.	Rated Voltage	Operating Voltage	Current	Input Power	Speed	Max. Air Flow		Max. Static Pressure		Noise	Mass
		(V)	(V)	(A) <sup>1</sup>	(W) <sup>1</sup>	(min <sup>-1</sup> ) <sup>1</sup>	CFM <sup>1</sup>	(m <sup>3</sup> /min) <sup>1</sup>	in H <sub>2</sub> O	(Pa) <sup>1</sup>	(dB) <sup>1</sup>	(g)
4715VL-04W-B60-	EXX	12	10.0 ~ 13.8	1.50	18.00	5000	189.9	5.38	0.92	229	59.5	370
4715VL-04W-B70-	EXX	12	10.0 ~ 13.8	2.25	27.00	5700	215.7	6.11	1.15	287	63.0	370
4715VL-04W-B80-	EXX	12	10.0 ~ 12.6	3.00	36.00	6400	243.2	6.89	1.46	363	66.0	370
4715VL-05W-B50-	EXX	24	18.0 ~ 27.6	0.76	18.24	4700	182.5	5.17	0.83	207	55.5	370
4715VL-05W-B60-	EXX	24	18.0 ~ 27.6	0.74	17.76	5000	189.9	5.38	0.92	229	59.5	370
4715VL-05W-B70-	EXX	24	18.0 ~ 27.6	1.04	24.96	5700	215.7	6.11	1.15	287	63.0	370
4715VL-05W-B80-	EXX	24	18.0 ~ 27.6	1.48	35.52	6400	243.2	6.89	1.46	363	66.0	370
4715VL-07W-B50-	EXX	48	40.0 ~ 52.8	0.37	17.80	4700	182.5	5.17	0.83	207	55.5	370
4715VL-07W-B60-	EXX	48	40.0 ~ 55.2	0.45	21.60	5000	189.9	5.38	0.92	229	59.5	370
4715VL-07W-B70-	EXX	48	40.0 ~ 55.2	0.60	28.80	5700	215.7	6.11	1.15	287	63.0	370
4715VL-07W-B80-	EXX	48	40.0 ~ 52.0	0.80	38.40	6400	243.2	6.89	1.46	363	66.0	370

Rotation: Clockwise

Airflow Outlet: Air Out Over Struts

\*1: Average Values in Free Air

## General Specifications

### Motor Protection:

Auto Restart/Polarity Protection

### Insulation Resistance:

10M Ω or over with a DC500V Megger

### Dielectric Withstand Voltage: AC 700V 1s

### Allowable Ambient Temperature Range:

-10°C ~ +70°C (Operating)

-40°C ~ +70°C (Storage)

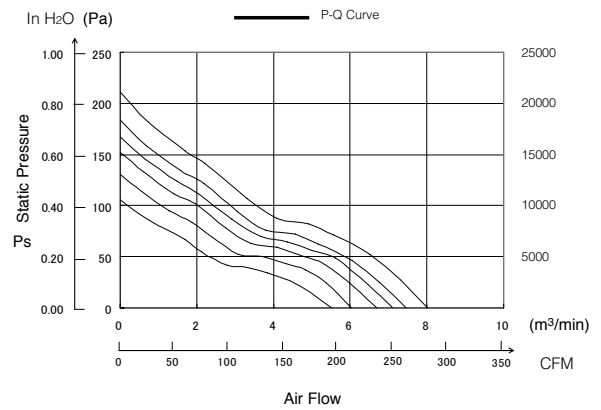
(non-condensing environment)

## Expected Life

### Failure Rate: 10%

25°C 100,000 Hours (D00)

## Characteristic Curves



## Material

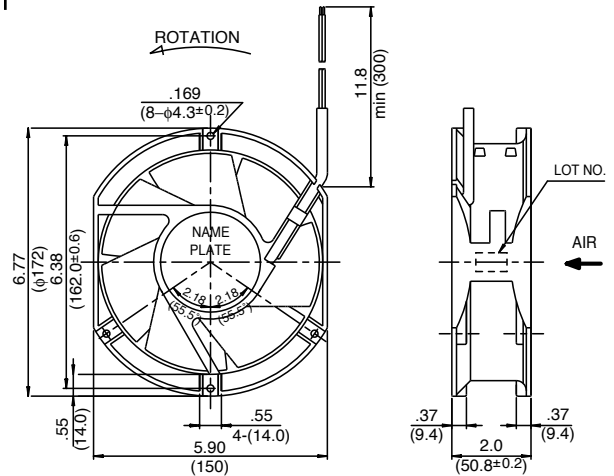
Casing : Plastic (Black) 94V-0

Impeller : Plastic (Black) 94V-0

Bearing : Ball Bearing

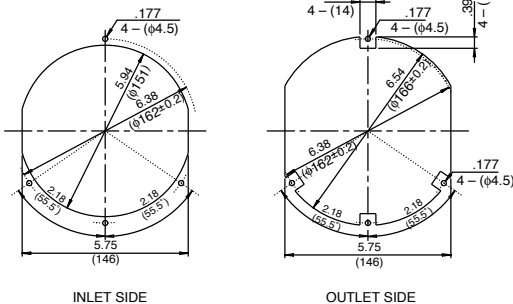
Lead Wire : UL1007, AWG26, +Red, -Black

## Outline



## Panel Cut-Outs

Units:  $\frac{\text{inch}}{\text{mm}}$



## Specifications

MODEL	Product No.	Rated Voltage	Operating Voltage	Current	Input Power	Speed	Max. Air Flow		Max. Static Pressure		Noise	Mass
		(V)	(V)	(A) <sup>*1</sup>	(W) <sup>*1</sup>	(min <sup>-1</sup> ) <sup>*1</sup>	CFM <sup>*1</sup>	(m <sup>3</sup> /min) <sup>*1</sup>	in H <sub>2</sub> O	(Pa) <sup>*1</sup>	(dB) <sup>*1</sup>	(g)
5920VL-07W-B10-	DXX	48	36 ~ 56	0.28	13.44	2550	194.5	5.51	.43	106	51.0	830
5920VL-07W-B20-	DXX	48	36 ~ 56	0.33	15.84	2850	213.2	6.04	.53	131	54.0	830
5920VL-07W-B30-	DXX	48	36 ~ 56	0.37	17.76	3150	236.5	6.70	.61	152	57.0	830
5920VL-07W-B40-	DXX	48	36 ~ 56	0.41	19.68	3350	251.0	7.11	.67	167	59.0	830
5920VL-07W-B50-	DXX	48	36 ~ 56	0.44	21.10	3500	263.3	7.46	.74	184	61.0	830
5920VL-07W-B60-	DXX	48	36 ~ 56	0.52	25.00	3750	283.1	8.02	.85	211	63.0	830

Rotation: Counterclockwise

Airflow Outlet: Air Out Over Struts

\*1: Average Values in Free Air

## Common Specifications

- Vibration Test: ..... Conforms to JIS C 60068-2-6, Amplitude: 1.5mm, Frequency 10 to 55 Hz, 1 hour in each of the X, Y and Z directions.
- Shock Test: ..... Conforms to JIS C 60068-2-27, Acceleration rate: 981 m/s<sup>2</sup>\*, Application time: 6ms once each in the X, Y and Z directions. Note: For the BM4515, BM5115, BM5125 and BM6015 series, the conditions of the shock test are as follows: Acceleration rate 500 m/s<sup>2</sup>, Application time: 11ms once each in the X, Y and Z directions.
- Locked Rotor Protection : .. The motor is protected from burnout in the locked rotor condition for 72 hours, at the rated voltage.
- Polarity Protection : ..... The fans are Reverse Polarity protected at the rated voltage.
- Insulation Class : ..... E class (UL: Class A)
- Auto Restart:..... Most fan models provide current shut-down/auto restart function under locked rotor conditions.

Notes: Additional performance requirements can be determined between manufacturer and customer, based on customer's request.  
Ball bearing fans and blowers may be installed in a horizontal, vertical or angled position

## BM Part Numbering System

BM 51 15 - 04 W - B 3 0 - L 00  
 ① ② ③ ④ ⑤ ⑥ ⑦ ⑧ ⑨ ⑩

- |  |  |   |   |
|--|--|---|---|
| <p>1. Series<br/>BM Series</p> <p>2. Size<br/>45: 45mm<br/>51: 51mm<br/>60: 60mm</p> <p>3. Thickness<br/>15: 15mm<br/>25: 25mm</p> <p>4. Input Voltage<br/>O: Standard Current<br/>C: Special Current<br/>D~Z: Special Current<br/>(A.B.O. are not used)</p> | <p>5. Termination<br/>Lead Wire</p> <p>6. Bearing<br/>B: Ball Bearing<br/>S: Sleeve Bearing</p> <p>7. Speed<br/>1&lt;2&lt;3&lt;4&lt;5<br/>low high</p> | <p>8. Special Control Function<br/>0: Standard Type<br/>9: Sensor Type<br/>8: 2-Speed Type<br/>7: Temperature Detecting Variable Speed Type/PWM Control Type<br/>6: Temperature Detecting Variable Speed Type/Sensor Type<br/>5: 2-Speed Type/Sensor Type</p> <p>9. Classification<br/>L-Standard Model/Rib Type<br/>T-Value Model/Rib Type</p> | <p>10. Individual Specifications<br/>Standard Type<br/>00: Standard<br/>01~99: Custom<br/>Sensor Type<br/>00: Locked Rotor Alarm Signal (Standard Type)<br/>01~49: Locked Rotor Alarm Signal (Custom Type)<br/>50: Tachometer Signal (Standard Type)<br/>51~99: Tachometer Signal (Custom Type)</p> |
|--|--|---|---|

## BG Part Numbering System

BG 07 03 - B 04 - 4 - 000 - 00  
 ① ② ③ ④ ⑤ ⑥ ⑦ ⑧

- |  |  |  |  |
|--|--|--|--|
| <p>1. Series<br/>BG Series</p> <p>2. Size<br/>07: 75mm<br/>08: 80mm<br/>09: 95mm<br/>10: 100mm<br/>12: 120mm</p> <p>3. Thickness<br/>01: 18mm<br/>02: 25mm<br/>03: 30~33mm</p> | <p>4. Bearing<br/>B: Ball Bearing<br/>S: Sleeve Bearing</p> <p>5. Input Voltage<br/>O: Standard Current<br/>C: Special Current<br/>D~Z: Special Current<br/>(A.B.O. are not used)<br/>1: 5V 5: 24V<br/>2: 6V 6: 36V<br/>3: 9V 7: 48V<br/>4: 12V 9: Other</p> | <p>6. Speed<br/>1&lt;2&lt;3&lt;4&lt;5<br/>low high</p> <p>7. Special Control Function<br/>0 0 0<br/>A B C<br/>A: Special Control Function<br/>O: Fix Speed Type<br/>2: 2-Speed Type<br/>V: Temperature Detecting Variable Speed Type<br/>P: PWM Control Type</p> | <p>B: Thermistor Mounting Position<br/>O: No Thermistor<br/>T: Thermistor On PCB<br/>C: Output Signal<br/>O: No Signal<br/>L: Locked Rotor Alarm Signal<br/>S: Tachometer Signal</p> <p>8. Product Number<br/>00: Standard<br/>01~ : Customized Standard<br/>T0: Standard Value<br/>T1~ : Customized Value</p> |
|--|--|--|--|

**General Specifications**

- Motor Protection:**  
Auto Restart/Polarity Protection
- Insulation Resistance:**  
10M Ω or over with a DC500V Megger
- Dielectric Withstand Voltage:** AC 700V 1s
- Allowable Ambient Temperature Range:**  
-10°C ~ +60°C (Operating)  
-40°C ~ +70°C (Storage)  
(non-condensing environment)

**Expected Life**

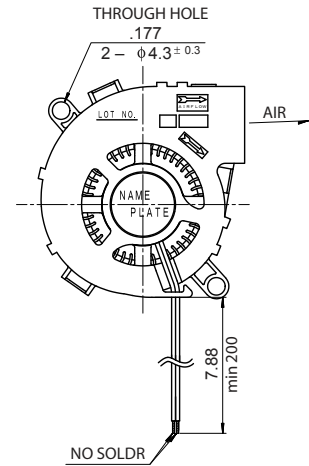
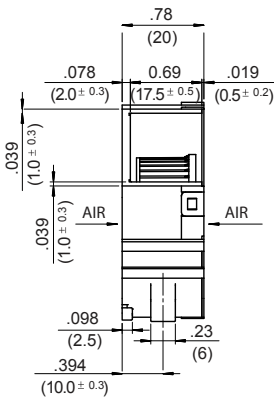
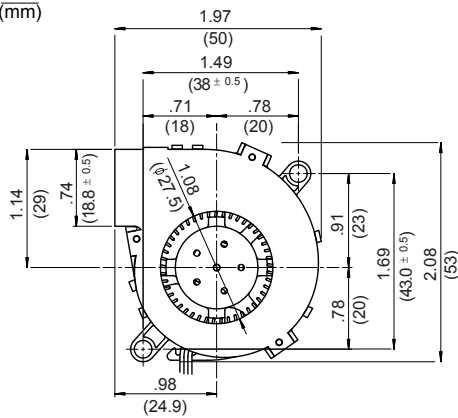
**Failure Rate: 10%**  
25°C 50,000 Hours (L00)

**Material**

- Casing : Plastic (Black) 94V-0
- Impeller : Plastic (Black) 94V-0
- Bearing : Ball Bearing
- Lead Wire : UL1061, AWG26, +Red, -Black

**Outline**

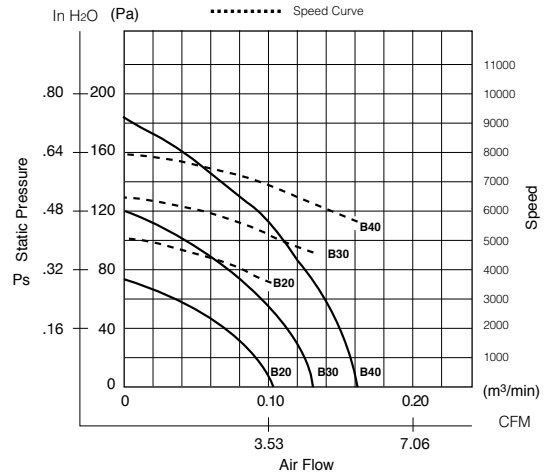
Units:  $\frac{\text{inch}}{\text{(mm)}}$



**Specifications**

MODEL	Product No.	Rated Voltage	Operating Voltage	Current	Input Power	Speed	Max. Air Flow		Max. Static Pressure		Noise	Mass
		(V)	(V)	(A) <sup>*1</sup>	(W) <sup>*1</sup>	(min <sup>-1</sup> ) <sup>*1</sup>	CFM <sup>*1</sup>	(m <sup>3</sup> /min) <sup>*1</sup>	in H <sub>2</sub> O	(Pa) <sup>*1</sup>	(dB) <sup>*1</sup>	(g)
BM5020-01W-B30-	L00	5	4.5 ~ 5.5	0.34	1.70	4600	4.6	0.13	.50	124	27.0	30
BM5020-04W-B20-	L00	12	4.5 ~ 13.8	0.07	0.84	3600	3.5	0.10	.30	75	20.0	30
BM5020-04W-B30-	L00	24	4.5 ~ 13.8	0.12	1.44	4600	4.6	0.13	.50	124	27.0	30
BM5020-04W-B40-	L00	24	4.5 ~ 13.8	0.18	2.16	5600	5.6	0.16	.74	184	32.0	30
BM5020-05W-B40-	L00	24	12.0 ~ 25.2	0.08	1.92	5600	5.6	0.16	.74	184	32.0	30

**Characteristic Curves**





## General Specifications

### Motor Protection:

Auto Restart/Polarity Protection

### Insulation Resistance:

10M Ω or over with a DC500V Megger

### Dielectric Withstand Voltage: AC 700V 1s

### Allowable Ambient Temperature Range:

-10°C ~ +70°C (Operating)

-40°C ~ +70°C (Storage)

(non-condensing environment)

## Expected Life

### Failure Rate: 10%

25°C 70,000 Hours (00)

## Material

Casing : Plastic (Black) 94V-0

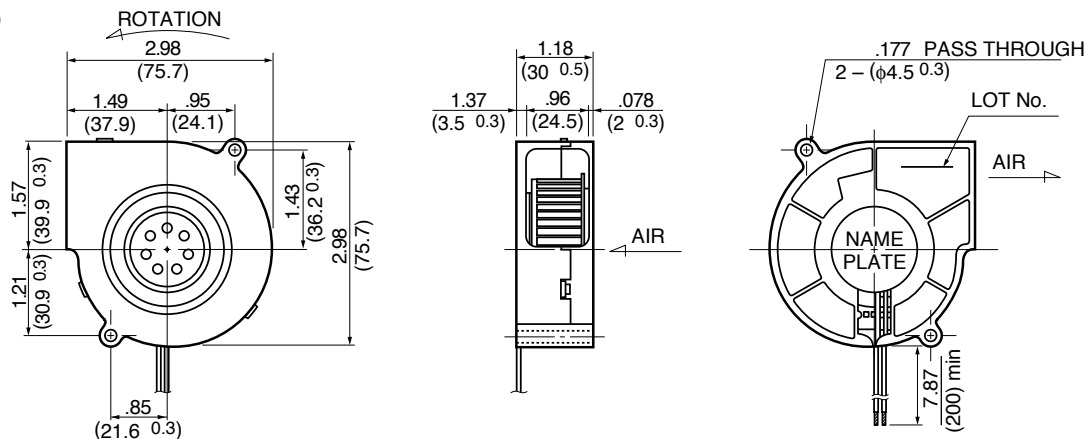
Impeller : Plastic (Black) 94V-0

Bearing : Ball Bearing

Lead Wire : UL1007, AWG26, +Red, -Black

## Outline

Units:  $\frac{\text{inch}}{\text{mm}}$



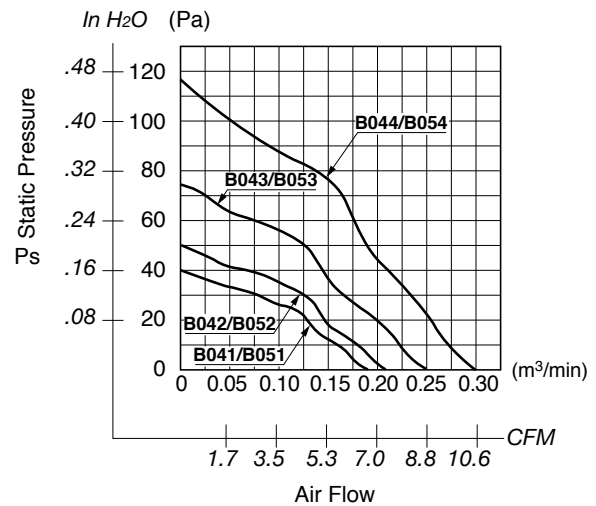
## Specifications

MODEL	Product No.	Rated Voltage	Operating Voltage	Current	Input Power	Speed	Max. Air Flow		Max. Static Pressure		Noise	Mass
		(V)	(V)	(A) <sup>*1</sup>	(W) <sup>*1</sup>	(min <sup>-1</sup> ) <sup>*1</sup>	CFM <sup>*1</sup>	(m <sup>3</sup> /min) <sup>*1</sup>	in H <sub>2</sub> O	(Pa) <sup>*1</sup>	(dB) <sup>*1</sup>	(g)
BG0703-B041-000-	X0	12	6 ~ 13.8	0.10	1.20	2000	6.7	0.19	.16	40	28.0	90
BG0703-B042-000-	X0	12	6 ~ 13.8	0.12	1.44	2200	7.4	0.21	.20	50	29.5	90
BG0703-B043-000-	X0	12	6 ~ 13.8	0.18	2.16	2550	8.8	0.25	.30	75	34.5	90
BG0703-B044-000-	X0	12	6 ~ 13.0	0.29	3.48	3000	10.6	0.30	.44	110	38.5	90
BG0703-B051-000-	X0	24	10 ~ 27.6	0.06	1.44	2000	6.7	0.19	.16	40	28.0	90
BG0703-B052-000-	X0	24	10 ~ 27.6	0.07	1.68	2200	7.4	0.21	.20	50	29.5	90
BG0703-B053-000-	X0	24	10 ~ 27.6	0.09	2.16	2550	8.8	0.25	.30	75	34.5	90
BG0703-B054-000-	X0	24	10 ~ 26.0	0.15	3.60	3000	10.6	0.30	.44	110	38.5	90

Rotation: Counterclockwise

\*1: Average Values in Free Air

## Characteristic Curves



### General Specifications

- Motor Protection:**  
Auto Restart/Polarity Protection
- Insulation Resistance:**  
10M Ω or over with a DC500V Megger
- Dielectric Withstand Voltage:** AC 700V 1s
- Allowable Ambient Temperature Range:**  
-10°C ~ +60°C (Operating)  
-40°C ~ +70°C (Storage)  
(non-condensing environment)

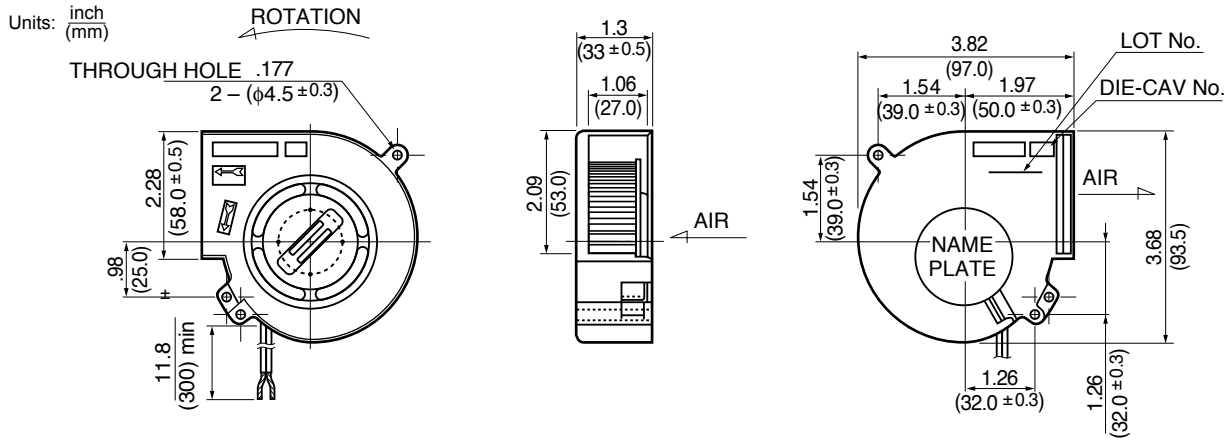
### Expected Life

**Failure Rate: 10%**  
25°C 100,000 Hours (00)

### Material

- Casing : Plastic (Black) 94V-0
- Impeller : Plastic (Black) 94V-0
- Bearing : Ball Bearing
- Lead Wire : UL1007, AWG26, +Red, -Black

### Outline



### Specifications

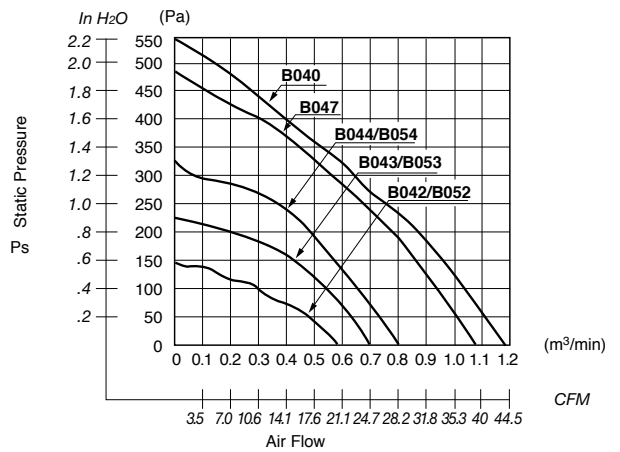
MODEL	Product No.	Rated Voltage	Operating Voltage	Current	Input Power	Speed	Max. Air Flow		Max. Static Pressure		Noise	Mass
		(V)	(V)	(A) <sup>*1</sup>	(W) <sup>*1</sup>	(min <sup>-1</sup> ) <sup>*1</sup>	CFM <sup>*1</sup>	(m <sup>3</sup> /min) <sup>*1</sup>	in H <sub>2</sub> O	(Pa) <sup>*1</sup>	(dB) <sup>*1</sup>	(g)
BG0903-B042-000-	00	12	8 ~ 13.8	0.40	4.80	2700	20.5	0.58	.61	152	47.5	210
BG0903-B043-000-	00	12	8 ~ 13.8	0.64	7.68	3200	24.7	0.70	.90	225	51.5	210
BG0903-B044-000-	00	12	8 ~ 12.6	1.03	12.40	3700	28.6	0.81	1.4	342	54.5	210
BG0903-B052-000-	00	24	10 ~ 27.6	0.21	5.04	2700	20.5	0.58	.61	152	47.5	210
BG0903-B053-000-	00	24	10 ~ 27.6	0.33	7.92	3200	24.7	0.70	.90	225	51.5	210
BG0903-B054-000-	00	24	10 ~ 25.0	0.49	11.80	3700	28.6	0.81	1.4	342	54.5	210
<b>HIGH SPEED</b>												
** BG0903-B040-000-	00	12	10.8 ~ 13.6	2.4	28.90	5700	42.0	1.19	2.2	549	65	210
** BG0903-B047-000-	00	12	10.8 ~ 12.6	1.6	19.20	5200	38.1	1.08	1.9	482	-	210

Rotation: Counterclockwise

\*1: Average Values in Free Air

\*\* Contact NMB for availability

### Characteristic Curves



## General Specifications

### Motor Protection:

Auto Restart/Polarity Protection

### Insulation Resistance:

10M Ω or over with a DC500V Megger

### Dielectric Withstand Voltage: AC 700V 1s

### Allowable Ambient Temperature Range:

-10°C ~ +60°C (Operating)

-40°C ~ +70°C (Storage)

(non-condensing environment)

## Expected Life

### Failure Rate: 10%

25°C 100,000 Hours (00)

## Material

Casing : Plastic (Black) 94V-0

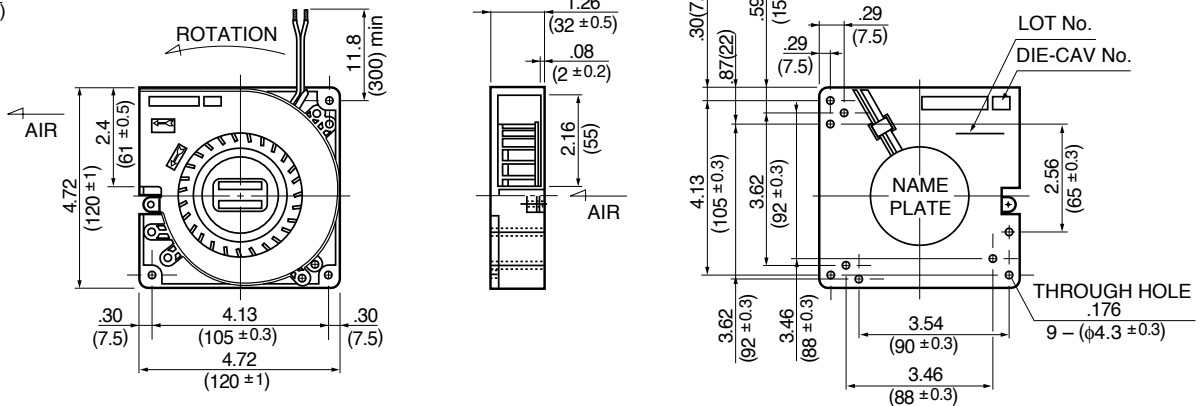
Impeller : Plastic (Black) 94V-0

Bearing : Ball Bearing

Lead Wire : UL1007, AWG26, +Red, -Black

## Outline

Units:  $\frac{\text{inch}}{\text{mm}}$



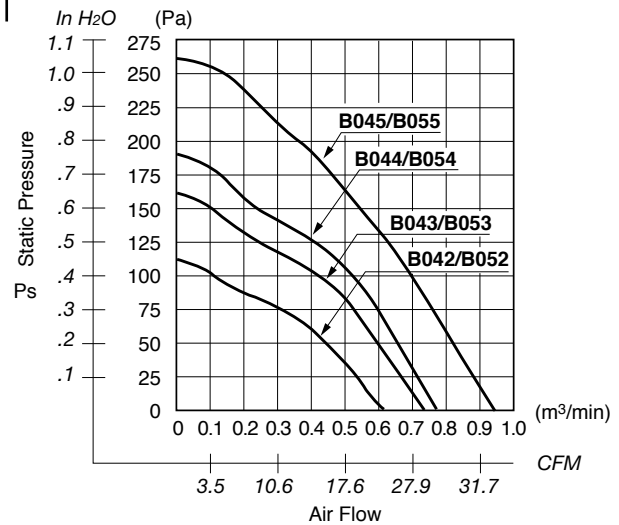
## Specifications

MODEL	Product No.	Rated Voltage	Operating Voltage	Current	Input Power	Speed	Max. Air Flow		Max. Static Pressure		Noise	Mass
		(V)	(V)	(A) <sup>*1</sup>	(W) <sup>*1</sup>	(min <sup>-1</sup> ) <sup>*1</sup>	CFM <sup>*1</sup>	(m <sup>3</sup> /min) <sup>*1</sup>	in H <sub>2</sub> O	(Pa) <sup>*1</sup>	(dB) <sup>*1</sup>	(g)
BG1203-B042-000-	00	12	6 ~ 13.8	0.30	3.60	1800	22.2	0.63	.40	100	41.5	270
BG1203-B043-000-	00	12	6 ~ 13.8	0.48	5.78	2100	26.1	0.74	.58	145	46.5	270
BG1203-B044-000-	00	12	6 ~ 13.8	0.65	7.80	2250	28.2	0.80	.70	175	48.5	270
BG1203-B045-000-	00	12	6 ~ 13.8	0.93	11.16	2650	33.2	0.94	1.04	260	54.0	270
BG1203-B052-000-	00	24	12 ~ 27.6	0.17	4.08	1800	22.2	0.63	.40	100	41.5	270
BG1203-B053-000-	00	24	12 ~ 27.6	0.25	6.00	2100	26.1	0.74	.56	145	46.5	270
BG1203-B054-000-	00	24	12 ~ 27.6	0.30	7.20	2250	28.2	0.80	.70	175	48.5	270
BG1203-B055-000-	00	24	12 ~ 25.2	0.48	11.52	2650	33.2	0.94	1.04	260	54.0	270

Rotation: Counterclockwise

\*1: Average Values in Free Air

## Characteristic Curves



A series of horizontal dotted lines providing a space for writing notes.

## Common Specifications

- Operating Voltage:.....Rated voltage +/- 10%
- Noise: .....Measured at 1 meter from the side of the fan at the rated voltage
- Vibration Test:..... JIS C 60068-2-6
- Shock Test:..... JIS C 60068-2-27
- Insulation Class: ..... E class (UL: Class A)
- Protection: ..... Motor burnout is prevented by the impedance protection system or the thermal protection system.
- Impedance Protection System:..... The motor coil impedance limits motor temperature within the insulation class specification.
- Thermal Protection System: ..... The coil includes a thermal cut-out to limit motor temperature within the insulation class specification.

Notes: Additional performance requirements can be determined between manufacturer and customer, based on customer's request. Ball bearing fans may be installed in a horizontal, vertical or angled position.

## Part Numbering System

$\frac{47}{1}$   $\frac{15}{2}$   $\frac{P}{3}$   $\frac{S}{4}$  -  $\frac{12}{5}$   $\frac{T}{6}$  -  $\frac{B}{7}$   $\frac{2}{8}$   $\frac{0}{9}$  -  $\frac{A}{10}$   $\frac{00}{11}$

- |   |  |   |  |
|---|--|---|--|
| <p><b>1. Frame Size</b><br/>24: 60mm<br/>31: 80mm<br/>36: 92mm<br/>47: 119mm<br/>59: 150mm</p> <p><b>2. Frame Thickness</b><br/>10: 25mm<br/>12: 30mm<br/>15: 38mm</p> <p><b>3. Series</b><br/>P Series<br/>M Series<br/>F Series</p> | <p><b>4. Motor Function</b><br/>S: Shaded Pole<br/>C: Capacitor Run</p> <p><b>5. Input Voltage</b><br/>100V Class<br/>10: 100V<br/>12: 115V<br/>200V Class<br/>20: 200V<br/>22: 220V<br/>23: 230V<br/>24: 240V</p> | <p><b>6. Termination</b><br/>W: Lead Wires<br/>T: Terminal</p> <p><b>7. Bearing</b><br/>B: Ball Bearing</p> <p><b>8. Speed</b><br/>1&lt;2&lt;3&lt;4&lt;5<br/>low high</p> <p><b>9. Protection</b><br/>0: Impedance Protected<br/>A: Thermal Protected<br/>(including 5915PC B30 only)</p> | <p><b>10. Product Number</b><br/>A: Standard 115V, 230V &amp; 240V<br/>B: Standard 100V, 200V &amp; 220V<br/>D: Custom Casing 115V-230V<br/>K: Frameless</p> <p><b>11. Individual Specification</b><br/>00: Standard<br/>01~99: Custom</p> |
|---|--|---|--|

$\frac{47}{1}$   $\frac{15}{2}$   $\frac{T}{3}$   $\frac{S}{4}$  -  $\frac{23}{5}$   $\frac{T}{6}$  -  $\frac{B}{7}$   $\frac{50}{8}$  -  $\frac{A}{9}$   $\frac{M}{10}$   $\frac{0}{11}$

$\frac{59}{1}$   $\frac{15}{2}$   $\frac{P}{3}$   $\frac{C}{4}$  -  $\frac{20}{5}$   $\frac{T}{6}$  -  $\frac{B}{7}$   $\frac{30}{8}$  -  $\frac{S}{9}$   $\frac{M}{10}$   $\frac{0}{11}$

- |   |  |  |  |
|---|--|--|--|
| <p><b>1. Frame Size</b><br/>24: 60mm<br/>31: 80mm<br/>36: 92mm<br/>47: 119mm<br/>59: 150mm</p> <p><b>2. Frame Thickness</b><br/>10: 25mm<br/>12: 30mm<br/>15: 38mm<br/>20: 51mm</p> | <p><b>3. Series</b><br/>H: Plastic Blades<br/>M: Plastic Blades<br/>P: Plastic/Metal Blades<br/>T: Metal Blades</p> <p><b>4. Motor Function</b><br/>S: Shaded Pole<br/>C: Capacitor Run</p> <p><b>5. Input Voltage</b><br/>10: 100V<br/>12: 115V<br/>20: 200V<br/>22: 220V<br/>23: 230V<br/>24: 240V</p> | <p><b>6. Input</b><br/>T: Terminal<br/>W: Lead Wires</p> <p><b>7. Bearing</b><br/>B: Ball Bearing</p> <p><b>8. Speed</b><br/>10&lt;20&lt;30&lt;40&lt;50<br/>low high<br/>X2 Dual Input</p> | <p><b>9. Input Voltage Class</b><br/>A: 115V / 230V<br/>B: 100V / 200V<br/>S: Metal Blades</p> <p><b>10. Potting Method</b><br/>M: Potted<br/>O: Non-Potted</p> <p><b>11. Product Number</b><br/>0: Standard<br/>1~: Special</p> |
|---|--|--|--|

## General Specifications

**Motor Structure:** Shaded Pole Induction Motor  
**Motor Protection:** Impedance Protection  
**Insulation Resistance:**  
 10M Ω or over with a DC500V Megger  
**Dielectric Withstand Voltage:** AC 700V 1s  
**Allowable Ambient Temperature Range:**  
 -10°C ~ +70°C (Operating)  
 -40°C ~ +70°C (Storage)  
 (non-condensing environment)

## Expected Life

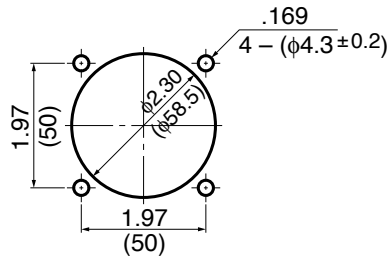
**Failure Rate: 10%**  
 25°C 50,000 Hours

## Material

**Casing :** Aluminum  
**Impeller :** Polycarbonate (Glass Fiber-Containing)  
**Bearing :** Ball Bearing  
**Lead Wire :** UL3266, CSA CL 1252, AWG22

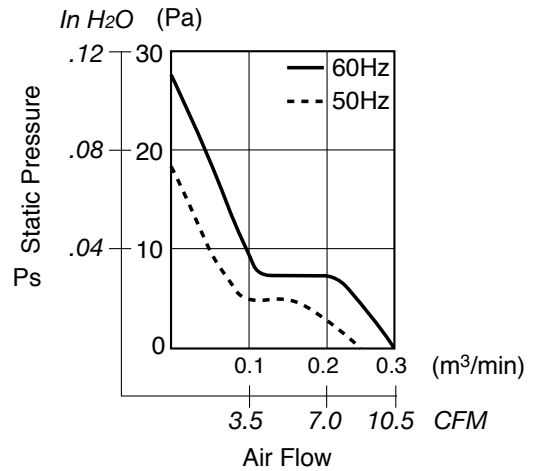
## Panel Cut-Outs

Units:  $\frac{\text{inch}}{\text{mm}}$

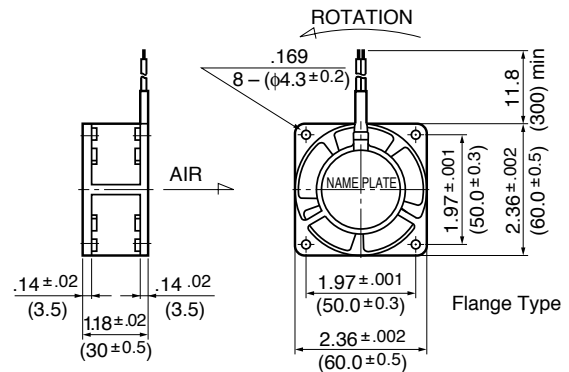


INLET SIDE / OUTLET SIDE

## Characteristic Curves



## Outline



## Specifications

MODEL	Rated Voltage	Frequency	Starting Voltage	Current	Input Power	Speed	Max. Air Flow		Max. Static Pressure		Noise	Mass
	(V)	(Hz)	(V)	(A) <sup>*1</sup>	(W) <sup>*10%</sup> <sup>-20%</sup>	(min <sup>-1</sup> ) <sup>*2</sup>	CFM	(m <sup>3</sup> /min) <sup>*2</sup>	in H <sub>2</sub> O	(Pa) <sup>*2</sup>	(dB) <sup>*2</sup>	(g)
2412PS-10W-B30-A00	100	50	65	0.080	6.0	2000	7.0	0.20	.05	13.7	28	140
	100	60	65	0.070	5.0	2600	9.1	0.26	.09	22.6	29	140
2412PS-12W-B30-A00	115	50	65	0.070	4.5	2000	7.0	0.20	.05	13.7	28	140
	115	60	65	0.060	4.0	2600	9.1	0.26	.09	22.6	29	140

Rotation: Counterclockwise

Airflow Outlet: Air out over struts

\*1: Maximum Values in Free Air

\*2: Average Values in Free Air

\*3: Minimum Values in Free Air

### General Specifications

**Motor Structure:** Shaded Pole Induction Motor  
**Motor Protection:** Impedance Protection  
**Insulation Resistance:**  
 10M Ω or over with a DC500V Megger  
**Dielectric Withstand Voltage:** AC 700V 1s  
**Allowable Ambient Temperature Range:**  
 -10°C ~ +70°C (Operating)  
 -40°C ~ +70°C (Storage)  
 (non-condensing environment)

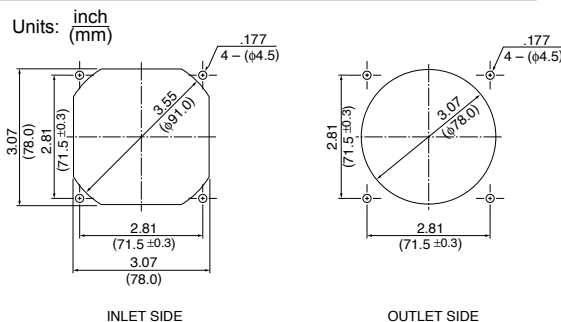
### Expected Life

**Failure Rate: 10%**  
 25°C 100,000 Hours

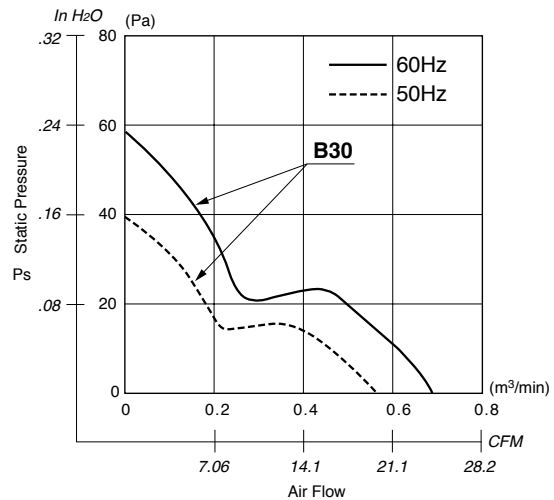
### Material

**Casing :** Aluminum  
**Impeller :** Polycarbonate (Glass Fiber-Containing)  
**Bearing :** Ball Bearing  
**Lead Wire :** UL3266, CSA CL 1252, AWG22

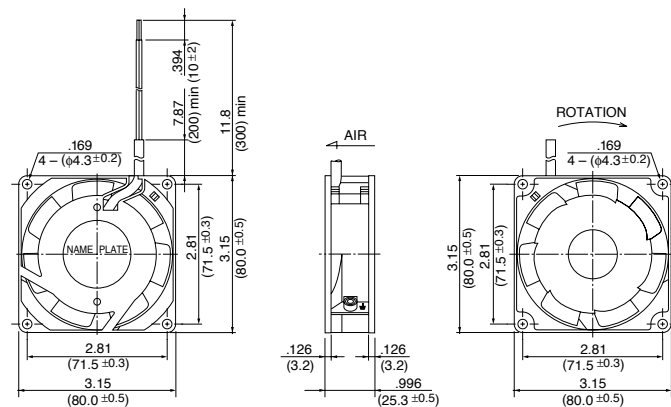
### Panel Cut-Outs



### Characteristic Curves



### Outline



### Specifications

MODEL	Rated Voltage	Frequency	Starting Voltage	Current	Input Power	Speed	Max. Air Flow		Max. Static Pressure		Noise	Mass
	(V)	(Hz)	(V)	(A) <sup>*1</sup>	(W) <sup>*1</sup>	(min <sup>-1</sup> ) <sup>*1</sup>	CFM	(m <sup>3</sup> /min) <sup>*1</sup>	in H <sub>2</sub> O	(Pa) <sup>*1</sup>	(dB) <sup>*1</sup>	(g)
** 3110MS-20W-B30-B00	200	50	130	0.060	7.0	2500	20.1	0.57	0.15	39.0	24	240
** 3110MS-20W-B30-B00	200	60	130	0.050	6.0	3000	24.0	0.68	0.22	55.0	31	240
** 3110MS-22W-B30-B00	220	50	165	0.055	7.5	2500	20.1	0.57	0.15	39.0	24	240
** 3110MS-22W-B30-B00	220	60	165	0.045	6.5	3000	24.0	0.68	0.22	55.0	31	240
3110MS-23W-B30-A00	230	50	180	0.050	7.5	2500	20.1	0.57	0.15	39.0	24	240
3110MS-23W-B30-A00	230	60	180	0.045	6.5	3000	24.0	0.68	0.22	55.0	31	240
** 3110MS-24W-B30-A00	240	50	180	0.050	7.5	2500	20.1	0.57	0.15	39.0	24	240
** 3110MS-24W-B30-A00	240	60	180	0.045	6.5	3000	24.0	0.68	0.22	55.0	31	240

Rotation: Counterclockwise

Airflow Outlet: Air Out Over Struts

\*1: Maximum Values in Free Air

\*\* Contact NMB for Availability

\*2: Average Values in Free Air

\*3: Minimum Values in Free Air

## General Specifications

**Motor Structure:** Shaded Pole Induction Motor  
**Motor Protection:** Impedance Protection  
**Insulation Resistance:**  
 10M Ω or over with a DC500V Megger  
**Dielectric Withstand Voltage:** AC 700V 1s  
**Allowable Ambient Temperature Range:**  
 -10°C ~ +70°C (Operating)  
 -40°C ~ +70°C (Storage)  
 (non-condensing environment)

## Expected Life

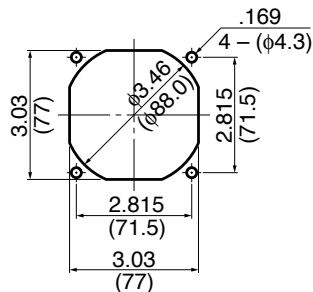
**Failure Rate: 10%**  
 25°C 50,000 Hours

## Material

**Casing :** Aluminum  
**Impeller :** Polycarbonate (Glass Fiber-Containing)  
**Bearing :** Ball Bearing  
**Lead Wire :** UL3266, CSA CL 1252, AWG22

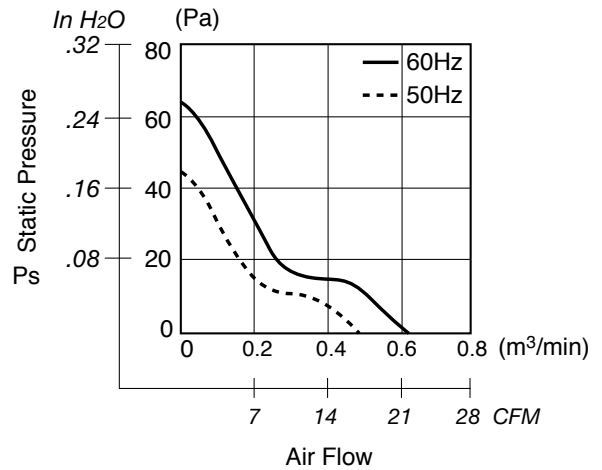
## Panel Cut-Outs

Units:  $\frac{\text{inch}}{\text{mm}}$

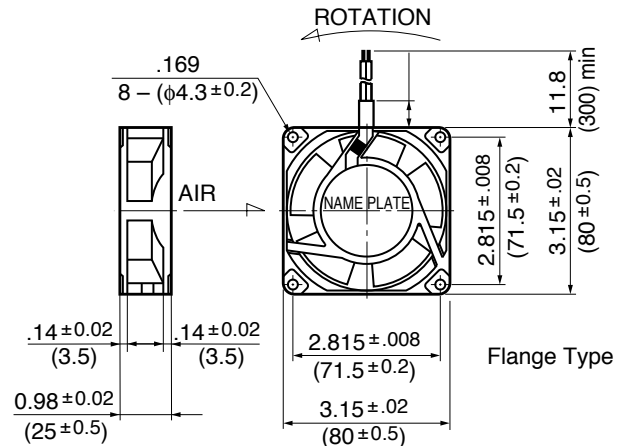


INLET SIDE / OUTLET SIDE

## Characteristic Curves



## Outline



## Specifications

MODEL	Rated Voltage	Frequency	Starting Voltage	Current	Input Power	Speed	Max. Air Flow		Max. Static Pressure		Noise	Mass
	(V)	(Hz)	(V)	(A) <sup>1</sup>	(W) <sup>10% 20%</sup>	(min <sup>-1</sup> ) <sup>3</sup>	CFM	(m <sup>3</sup> /min) <sup>3</sup>	in H <sub>2</sub> O	(Pa) <sup>3</sup>	(dB) <sup>2</sup>	(g)
3110PS-10W-B30-A00	100	50	65	0.090	6.0	2600	16.2	0.46	.15	39.2	28	220
	100	60	65	0.080	5.0	3100	19.7	0.56	.21	53.9	33	220
3110PS-12W-B30-A00	115	50	65	0.085	6.0	2600	16.2	0.46	.15	39.2	28	220
	115	60	65	0.075	5.0	3100	19.7	0.56	.21	53.9	33	220

Rotation: Counterclockwise

Airflow Outlet: Air Out Over Struts

\*1: Maximum Values in Free Air

\*2: Average Values in Free Air

\*3: Minimum Values in Free Air



## General Specifications

**Motor Structure:** Shaded Pole Induction Motor  
**Motor Protection:** Impedance Protection  
**Insulation Resistance:**  
 10M Ω or over with a DC500V Megger  
**Dielectric Withstand Voltage:** AC 700V 1s  
**Allowable Ambient Temperature Range:**  
 -10°C ~ +70°C (Operating)  
 -40°C ~ +70°C (Storage)  
 (non-condensing environment)

## Expected Life

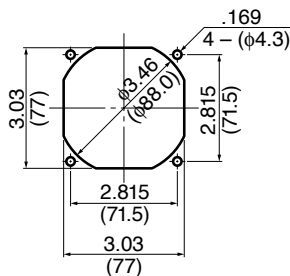
**Failure Rate: 10%**  
 25°C 50,000 Hours

## Material

**Casing** : Aluminum  
**Impeller** : UL94V-O Reinforced Plastic  
**Bearing** : Ball Bearing  
**Lead Wire** : AWG22, UL3266, CSA CL1252  
**or Terminal** : Faston #110 or equivalent

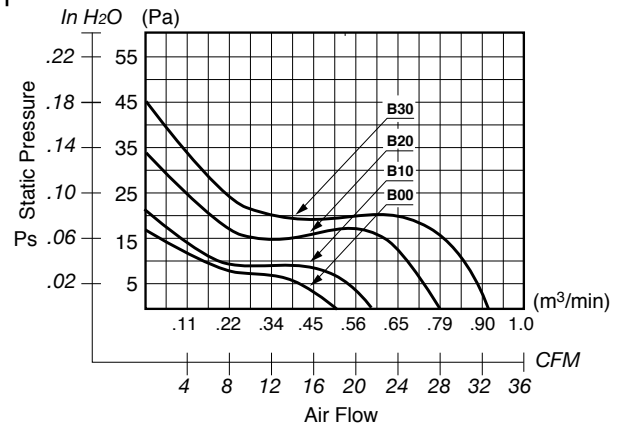
## Panel Cut-Outs

Units:  $\frac{\text{inch}}{\text{mm}}$

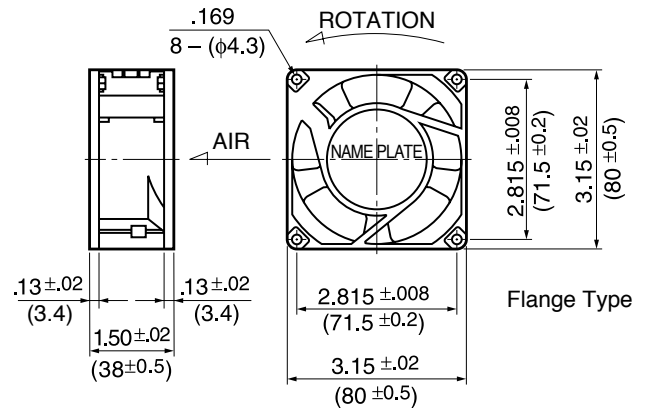


INLET SIDE / OUTLET SIDE

## Characteristic Curves



## Outline



## Specifications

MODEL	Rated Voltage	Frequency	Starting Voltage	Current	Input Power	Speed	Max. Air Flow		Max. Static Pressure		Noise	Mass
	(V)	(Hz)	(V)	(A) <sup>*1</sup>	(W) <sup>*1</sup>	(min <sup>-1</sup> ) <sup>*1</sup>	CFM	(m <sup>3</sup> /min) <sup>*1</sup>	in H <sub>2</sub> O	(Pa) <sup>*1</sup>	(dB) <sup>*1</sup>	(g)
3115FS-12T-B00-A00	115	60	75	0.045	4.0	1850	18.0	0.51	.07	17.5	31	340
3115FS-12T-B10-A00	115	60	75	0.087	6.5	2100	22.0	0.62	.09	22.5	36	340
3115FS-12T-B20-A00	115	60	75	0.090	7.5	2700	27.0	0.76	.13	32.5	40	340
3115FS-12T-B30-A00	115	60	75	0.100	8.5	3250	32.0	0.90	.18	45.0	44	340
3115FS-23T-B10-A00	230	60	175	0.050	6.5	2050	20.0	0.57	.09	22.5	35	340
3115FS-23T-B20-A00	230	60	175	0.060	7.5	2750	28.0	0.79	.13	32.5	40	340
3115FS-23T-B30-A00	230	60	175	0.065	8.0	3250	33.0	0.93	.18	45.0	44	340

Rotation: Counterclockwise

Airflow Outlet: Air In Over Struts

\*1: Maximum Values in Free Air

\*2: Average Values in Free Air

\*3: Minimum Values in Free Air

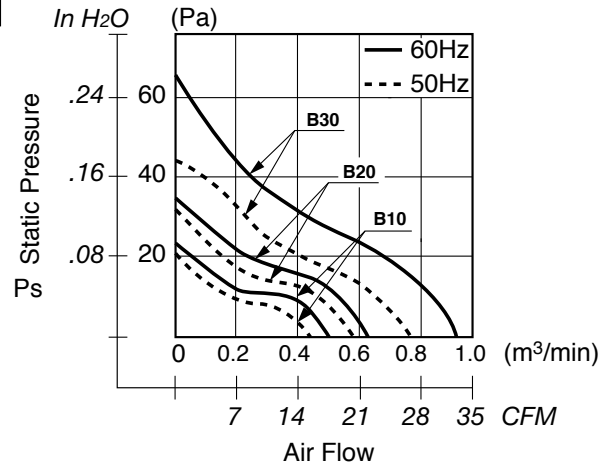
**General Specifications**

Motor Structure: Shaded Pole Induction Motor  
 Motor Protection: Impedance Protection  
 Insulation Resistance:  
 10M Ω or over with a DC500V Megger  
 Dielectric Withstand Voltage: AC 700V 1s  
 Allowable Ambient Temperature Range:  
 -10°C ~ +70°C (Operating)  
 -40°C ~ +70°C (Storage)  
 (non-condensing environment)

**Expected Life**

Failure Rate: 10%  
 25°C 50,000 Hours

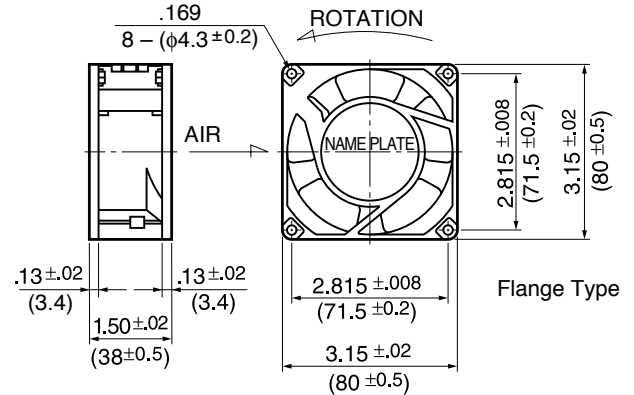
**Characteristic Curves**



**Material**

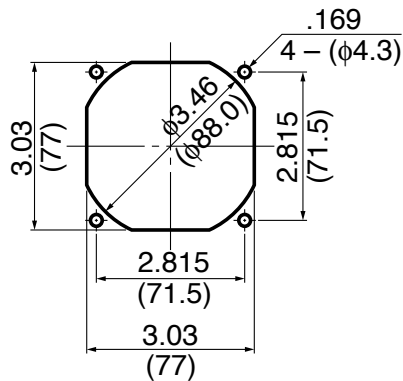
Casing : Aluminum  
 Impeller : Polycarbonate  
 (Glass Fiber-Containing)  
 Bearing : Ball Bearing  
 Lead Wire : AWG22, UL3266, CSA CL1252  
 or Terminal : Faston #110 or equivalent

**Outline**



**Panel Cut-Outs**

Units:  $\frac{\text{inch}}{\text{mm}}$



INLET SIDE / OUTLET SIDE

## Specifications

MODEL	Rated Voltage	Frequency	Starting Voltage	Current	Input Power	Speed	Max. Air Flow		Max. Static Pressure		Noise	Mass
	(V)	(Hz)	(V)	(A) <sup>*1</sup>	(W) <sup>+10% -20%</sup>	(min <sup>-1</sup> ) <sup>*3</sup>	CFM	(m <sup>3</sup> /min) <sup>*3</sup>	in H <sub>2</sub> O	(Pa) <sup>*3</sup>	(dB) <sup>*2</sup>	(g)
** 3115PS-10T-B30-B00	100	50	65	0.170	9.0	2700	26.5	0.75	.14	34.3	33.0	270
	100	60	65	0.120	7.0	3200	32.0	0.90	.20	49.0	38.0	270
3115PS-12T-B30-A00	115	50	75	0.140	9.0	2700	26.5	0.75	.14	34.3	33.0	270
	115	60	75	0.110	7.0	3200	32.0	0.90	.20	49.0	38.0	270
** 3115PS-20T-B30-B00	200	50	130	0.080	9.0	2700	26.5	0.75	.14	34.3	33.0	270
	200	60	130	0.060	7.0	3200	32.0	0.90	.20	49.0	38.0	270
** 3115PS-22T-B30-B00	220	50	150	0.070	9.0	2700	26.5	0.75	.14	34.3	33.0	270
	220	60	150	0.060	7.0	3200	32.0	0.90	.20	49.0	38.0	270
3115PS-23T-B30-A00	230	50	150	0.070	10.0	2700	26.5	0.75	.14	34.3	33.0	270
	230	60	150	0.055	8.0	3200	32.0	0.90	.20	49.0	38.0	270
** 3115PS-24T-B30-A00	240	50	150	0.075	12.0	2700	26.5	0.75	.14	34.3	33.0	270
	240	60	150	0.060	9.0	3200	32.0	0.90	.20	49.0	38.0	270
** 3115PS-10T-B20-B00	100	50	65	0.080	4.5	2100	21.0	0.60	.10	24.5	29.0	270
	100	60	65	0.070	4.0	2300	24.0	0.68	.12	29.4	32.0	270
3115PS-12T-B20-A00	115	50	75	0.080	5.0	2100	21.0	0.60	.10	24.5	29.0	270
	115	60	75	0.070	4.5	2300	24.0	0.68	.12	29.4	32.0	270
** 3115PS-20T-B20-B00	200	50	130	0.040	4.5	2100	21.0	0.60	.10	24.5	29.0	270
	200	60	160	0.035	4.0	2300	24.0	0.68	.13	31.3	32.0	270
** 3115PS-22T-B20-B00	220	50	165	0.045	6.0	2200	22.0	0.63	.10	24.5	29.0	270
	220	60	165	0.040	5.0	2400	25.4	0.72	.13	31.3	34.0	270
3115PS-23T-B20-A00	230	50	150	0.050	7.0	2200	22.0	0.63	.10	24.5	30.0	270
	230	60	150	0.045	6.0	2500	26.0	0.74	.14	35.2	34.0	270
** 3115PS-24T-B20-A00	240	50	150	0.055	7.0	2200	22.0	0.63	.10	24.5	30.0	270
	240	60	150	0.045	6.0	2600	26.5	0.75	.15	37.2	35.0	270
** 3115PS-10T-B10-B00	100	50	65	0.065	4.5	1700	17.6	0.50	.06	16.6	23.0	270
	100	60	65	0.055	4.0	1900	19.4	0.55	.08	21.5	25.0	270
3115PS-12T-B10-A00	115	50	75	0.060	4.5	1700	17.6	0.50	.06	16.6	23.0	270
	115	60	75	0.055	4.0	1900	19.4	0.55	.08	21.5	25.0	270
** 3115PS-20T-B10-B00	200	50	130	0.045	4.5	1700	17.6	0.50	.06	16.6	23.0	270
	200	60	160	0.040	4.0	1900	19.4	0.55	.08	21.5	26.0	270
** 3115PS-22T-B10-B00	220	50	150	0.050	5.5	1750	17.6	0.50	.06	16.6	23.0	270
	220	60	150	0.045	4.5	2000	21.2	0.60	.09	23.5	26.0	270
3115PS-23T-B10-A00	230	50	150	0.055	6.0	1800	17.6	0.50	.07	17.6	23.0	270
	230	60	150	0.050	5.0	2100	22.0	0.63	.10	24.5	26.0	270
** 3115PS-24T-B10-A00	240	50	150	0.060	7.0	1800	17.6	0.50	.07	17.6	23.0	270
	240	60	150	0.055	6.0	2150	21.6	0.64	.10	25.4	26.0	270

Rotation: Counterclockwise

Airflow Outlet: Air Out Over Struts

\*1: Maximum Values in Free Air

\*\* Contact NMB for Availability

\*2: Average Values in Free Air

\*3: Minimum Values in Free Air

**General Specifications**

Motor Structure: Shaded Pole Induction Motor  
 Motor Protection: Impedance Protection  
 Insulation Resistance:  
 10M Ω or over with a DC500V Megger  
 Dielectric Withstand Voltage: AC 700V 1s  
 Allowable Ambient Temperature Range:  
 -10°C ~ +70°C (Operating)  
 -40°C ~ +70°C (Storage)  
 (non-condensing environment)

**Expected Life**

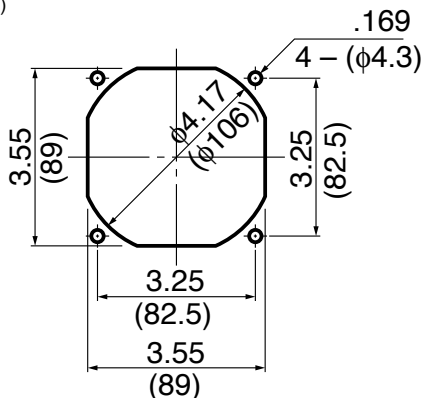
Failure Rate: 10%  
 25°C 50,000 Hours

**Material**

Casing : Aluminum  
 Impeller : Polycarbonate  
 (Glass Fiber-Containing)  
 Bearing : Ball Bearing  
 Lead Wire : AWG22, UL3266, CSA CL1252  
 or Terminal : Faston #110 or equivalent

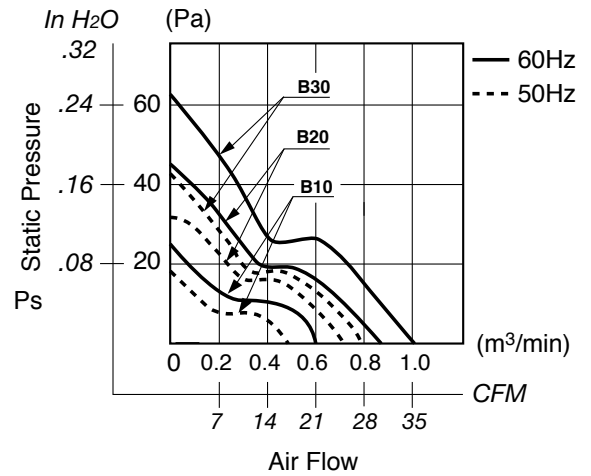
**Panel Cut-Outs**

Units:  $\frac{\text{inch}}{\text{mm}}$

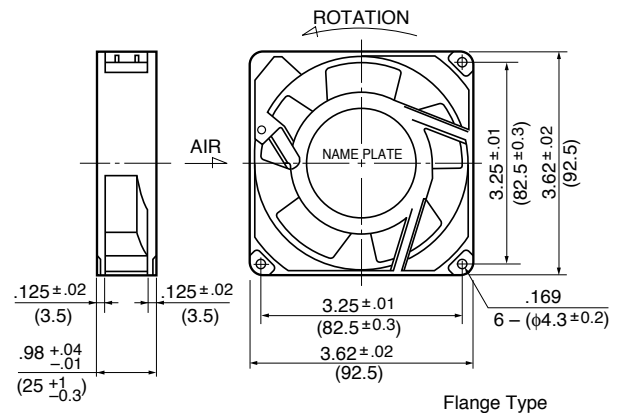


INLET SIDE / OUTLET SIDE

**Characteristic Curves**



**Outline**



Flange Type

## Specifications

MODEL	Rated Voltage	Frequency	Starting Voltage	Current	Input Power	Speed	Max. Air Flow		Max. Static Pressure		Noise	Mass
	(V)	(Hz)	(V)	(A) <sup>*1</sup>	(W) <sup>+10% -20%</sup>	(min <sup>-1</sup> ) <sup>*3</sup>	CFM	(m <sup>3</sup> /min) <sup>*3</sup>	in H <sub>2</sub> O	(Pa) <sup>*3</sup>	(dB) <sup>*2</sup>	(g)
** 3610PS-10T-B30-B00	100	50	65	0.190	13.0	2600	28.0	0.80	.17	43.1	33.5	300
	100	60	65	0.150	10.0	3100	34.5	0.98	.24	60.7	38.0	300
3610PS-12T-B30-A00	115	50	75	0.170	12.0	2600	28.0	0.80	.17	43.1	33.5	300
	115	60	75	0.130	9.0	3100	34.5	0.98	.24	60.7	38.0	300
** 3610PS-20T-B30-B00	200	50	130	0.100	13.0	2600	28.0	0.80	.17	43.1	33.5	300
	200	60	130	0.080	10.0	3100	34.5	0.98	.24	60.7	38.0	300
** 3610PS-22T-B30-B00	220	50	165	0.100	13.0	2600	28.0	0.80	.17	43.1	34.0	300
	220	60	165	0.080	10.0	3100	34.5	0.98	.24	60.7	39.0	300
3610PS-23T-B30-A00	230	50	180	0.090	13.0	2600	28.0	0.80	.17	43.1	34.0	300
	230	60	180	0.070	10.0	3100	34.5	0.98	.24	60.7	39.0	300
** 3610PS-24T-B30-A00	240	50	180	0.085	13.0	2600	28.0	0.80	.17	43.1	34.0	300
	240	60	180	0.065	10.0	3100	34.5	0.98	.24	60.7	39.0	300
** 3610PS-10T-B20-B00	100	50	65	0.095	7.0	2100	21.0	0.60	.11	27.4	30.0	300
	100	60	65	0.085	6.0	2500	28.0	0.80	.16	39.2	35.0	300
3610PS-12T-B20-A00	115	50	75	0.095	7.0	2100	21.0	0.60	.12	29.4	30.0	300
	115	60	75	0.090	6.0	2500	28.0	0.80	.16	39.2	35.0	300
** 3610PS-20T-B20-B00	200	50	130	0.060	7.0	2100	22.9	0.65	.11	27.4	30.0	300
	200	60	160	0.050	6.0	2500	28.0	0.80	.16	39.0	35.0	300
** 3610PS-22T-B20-B00	220	50	165	0.050	6.5	2100	21.0	0.60	.12	29.4	30.0	300
	220	60	165	0.050	5.5	2500	28.0	0.80	.15	38.2	35.0	300
3610PS-23T-B20-A00	230	50	180	0.050	7.0	2100	21.0	0.60	.12	29.4	30.0	300
	230	60	180	0.050	6.0	2500	28.0	0.80	.16	39.2	35.0	300
** 3610PS-24T-B20-A00	240	50	180	0.050	9.0	2100	21.0	0.60	.12	29.4	30.0	300
	240	60	180	0.050	8.0	2500	28.0	0.80	.16	39.2	35.0	300
** 3610PS-10T-B10-B00	100	50	65	0.100	7.0	1450	16.0	0.46	.05	13.7	23.0	300
	100	60	65	0.090	6.0	1800	20.0	0.58	.08	19.6	26.0	300
3610PS-12T-B10-A00	115	50	75	0.090	7.0	1450	16.0	0.46	.05	13.7	22.0	300
	115	60	75	0.080	6.0	1800	20.0	0.58	.08	19.6	25.0	300
** 3610PS-20T-B10-B00	200	50	130	0.045	7.0	1500	16.0	0.46	.05	13.7	24.0	300
	200	60	130	0.040	6.0	1900	21.0	0.60	.08	19.6	27.0	300
** 3610PS-22T-B10-B00	220	50	165	0.050	8.0	1450	16.0	0.46	.05	13.7	23.0	300
	220	60	165	0.040	7.0	1800	21.0	0.60	.08	19.6	26.0	300
3610PS-23T-B10-A00	230	50	180	0.050	7.0	1450	16.0	0.46	.05	13.7	22.0	300
	230	60	180	0.040	6.0	1800	20.0	0.58	.08	19.6	26.0	300
** 3610PS-24T-B10-A00	240	50	180	0.050	8.0	1450	16.0	0.46	.05	13.7	24.0	300
	240	60	180	0.045	7.0	1800	21.0	0.60	.08	19.6	27.0	300

Rotation: Counterclockwise  
 \*\* Contact NMB for Availability

Airflow Outlet: Air Out Over Struts

\*1: Maximum Values in Free Air  
 \*2: Average Values in Free Air  
 \*3: Minimum Values in Free Air

**General Specifications**

Motor Structure: Shaded Pole Induction Motor  
 Motor Protection: Impedance Protection  
 Insulation Resistance:  
 10M Ω or over with a DC500V Megger  
 Dielectric Withstand Voltage: AC 700V 1s  
 Allowable Ambient Temperature Range:  
 -10°C ~ +70°C (Operating)  
 -40°C ~ +70°C (Storage)

**Expected Life**

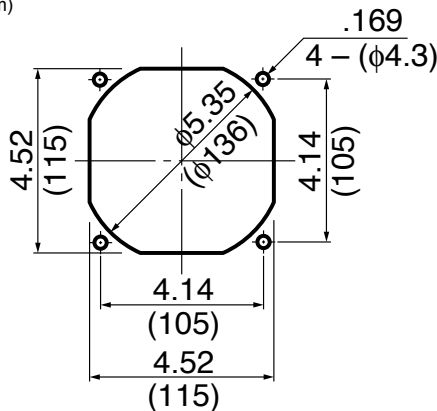
Failure Rate: 10%  
 25°C 50,000 Hours

**Material**

Casing : Aluminum  
 Impeller : Polycarbonate (Glass Fiber-Containing)  
 Bearing : Ball Bearing  
 Terminal : Faston #110 or equivalent

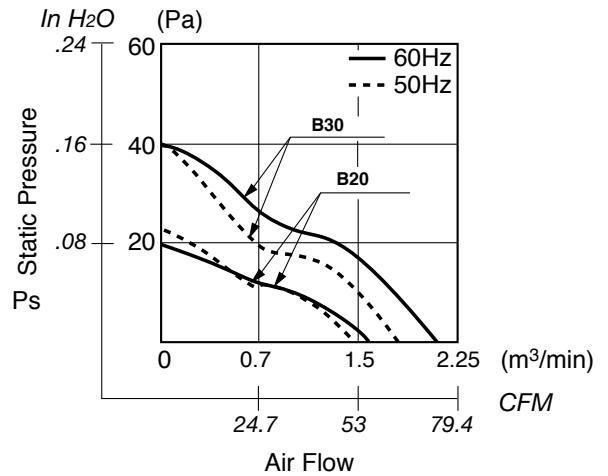
**Panel Cut-Outs**

Units:  $\frac{\text{inch}}{\text{mm}}$

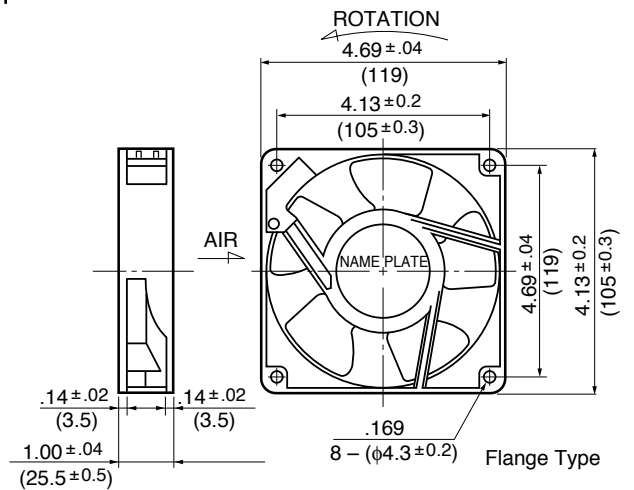


INLET SIDE / OUTLET SIDE

**Characteristic Curves**



**Outline**



## Specifications

MODEL	Rated Voltage	Frequency	Starting Voltage	Current	Input Power	Speed	Max. Air Flow		Max. Static Pressure		Noise	Mass
	(V)	(Hz)	(V)	(A) <sup>1</sup>	(W) <sup>+10% -20%</sup>	(min <sup>-1</sup> ) <sup>3</sup>	CFM	(m <sup>3</sup> /min) <sup>3</sup>	in H <sub>2</sub> O	(Pa) <sup>3</sup>	(dB) <sup>2</sup>	(g)
** 4710PS-10T-B30-B00	100	50	65	0.220	14.0	2300	63.5	1.80	.16	41.1	34.0	360
	100	60	65	0.180	11.0	2700	70.6	2.00	.16	41.1	38.0	360
4710PS-12T-B30-A00	115	50	75	0.190	14.0	2300	63.5	1.80	.16	41.1	34.0	360
	115	60	75	0.160	11.0	2700	70.6	2.00	.16	41.1	38.0	360
** 4710PS-20T-B30-B00	200	50	130	0.110	14.0	2300	63.5	1.80	.16	41.1	34.0	360
	200	60	130	0.090	11.0	2700	70.6	2.00	.16	41.1	38.0	360
** 4710PS-22T-B30-B00	220	50	175	0.100	14.0	2300	63.5	1.80	.16	41.1	34.0	360
	220	60	175	0.080	11.0	2700	70.6	2.00	.16	41.1	38.0	360
4710PS-23T-B30-A00	230	50	175	0.100	14.0	2300	63.5	1.80	.16	41.1	34.0	360
	230	60	175	0.090	11.0	2700	70.6	2.00	.16	41.1	38.0	360
** 4710PS-24T-B30-A00	240	50	130	0.100	15.0	2300	60.0	1.70	.16	41.1	34.0	360
	240	60	130	0.080	13.0	2700	70.6	2.00	.16	41.1	38.0	360
** 4710PS-10T-B20-B00	100	50	65	0.120	8.0	1900	49.4	1.40	.08	19.6	29.0	360
	100	60	65	0.100	7.0	2100	53.0	1.50	.086	21.5	30.0	360
4710PS-12T-B20-A00	115	50	75	0.100	8.0	1900	49.4	1.40	.09	23.5	29.0	360
	115	60	75	0.090	7.0	2000	53.0	1.50	.08	21.5	30.0	360
** 4710PS-20T-B20-B00	200	50	130	0.070	9.0	1900	45.9	1.30	.08	19.6	29.0	360
	200	60	160	0.060	8.0	2000	53.0	1.50	.086	21.5	30.0	360
** 4710PS-22T-B20-B00	220	50	175	0.060	9.0	1900	49.4	1.40	.08	19.6	29.0	360
	220	60	175	0.050	8.0	2100	53.0	1.50	.086	21.5	30.0	360
** 4710PS-23T-B20-A00	230	50	175	0.060	9.0	1900	49.4	1.40	.09	23.5	29.0	360
	230	60	175	0.050	8.0	2100	53.0	1.50	.08	21.5	30.0	360
4710PS-24T-B20-A00	240	50	140	0.060	9.0	1900	49.4	1.40	.08	19.6	29.0	360
	240	60	140	0.050	8.0	2100	53.0	1.50	.086	21.5	30.0	360

Rotation: Counterclockwise  
 \*\* Contact NMB for Availability

Airflow Outlet: Air Out Over Struts

\*1: Maximum Values in Free Air  
 \*2: Average Values in Free Air  
 \*3: Minimum Values in Free Air

## General Specifications

- Motor Structure: Shaded Pole Induction Motor
- Motor Protection: Impedance Protection
- Insulation Resistance: 10M Ω or over with a DC500V Megger
- Dielectric Withstand Voltage: AC 700V 1s
- Allowable Ambient Temperature Range:
  - 10°C ~ +70°C (Operating)
  - 40°C ~ +70°C (Storage)
  - (non-condensing environment)

## Expected Life

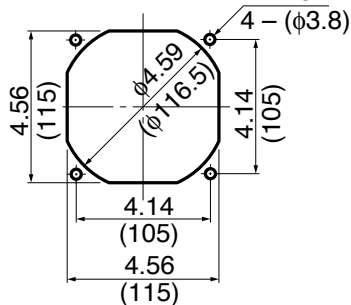
Failure Rate: 10%  
25°C 100,000 Hours (D00)

## Material

- Casing : Aluminum Alloy
- Impeller : UL94V-O Reinforced Plastic
- Bearing : Ball Bearing
- Lead Wire : AWG22, UL3266, CSA CL1252
- or Terminal : Faston #110 or equivalent

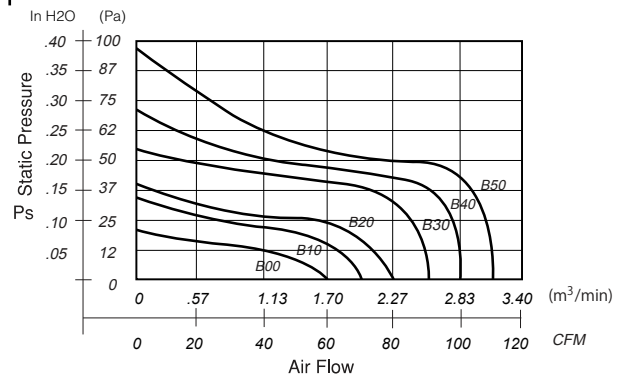
## Panel Cut-Outs

Units:  $\frac{\text{inch}}{\text{mm}}$

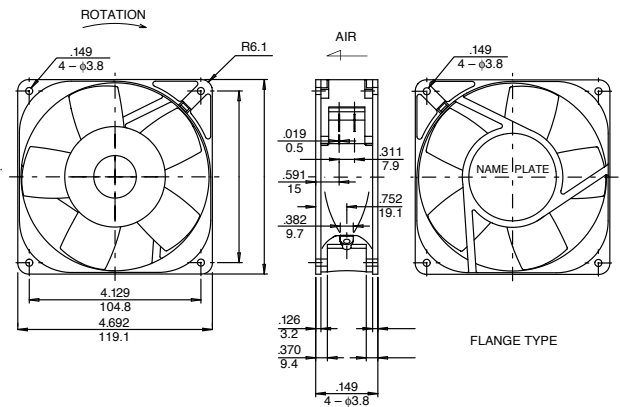


INLET SIDE / OUTLET SIDE

## Characteristic Curves



## Outline



## Specifications

MODEL	Rated Voltage	Frequency	Starting Voltage	Current	Input Power	Speed	Max. Air Flow		Max. Static Pressure		Noise	Mass
	(V)	(Hz)	(V)	(A) <sup>*1</sup>	(W) <sup>*1</sup>	(min <sup>-1</sup> ) <sup>*1</sup>	CFM	(m <sup>3</sup> /min) <sup>*1</sup>	in H <sub>2</sub> O	(Pa) <sup>*1</sup>	(dB) <sup>*1</sup>	(g)
4715FS-12T-B00-D00	115	60	75	0.090	7.5	1700	60.0	1.70	.08	20.0	31	550
4715FS-12T-B10-D00	115	60	75	0.110	10.0	1900	70.0	1.98	.12	30.0	33	550
4715FS-12T-B20-D00	115	60	75	0.100	9.8	2300	80.0	2.25	.13	32.5	36	550
4715FS-12T-B30-D00	115	60	75	0.180	14.5	2650	90.0	2.50	.22	55.0	39	550
4715FS-12T-B40-D00	115	60	75	0.170	14.0	2800	100.0	2.80	.29	72.5	42	550
4715FS-12T-B50-D00	115	60	75	0.190	14.4	3100	110.0	3.10	.37	92.5	45	550
4715FS-23T-B00-D00	230	60	175	0.030	5.5	1600	55.0	1.50	.07	17.5	31	550
4715FS-23T-B10-D00	230	60	175	0.050	9.0	1900	70.0	1.98	.12	30.0	33	550
4715FS-23T-B20-D00	230	60	175	0.050	8.8	2300	80.0	2.25	.13	32.5	36	550
4715FS-23T-B30-D00	230	60	175	0.090	12.0	2650	90.0	2.50	.22	55.0	39	550
4715FS-23T-B40-D00	230	60	175	0.090	14.0	2800	100.0	2.80	.28	70.0	42	550
4715FS-23T-B50-D00	230	60	175	0.080	14.0	3100	110.0	3.10	.37	92.5	45	550

Rotation: Counterclockwise

Airflow Outlet: Air In Over Struts

\*1: Maximum Values in Free Air

\*2: Average Values in Free Air

\*3: Minimum Values in Free Air



### General Specifications

**Motor Structure:** Shaded Pole Induction Motor  
**Motor Protection:** Impedance Protection  
**Insulation Resistance:**  
 10M Ω or over with a DC500V Megger  
**Dielectric Withstand Voltage:** AC 700V 1s  
**Allowable Ambient Temperature Range:**  
 -10°C ~ +65°C (Operating)  
 -40°C ~ +70°C (Storage)  
 (non-condensing environment)

### Expected Life

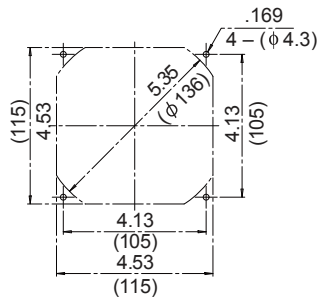
**Failure Rate: 10%**  
 25°C 100,000 Hours

### Material

**Casing :** Aluminum  
**Impeller :** Polybutylene terephthalate  
 (Glass Fiber-Containing)  
**Bearing :** Ball Bearings  
**Lead Wire :** Faston #110 or Equivalent

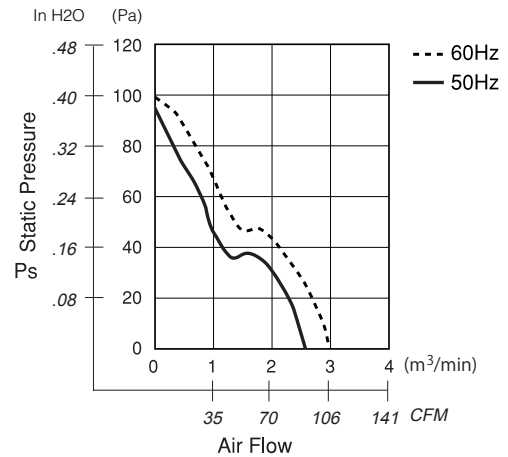
### Panel Cut-Outs

Units: inch (mm)

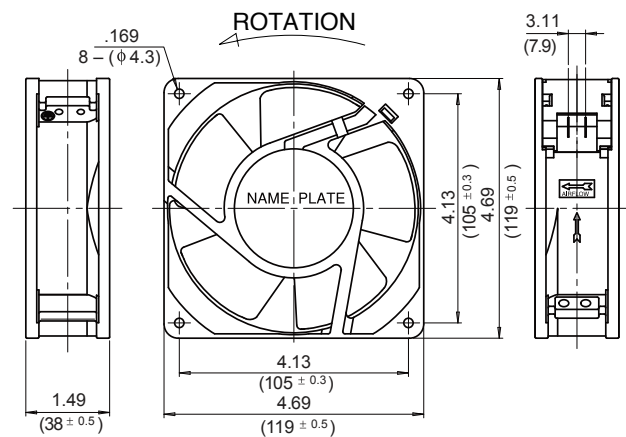


INLET SIDE / OUTLET SIDE

### Characteristic Curves



### Outline



### Specifications

MODEL	Rated Voltage	Frequency	Starting Voltage	Current	Input Power	Speed	Max. Air Flow		Max. Static Pressure		Noise	Mass
	(V)	(Hz)	(V)	(A) <sup>1</sup>	(W)	(min <sup>-1</sup> ) <sup>3</sup>	CFM	(m <sup>3</sup> /min) <sup>2</sup>	in H <sub>2</sub> O	(Pa) <sup>2</sup>	(dB) <sup>2</sup>	(g)
** 4715HS-10T-B5A-B00	100	50	65	0.370	18.0	2600	91.8	2.60	0.380	94.0	40	570
** 4715HS-10T-B5A-B00	100	60	65	0.290	15.5	3100	105.9	3.00	0.400	100.0	44	570
** 4715HS-12T-B5A-A00	115	50	75	0.320	18.0	2600	91.8	2.60	0.380	94.0	40	570
** 4715HS-12T-B5A-A00	115	60	75	0.250	15.5	3100	105.9	3.00	0.400	100.0	44	570
** 4715HS-20T-B5A-B00	200	50	130	0.180	18.0	2600	91.8	2.60	0.380	94.0	40	570
** 4715HS-20T-B5A-B00	200	60	130	0.150	15.5	3100	105.9	3.00	0.400	100.0	44	570
** 4715HS-22T-B5A-B00	220	50	145	0.160	18.0	2600	91.8	2.60	0.380	94.0	40	570
** 4715HS-22T-B5A-B00	220	60	145	0.130	15.5	3100	105.9	3.00	0.400	100.0	44	570
** 4715HS-23T-B5A-A00	230	50	175	0.160	18.0	2600	91.8	2.60	0.380	94.0	40	570
** 4715HS-23T-B5A-A00	230	60	175	0.120	15.5	3100	105.9	3.00	0.400	100.0	44	570
** 4715HS-24T-B5A-A00	240	50	175	0.150	18.0	2600	91.8	2.60	0.380	94.0	40	570
** 4715HS-24T-B5A-A00	240	60	175	0.120	15.5	3100	105.9	3.00	0.400	100.0	44	570

Rotation: Counterclockwise  
 \*\* Contact NMB for Availability

Airflow Outlet: Air Out Over Struts

<sup>1</sup>: Maximum Values in Free Air  
<sup>2</sup>: Average Values in Free Air  
<sup>3</sup>: Minimum Values in Free Air

## General Specifications

**Motor Structure:** Shaded Pole Induction Motor  
**Motor Protection:** Impedance Protection  
**Insulation Resistance:**  
 10M  $\Omega$  or over with a DC500V Megger  
**Dielectric Withstand Voltage:** AC 700V 1s  
**Allowable Ambient Temperature Range:**  
 -10°C ~ +65°C (Operating)  
 -40°C ~ +70°C (Storage)  
 (non-condensing environment)

## Expected Life

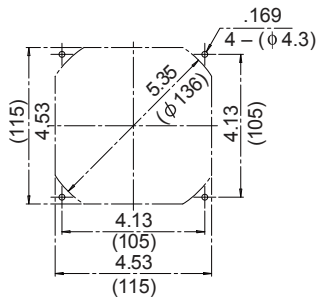
**Failure Rate: 10%**  
 25°C 100,000 Hours

## Material

**Casing :** Aluminum  
**Impeller :** Polybutylene terephthalate  
 (Glass Fiber-Containing)  
**Bearing :** Ball Bearings  
**Lead Wire :** Faston #110 or Equivalent

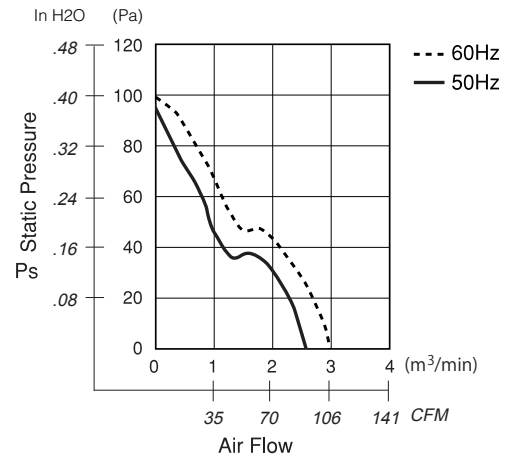
## Panel Cut-Outs

Units:  $\frac{\text{inch}}{\text{mm}}$

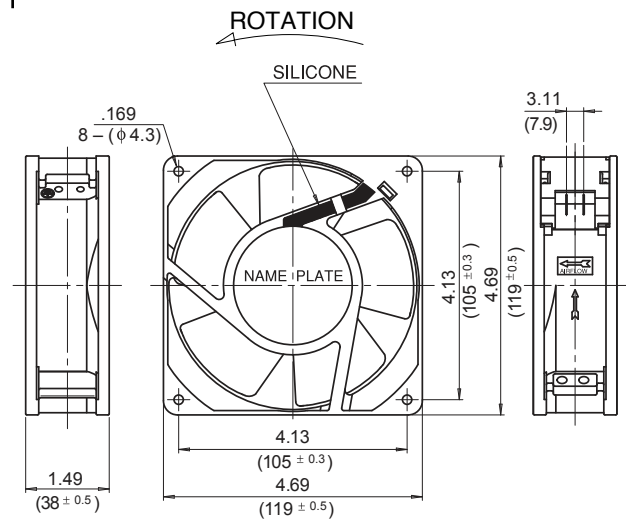


INLET SIDE / OUTLET SIDE

## Characteristic Curves



## Outline



## Specifications

MODEL	Rated Voltage	Frequency	Starting Voltage	Current	Input Power	Speed	Max. Air Flow		Max. Static Pressure		Noise	Mass
	(V)	(Hz)	(V)	(A) <sup>*1</sup>	(W)	(min <sup>-1</sup> ) <sup>*3</sup>	CFM	(m <sup>3</sup> /min) <sup>*2</sup>	in H <sub>2</sub> O	(Pa) <sup>*2</sup>	(dB) <sup>*2</sup>	(g)
** 4715HS-10T-B50-BM0	100	50	65	0.370	18.0	2600	91.8	2.60	0.380	94.0	40	610
** 4715HS-10T-B50-BM0	100	60	65	0.290	15.5	3100	105.9	3.00	0.400	100.0	44	610
** 4715HS-12T-B50-AM0	115	50	75	0.320	18.0	2600	91.8	2.60	0.380	94.0	40	610
** 4715HS-12T-B50-AM0	115	60	75	0.250	15.5	3100	105.9	3.00	0.400	100.0	44	610
** 4715HS-20T-B50-BM0	200	50	130	0.180	18.0	2600	91.8	2.60	0.380	94.0	40	610
** 4715HS-20T-B50-BM0	200	60	130	0.150	15.5	3100	105.9	3.00	0.400	100.0	44	610
** 4715HS-22T-B50-BM0	220	50	145	0.160	18.0	2600	91.8	2.60	0.380	94.0	40	610
** 4715HS-22T-B50-BM0	220	60	145	0.130	15.5	3100	105.9	3.00	0.400	100.0	44	610
** 4715HS-23T-B50-AM0	230	50	175	0.160	18.0	2600	91.8	2.60	0.380	94.0	40	610
** 4715HS-23T-B50-AM0	230	60	175	0.120	15.5	3100	105.9	3.00	0.400	100.0	44	610
** 4715HS-24T-B50-AM0	240	50	175	0.150	18.0	2600	91.8	2.60	0.380	94.0	40	610
** 4715HS-24T-B50-AM0	240	60	175	0.120	15.5	3100	105.9	3.00	0.400	100.0	44	610

Rotation: Counterclockwise

Airflow Outlet: Air Out Over Struts

\*1: Maximum Values in Free Air

\*2: Average Values in Free Air

\*3: Minimum Values in Free Air

\*\* Contact NMB for Availability

## General Specifications

**Motor Structure:** Shaded Pole Induction Motor  
**Motor Protection:** Impedance Protection  
**Insulation Resistance:**  
 10M Ω or over with a DC500V Megger  
**Dielectric Withstand Voltage:** AC 700V 1s  
**Allowable Ambient Temperature Range:**  
 -10°C ~ +70°C (Operating)  
 -40°C ~ +70°C (Storage)  
 (non-condensing environment)

## Expected Life

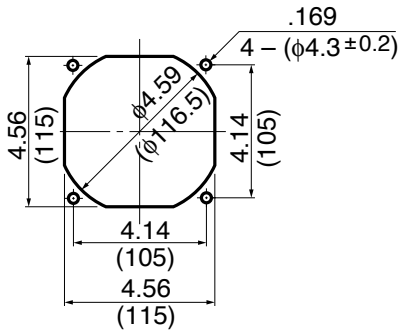
**Failure Rate: 10%**  
 25°C 50,000 Hours

## Material

**Casing** : Aluminum  
**Impeller** : Polycarbonate (Glass Fiber-Containing)  
**Bearing** : Ball Bearing  
**Lead Wire** : AWG22, UL3266, CSA CLR52  
**or Terminal** : Faston #110 or equivalent

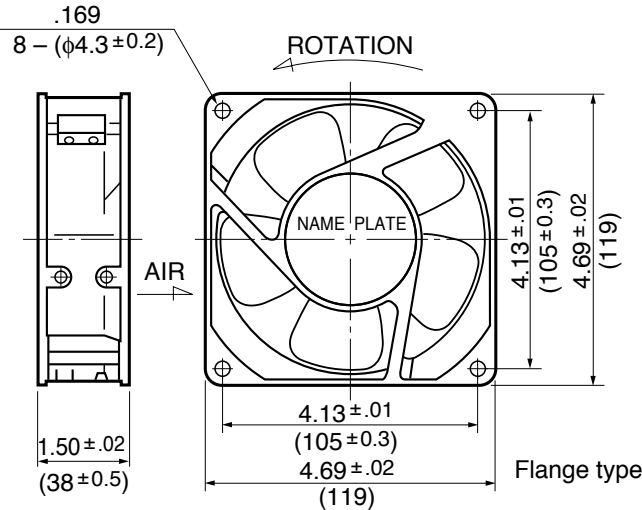
## Panel Cut-Outs

Units:  $\frac{\text{inch}}{\text{mm}}$

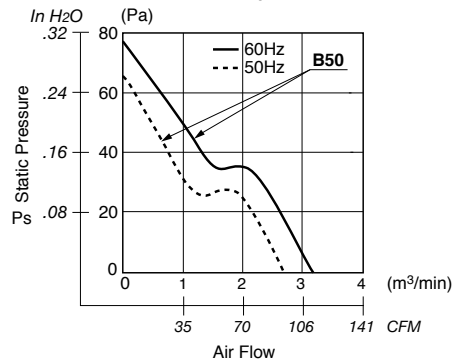
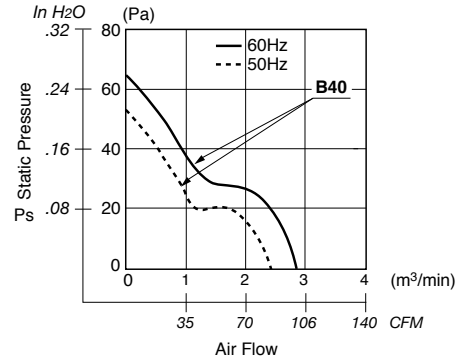
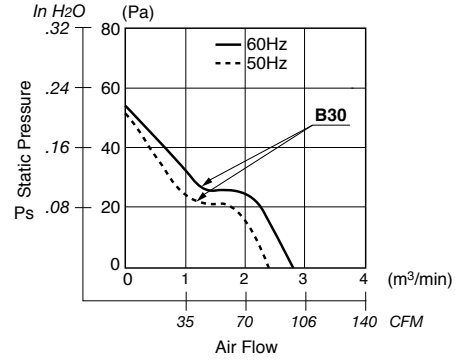
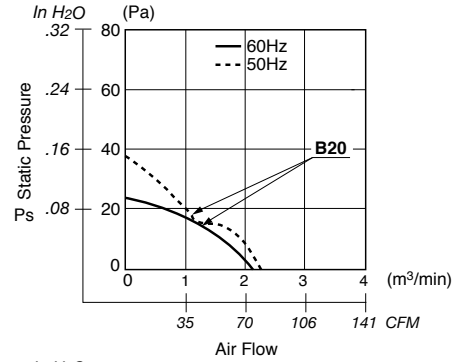
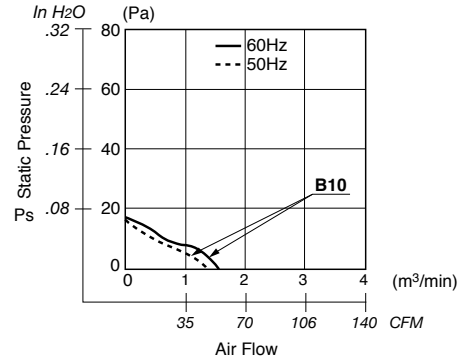


INLET SIDE / OUTLET SIDE

## Outline



## Characteristic Curves



## Specifications

MODEL	Rated Voltage	Frequency	Starting Voltage	Current	Input Power	Speed	Max. Air Flow		Max. Static Pressure		Noise	Mass
	(V)	(Hz)	(V)	(A) <sup>*1</sup>	(W) <sup>+10% -20%</sup>	(min <sup>-1</sup> ) <sup>*3</sup>	CFM	(m <sup>3</sup> /min) <sup>*3</sup>	in H <sub>2</sub> O	(Pa) <sup>*3</sup>	(dB) <sup>*2</sup>	(g)
4715MS-12T-B50-A00	115	50	65	0.250	15.5	2600	88.2	2.50	.259	64.6	37.0	550
	115	60	65	0.210	14.5	2900	102.0	2.90	.309	76.4	41.0	550
4715MS-23T-B50-A00	230	50	175	0.120	15.0	2600	88.2	2.50	.255	63.7	37.0	550
	230	60	175	0.100	14.0	2900	102.0	2.90	.283	70.5	41.0	550
4715MS-12T-B40-A00	115	50	75	0.220	15.0	2450	85.0	2.40	.204	50.9	35.0	550
	115	60	75	0.190	13.0	2750	95.0	2.70	.259	64.6	39.0	550
4715MS-23T-B40-A00	230	50	175	0.120	15.0	2450	85.0	2.40	.216	53.9	35.0	550
	230	60	175	0.100	13.0	2750	95.0	2.70	.255	63.7	39.0	550
4715MS-12T-B30-A00	115	50	75	0.160	11.0	2400	81.0	2.30	.200	49.9	34.0	550
	115	60	75	0.140	10.0	2600	88.2	2.50	.200	49.9	37.0	550
4715MS-23T-B30-A00	230	50	175	0.100	12.0	2400	81.0	2.30	.197	49.0	34.0	550
	230	60	175	0.080	11.0	2600	88.2	2.50	.208	51.9	37.0	550
4715MS-12T-B20-A00	115	50	75	0.100	7.0	2100	76.6	2.00	.141	35.2	32.0	550
	115	60	75	0.100	7.0	1950	67.0	1.90	.098	24.5	30.0	550
4715MS-23T-B20-A00	230	50	175	0.060	7.5	2100	70.6	2.00	.141	35.2	32.0	550
	230	60	175	0.060	7.5	1900	67.0	1.90	.086	21.5	30.0	550
4715MS-12T-B10-A00	115	50	75	0.090	6.0	1350	45.9	1.30	.062	15.6	27.0	550
	115	60	75	0.080	5.5	1450	49.4	1.40	.066	16.6	28.0	550
4715MS-23T-B10-A00	230	50	175	0.050	6.5	1350	45.9	1.30	.059	14.7	27.0	550
	230	60	175	0.045	6.0	1450	49.4	1.40	.059	14.7	28.0	550

Rotation: Counterclockwise

Airflow Outlet: Air Out Over Struts

\*1: Maximum Values in Free Air

\*2: Average Values in Free Air

\*3: Minimum Values in Free Air

## General Specifications

**Motor Structure:** Shaded Pole Induction Motor  
**Motor Protection:** B5A Class : Thermal Protection  
**Insulation Resistance:**  
 10M Ω or over with a DC500V Megger  
**Dielectric Withstand Voltage:** AC 700V 1s  
**Allowable Ambient Temperature Range:**  
 -10°C ~ +65°C (Operating)  
 -40°C ~ +70°C (Storage)  
 (non-condensing environment)

## Expected Life

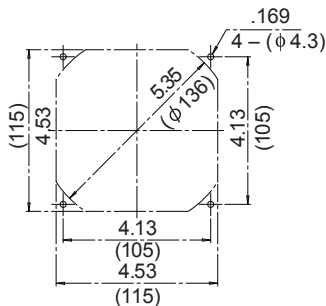
**Failure Rate: 10%**  
 25°C 50,000 Hours

## Material

**Casing :** Aluminum  
**Impeller :** Steel  
**Bearing :** Ball Bearings  
**Lead Wire :** Faston #110 or Equivalent

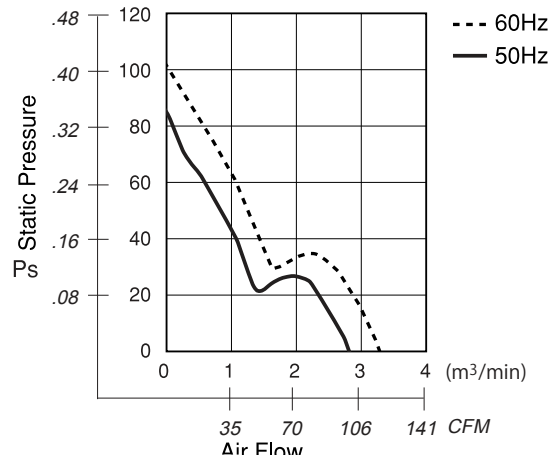
## Panel Cut-Outs

Units: inch (mm)

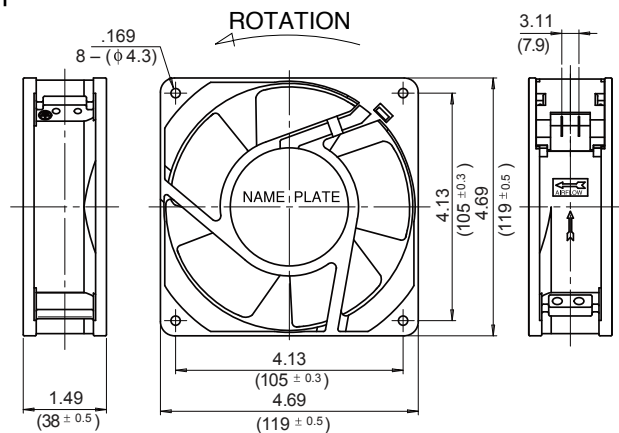


INLET SIDE / OUTLET SIDE

## Characteristic Curves



## Outline



## Specifications

MODEL	Rated Voltage	Frequency	Starting Voltage	Current	Input Power	Speed	Max. Air Flow		Max. Static Pressure		Noise	Mass
	(V)	(Hz)	(V)	(A) <sup>1</sup>	(W)	(min <sup>-1</sup> ) <sup>3</sup>	CFM	(m³/min) <sup>2</sup>	in H <sub>2</sub> O	(Pa) <sup>2</sup>	(dB) <sup>2</sup>	(g)
** 4715TS-10T-B5A-B00	100	50	65	0.450	20.0	2600	98.84	2.80	0.352	88.0	46	610
** 4715TS-10T-B5A-B00	100	60	65	0.340	17.0	3100	116.49	3.30	0.400	100.0	50	610
4715TS-12T-B5A-A00	115	50	75	0.390	21.0	2600	98.84	2.80	0.352	88.0	46	610
4715TS-12T-B5A-A00	115	60	75	0.300	17.0	3100	116.49	3.30	0.400	100.0	50	610
** 4715TS-20T-B5A-B00	200	50	130	0.220	21.0	2600	98.84	2.80	0.352	88.0	46	610
** 4715TS-20T-B5A-B00	200	60	130	0.170	17.0	3100	116.49	3.30	0.400	100.0	50	610
** 4715TS-22T-B5A-B00	220	50	145	0.200	20.0	2600	98.84	2.80	0.352	88.0	46	610
** 4715TS-22T-B5A-B00	220	60	145	0.150	17.0	3100	116.49	3.30	0.400	100.0	50	610
4715TS-23T-B5A-A00	230	50	175	0.190	21.0	2600	98.84	2.80	0.352	88.0	46	610
4715TS-23T-B5A-A00	230	60	175	0.140	17.0	3100	116.49	3.30	0.400	100.0	50	610
** 4715TS-24T-B5A-A00	240	50	175	0.180	20.0	2600	98.84	2.80	0.352	88.0	46	610
** 4715TS-24T-B5A-A00	240	60	175	0.140	17.0	3100	116.49	3.30	0.400	100.0	50	610

Rotation: Counterclockwise  
 \*\* Contact NMB for Availability

Airflow Outlet: Air Out Over Struts

<sup>1</sup>: Maximum Values in Free Air  
<sup>2</sup>: Average Values in Free Air  
<sup>3</sup>: Minimum Values in Free Air

## General Specifications

**Motor Structure:** Shaded Pole Induction Motor  
**Motor Protection:** Impedance Protection  
**Insulation Resistance:**  
 10M  $\Omega$  or over with a DC500V Megger  
**Dielectric Withstand Voltage:** AC 700V 1s  
**Allowable Ambient Temperature Range:**  
 -10°C ~ +60°C (Operating)  
 -40°C ~ +70°C (Storage)  
 (non-condensing environment)

## Expected Life

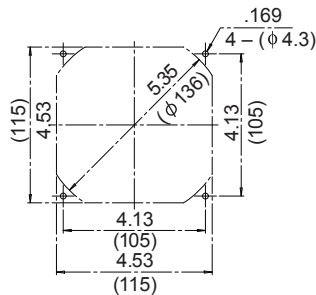
**Failure Rate: 10%**  
 25°C 50,000 Hours

## Material

**Casing :** Aluminum  
**Impeller :** Steel  
**Bearing :** Ball Bearings  
**Lead Wire :** Faston #110 or Equivalent

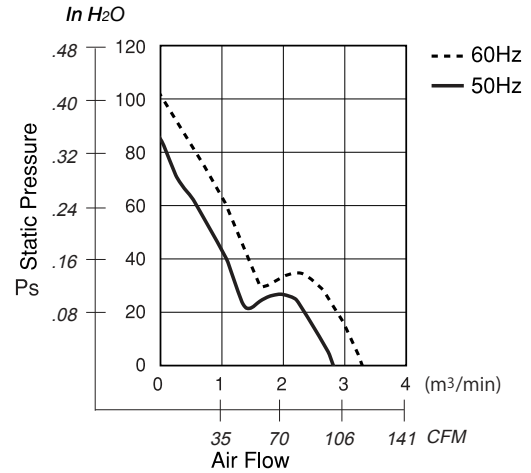
## Panel Cut-Outs

Units: inch (mm)

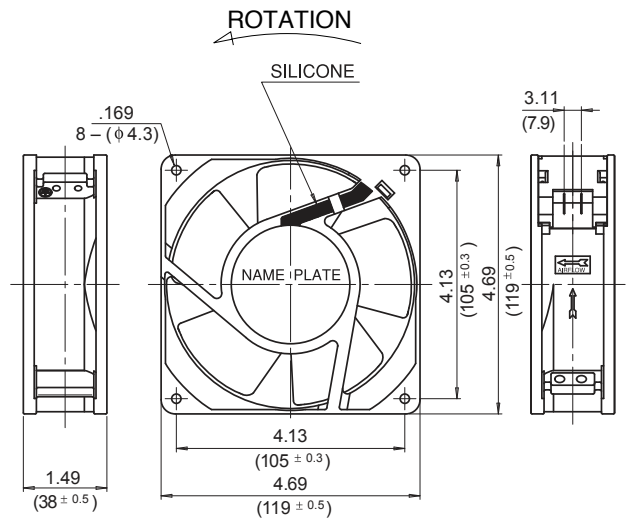


INLET SIDE / OUTLET SIDE

## Characteristic Curves



## Outline



## Specifications

MODEL	Rated Voltage	Frequency	Starting Voltage	Current	Input Power	Speed	Max. Air Flow		Max. Static Pressure		Noise	Mass
	(V)	(Hz)	(V)	(A) <sup>1</sup>	(W)	(min <sup>-1</sup> ) <sup>3</sup>	CFM	(m³/min) <sup>2</sup>	in H <sub>2</sub> O	(Pa) <sup>2</sup>	(dB) <sup>2</sup>	(g)
** 4715TS-10T-B50-BM0	100	50	65	0.450	20.0	2600	98.84	2.80	0.352	88.0	46	650
** 4715TS-10T-B50-BM0	100	60	65	0.340	17.0	3100	116.49	3.30	0.400	100.0	50	650
4715TS-12T-B50-AM0	115	50	75	0.390	21.0	2600	98.84	2.80	0.352	88.0	46	650
4715TS-12T-B50-AM0	115	60	75	0.300	17.0	3100	116.49	3.30	0.400	100.0	50	650
** 4715TS-20T-B50-BM0	200	50	130	0.220	21.0	2600	98.84	2.80	0.352	88.0	46	650
** 4715TS-20T-B50-BM0	200	60	130	0.170	17.0	3100	116.49	3.30	0.400	100.0	50	650
** 4715TS-22T-B50-BM0	220	50	145	0.200	20.0	2600	98.84	2.80	0.352	88.0	46	650
** 4715TS-22T-B50-BM0	220	60	145	0.150	17.0	3100	116.49	3.30	0.400	100.0	50	650
4715TS-23T-B50-AM0	230	50	175	0.190	21.0	2600	98.84	2.80	0.352	88.0	46	650
4715TS-23T-B50-AM0	230	60	175	0.140	17.0	3100	116.49	3.30	0.400	100.0	50	650
** 4715TS-24T-B50-AM0	240	50	175	0.180	20.0	2600	98.84	2.80	0.352	88.0	46	650
** 4715TS-24T-B50-AM0	240	60	175	0.140	17.0	3100	116.49	3.30	0.400	100.0	50	650

Rotation: Counterclockwise

Airflow Outlet: Air Out Over Struts

\*1: Maximum Values in Free Air

\*\* Contact NMB for Availability

\*2: Average Values in Free Air

\*3: Minimum Values in Free Air

## General Specifications

- Motor Structure: Capacitor-Run Induction Motor
- Motor Protection: B10~B20 Impedance Protection  
B30 Thermal Protection
- Insulation Resistance:  
10M  $\Omega$  or over with a DC500V Megger
- Dielectric Withstand Voltage: AC 700V 1s
- Allowable Ambient Temperature Range:  
-10°C ~ +70°C (Operating)  
-40°C ~ +70°C (Storage)  
(non-condensing environment)

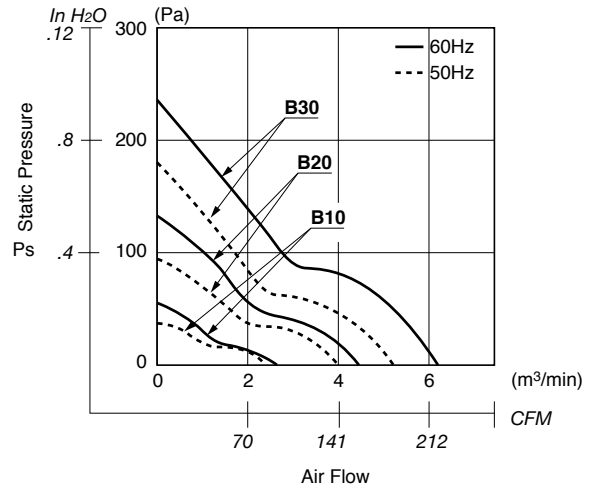
## Expected Life

Failure Rate: 10%  
25°C 50,000 Hours

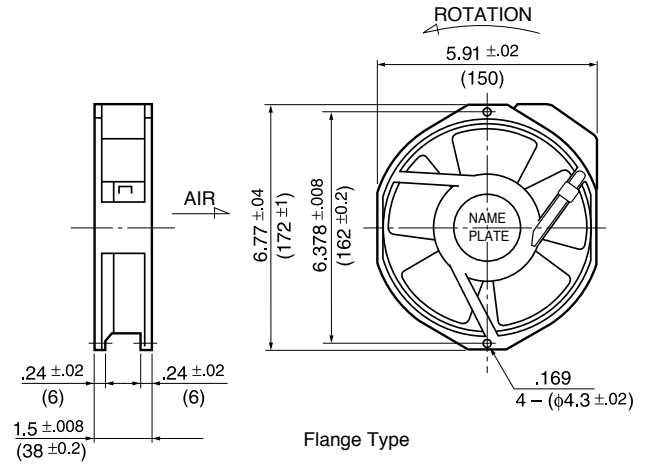
## Material

- Casing : Aluminum
- Impeller : Polycarbonate (Glass Fiber-Containing)
- Bearing : Ball Bearing
- Terminal : Faston #110 or equivalent

## Characteristic Curves

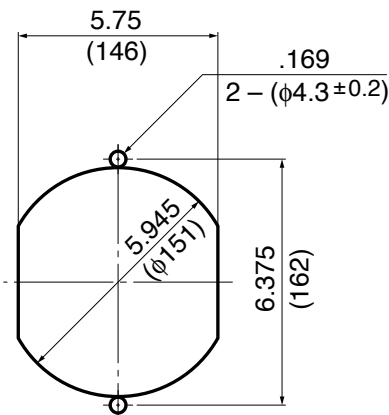


## Outline



## Panel Cut-Outs

Units:  $\frac{\text{inch}}{\text{mm}}$



INLET SIDE / OUTLET SIDE

## Specifications

AC Axial Fans

MODEL	Rated Voltage	Frequency	Starting Voltage	Current	Input Power	Speed	Max. Air Flow		Max. Static Pressure		Noise	Mass
	(V)	(Hz)	(V)	(A) <sup>1</sup>	(W) <sup>10% 20%</sup>	(min <sup>-1</sup> ) <sup>3</sup>	CFM	(m <sup>3</sup> /min) <sup>3</sup>	in H <sub>2</sub> O	(Pa) <sup>3</sup>	(dB) <sup>2</sup>	(g)
** 5915PC-10T-B30-B00	100	50	65	0.470	37.0	2700	176.5	5.00	.629	156.8	52.0	800
	100	60	65	0.440	33.0	3200	212.0	6.00	.865	215.6	56.0	800
5915PC-12T-B30-A00	115	50	75	0.380	35.0	2700	176.5	5.00	.629	156.8	52.0	800
	115	60	75	0.360	32.0	3200	212.0	6.00	.865	215.6	56.0	800
** 5915PC-20T-B30-B00	200	50	130	0.236	34.0	2700	176.5	5.00	.629	156.8	52.0	800
	200	60	130	0.210	33.0	3200	212.0	6.00	.865	215.6	56.0	800
** 5915PC-22T-B30-B00	220	50	145	0.210	40.0	2700	176.5	5.00	.629	156.8	52.0	800
	220	60	145	0.180	38.0	3200	212.0	6.00	.865	215.6	56.0	800
5915PC-23T-B30-A00	230	50	145	0.180	35.0	2700	176.5	5.00	.629	156.8	52.0	800
	230	60	145	0.190	35.0	3200	212.0	6.00	.865	215.6	56.0	800
** 5915PC-24T-B30-A00	240	50	155	0.180	34.0	2700	176.5	5.00	.629	156.8	52.0	800
	240	60	155	0.170	34.0	3200	212.0	6.00	.865	215.6	56.0	800
** 5915PC-10T-B20-B00	100	50	65	0.250	22.0	2200	141.2	4.00	.393	98.0	46.0	800
	100	60	65	0.230	23.0	2600	166.0	4.70	.472	117.6	50.0	800
5915PC-12T-B20-A00	115	50	75	0.200	21.0	2200	141.2	4.00	.393	98.0	46.0	800
	115	60	75	0.210	22.0	2600	166.0	4.70	.472	117.6	50.0	800
** 5915PC-20T-B20-B00	200	50	130	0.120	22.0	2200	141.2	4.00	.393	98.0	46.0	800
	200	60	130	0.140	23.0	2600	166.0	4.70	.472	117.6	50.0	800
** 5915PC-22T-B20-B00	220	50	145	0.110	23.0	2200	141.2	4.00	.393	98.0	46.0	800
	220	60	145	0.130	26.0	2600	166.0	4.70	.472	117.6	50.0	800
5915PC-23T-B20-A00	230	50	145	0.120	23.0	2200	141.2	4.00	.393	98.0	46.0	800
	230	60	145	0.140	26.0	2600	166.0	4.70	.472	117.6	50.0	800
** 5915PC-24T-B20-A00	240	50	145	0.100	22.0	2200	141.2	4.00	.393	98.0	46.0	800
	240	60	145	0.110	26.0	2600	166.0	4.70	.472	117.6	50.0	800
** 5915PC-10T-B10-B00	100	50	65	0.170	16.0	1400	84.7	2.40	.173	43.1	35.0	800
	100	60	65	0.020	18.0	1650	102.3	2.90	.243	60.7	38.0	800
5915PC-12T-B10-A00	115	50	75	0.160	16.0	1400	84.7	2.40	.173	43.1	35.0	800
	115	60	75	0.190	18.0	1650	102.3	2.90	.243	60.7	38.0	800
** 5915PC-20T-B10-B00	200	50	130	0.110	16.0	1400	84.7	2.40	.169	42.1	35.0	800
	200	60	130	0.130	18.0	1650	102.3	2.90	.243	60.7	38.0	800
** 5915PC-22T-B10-B00	220	50	130	0.100	16.0	1400	84.7	2.40	.169	42.1	35.0	800
	220	60	130	0.120	18.0	1650	102.3	2.90	.243	60.7	38.0	800
5915PC-23T-B10-A00	230	50	145	0.090	16.0	1400	84.7	2.40	.169	43.1	35.0	800
	230	60	145	0.110	18.0	1650	102.3	2.90	.243	60.7	38.0	800
** 5915PC-24T-B10-A00	240	50	145	0.090	16.0	1400	84.7	2.40	.169	42.1	35.0	800
	240	60	145	0.110	18.0	1650	102.3	2.90	.243	60.7	38.0	800

Rotation: Counterclockwise

Airflow Outlet: Air Out Over Struts

\*1: Maximum Values in Free Air

\*\* Contact NMB for Availability

\*2: Average Values in Free Air

\*3: Minimum Values in Free Air



## General Specifications

**Motor Structure:** Capacitor-Run Induction Motor  
**Motor Protection:** Thermal Protection  
**Insulation Resistance:**  
 10M Ω or over with a DC500V Megger  
**Dielectric Withstand Voltage:** AC 1800V 1s  
**Allowable Ambient Temperature Range:**  
 -10°C ~ +70°C (Operating)  
 -40°C ~ +70°C (Storage)  
 (non-condensing environment)

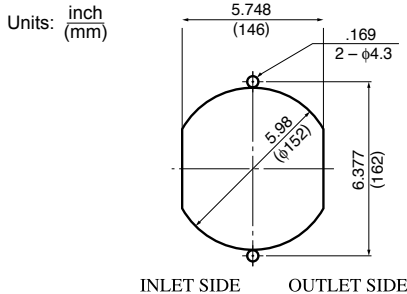
## Expected Life

**Failure Rate: 10%**  
 25°C 100,000 Hours

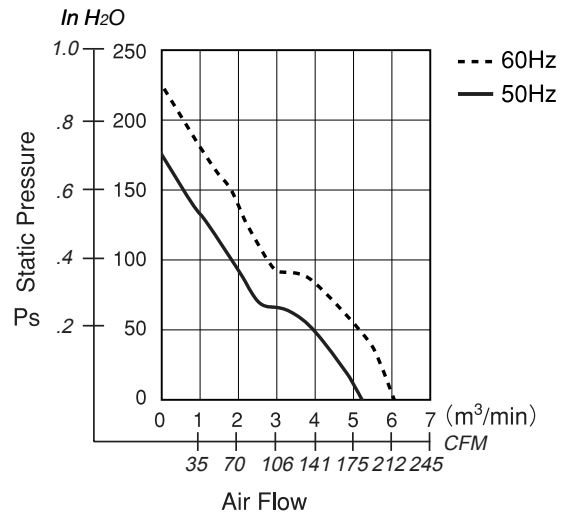
## Material

**Casing :** Aluminum  
**Impeller :** Polycarbonate (Glass Fiber-Containing)  
**Bearing :** Ball Bearing  
**Terminal :** Faston #110 or equivalent

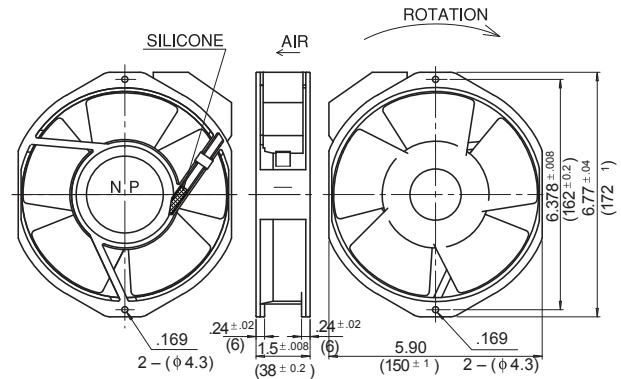
## Panel Cut-Outs



## Characteristic Curves



## Outline



## Specifications

MODEL	Rated Voltage	Frequency	Starting Voltage	Current	Input Power	Speed	Max. Air Flow		Max. Static Pressure		Noise	Mass
	(V)	(Hz)	(V)	(A) <sup>1</sup>	(W) <sup>1</sup>	(min <sup>-1</sup> ) <sup>3</sup>	CFM	(m <sup>3</sup> /min) <sup>3</sup>	in H <sub>2</sub> O	(Pa) <sup>3</sup>	(dB) <sup>2</sup>	(g)
** 5915PC-10T-B30-AM0	100	50	65	0.470	37.0	2700	176.5	5.00	0.628	157.0	52	850
** 5915PC-10T-B30-AM0	100	60	65	0.440	33.0	3200	211.8	6.00	0.863	215.8	56	850
5915PC-12T-B30-AM0	115	50	75	0.380	35.0	2700	176.5	5.00	0.628	157.0	52	850
5915PC-12T-B30-AM0	115	60	75	0.360	32.0	3200	211.8	6.00	0.863	215.8	56	850
** 5915PC-20T-B30-AM0	200	50	130	0.230	34.0	2700	176.5	5.00	0.628	157.0	52	850
** 5915PC-20T-B30-AM0	200	60	130	0.210	33.0	3200	211.8	6.00	0.863	215.8	56	850
** 5915PC-22T-B30-AM0	220	50	145	0.210	40.0	2700	176.5	5.00	0.628	157.0	52	850
** 5915PC-22T-B30-AM0	220	60	145	0.180	38.0	3200	211.8	6.00	0.863	215.8	56	850
5915PC-23T-B30-AM0	230	50	150	0.190	35.0	2700	176.5	5.00	0.628	157.0	52	850
5915PC-23T-B30-AM0	230	60	150	0.180	35.0	3200	211.8	6.00	0.863	215.8	56	850
** 5915PC-24T-B30-AM0	240	50	155	0.180	34.0	2700	176.5	5.00	0.628	157.0	52	850
** 5915PC-24T-B30-AM0	240	60	155	0.170	34.0	3200	211.8	6.00	0.863	215.8	56	850

Rotation: Counterclockwise  
 \*\* Contact NMB for Availability

Airflow Outlet: Air Out Over Struts

<sup>1</sup>: Maximum Values in Free Air  
<sup>2</sup>: Average Values in Free Air  
<sup>3</sup>: Minimum Values in Free Air

**General Specifications**

Motor Structure: Shaded Pole Induction Motor  
 Motor Protection: Impedance Protection  
 Insulation Resistance:  
 100M Ω or over with a DC500V Megger  
 Dielectric Withstand Voltage: AC 1800V 3s  
 Allowable Ambient Temperature Range:  
 -10°C ~ +60°C (Operating)  
 -40°C ~ +70°C (Storage)  
 (non-condensing environment)

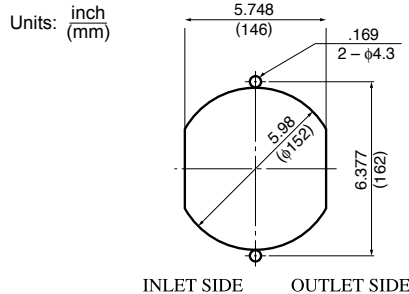
**Expected Life**

Failure Rate: 10%  
 25°C 50,000 Hours

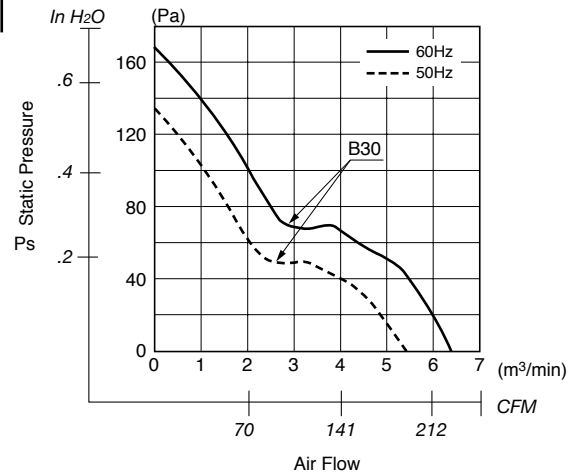
**Material**

Casing : Aluminum  
 Impeller : Steel  
 Bearing : Ball Bearing  
 Terminal : Faston #110 or equivalent

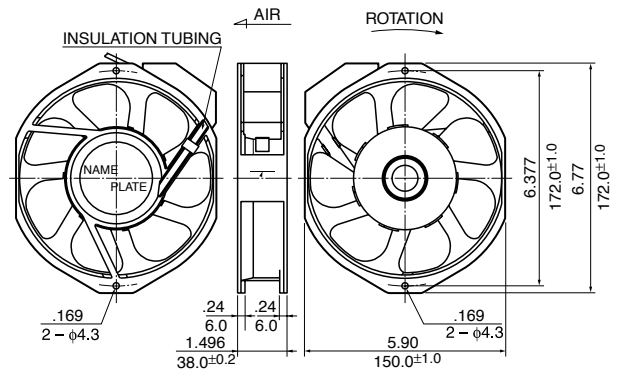
**Panel Cut-Outs**



**Characteristic Curves**



**Outline**



**Specifications**

MODEL	Rated Voltage	Frequency	Starting Voltage	Current	Input Power	Speed	Max. Air Flow		Max. Static Pressure		Noise	Mass
	(V)	(Hz)	(V)	(A) <sup>1</sup>	(W) <sup>1</sup>	(min <sup>-1</sup> ) <sup>3</sup>	CFM	(m <sup>3</sup> /min) <sup>3</sup>	in H <sub>2</sub> O	(Pa) <sup>3</sup>	(dB) <sup>2</sup>	(g)
** 5915PC-10T-B30-S00	100	50	65	0.530	42.0	2650	187.10	5.30	0.510	127.5	48	900
** 5915PC-10T-B30-S00	100	60	65	0.450	40.5	3150	222.39	6.30	0.655	163.8	53	900
5915PC-12T-B30-S00	115	50	75	0.450	40.0	2650	187.10	5.30	0.510	127.5	48	900
5915PC-12T-B30-S00	115	60	75	0.400	38.0	3150	222.39	6.30	0.655	163.8	53	900
** 5915PC-20T-B30-S00	200	50	130	0.250	42.0	2650	187.10	5.30	0.510	127.5	48	900
** 5915PC-20T-B30-S00	200	60	130	0.230	40.0	3150	222.39	6.30	0.655	163.8	53	900
** 5915PC-22T-B30-S00	220	50	145	0.250	42.0	2650	187.10	5.30	0.510	127.5	48	900
** 5915PC-22T-B30-S00	220	60	145	0.230	40.0	3150	222.39	6.30	0.655	163.8	53	900
5915PC-23T-B30-S00	230	50	150	0.220	42.0	2650	187.10	5.30	0.510	127.5	48	900
5915PC-23T-B30-S00	230	60	150	0.200	40.0	3150	222.39	6.30	0.655	163.8	53	900
** 5915PC-24T-B30-S00	240	50	155	0.200	39.0	2650	187.10	5.30	0.510	127.5	48	900
** 5915PC-24T-B30-S00	240	60	155	0.200	39.0	3150	222.39	6.30	0.655	163.8	53	900

Rotation: Counterclockwise      Airflow Outlet: Air Out Over Struts  
 \*\* Contact NMB for Availability

\*1: Maximum Values in Free Air  
 \*2: Average Values in Free Air  
 \*3: Minimum Values in Free Air

## General Specifications

**Motor Structure:** Capacitor-Run Induction Motor  
**Motor Protection:** Thermal Protection  
**Insulation Resistance:**  
 100M Ω or over with a DC500V Megger  
**Dielectric Withstand Voltage:** AC 1800V 3s  
**Allowable Ambient Temperature Range:**  
 -10°C ~ +60°C (Operating)  
 -40°C ~ +70°C (Storage)  
 (non-condensing environment)

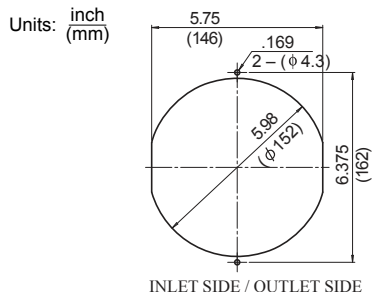
## Expected Life

**Failure Rate: 10%**  
 25°C 50,000 Hours

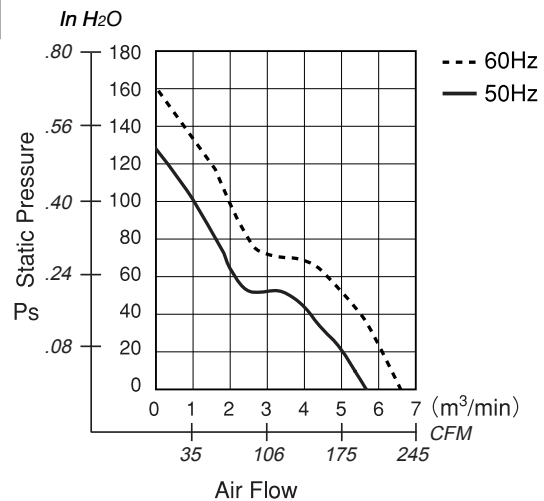
## Material

**Casing :** Aluminum  
**Impeller :** Steel  
**Bearing :** Ball Bearing  
**Terminal :** Faston #110 or equivalent

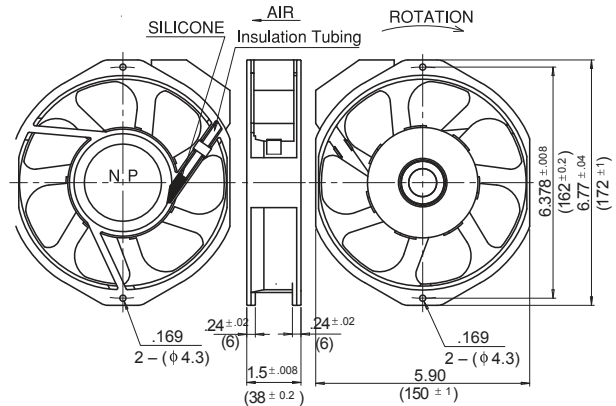
## Panel Cut-Outs



## Characteristic Curves



## Outline



## Specifications

MODEL	Rated Voltage	Frequency	Starting Voltage	Current	Input Power	Speed	Max. Air Flow		Max. Static Pressure		Noise	Mass
	(V)	(Hz)	(V)	(A) <sup>1</sup>	(W) <sup>1</sup>	(min <sup>-1</sup> ) <sup>3</sup>	CFM	(m <sup>3</sup> /min) <sup>3</sup>	in H <sub>2</sub> O	(Pa) <sup>3</sup>	(dB) <sup>2</sup>	(g)
5915PC-10T-B30-SM0	100	50	65	0.530	42.0	2650	187.10	5.30	0.510	127.5	48	950
5915PC-10T-B30-SM0	100	60	65	0.450	40.0	3150	222.39	6.30	0.655	163.8	53	950
5915PC-12T-B30-SM0	115	50	75	0.450	40.0	2650	187.10	5.30	0.510	127.5	48	950
5915PC-12T-B30-SM0	115	60	75	0.400	38.0	3150	222.39	6.30	0.655	163.8	53	950
5915PC-20T-B30-SM0	200	50	130	0.250	42.0	2650	187.10	5.30	0.510	127.5	48	900
5915PC-20T-B30-SM0	200	60	130	0.230	40.0	3150	222.39	6.30	0.655	163.8	53	950
5915PC-22T-B30-SM0	220	50	145	0.250	42.0	2650	187.10	5.30	0.510	127.5	48	900
5915PC-22T-B30-SM0	220	60	145	0.230	40.0	3150	222.39	6.30	0.655	163.8	53	950
5915PC-23T-B30-SM0	230	50	150	0.220	42.0	2650	187.10	5.30	0.510	127.5	48	950
5915PC-23T-B30-SM0	230	60	150	0.200	40.0	3150	222.39	6.30	0.655	163.8	53	950
5915PC-24T-B30-SM0	240	50	155	0.200	39.0	2650	187.10	5.30	0.510	127.5	48	950
5915PC-24T-B30-SM0	240	60	155	0.200	39.0	3150	222.39	6.30	0.655	163.8	53	950

Rotation: Counterclockwise

Airflow Outlet: Air Out Over Struts

\*1: Maximum Values in Free Air

\*2: Average Values in Free Air

\*3: Minimum Values in Free Air

FAN MODEL	UL E89936	CSA LR65829 DC Series Fan	VDE	TUV	CE
1004KL	Vol. I, S44	1087445	1507300-0023		X
1204KL	Vol. I, S37	1223044	1507300-0013		X
1404KL	Vol. I, S45	1065707	1507300-0032		X
1511FB	Vol. I, S116		1507300-0086		
1604KL	Vol. I, S40	1141408	1507300-0008		X
1606KL	Vol. I, S32	1255295	1507300-0008		X
1608KL	Vol. I, S32	1278193	1507300-0022		X
1608VL	Vol. I, S48		1507300-0048		X
1611FB	Vol. I, S111		1507300-0081		
1611FT	Vol. I, S115		1507300-0081		
1611KL	Vol. I, S86		1507300-0061		X
1611RL	Vol. I, S111		1507300-0081		X
1619FT	Vol. I, S115		1507300-0081		
1622VWB	Vol. I, S119		1507300-0081		X
1622FT	Vol. I, S115		1507300-0081		X
1910RL	Vol. I, S100		1507300-0081		X
2004KL	Vol. I, S43	1144468	1507300-0017		X
2006FL	Vol. I, S56	1124524	1507300-0042		X
2006ML	Vol. I, S96		1507300-0069		X
2106KL	Vol. I, S32	1255295	1507300-0018		X
2404KL	Vol. I, S61	1146135	1507300-0047		X
2406GL	Vol. I, S57	1124520			X
2406KL	Vol. I, S38	2500002888	1507300-0020		X
2406RL	Vol. I, S38		1507300-0031		X
2406VL	Vol. I, S38		1507300-0031		X
2408NL	Vol. I, S34	1309625	1507300-0013		X
2408VL	Vol. I, S34		1507300-0013		X
2410EL	Vol. I, S90		1507300-0010		X
2410ML	Vol. I, S33	1193855	1507300-0010		X
2410RL	Vol. I, S90		1507300-0064		X
2410SB	Vol. I, S33		1507300-0064		X
2415FB	Vol. I, S94		1507300-0067		
2415KL	Vol. I, S94		1507300-0067		X
2415RL	Vol. I, S94		1507300-0067		X
2806FL	Vol. I, S68	1243390	1507300-0056		X
2806GL	Vol. I, S84	1335659	1507300-0060		X
2806KL	Vol. I, S91	1475908	1507300-0060		X
2806RL	Vol. I, S97	1600957	1507300-0060		
2810KL	Vol. I, S65	1188649	1507300-0008		X
3106KL	Vol. I, S46	1038727	1507300-0033		X
3106RL	Vol. I, S93		1507300-0065		X
3108NL	Vol. I, S29	1309625	1507300-0016		X
3110EL	Vol. I, S35		1507300-0088		X
3110GL	Vol. I, S35		1507300-0008		X
3110KL	Vol. I, S35	1309625	1507300-0008		X
3110RL	Vol. I, S93		1507300-0065		X
3110SB	Vol. I, S33		1507300-0065		X
3112KL	Vol. I, S35	1309625	1507300-0008		X
3115FT	Vol. I, S115		1507300-0081		X
3115RL	Vol. I, S93		1507300-0065		X
3122FT	Vol. I, S115		1507300-0081		
3610EL	Vol. I, S31		1507300-0008		X
3610FL	Vol. I, S99		1507300-0072		X
3610GL	Vol. I, S31	1309625			
3610KL	Vol. I, S31	1309625	1507300-0008		X
3610RL	Vol. I, S93		1507300-0065		X
3610SB	Vol. I, S31		1507300-0008		X
3610VL	Vol. I, S31		1507300-0008		X
3612KL	Vol. I, S552	1253246	1507300-0008		X
3612VL	Vol. I, S552		1507300-0008		X
3615FB	Vol. I, S551		1507300-0008		X
3615KL	Vol. I, S551	1195298	1507300-0008		X
3615ML	Vol. I, S551		1507300-0008		X
3615RL	Vol. I, S551		1507300-0008		X
4515JL			1507300-0083		
4710KL	Vol. I, S64	1174022	1507300-0049		X
4710SL	Vol. I, S64				
4712FL	Vol. I, S55	1143199	1507300-0045		
4712KL	Vol. I, S41	1143199	1507300-0008		X
4715HL	Vol. I, S72				
4715JL			1507300-0083		
4715KL	Vol. I, S36	1557150	1507300-0008		X
4715RL	Vol. I, S36		1507300-0008		X
4715SL	Vol. I, S67	1197651	1507300-0058		X
4715VL	Vol. I, S36		1507300-0008		X
5015FL	Vol. I, S58		1507300-0024		X
5015KL	Vol. I, S58		1507300-0024		X



15073-3250-1001



Agency Approvals

FAN MODEL	UL E89936	CSA LR65829	VDE	TUV	CE
FBX14	Vol. I, S113				
5910PL	Vol. I, S74	1285829	1507300-0034		X
5920FT	Vol. I, S30		1507300-0044		
5920PL	Vol. I, S30	1285831	1507300-0044		X
5920SL	Vol. I, S30				
5920VL	Vol. I, S30		1507300-0044		
6820PL	Vol. I, S30	1285831	1507300-0044		X
6820FT	Vol. I, S30		1507300-0044		
6820SL	Vol. I, S30				
6820VL	Vol. I, S30		1507300-0044		
<b>DC Blowers</b>					
BM4212	Vol. I, S104		1507300-0076		
BM4515	Vol. I, S62	1161575	1507300-0046		X
BM4520	Vol. I, S104		1507300-0076		X
FAL3F	Vol. I, S114	99935			
BM5020	Vol. I, S105		1507300-0078		X
BM5115	Vol. I, S50	1057185	1507300-0030		X
BM5125	Vol. I, S53	1082756	1507300-0022		X
BM5712	Vol. I, S104		1507300-0076		X
BM5913	Vol. I, S104		1507300-0076		
BM6015		1082756			
BM6023	Vol. I, S103		1507300-0075		
BM6025	Vol. I, S103		1507300-0075		X
BM6625	Vol. I, S95		1507300-0066		X
BM6920	Vol. I, S95		1507300-0066		X
BG0702	Vol. I, S63	1133535			X
BG0703	Vol. I, S42	-158	1507300-0019		X
FAL5F	Vol. I, S114	099935			
BG0801	Vol. I, S98		1507300-0019		
BG0803	Vol. I, S66		1507300-0019		
BG0903	Vol. I, S59	1120644	1507300-0039		X
BG1002	Vol. I, S60	1158481			X
FAL6F	Vol. I, S114	099935			
BG1203	Vol. I, S49	1031559	1507300-0029		X
BG1402	Vol. I, S106		1507300-0029		
BG1504	Vol. I, S106		1507300-0029		
BL4447	Vol. I, S77				
BL4747	Vol. I, S49	-141			
BT1002	Vol. I, S101		1507300-0073		
<b>DC Motorized Impellers</b>					
175R Series	Vol. I, S87				X
I01R057D07	Vol. I, S109				
190R071D073XAXX	Vol. I, S80		1507300-0057		X
220R071D053XAXX	Vol. I, S107		1507300-0057		X
220R071D0731A01	Vol. I, S107		1507300-0057		X
220R071D0901A01	Vol. I, S107				
225R099D053XAXX	Vol. I, S107		1507300-0057		X
225R099D073XAXX	Vol. I, S107		1507300-0057		X
250R100D052XAXX	Vol. I, S80		1507300-0057		X
250R100D0701XXX	Vol. I, S80		1507300-0057		
250R100D072XAXX	Vol. I, S80		1507300-0057		
280R125D052XAXX	Vol. I, S71		1507300-0057		X
280R125D072XAXX	Vol. I, S71		1507300-0057		X
<b>AC Series Fan</b>					
2412PS	Vol. I, S3	1202307	1507300-1014		X
2415PS	Vol. I, S1	1202307			
3108PS	Vol. I, S1	1202307			
3110MS	Vol. I, S3		1507300-0078		X
3110PS	Vol. I, S3	1202307		R0030033	X
3115FS	Vol. I, S28	-19	1507300-0015	R0030030	X
3115PS	Vol. I, S3	1202307	1507300-0015	30781695	X
3610PS	Vol. I, S3	1202307	1507300-0006	30781695	X
3615HS	Vol. I, S118		1507300-0089		X
4710PS	Vol. I, S3	1202307	1507300-0009		X
4715FS	Vol. I, S27	1417267		30781695	X
4715HS	Vol. I, S10		1507300-0011		X
4715MS	Vol. I, S6	-10	1507300-0011	30781695	X
4715PS	Vol. I, S1	1202307	1507300-0011	30680496	X
4715TS	Vol. I, S10		1507300-0011		X
5915PC	Vol. I, S2	1202307	1507300-0012		X
<b>Wet Location Outdoor-Use Fans (AC)</b>					
4715HS-12T-B50-AMX	Vol. I, S10				
4715HS-23T-B50-AMX	Vol. I, S10				
5915PC-12V-B30-AMX	Vol. I, S2				
<b>Wet Location Outdoor-Use Fans (DC)</b>					
5920VL-05W-B7X-DRX	Vol. I, S30				
5920VL-07W-B7X-DRX	Vol. I, S30				



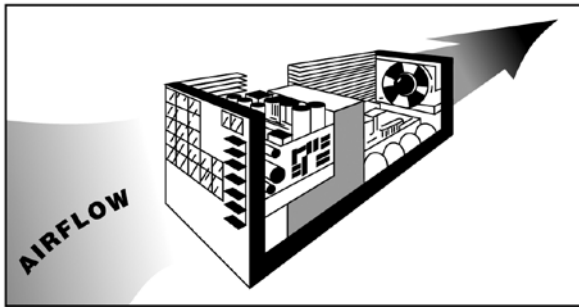
15073-3250-1001



**THERMAL DESIGN**

The need for forced-air cooling should be determined at an early stage in system design. It is important that the design plans for good airflow to heat-generating components and also allows adequate space and power for the cooling fan.

The first stage in designing a forced-air cooling system is to estimate the required airflow. This depends on the heat generated within the enclosure and the maximum temperature rise permitted.



**Enclosure with Cover Removed**

The airflow required can be obtained either by calculation or from a graph.

The equation for calculation is:

$$Q_1 = \frac{0.05 H}{\Delta T} \qquad Q_2 = \frac{1.76 H}{\Delta T}$$

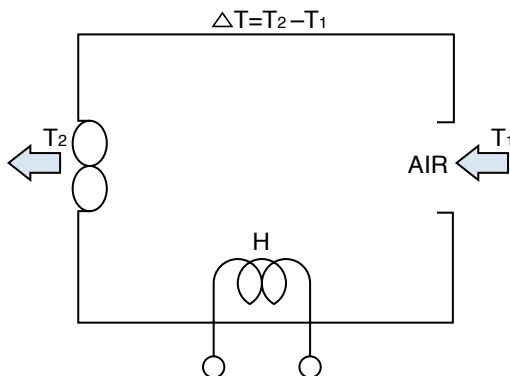
Where:

$Q_1$  = Airflow required in m<sup>3</sup>/min

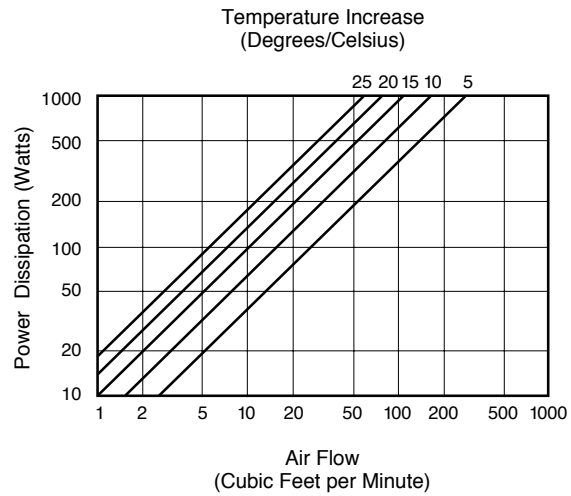
$Q_2$  = Airflow required in cubic feet/min

H = Heat dissipated in watts

$\Delta T$  = Temperature rise above inlet temp °C



In the following graph, the vertical axis represents the heat to be removed and the horizontal axis represents the airflow; both axes are logarithmic. The sloping lines define the temperature rise in °C. To use the graph, find the sloping line that represents the permitted temperature rise. Then, find the point on this line that corresponds to the heat to be removed. The horizontal position of this point shows the airflow required.



**Power Dissipation vs. Airflow for Various Temperature Increases**

**SYSTEM IMPEDANCE & OPERATING POINT**

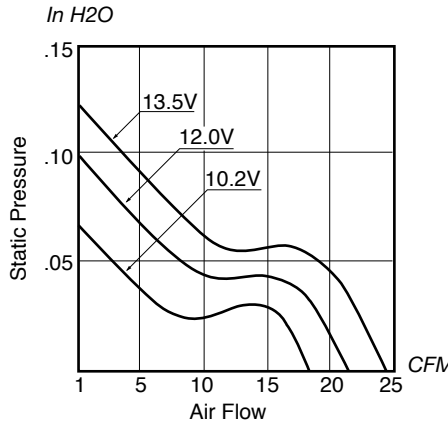
Obstructions in the airflow path cause static pressure within the enclosure. To achieve maximum airflow, obstructions should be minimized. However, obstructions in the form of baffles may be necessary to direct the airflow over the components that need cooling.

Chart 2.1 on the next page illustrates the nonlinear relationship between airflow and static pressure for a typical fan. The System Impedance curve, Chart 2.2, is a property inherent to an individual electronics enclosure. This curve can easily be generated experimentally, by testing the enclosure pressure at various airflow rates. The performance of a fan in a specific application is determined by the intersection of the System Impedance curve and the Fan Characteristic Curve, as shown on Chart 2.3.

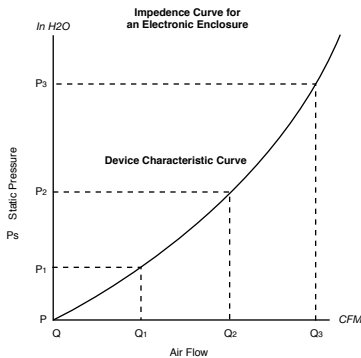
**SYSTEM IMPEDANCE & OPERATING POINT**  
(continued)

**Chart 2.1**

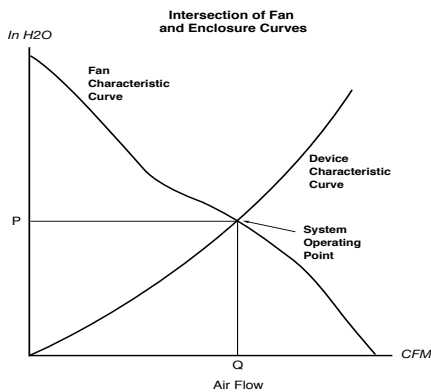
Typical relationship between Airflow and Static pressure for an Axial cooling fan.



**Chart 2.2**

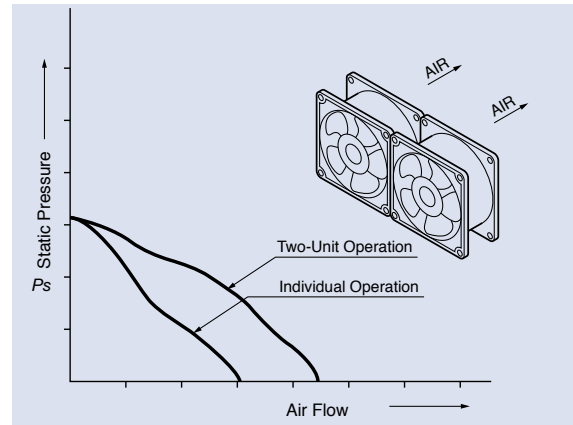


**Chart 2.3**

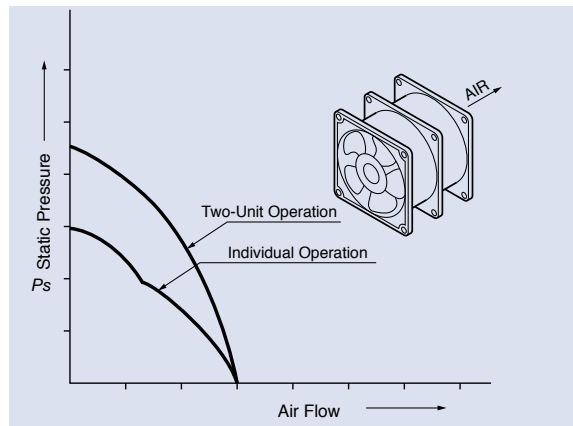


**MULTIPLE FAN USE**

The following figures show the performance characteristics for parallel and series operation of two identical fans.



**Parallel Operation**

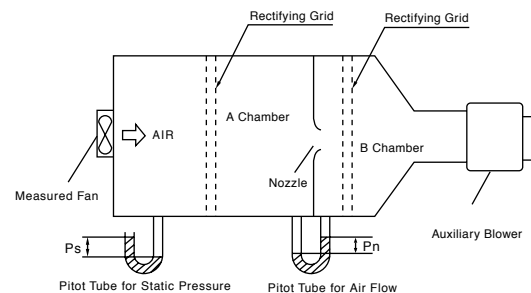


**Series Operation**

An additional fan in parallel to the first increases airflow in a low static pressure situation. An additional fan in series increases the airflow in a high static-pressure enclosure.

**AIRFLOW & PRESSURE MEASUREMENT**

An AMCA Standard 210 double chamber is used to accurately measure air volume and static pressure.



### AIRFLOW & PRESSURE MEASUREMENT (continued)

Maximum Static Pressure: When the nozzle is closed, the pressure in chamber A will reach maximum.

Maximum Airflow: When opening the nozzle and absorbing the air using the auxiliary blower to make the static pressure zero ( $P_s = 0$ ), the differential pressure ( $P_n$ ) between A chamber and B chamber will reach maximum. The airflow obtained by applying the differential pressure ( $P_n$ ) to the above equation can be called the maximum airflow.

Note: **Fan performance is calculated using the data obtained from this equipment according to the following formula:**

The Equation: Airflow

$$Q = 60 \cdot C \cdot \frac{\pi}{4} \cdot D^2 \sqrt{2g/r \cdot 0.10197 P_n} \text{ (m}^3\text{/min)}$$

- C: Coefficient of nozzle air
- D: Diameter of nozzle (m)
- r: Air density

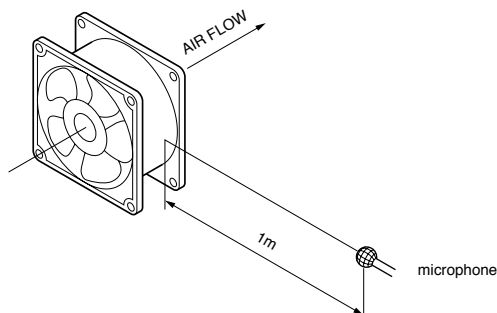
$$\left( 1.293 \times \frac{273}{273+t} \times \frac{P}{1013.25} \right) \text{ (kg/m}^3\text{)}$$

- t: Temperature ( $^{\circ}\text{C}$ )
- P: Air pressure (hPa)
- $P_n$ : differential pressure of air flow (Pa)
- g:  $9.8\text{m/s}^2$

### ACOUSTIC NOISE MEASUREMENT

Noise measurements are performed in an Anechoic Chamber with less than 16 dBA background noise in compliance with JIS C 9603 standards.

- DC Fan 1 m from inlet side
- AC Fan 1 m from the side



### FAN SENSORS

Three types of DC fan sensors are available for NMB fans:

Locked Rotor Signal – outputs the status of the fan motor and is ideal for detecting if the fan motor is rotating or stopped.

Tachometer Signal – set to produce two cycles of rectangular waveform as the fan motor makes one rotation and is ideal for detecting speed.

Life Signal – detects a reduction in fan speed at a specified RPM level.

#### Locked Rotor Alarm Signal:

Output Circuit: Open Collector

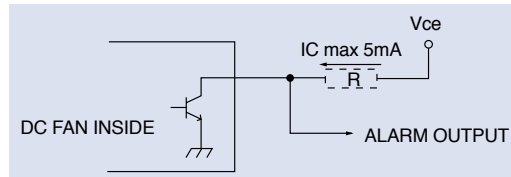
Specifications:

$V_{ce}$  max: +30V

$V_{ce}$  max: +15V (1004KL, 1404KL, 1204KL, 1604KL, 1606KL, 1608KL, 2004KL, 2106KL, 2406KL, BM4515, BM5115, BM5125, BM6015)

$I_c$  max: 5mA ( $V_{ce(sat)}$  max=0.4V)

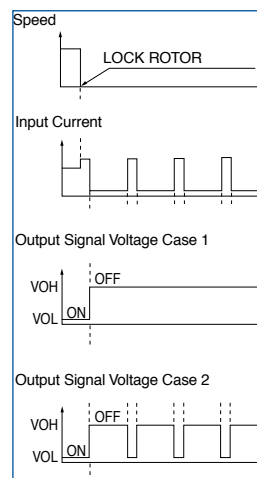
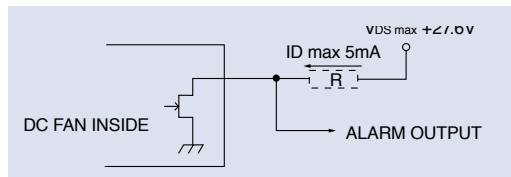
#### Alarm Signal Circuit



Alarm Signal Output: White, +:Red, -:Black

TTL output is an available option.

#### Alarm Signal Circuit



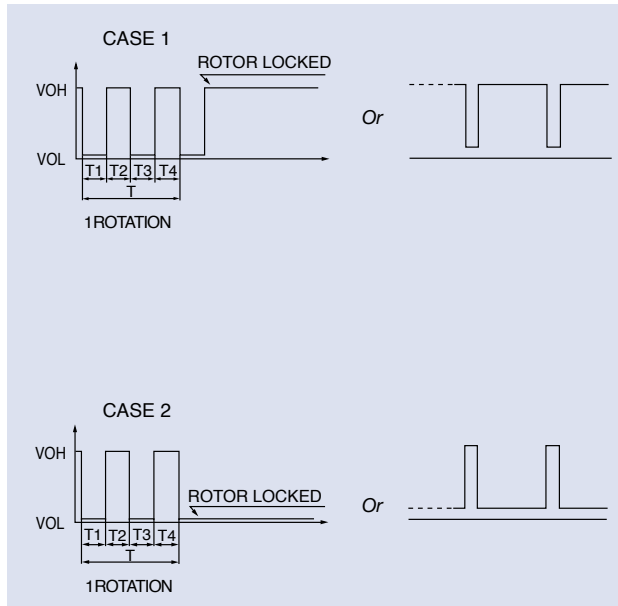
Output Waveform:

At Rated Voltage, the output signal may correspond to either Case 1 or Case 2. Your design should provide for both waveforms.



**Tachometer Signal**

Output Waveform: At Rated Voltage

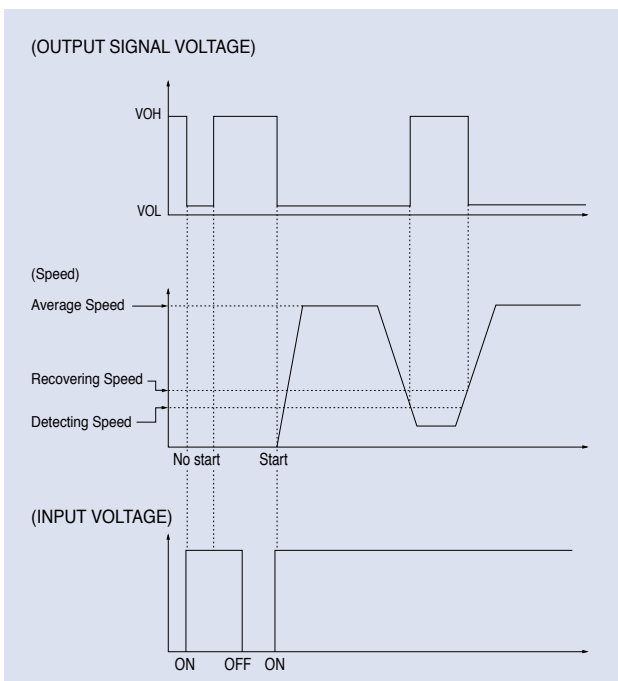


$T = T1 + T2 + T3 + T4 = 1 \text{ Rotation}$ ,  $T1 = T2 = T3 = T4 = 60/4m$   
 m: Rotation Speed  $\text{min}^{-1}$

The output signal may correspond to Case 1 or Case 2. Your design should provide for both waveforms.

**Life Signal**

Output Waveform: At Rated Voltage



**SPEED CONTROL**

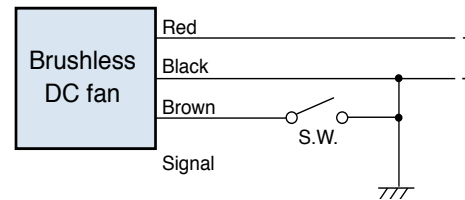
DC fan speed can be controlled in order to optimize cooling, reduce noise and decrease system power draw. There are various methods of controlling fan speed.

**2-speed DC fan motor**

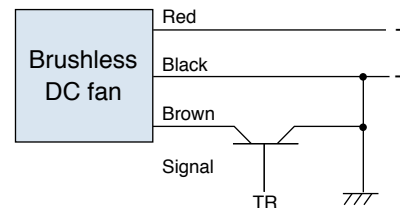
NMB's custom 2 speed fans are available with high and low speeds specified by the customer. The low end operating speed is fixed in order to reduce noise and lower power consumption.

Below is an example of an External connection for a 2-speed DC fan motor.

Control by relay contact



Control by transistor



Switch-over of fan speed

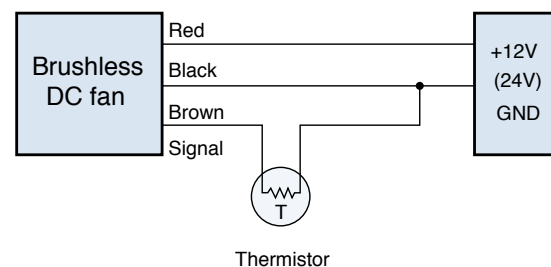
S.W. OFF: LOW SPEED, ON: HI SPEED

**Temperature Detecting Variable Speed DC Fan**

The RPM may be automatically controlled and synchronized with temperature variation by installing a thermistor.

Varying the control voltage (0 to 6V) enables speed variation between the signal wire and ground.

Example of connection diagram:

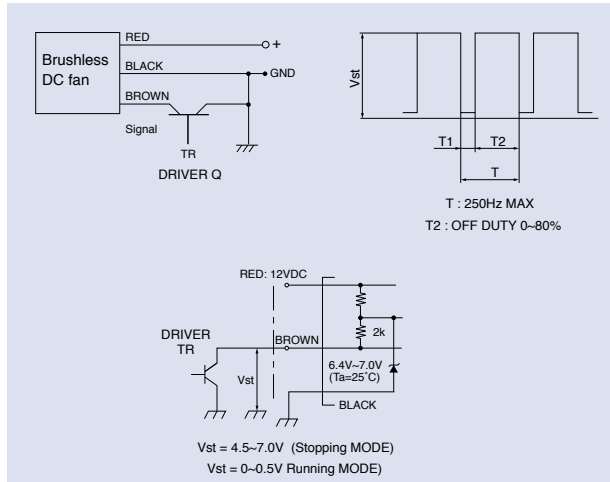


### PWM Control DC Fan

In PWM speed control, a fixed frequency square wave is applied to the speed control leadwire of the fan.

The ratio of on time vs. off time (duty cycle) is directly proportional to the speed of the fan.

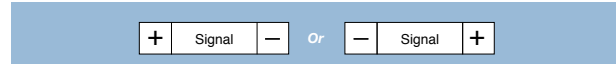
Example:



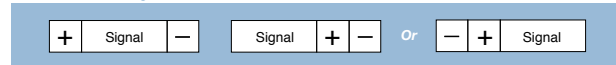
### Correct Signal Connection

Correct signal connection is important to prevent damage to the internal fan IC. Connection should be design as shown below:

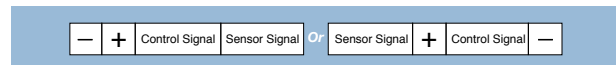
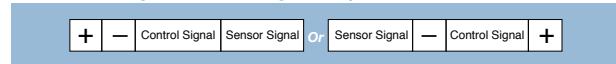
#### Signal Output



#### RPM Control Signal



#### RPM Control Signal & Sensor Signal Output



### FAN LAWS

There are various laws useful in determining different fan performance parameters. We have selected a few of these that can be useful in calculating airflow (CFM), pressure (inches H<sub>2</sub>O), power consumption (Watts), and noise (dBA), when operating at differing speeds (RPM).

Only fans of the same physical dimensions, same motor and impeller should be used for comparative analysis. The variables below are used in the formulas that follow:

Where:

- Speed<sub>k</sub> = Known Speed
- Speed<sub>n</sub> = The new speed we are using for calculation
- Airflow<sub>k</sub> = Known airflow at Speed<sub>k</sub>
- Airflow<sub>n</sub> = New airflow calculated at new speed
- Pressure<sub>k</sub> = Known Pressure at Speed<sub>k</sub>
- Pressure<sub>n</sub> = New pressure calculated at new speed
- Power<sub>k</sub> = Known Power at Speed<sub>k</sub>
- Power<sub>n</sub> = New Power calculated at new speed
- Noise<sub>k</sub> = Known Noise at Speed<sub>k</sub>
- Noise<sub>n</sub> = New Noise calculated at new speed

#### Calculating Airflow at different speeds:

$$\text{Airflow}_n = \text{Airflow}_k \left( \frac{\text{Speed}_n}{\text{Speed}_k} \right)$$

#### Calculating Pressure at different speeds:

$$\text{Pressure}_n = \text{Pressure}_k \left( \frac{\text{Speed}_n}{\text{Speed}_k} \right)^2$$

#### Calculating Power Draw at different speeds:

$$\text{Power}_n = \text{Power}_k \left( \frac{\text{Speed}_n}{\text{Speed}_k} \right)^3$$

#### Calculating Noise at different speeds:

$$\text{Noise}_n = \text{Noise}_k + 50 \log \left( \frac{\text{Speed}_n}{\text{Speed}_k} \right)^2$$

### Airflow Calculation Example:

If a fan provides 210 CFM of airflow at 3000 RPM. What airflow (CFM) would be expected if the speed (RPM) is increased to 3500 RPM?

- Speed<sub>k</sub> = 3000 RPM
- Airflow<sub>k</sub> = 210 FM
- Speed<sub>n</sub> = 3500 RPM

$$\text{Airflow}_n = \text{Airflow}_k \left( \frac{\text{Speed}_n}{\text{Speed}_k} \right)$$

$$\text{Airflow}_n = 245 \text{ CFM}$$

### Pressure Calculation Example:

In the example above the fan provides 0.1 inches of H<sub>2</sub>O Pressure at the system operating point. What pressure would be expected if the fan speed were increased to 3500 RPM?

Speed\_k = 3000 RPM  
 Speed\_n = 3500 RPM  
 Pressure\_k = 0.1 in H<sub>2</sub>O

$$\text{Pressure}_n = \text{Pressure}_k \left( \frac{\text{Speed}_n}{\text{Speed}_k} \right)^2$$

Pressure\_k = 0.136 in H<sub>2</sub>O

### Power Calculation Example:

The fan in question draws 22 Watts at 3000 RPM. What power draw would be expected if the fan speed were increased to 3500 RPM?

Speed\_k = 3000 RPM  
 Speed\_n = 3500 RPM  
 Power\_k = 22 watt

$$\text{Power}_n = \text{Power}_k \left( \frac{\text{Speed}_n}{\text{Speed}_k} \right)^3$$

Power\_n = 34.935 watt

### Noise Calculation Example:

The fan in question generates 58 dBA of noise measured 1 meter from the inlet side of the fan. What would the increase in noise be if the the speed were increased form 3000 RPM to 3500 RPM?

Speed\_k = 3000 RPM  
 Speed\_n = 3500 RPM  
 Noise\_k = 58 dBA

$$\text{Noise}_n = \text{Noise}_k \left( \frac{\text{Speed}_n}{\text{Speed}_k} \right)$$

Noise\_n = 61.347 dBA

## NMB TECHNICAL SUPPORT

NMB offers a full range of application and design support services, including thermal modeling and flow analysis. For assistance with any technical issue, please contact the NMB Fan Team through our web site at [www.nmbtc.com](http://www.nmbtc.com) or e-mail us at [fans@nmbtc.com](mailto:fans@nmbtc.com).

## UNITS OF MEASURE AND CONVERSIONS

Fan airflow, static pressure, temperature, and dimensions are often referred to in a variety of unit measures. Below are the measures and methods of conversion.

### Airflow

CFM	m <sup>3</sup> /min	m <sup>3</sup> /hr	L/sec
1	0.028	1.7	0.47
35.3	1	60	16.7
0.59	0.017	1	0.28
2.12	0.06	3.6	1

Example: To convert from CFM to m<sup>3</sup>/hr, multiply by 1.7

### Static Pressure

in H <sub>2</sub> O	mm H <sub>2</sub> O	Pa
1	25.4	249
0.039	1	9.81
0.004	0.1	1

To convert PA to H<sub>2</sub>O, multiply by 0.004

### Temperature

Degree F = 9/5 C + 32

Degree K = C + 273/15

### Linear Dimensions

1mm = 0.0394" ~ 0.04

1" = 25.4mm = 2.54 cm

1U = 44.4 mm = 1.75"

## FAN LIFE AND RELIABILITY

### Fan Life Testing

Life expectancy of a cooling fan is a critical element in thermal design. NMB uses parametric failure modes during life testing to calculate for life expectancy. Speed (RPM) and Current (mA) failures include both “hard failures” (where the fan is non-functional) and “parametric failures”. These parametric failures are defined as 15% decrease in RPM and an increase in mA of 15%.

Including parametric failure modes leads to a more conservative L-10 and MTTF reporting standard than those methods that measure life performance using only hard failures.

The benefit to the customer is a fan that sets the quality and reliability standard for the cooling industry.

NMB evaluates fan life and reliability during the design phase using accelerated life testing in conjunction with ORT (Ongoing Reliability Testing). Accelerated life testing is used to compress the amount of time required to conduct life testing. Development testing occurs early in the product design, prior to product release. It is vital to characterize the reliability of the product in the initial stages of design to allow for improvements and to meet the reliability specifications prior to release to manufacturing.

Once the design has been through design verification testing and is turned over to manufacturing, ORT is conducted. For some models, ORT evaluation has continued beyond 10 years. The value of ORT is a continued refinement of the accuracy of the accelerated life testing and constant review of the design of the fan. This continued process improvement allows for ongoing evaluation and increase in fan life and reliability.

Under accelerated life testing NMB fans are tested at extreme environmental conditions, with temperature stress factors above standard operating levels. In order to gather meaningful data within a reasonable time frame, the stress factors must be accelerated to simulate different operating environments. High temperature stress is the most common stress factor used for these purposes.

Proper understanding of accelerating stresses and design limits are necessary to implement a meaningful accelerated reliability test. NMB uses the Arrhenius model for determining acceleration factors (AF) during life testing. This is the most commonly used model in accelerated life testing where thermal stress is the primary factor affecting life.

Life test data gathered from different types of fans and blowers lends to highly accurate statistical analysis. This data can produce very detailed information about the behavior of the product for reliability and prediction of fan performance in the field. The Weibull Distribution is a typical method employed by NMB for statistical analysis. An explanation of this calculation model is shown below.

### Arrhenius Weibull Model:

Life Stress Relation: Arrhenius

The Arrhenius life-stress relationship is given by:

$$\eta = L(V) = C \cdot e^{\frac{\beta}{V}}$$

Where:

- L represents a quantifiable life measure, which is the scale parameter or characteristic life of the Weibull Distribution.
- V represents the stress level (formulated for temperature and temperature values in absolute units, i.e. degrees Kelvin or degrees Rankine)
- C is one of the model parameters to be determined (  $C > 0$  ).
- B is another model parameter to be determined

### Mean Life or MTTF

The mean,  $\bar{T}$ , also called MTTF or Mean Time To Failure, of the Arrhenius-Weibull relationship is given by:

$$\bar{T} = C \cdot \frac{B}{eV} \cdot T \left( \frac{1}{\beta} + 1 \right)$$

## Reliable Life

The Arrhenius Weibull Distribution model predicts the length of time at which a defined percentage of a product population will still be operating without failing to meet pre-set criteria. For cooling fans, this is normally characterized as L10 life expectancy, or the time at which 10% of a population will have failed and 90% of a population will continue to operate within specifications.

For the Arrhenius-Weibull relationship, the reliable life, TR, of a unit for a specified reliability and starting the mission at age zero is given by:

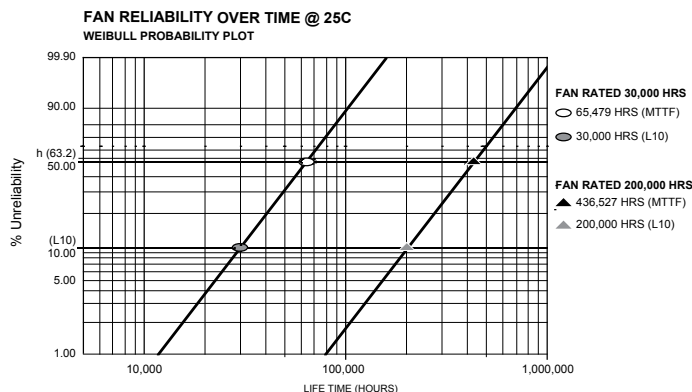
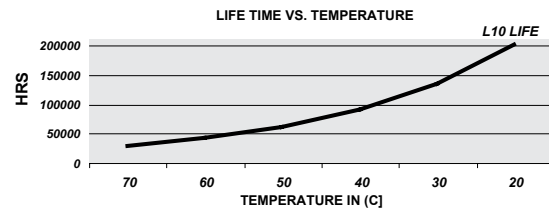
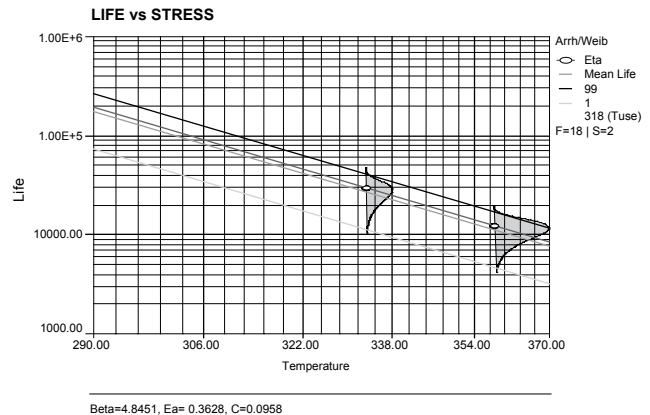
$$T_R = C \cdot \frac{B}{eV} \{-\ln[R(T_R, V)]\} \frac{1}{\beta}$$

This is the life for which the unit will function successfully with a reliability of R(TR). If R (TR) = 0.90 then TR = 90% reliability or 10% unreliability (L10) or the life by which 90% of the units will survive.

NMB uses parametric failure modes, or the condition at which a performance parameter fails to meet pre-set criteria, to record failures during accelerated life testing. This produces a more accurate prediction of field reliability than methods which use only non-operating failure modes to record failures.

Example: Life Experiment Data Using Arrhenius Weibull

Product L10 life expectancy for NMB fans ranges from 30,000 hours to 200,000 hours of continuous operation at room temperature depending on fan speed, frame size, design structure, size of ball bearings and the type of ball bearings used. NMB, a world leader in miniature precision ball bearings design and manufacturing, uses high quality, long life bearings produced in house to ensure extended fan life.



$\beta_1=2.50, \eta_1 = 73798.94$

$\beta_2=2.50, \eta_2=491992.91$

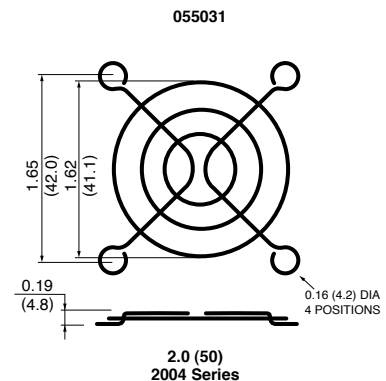
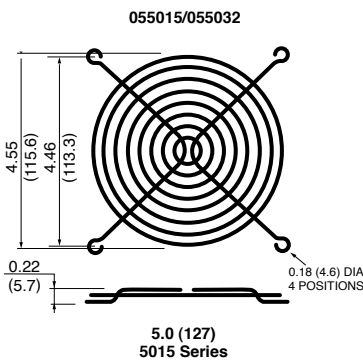
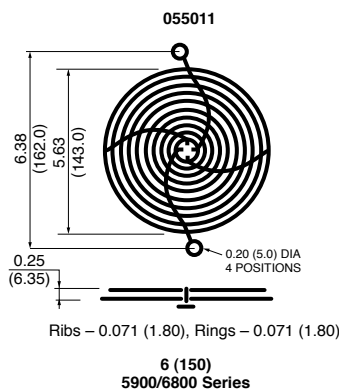
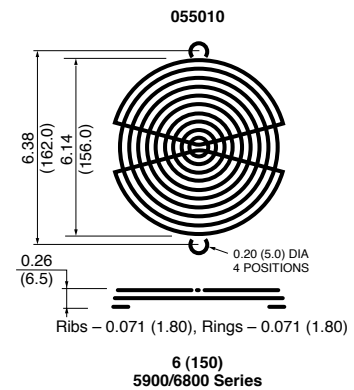
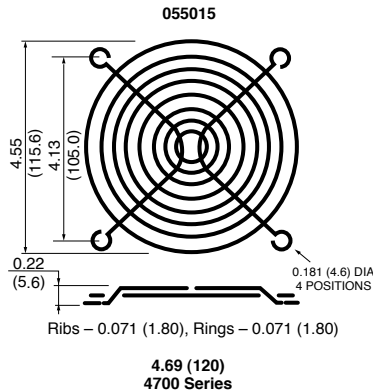
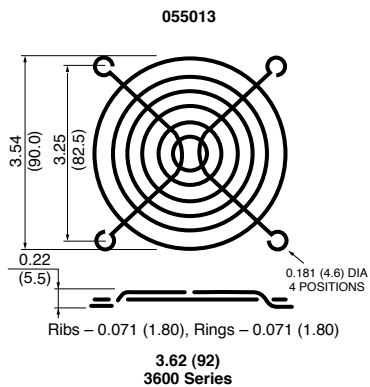
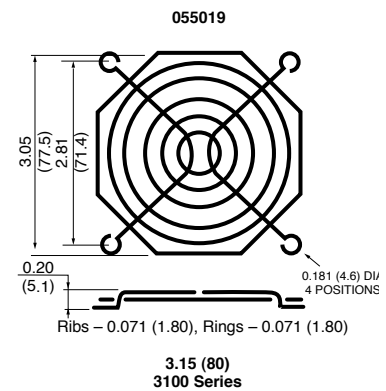
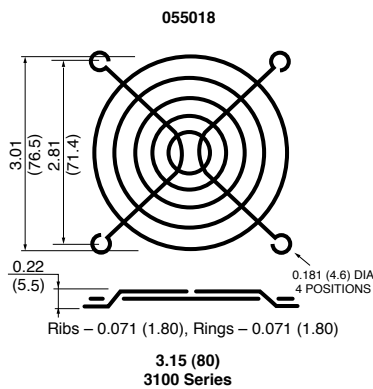
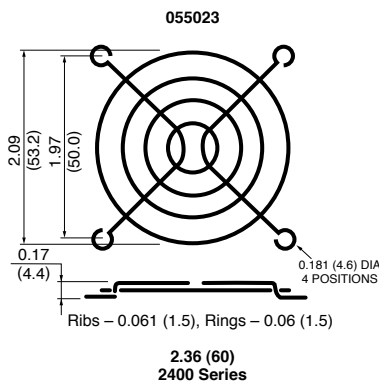
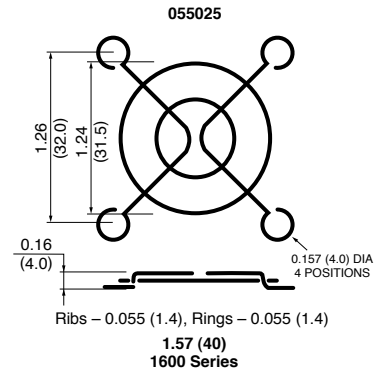
L10 - (10% Unreliability or 90% Reliability Over Time)

MTTF - (Mean Time To Failure or Mean Life)

For specific product life and reliability, please contact NMB's Applications Engineers.

**Fan Guards**

- Designed to insure safety
- Plating bright nickel chrome, black electro deposit available
- Plating thickness of .0005 min.
- Weld joints withstand 230 lbs. separation force
- Wire base C1010 steel



## Fan Guards/Mounting Clips/Cord Sets

Fan Mode	Fan Guards Part Number										Mounting Clips Part Number			Cord Sets Part Number		
	055010	055011	055013	055015	055018	055019	055023	055025	055031	055032	512011	512020	512023	432000	432002	432021
1004KL																
1204KL																
1404KL																
1604KL																
1606KL																
1608KL																
2004KL																
2106KL																
2406KL																
2408NL																
2410ML																
2410ML Vented																
3108NL																
3110KL																
3112KL																
3610KL																
3610KL Vented																
3612KL																
3615KL																
4710KL																
4712KL																
4715KL																
4715SL																
5015KL																
5020KL																
5910PL																
5920PL																
6820PL																
2412PS																
3110PS																
3115FS																
3115PS																
3610PS																
4710PS																
4715FS																
4715MS																
5915PC																

### ***NMB Fan Warranty Policy***

NMB warrants our fans to be free from defects in material and workmanship for a period of one (1) year. In order to accommodate transportation and installation we extend this warranty to 15 months from the date of manufacture.

This warranty applies to fans and blowers which are used within the design parameters and when used in an approved application. If there are any questions regarding proper application please contact your NMB representative and an applications engineer can review the customer's operational requirements.

### ***Warranty Limitations and Liability***

In the event of an operational failure of an NMB fan or blower, which was used in a manner specifically approved by NMB, NMB will at its option, repair or replace the defective fan or blower with an identical or functionally equivalent product.

In no case will NMB's liability exceed the purchase price of the defective product.

#### ***Errors***

All information, data and dimension tables in this catalog have been carefully compiled and thoroughly checked. However, no responsibility for possible errors or omissions can be assumed.

#### ***Changes***

The company reserves the right to change specifications and other information included in this catalog without notice.



# Additional Products From NMB

## Small Motors

NMB's small motor products include a line of hybrid and permanent magnet stepper motors, as well as NMB's brush and brushless DC motors. The brush DC motor line is ideal for applications that require small size and excellent power output. The brushless DC line is perfect for applications where

## Mechanical Bearing Assemblies

NMB's Miniature Precision Ball Bearings are the first component of a highly successful design of a mechanical bearing assembly. Machined components such as magnets, gears, molded and machine plastic parts, die cast parts and special materials are



the environment is sensitive to interference, battery powered equipment and clean room. Standard NMB hybrid and permanent magnet stepper motors are available, as well as many customizable features for your unique application.

For more information on our motor products, e-mail us at: [motors@nmbtc.com](mailto:motors@nmbtc.com)

## Miniature Precision Bearings

Our miniature bearings range in sizes from .1181 to 1.000 inch O.D. (3mm to 26mm), and are available in inch and metric sizes. Stainless steel or chrome steel bearings are available with crown or ribbon type metallic cages, as well as plastic crown type cages. NMB bearings are found in medical equipment, advanced automotive applications and household electrical appliances such as air conditioners, vacuum cleaners, VCRs and video cameras, and in motors for electronic controls systems, among others.

For more information on our miniature bearings, e-mail us at: [bearings@nmbtc.com](mailto:bearings@nmbtc.com)

designed and manufactured to work precisely with NMB precision ball bearings. Complex mechanical bearing assemblies are custom made to your design specifications, and are ideal for medical, office automation, and currency machines, as well as factory and lab automation applications.

For more information on our mechanical assembly products, e-mail us at: [assemblies@nmbtc.com](mailto:assemblies@nmbtc.com)

## Fan Trays

NMB's extensive selection of AC and DC cooling fans, as well as the latest range of high efficiency motorized impellers are your turn-key solution for your custom fan tray designs. NMB's fan tray product offerings include single or multiple devices, redundant and single-point of failure proof design, intelligent and self regulated control functions, two way communication with system for remote access and wide voltage range design.

For more information on our custom fan trays e-mail us at: [info@nmbtc.com](mailto:info@nmbtc.com)





ISO 14001 • ISO 9001:2008 • TS 16949 • OHSAS 18001

## ***NMB Technologies Corporation***

### North America

#### **Corporate Headquarters**

9730 Independence Avenue

Chatsworth, CA 91311

P: 818-341-3355, F: 818-341-8207

E: [info@nmbtc.com](mailto:info@nmbtc.com)

[www.nmbtc.com](http://www.nmbtc.com)

*Represented by:*

### International Sales Offices

Shanghai, China

Chennai, India

Bracknell, England

Baillet en France, France

Langen, Germany

Kowloon, Hong Kong

Milan, Italy

Tokyo, Japan

Kuala Lumpur, Malaysia

Manila, Philippines

Singapore

Seoul, South Korea

Taipei, Taiwan

Bangkok, Thailand

Hanoi, Vietnam