

## 金属軸18形ボリューム

## 18mm Size Metal Shaft Potentiometers

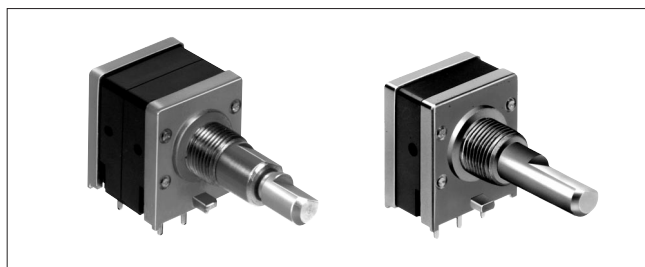

## ■ 特長

- デジタルオーディオの要求に応え、クロストーク特性、相互偏差特性の充実を図った、オーディオ用ボリュームです。
- 端子材質などの非磁性化、抵抗インクの改善による高音質タイプのボリュームです。

## ■ 用途

- オーディオアンプなどの音量、音質およびバランスコントロール

## ■ Features

- Crosstalk characteristic ideal for digital audio sets. Potentiometer for audio use with full-fledged gang error, etc.
- High quality sound type potentiometer realized by the use of non-magnetic terminal material and improved resistance ink.

## ■ Applications

- Volume, tone and balance control of audio amplifier etc.

## ■ 製品一覧 Products Line

タイプ Type	製品名 Model	取付高さ Mounting height (mm)	クリックバラエティ Detent variety	相互偏差 Gang error (dB)
1 軸単連 Single-shaft, single-unit	RK18111	12.5	センタクリック Center detent	-60dB~0dB ・ 3dB 以内 但し抵抗値、 変化特性により -80dB ~ -60dB ・ 5dB 以内可 -60dB to 0dB within 3dB Depending on resistance and taper, -80dB to -60dB within 5dB possible
1 軸2連 Single-shaft, dual-unit	RK18112		センタクリック Center detent	
1 軸4連 Single-shaft, quad.-unit	RK18114		11 21	
2 軸2連 Dual-shaft, dual-unit	RK18122		センタクリック Center detent	

■ 注記  
Notes

1. 2軸2連タイプはフリクション付きも対応可能です。
  2. 上記以外の仕様はP.93, P.94をご参照ください。
1. The double-shaft, double unit type is available with friction.
  2. For specifications other than those mentioned above, see page 93 and 94.

## ■ 軸受とシャーシ止寸法 Dimensions of bushing and fixing lug Unit : mm

適用 Applications	1 軸, 2 軸 Single-shaft, dual-shaft
Bushing	M9X0.75
Locating lug	

■ 軸の標準寸法 Standard dimensions of shaft

1. 1軸タイプ Single-shaft type

1) セレーション Knurled type

Unit : mm

L <sub>1</sub>	l <sub>1</sub>	d <sub>1</sub>	S <sub>1</sub>
15	5	1	6
20	10	1	11
25			
30	12	4	14

Not specified slotting angle

Shaft shown in full CCW position

- セレーションの山角度  
セレーション山角度は上図によります。
- Angle of serration.  
The angle of serration shall be as shown.

2) 平形 Flat type

Unit : mm

L <sub>1</sub>	l <sub>1</sub>
15	7
20	12
25	12
30	12

Shaft shown in full CCW position

3) 溝軸 Slotted type

Unit : mm

L <sub>1</sub>
10
15
20
25
30

Not specified slotting angle

注記  
Note





- ※    部が当社推奨仕様です。
- ※    shows the specification recommended by ALPS.

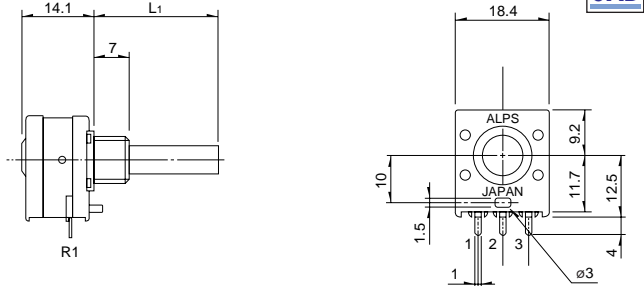

1 軸タイプ Single-shaft type

Unit : mm

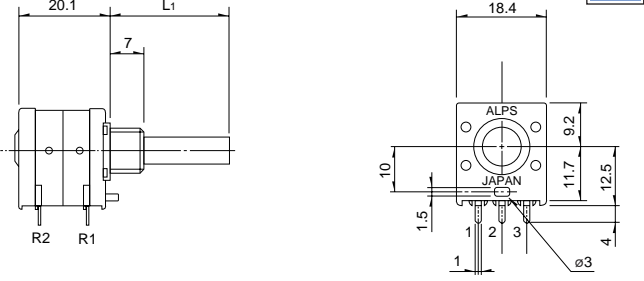
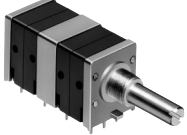
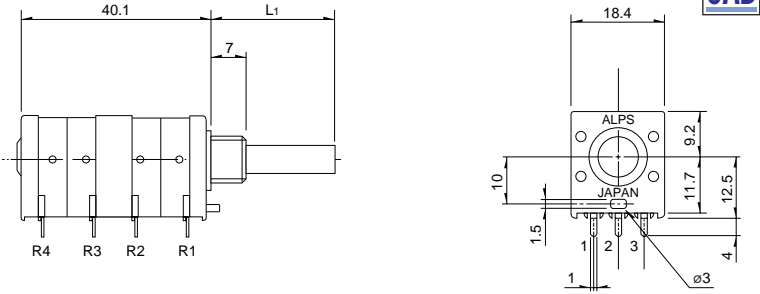
3

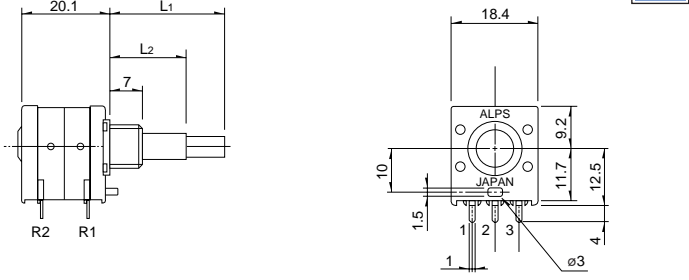
製品名 Model	外形図 Dimensions
<p>単連 Single-unit RK18111</p>  <p>最小包装単位 Minimum packing unit 100 pcs.</p>	
<p>1 軸 2 連 Single-shaft, dual-unit RK18112</p>  <p>最小包装単位 Minimum packing unit 100 pcs.</p>	
<p>1 軸 4 連 Single-shaft, quad.-unit RK18114</p>  <p>最小包装単位 Minimum packing unit 100 pcs.</p>	
<p>2 軸 2 連 Dual-shaft, dual-unit RK18122</p>  <p>最小包装単位 Minimum packing unit 100 pcs.</p>	

## 16形、18形、27形、40形、50形金属軸ボリューム共通仕様

Common Specifications for 16mm Size, 18mm Size, 27mm Size, 40mm Size, 50mm Size Metal shaft Potentiometers

## 電气的性能 Electrical characteristics

項目 Items	タイプ Type	RK16	RK18	RK27	RK40	RK50
		16mm size	18mm size	27mm size	40mm size	50mm size
全抵抗値 Total resistance	(kΩ)	1, 5, 10, 20, 50, 100, 200, 250, 500, 1000, 2000	10, 20, 50, 100, 200, 250			10, 20, 50, 100
全抵抗値許容差 Total resistance tolerance		±20%				
抵抗変化特性 Resistance taper		A, B, B (Vol.), C, D, E, K, W, RD, M, N		個別仕様による See individual specifications		
定格電力 Ratings power		Bカーブ B taper :0.1W Bカーブ以外 Other than B taper : 0.05W				0.1W
最高使用電圧 Maximum operating voltage	For AC use	150V AC		30V AC		150V AC
	For DC use	※20V DC	5V DC	—————		—————
残留抵抗 Residual resistance		R ≤ 10kΩ 20Ωmax. 10kΩ < R ≤ 50kΩ 30Ωmax. 50kΩ < R 公称全抵抗値の0.1%以下 0.1% or less of normal total resistance		R ≤ 10kΩ 20Ωmax. 10kΩ < R < 50kΩ 30Ωmax. 50kΩ ≤ R 公称全抵抗値の0.1%以下 0.1% or less of normal total resistance		—————
最大減衰量 (音量用) Maximum attenuation level for volume control		5kΩ ≤ R < 10kΩ 10kΩ ≤ R < 50kΩ 50kΩ ≤ R < 100kΩ 100kΩ ≤ R	70dB min. 80dB min. 90dB min. 100dB min.	(RK18は80dB min.) (RK18は90dB min.) (RK18は100dB min.) (RK18は110dB min.)		120dB min.
挿入損失 (音量用) Insertion loss for volume control		0.1dB max.				
相互偏差 Gang error	音量用 For Volume	-40dB to 0dB 3dB max.	-60dB to 0dB 3dB max.	-60dB to 0dB 2dB max.	-100dB to 0dB 3dB max.	
	音質用 For Tone	2dB max. at 50% rotation angle				—————
しゅう動雑音 Slider noise		47mV max. JIS-C6443による According to JIS-C6443				20mV max. JIS-C6443による According to JIS-C6443
絶縁抵抗 Insulation resistance		DC 500Vにて100MΩ以上 100MΩ min. at 500V DC				
耐電圧 Voltage proof		AC 500Vにて1分間 500V AC for 1minute				

注記  
Notes

※1 本規格の場合はDC専用品となりますので、事前にご指定ください。

※2 RK168はAC専用品となります。

※1 Note that this specification applies to DC products only.

※2 RK168 is AC only.

## 耐久性能 Durability

回転寿命 Rotational life	15,000 cycles
-------------------------	---------------

# 16形、18形、27形、40形、50形金属軸ボリューム共通仕様

## Common Specifications for 16mm Size, 18mm Size, 27mm Size, 40mm Size, 50mm Size Metal shaft Potentiometers

### 機械的性能 Mechanical characteristics

項目 Items	タイプ Type	RK16 (16mm size)		RK18 (18mm size)		RK27 (27mm size)		RK40 (40mm size)	RK50 (50mm size)																																
		1軸 Single-shaft	2軸 Dual-shaft	1軸 Single-shaft	2軸 Dual-shaft	1軸 Single-shaft		1軸 Single-shaft	1軸 Single-shaft																																
全回転角度 Total rotational angle		300±3°	300±5°	300±3°		300±3°		300±3°	300±3°																																
回転トルク Rotation torque		3 to 25mN・m {30 to 250gf・cm}		5 to 35mN・m {50 to 350gf・cm}		6 to 35mN・m {60 to 350gf・cm}		10 to 40mN・m {100 to 400gf・cm}	28 ± 15mN・m {280 ± 150gf・cm}																																
クリック トルク Detent torque	Center detent	回転トルク+3~30mN・m {30~300gf・cm}		Rotational torque+3 to 35mN・m {30 to 350gf・cm}		回転トルク+5~30mN・m {50~300gf・cm}		Rotational torque+5 to 30mN・m {50 to 300gf・cm}																																	
	11 detent		—	5 to 35 mN・m {50 to 350gf・cm}				40±20 mN・m {400±200gf・cm}	—																																
	21 detent	10 to 50 mN・m 100 to 500 gf・cm	—			25±15 mN・m {250±150gf・cm}		—	—																																
	31 detent		—					30±20 mN・m {300±200gf・cm}	—																																
41 detent		—			8 to 35 mN・m {80 to 350gf・cm}		—	—																																	
軸の回転止め強度 Shaft stopper strength		0.9N・m {9kgf・cm}	0.6N・m {6kgf・cm}	0.9N・m {9kgf・cm}		0.9N・m {9kgf・cm}		1.2N・m {12kgf・cm}	1.5N・m {15kgf・cm}																																
軸の押し引き強度 Push-pull strength		100N max. {10kgf} max.							150N max. {15kgf} max.																																
軸ガタ Shaft wobble		軸受取り付け後、先端から5mmの位置にLoad A N {gf}の荷重を加えた時の、先端から5mmの位置での軸がたはBmm P-P以下のこと。 The shaft wobble at the position of 5mm from the tip when a Load A N {gf} is applied to said position after mounting the bushing shall be B mm P-P max.																																							
		<table border="1"> <thead> <tr> <th>Shaft length mm</th> <th>15</th> <th>20</th> <th>25</th> <th>30</th> <th>35</th> <th>40</th> <th>45</th> </tr> </thead> <tbody> <tr> <td>Load A N {gf}</td> <td>10 {1000}</td> <td>6.7 {670}</td> <td>5 {500}</td> <td>4 {400}</td> <td>3.4 {340}</td> <td>2.9 {290}</td> <td>2.5 {250}</td> </tr> <tr> <td>Single and outer shafts B mm P-P</td> <td>0.14</td> <td>0.2</td> <td>0.27</td> <td>0.34</td> <td>0.4</td> <td>0.47</td> <td>0.54</td> </tr> <tr> <td>Inner-shaft B mm P-P</td> <td>—</td> <td>—</td> <td>0.4</td> <td>0.5</td> <td>0.6</td> <td>0.7</td> <td>0.8</td> </tr> </tbody> </table>							Shaft length mm	15	20	25	30	35	40	45	Load A N {gf}	10 {1000}	6.7 {670}	5 {500}	4 {400}	3.4 {340}	2.9 {290}	2.5 {250}	Single and outer shafts B mm P-P	0.14	0.2	0.27	0.34	0.4	0.47	0.54	Inner-shaft B mm P-P	—	—	0.4	0.5	0.6	0.7	0.8	P.81 参照 Refer to page 81.
Shaft length mm	15	20	25	30	35	40	45																																		
Load A N {gf}	10 {1000}	6.7 {670}	5 {500}	4 {400}	3.4 {340}	2.9 {290}	2.5 {250}																																		
Single and outer shafts B mm P-P	0.14	0.2	0.27	0.34	0.4	0.47	0.54																																		
Inner-shaft B mm P-P	—	—	0.4	0.5	0.6	0.7	0.8																																		
		※ モータ駆動タイプは除く。 ※ Except for the motor drive type.																																							
軸受ねじ 締付け強度 Bushing-nut tightening strength		12N・m {12kgf・cm} max.	15N・m {15kgf・cm} max.																																						
		M7	M9			M8, M9																																			
クリック角度 Detent angle		<table border="1"> <thead> <tr> <th>クリック数 No. of detents</th> <th>センタクリック Center- detent</th> <th>11点クリック 11 detents</th> <th>21点クリック 21 detents</th> <th>31点クリック 31 detents</th> <th>41点クリック 41 detents</th> </tr> </thead> <tbody> <tr> <td>角度 Angle</td> <td>150±3°</td> <td>※ 30±30°</td> <td>※ 15±2°</td> <td>※ 10±2°</td> <td>※ 7.5±2°</td> </tr> </tbody> </table>							クリック数 No. of detents	センタクリック Center- detent	11点クリック 11 detents	21点クリック 21 detents	31点クリック 31 detents	41点クリック 41 detents	角度 Angle	150±3°	※ 30±30°	※ 15±2°	※ 10±2°	※ 7.5±2°	—																				
クリック数 No. of detents	センタクリック Center- detent	11点クリック 11 detents	21点クリック 21 detents	31点クリック 31 detents	41点クリック 41 detents																																				
角度 Angle	150±3°	※ 30±30°	※ 15±2°	※ 10±2°	※ 7.5±2°																																				
		※ 両端未±3°とする。 ※ Both ends ±3°																																							

# Measurement and Test Methods

**〔抵抗変化特性〕**

軸(レバー)を規定の位置に置き、規定の端子間(端子1と2との間または端子2と3との間)の電圧を測定し、端子1と3との間の電圧に対する百分率を算出する。

参考：回転角度(移動量)に対する抵抗変化の基準は、次のとおりである。

**〔Resistance taper〕**

With the shaft (lever) placed in the specified position, shall be determined by measuring the voltage between the specified terminals (between terminals 1 and 2 or between terminals 2 and 3) and calculating the percentage in reference to the voltage between terminals 1 and 3.

Reference: Standard resistance tapers in reference to rotational angles (travels) are as shown below.

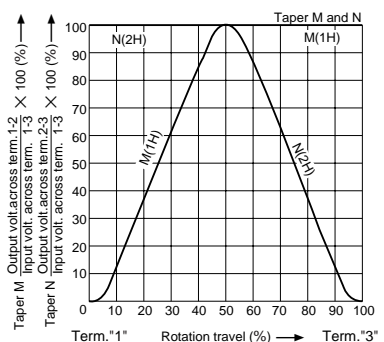
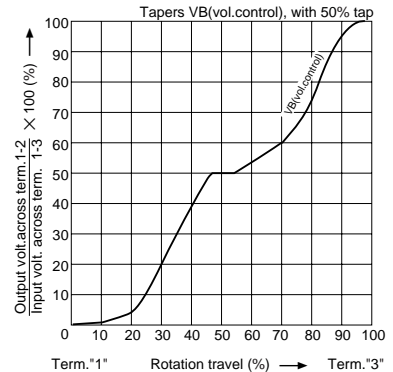
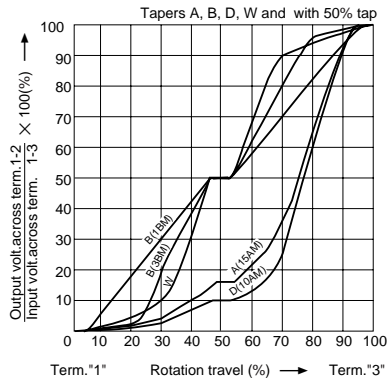
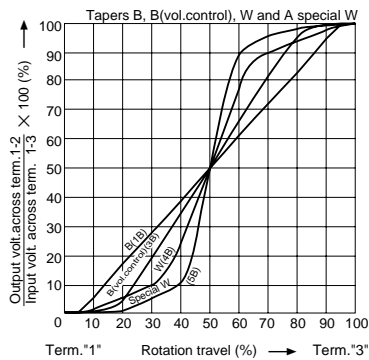
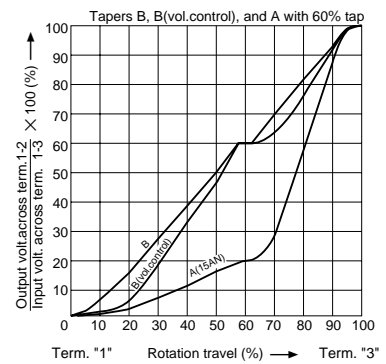
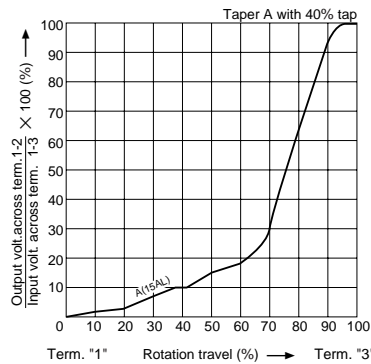
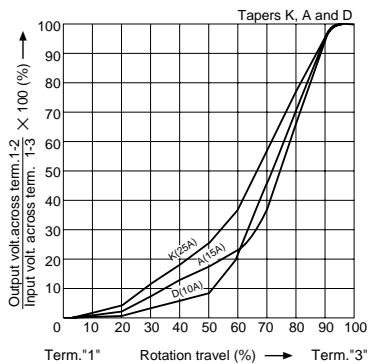

NOTE : Resistance characteristic of curve N is plotted with respect to terminal "3"

