

1.0 GENERAL DESCRIPTION:
 UV-J IS A ROTARY POSITION SENSOR DESIGNED FOR COST EFFECTIVE FEEDBACK SENSING ELEMENT FOR SERVO SYSTEM WHERE HIGH PERFORMANCE AND RELIABILITY ARE REQUIRED IN SEVERE OPERATING ENVIRONMENTS.

2.0 ENVIRONMENTAL SPECIFICATIONS:
 2.1 OPERATING TEMPERATURE: -40°C TO +125°C
 2.2 STORAGE TEMPERATURE: -40°C TO +125°C
 2.3 SHOCK: 50 G's, 11 mS.
 2.4 VIBRATION: 20 G's, 10 to 2,000 Hz.

3.0 ELECTRICAL SPECIFICATIONS: (UNLESS OTHERWISE SPECIFIED, Ta=25°C)
 3.1 INPUT VOLTAGE (Vin): 10 Vdc MAX. Ta = -40°C TO +125°C
 3.2 INPUT IMPEDANCE: 15 KOHMS ±30
 3.3 ELECTRICAL ANGLE: [Ⓐ] ±40° (F.S.=90°) Ta = -40°C TO +125°C
 3.4 INDEPENDENT LINEARITY: ±1.5% F.S. Ta = -40°C TO +125°C
 3.5 OUTPUT SENSITIVITY: 2.5%Vin/10° MIN.
 3.6 INSULATION RESISTANCE: 100 Meg OHMS MIN. @ 500 Vdc.
 3.7 DIELECTRIC STRENGTH: 500 Vrms @ 50/60 Hz.
 3.8 TEMPERATURE EFFECT (DEVIATION IS EXPRESSED IN EQUIVALENT ANGLE): REFER TO FIGURE 4 FOR CLARIFICATION.

3.8.1 FOR MODEL UV-J (STANDARD UNIT W/O TEMP. COMPENSATION CIRCUIT)

Ta = 0°C to +75°C

AT 0° POSITION: 1.5° MAX.
 AT ±40° POSITION: 6.7° MAX.

3.8.2 FOR MODEL UV-J-1-TCx (UNIT WITH TEMP. COMPENSATION CIRCUIT)

	-TCA (0°C to +60°C)	-TCB (-20°C to +80°C)	-TCC (-30°C to +100°C)
AT 0° POSITION:	0.3° MAX.	0.5° MAX.	0.7° MAX.
[Ⓑ] AT ±40° POSITION:	3.1° MAX.	4.9° MAX.	6.7° MAX.

4.0 MECHANICAL SPECIFICATIONS:
 4.1 MECHANICAL ANGLE: 90°
 4.2 TORQUE: 20 g-cm MAX. [Ⓐ]
 4.3 WEIGHT: 20 g MAX.

5.0 ELECTRICAL CONNECTIONS: REFER TO FIGURES 1 AND 2.

6.0 MARKING:
 EACH UNIT SHALL BE MARKED WITH MIDORI MODEL NO. AND MANUFACTURING LOT NO. (OR DATE CODE) OR SERIAL NO.

7.0 MATERIAL:
 7.1 HOUSING and ROTOR: POLYPHENYLENE SULFIDED, GLASS ENFORCED.
 7.2 MOUNTING HOLE INSERT: NICKEL PLATED
 7.3 INSULATED WIRE: [Ⓑ]AVX-0.5f (NO.18AWG, 20 STRANDED, CONDUCTORS, VINYL SLEEVE)

UNLESS OTHERWISE SPECIFIED, DIMENSIONS ARE IN mm(in).
 TOLERANCES:
 ANGLES ±1.5°
 <10 mm: ±0.25
 <100 mm: ±0.5
 >100 mm: ±1

REVISION				
C.O.N	SYM	DESCRIPTION	DATE	DRAWN
A		ELECT. ANGLE WAS P45D. TORQUE WAS 10 g-cm MAX.	3/30/92	T.TSUGAWA
B		PARA.3.8.1, FIGURES 3 AND 4; CORRECTED FOR 90D F.S. FIG.1.0: "150±20" WAS "200P15". FIG.1.1: 1.75 WAS 1.5.	10/12/92	T.TSUGAWA

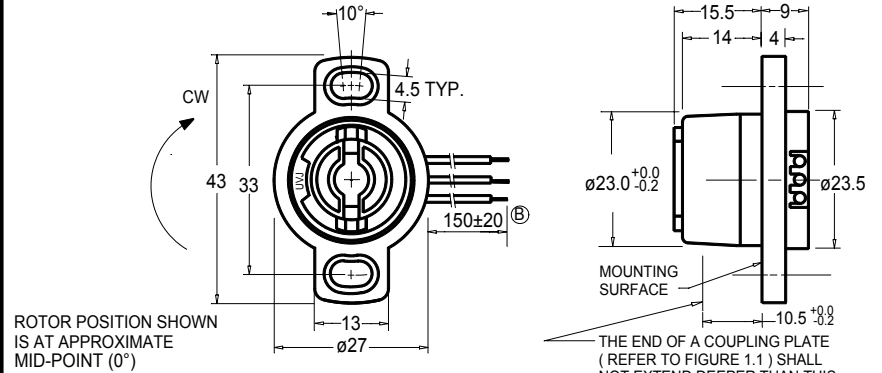

FIGURE 1 OUTLINE DIMENSIONS

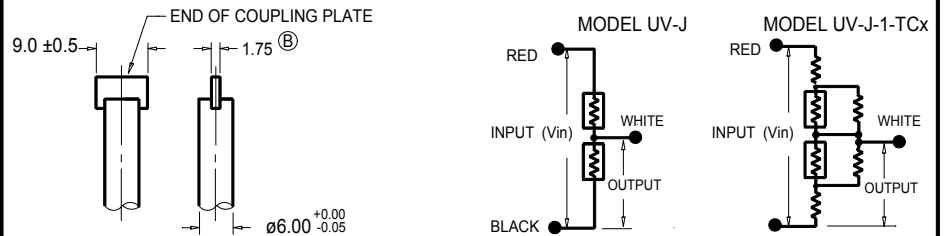
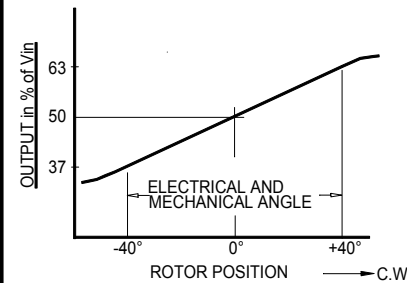
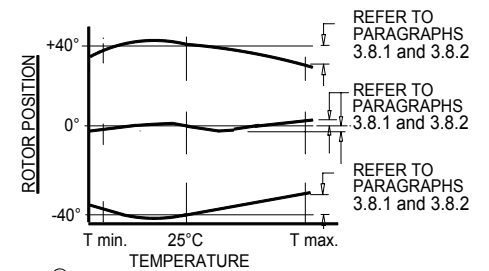

FIGURE 1.1 RECOMMENDED COUPLING SHAFT

FIGURE 2 SCHEMATIC



[Ⓑ] FIGURE 3 TYPICAL OUTPUT CHARACTERISTICS



[Ⓑ] FIGURE 4 TYPICAL TEMPERATURE CHARACTERISTICS (REF. ONLY)

DRAWN T. TSUGAWA CHECKED Y. NAKAMURA APPROVED APPROVED	DATE 2/14/92 DATE 2/28/92 DATE DATE	SPECIFICATION DWG FOR MODEL UV-J CONTACTLESS ROTARY POSITION SENSOR	Midori America Corporation FULLERTON, CA	
SCALE:	FILE: UV-J		A-MAC-B19	B