

SN65LBC179A, SN75LBC179A LOW-POWER DIFFERENTIAL LINE DRIVER AND RECEIVER PAIRS

SLLS377C – MAY 2000 – REVISED JUNE 2001

- High-Speed Low-Power LinBiCMOS™ Circuitry Designed for Signaling Rates† of up to 30 Mbps
- Bus-Pin ESD Protection Exceeds 12 kV HBM
- Very Low Disabled Supply-Current Requirements . . . 700 μ A Max
- Common-Mode Voltage Range of -7 V to 12 V
- Low Supply Current . . . 15 mA Max
- Compatible With ANSI Standard TIA/EIA-485-A and ISO8482: 1987(E)
- Positive and Negative Output Current Limiting
- Driver Thermal Shutdown Protection

description

The SN65LBC179A and SN75LBC179A differential driver and receiver pairs are monolithic integrated circuits designed for bidirectional data communication over long cables that take on the characteristics of transmission lines. They are balanced, or differential, voltage mode devices that are compatible with ANSI standard TIA/EIA-485-A and ISO 8482:1987(E). The A version offers improved switching performance over its predecessors without sacrificing significantly more power.

The SN65LBC179A and SN75LBC179A combine a differential line driver and differential input line receiver and operate from a single 5-V supply. The driver differential outputs and the receiver differential inputs are connected to separate terminals for full-duplex operation and are designed to present minimum loading to the bus when powered off ($V_{CC} = 0$). These parts feature a wide positive and negative common-mode voltage range making them suitable for point-to-point or multipoint data bus applications. The devices also provide positive- and negative-current limiting and thermal shutdown for protection from line fault conditions.

The SN65LBC179A is characterized over the industrial temperature range of -40°C to 85°C . The SN75LBC179A is characterized for operation over the commercial temperature range of 0°C to 70°C .

SN65LBC179AD (Marked as BL179A)
SN65LBC179AP (Marked as 65LBC179A)
SN75LBC179AD (Marked as LB179A)
SN75LBC179AP (Marked as 75LBC179A)
(TOP VIEW)

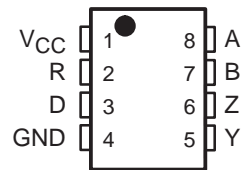

logic diagram (positive logic)

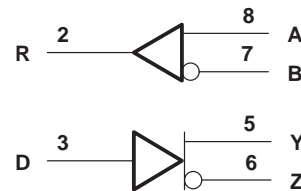

Function Tables

DRIVER

INPUT D	OUTPUTS	
	Y	Z
H	H	L
L	L	H
Open	H	L

RECEIVER

DIFFERENTIAL INPUTS A-B	OUTPUT R
$V_{ID} \geq 0.2$ V	H
-0.2 V $< V_{ID} < 0.2$ V	?
$V_{ID} \leq -0.2$ V	L
Open circuit	H

H = high level, L = low level,
? = indeterminate



Please be aware that an important notice concerning availability, standard warranty, and use in critical applications of Texas Instruments semiconductor products and disclaimers thereto appears at the end of this data sheet.

† Signaling rate by TIA/EIA-485-A definition restrict transition times to 30% of the bit length, and much higher signaling rates may be achieved without this requirement as displayed in the *TYPICAL CHARACTERISTICS* of this device.

LinBiCMOS is a trademark of Texas Instruments.

PRODUCTION DATA information is current as of publication date. Products conform to specifications per the terms of Texas Instruments standard warranty. Production processing does not necessarily include testing of all parameters.



POST OFFICE BOX 655303 • DALLAS, TEXAS 75265

Copyright © 2001, Texas Instruments Incorporated

SN65LBC179A, SN75LBC179A LOW-POWER DIFFERENTIAL LINE DRIVER AND RECEIVER PAIRS

SLLS377C – MAY 2000 – REVISED JUNE 2001

AVAILABLE OPTIONS

T _A	PACKAGE	
	SMALL OUTLINE (D)	PLASTIC DUAL-IN-LINE
0°C to 70°C	SN75LBC179AD	SN75LBC179AP
-40°C to 85°C	SN65LBC179AD	SN65LBC179AP

schematics of inputs and outputs

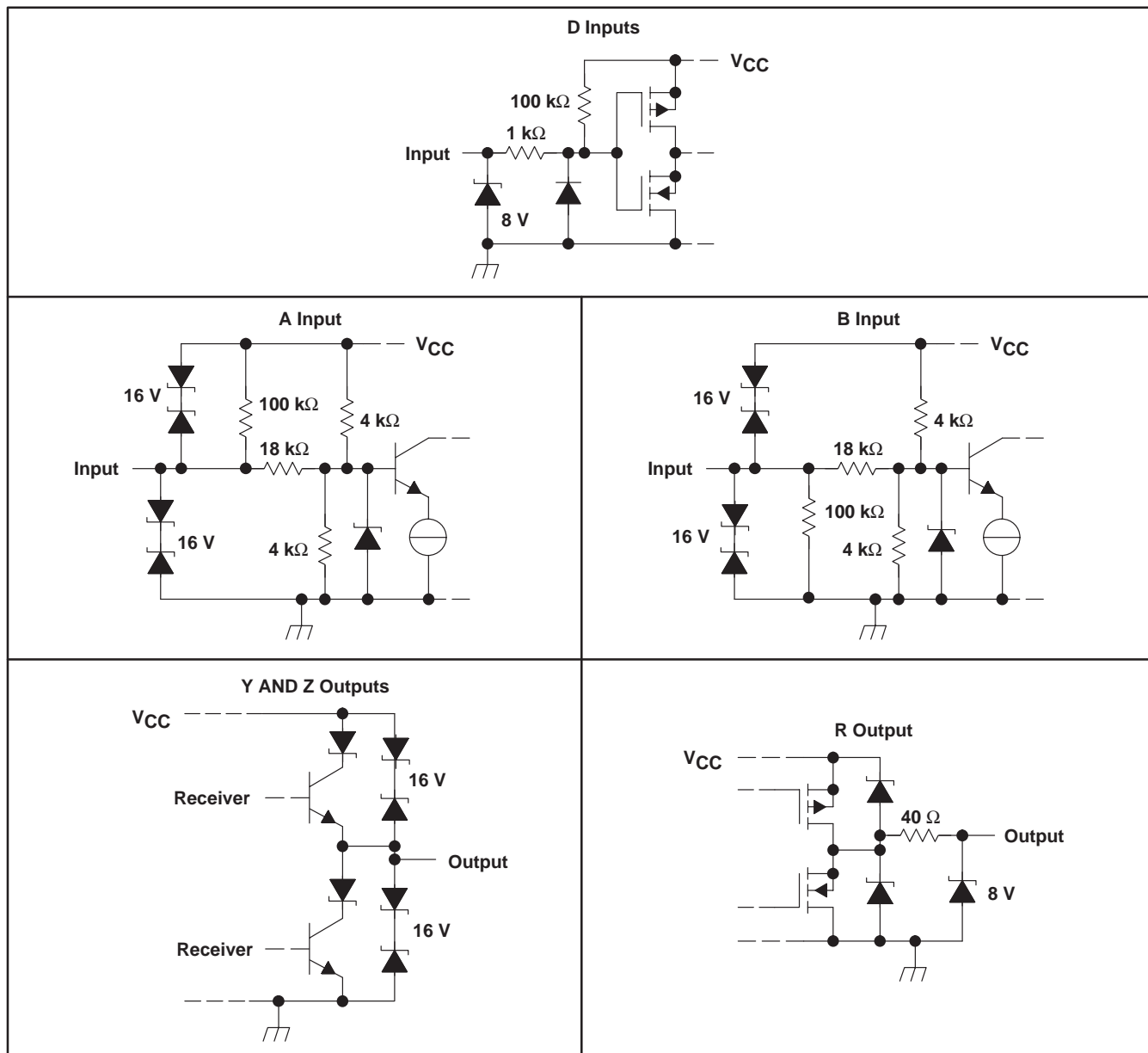

SN65LBC179A, SN75LBC179A

LOW-POWER DIFFERENTIAL LINE DRIVER AND RECEIVER PAIRS

SLLS377C – MAY 2000 – REVISED JUNE 2001

absolute maximum ratings†

Supply voltage range, V_{CC} (see Note 1)	–0.3 V to 6 V
Voltage range at A, B, Y, or Z (see Note 1)	–10 V to 15 V
Voltage range at D or R (see Note 1)	–0.3 V to $V_{CC} + 0.5$ V
Electrostatic discharge: Bus terminals and GND, Class 3, A: (see Note 2)	12 kV
Bus terminals and GND, Class 3, B: (see Note 2)	400 V
All terminals, Class 3, A:	3 kV
All terminals, Class 3, B:	400 V
Continuous total power dissipation (see Note 3)	Internally limited
Total power dissipation	See Dissipation Rating Table
Storage temperature range, T_{stg}	–65°C to 150°C
Lead temperature 1,6 mm (1/16 inch) from case for 10 seconds	260°C

† Stresses beyond those listed under “absolute maximum ratings” may cause permanent damage to the device. These are stress ratings only, and functional operation of the device at these or any other conditions beyond those indicated under “recommended operating conditions” is not implied. Exposure to absolute-maximum-rated conditions for extended periods may affect device reliability.

- NOTES:
1. All voltage values, except differential I/O bus voltages, are with respect to GND.
 2. Tested in accordance with MIL–STD–883C, Method 3015.7
 3. The maximum operating junction temperature is internally limited. Uses the dissipation rating table to operate below this temperature.

DISSIPATION RATING TABLE

PACKAGE	$T_A \leq 25^\circ\text{C}$	DERATING FACTOR‡	$T_A = 70^\circ\text{C}$	$T_A = 85^\circ\text{C}$
	POWER RATING	ABOVE $T_A = 25^\circ\text{C}$	POWER RATING	POWER RATING
D	725 mW	5.8 mW/°C	464 mW	377 mW
P	1100 mW	8.08 mW/°C	640 mW	520 mW

‡ This is the inverse of the junction-to-ambient thermal resistance when board-mounted and with no air flow.

recommended operating conditions

		MIN	NOM	MAX	UNIT
Supply voltage, V_{CC}		4.75	5	5.25	V
High-level input voltage, V_{IH}	D	2		V_{CC}	V
Low-level input voltage, V_{IL}	D	0		0.8	V
Differential input voltage, V_{ID} (see Note 4)		–12§		12	V
Voltage at any bus terminal (separately or common-mode), V_O , V_I , or V_{IC}	A, B, Y, or Z	–7		12	V
High-level output current, I_{OH}	Y or Z	–60			mA
	R	–8			
Low-level output current, I_{OL}	Y or Z			60	mA
	R			8	
Operating free-air temperature, T_A	SN65LBC179A	–40		85	°C
	SN75LBC179A	0		70	

§ The algebraic convention, in which the least positive (most negative) limit is designated as minimum, is used in this data sheet.

NOTE 4: Differential input/output bus voltage is measured at the noninverting terminal with respect to the inverting terminal.



SN65LBC179A, SN75LBC179A

LOW-POWER DIFFERENTIAL LINE DRIVER AND RECEIVER PAIRS

SLLS377C – MAY 2000 – REVISED JUNE 2001

driver electrical characteristics over recommended operating conditions (unless otherwise noted)

PARAMETER		TEST CONDITIONS		MIN	TYP†	MAX	UNIT	
V _{IK}	Input clamp voltage	I _I = -18 mA		-1.5	-0.8		V	
V _{OD}	Differential output voltage	R _L = 54 Ω, See Figure 1	SN65LBC179A	1	1.5	3	V	
			SN75LBC179A	1.1	1.5	3		
		R _L = 60 Ω, -7 < V _(tot) < 12, See Figure 2	SN65LBC179A	1	1.5	3		
			SN75LBC179A	1.1	1.5	3		
Δ V _{OD}	Change in magnitude of differential output voltage (see Note 5)		See Figures 1 and 2		-0.2	0.2	V	
V _{OC(SS)}	Steady-state common-mode output voltage		See Figure 1		1.8	2.4	2.8	V
ΔV _{OC(SS)}	Change in steady-state common-mode output voltage (see Note 5)		See Figure 1		-0.1	0.1	V	
I _O	Output current with power off	V _{CC} = 0,	V _O = -7 V to 12 V	-10	±1	10	μA	
I _{IH}	High-level input current	V _I = 2. V		-100			μA	
I _{IL}	Low-level input current	V _I = 0.8 V		-100			μA	
I _{OS}	Short-circuit output current	-7 V ≤ V _O ≤ 12 V		-250	±70	250	mA	
I _{CC}	Supply current	No load, V _I = 0 or V _{CC}		8.5		15	mA	

† All typical values are at V_{CC} = 5 V, T_A = 25°C.

NOTE 5: Δ|V_{OD}| and Δ|V_{OC}| are the changes in the steady-state magnitude of V_{OD} and V_{OC}, respectively, that occur when the input is changed from a high level to a low level.

driver switching characteristics over recommended operating conditions (unless otherwise noted)

PARAMETER		TEST CONDITIONS		MIN	TYP	MAX	UNIT
t _{PLH}	Propagation delay time, low-to-high-level output	R _L = 54 Ω, See Figure 3	C _L = 50 pF,	2	6	12	ns
t _{PHL}	Propagation delay time, high-to-low-level output			2	6	12	ns
t _{sk(p)}	Pulse skew (t _{PHL} - t _{PLH})				0.3	1	ns
t _r	Differential output signal rise time			4	7.5	11	ns
t _f	Differential output signal fall time			4	7.5	11	ns



SN65LBC179A, SN75LBC179A

LOW-POWER DIFFERENTIAL LINE DRIVER AND RECEIVER PAIRS

SLLS377C – MAY 2000 – REVISED JUNE 2001

RECEIVER SECTION

receiver electrical characteristics over recommended operating conditions (unless otherwise noted)

PARAMETER		TEST CONDITIONS	MIN	TYP	MAX	UNIT	
V_{IT+}	Positive-going input threshold voltage	$I_O = -8 \text{ mA}$			0.2	V	
V_{IT-}	Negative-going input threshold voltage		-0.2				
V_{hys}	Hysteresis voltage ($V_{IT+} - V_{IT-}$)	$I_O = 8 \text{ mA}$		50		mV	
V_{OH}	High-level output voltage	$V_{ID} = 200 \text{ mV}$, $I_{OH} = -8 \text{ mA}$, See Figure 1	4	4.9		V	
V_{OL}	Low-level output voltage	$V_{ID} = -200 \text{ mV}$, $I_{OL} = 8 \text{ mA}$, See Figure 1		0.1	0.8	V	
I_I	Bus input current	$V_{IH} = 12 \text{ V}$, $V_{CC} = 5 \text{ V}$	Other input at 0 V		0.4	1	mA
		$V_{IH} = 12 \text{ V}$, $V_{CC} = 0$			0.5	1	
		$V_{IH} = -7 \text{ V}$, $V_{CC} = 5 \text{ V}$		-0.8	-0.4		
		$V_{IH} = -7 \text{ V}$, $V_{CC} = 0$		-0.8	-0.3		

receiver switching characteristics over recommended operating conditions (unless otherwise noted)

PARAMETER		TEST CONDITIONS	MIN	TYP	MAX	UNIT
t_{PLH}	Propagation delay time, low-to-high-level output	$V_{ID} = -1.5 \text{ V to } 1.5 \text{ V}$, See Figure 4	7	13	20	ns
t_{PHL}	Propagation delay time, high-to-low-level output		7	13	20	ns
$t_{sk(p)}$	Pulse skew ($ t_{PLH} - t_{PHL} $)			0.5	1.5	ns
t_r	Rise time, output	See Figure 4		2.1	3.3	ns
t_f	Fall time, output			2.1	3.3	ns

PARAMETER MEASUREMENT INFORMATION

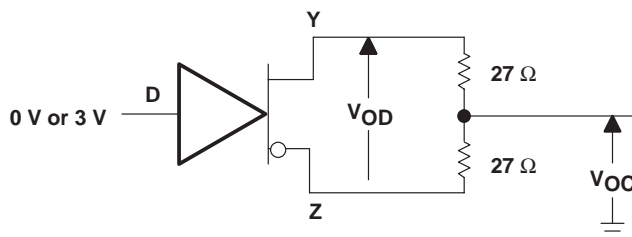

Figure 1. Driver V_{OD} and V_{OC}

SN65LBC179A, SN75LBC179A LOW-POWER DIFFERENTIAL LINE DRIVER AND RECEIVER PAIRS

SLLS377C – MAY 2000 – REVISED JUNE 2001

PARAMETER MEASUREMENT INFORMATION

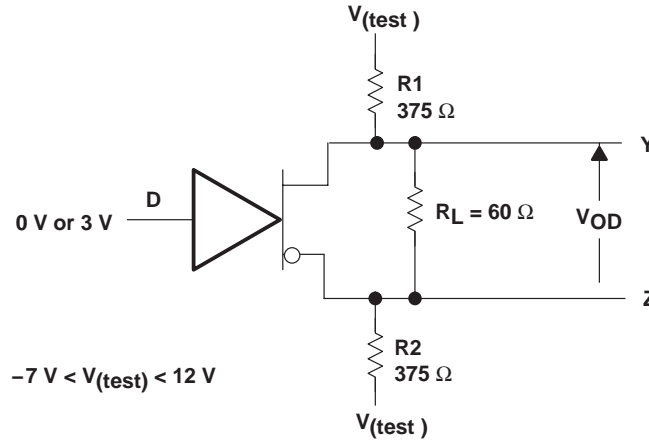
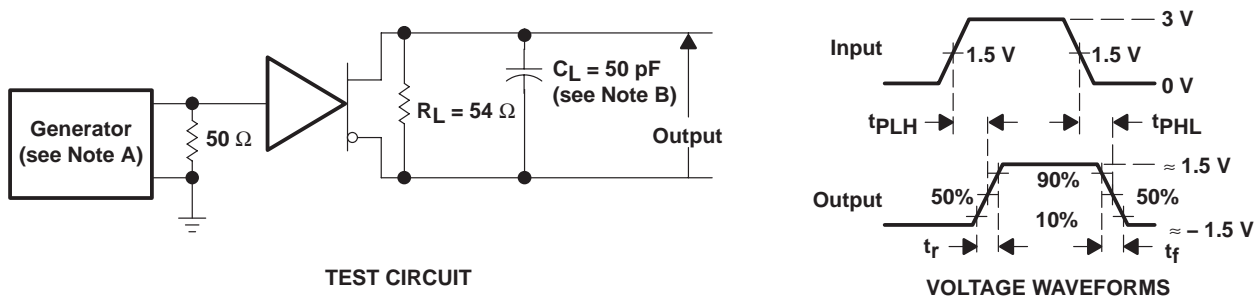
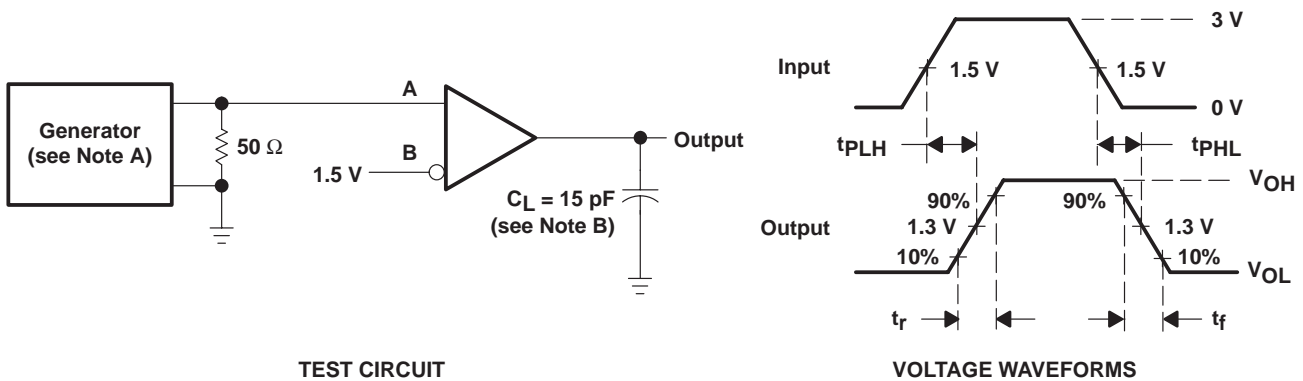

Figure 2. Driver V_{OD} With Common-Mode Loading



NOTES: A. The input pulse is supplied by a generator having the following characteristics: $PRR \leq 1$ MHz, 50% duty cycle, $t_r \leq 6$ ns, $t_f \leq 6$ ns, $Z_O = 50 \Omega$.
B. C_L includes probe and jig capacitance.

Figure 3. Driver Test Circuits and Voltage Waveforms



NOTES: A. The input pulse is supplied by a generator having the following characteristics: $PRR \leq 1$ MHz, 50% duty cycle, $t_r \leq 6$ ns, $t_f \leq 6$ ns, $Z_O = 50 \Omega$.
B. C_L includes probe and jig capacitance.

Figure 4. Receiver Test Circuit and Voltage Waveforms

TYPICAL CHARACTERISTICS

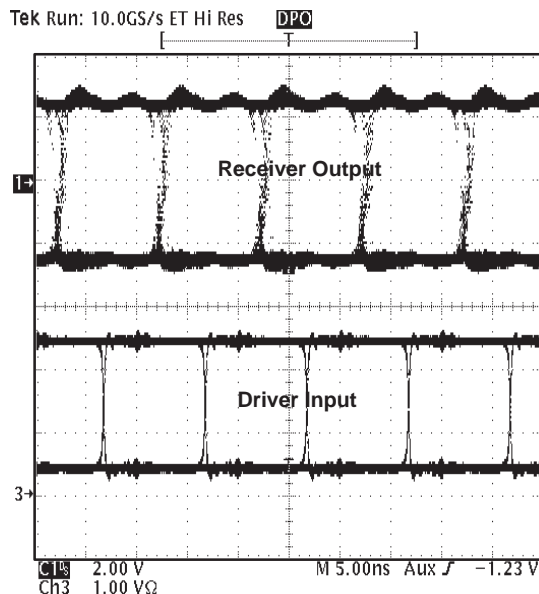

Figure 5. Typical Waveform of Non-Return-To-Zero (NRZ), Pseudorandom Binary Sequence (PRBS) Data at 100 Mbps Through 15m, of CAT 5 Unshielded Twisted Pair (UTP) Cable

TIA/EIA-485-A defines a maximum signaling rate as that in which the transition time of the voltage transition of a logic-state change remains less than or equal to 30% of the bit length. Transition times of greater length perform quite well even though they do not meet the standard by definition.

SN65LBC179A, SN75LBC179A LOW-POWER DIFFERENTIAL LINE DRIVER AND RECEIVER PAIRS

SLLS377C – MAY 2000 – REVISED JUNE 2001

TYPICAL CHARACTERISTICS

**AVERAGE SUPPLY CURRENT
vs
FREQUENCY**

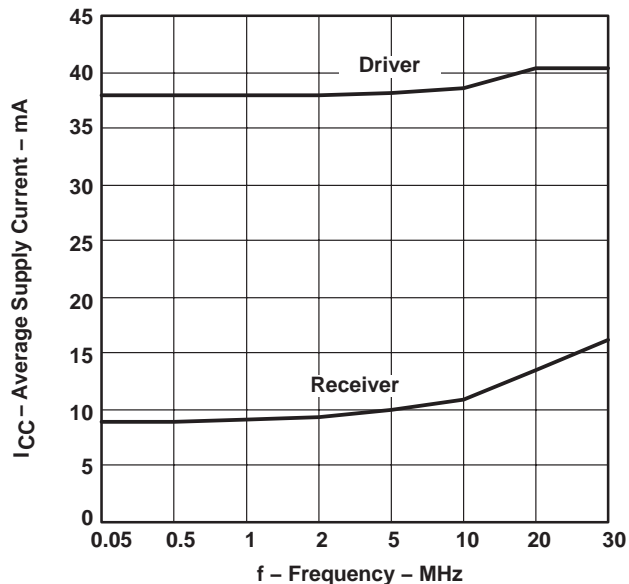

Figure 6

**LOGIC INPUT CURRENT
vs
INPUT VOLTAGE**

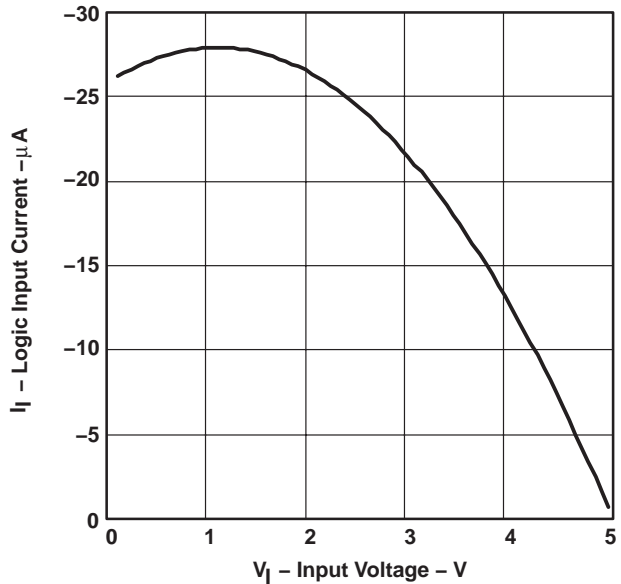

Figure 7

**INPUT CURRENT
vs
INPUT VOLTAGE**

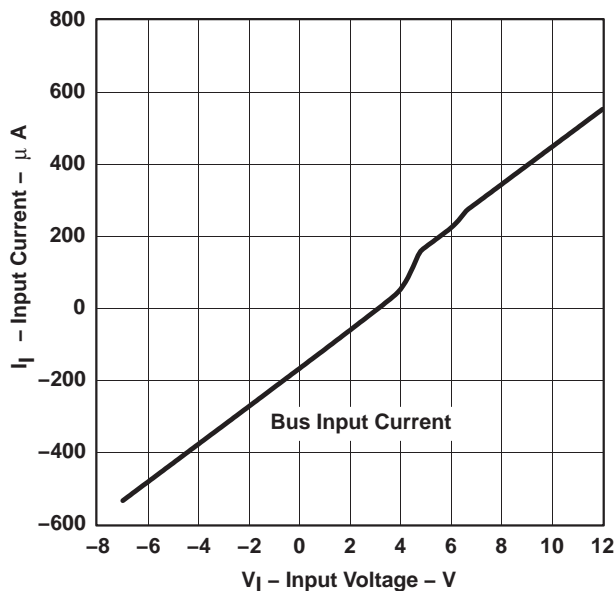

Figure 8

**LOW-LEVEL OUTPUT VOLTAGE
vs
LOW-LEVEL OUTPUT CURRENT**

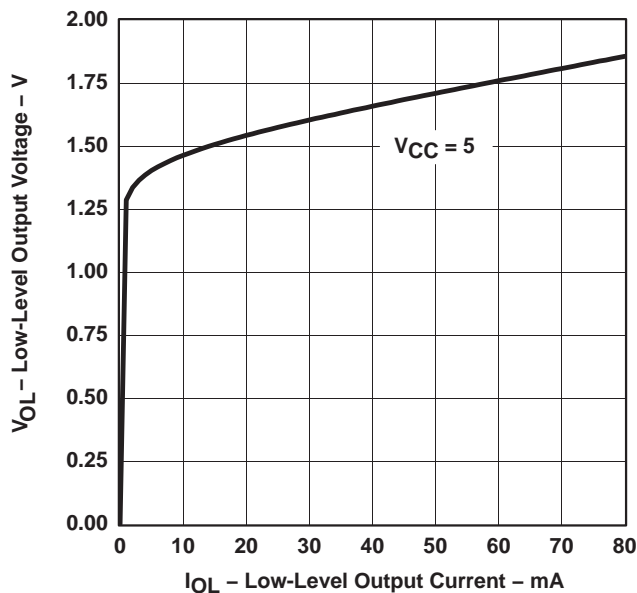

Figure 9



TYPICAL CHARACTERISTICS

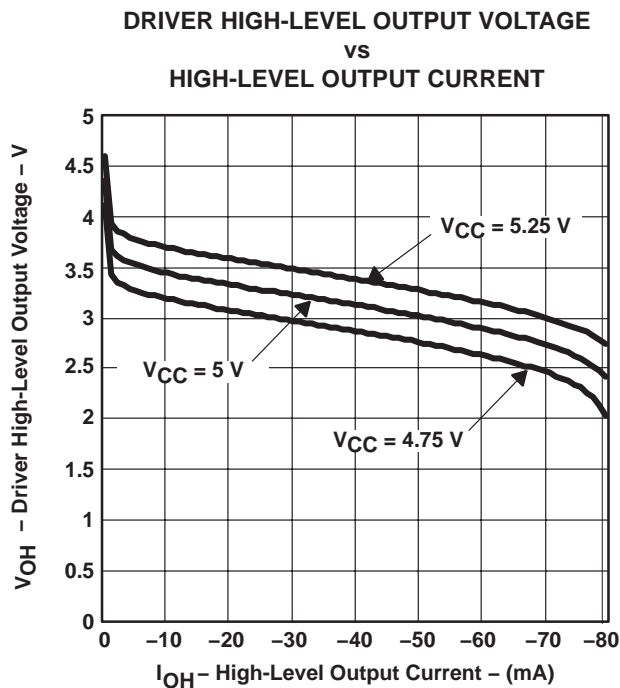

Figure 10

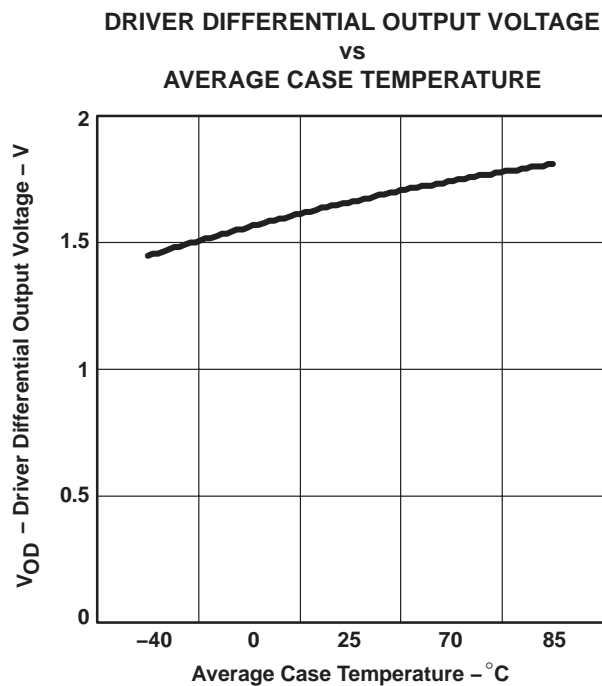

Figure 11

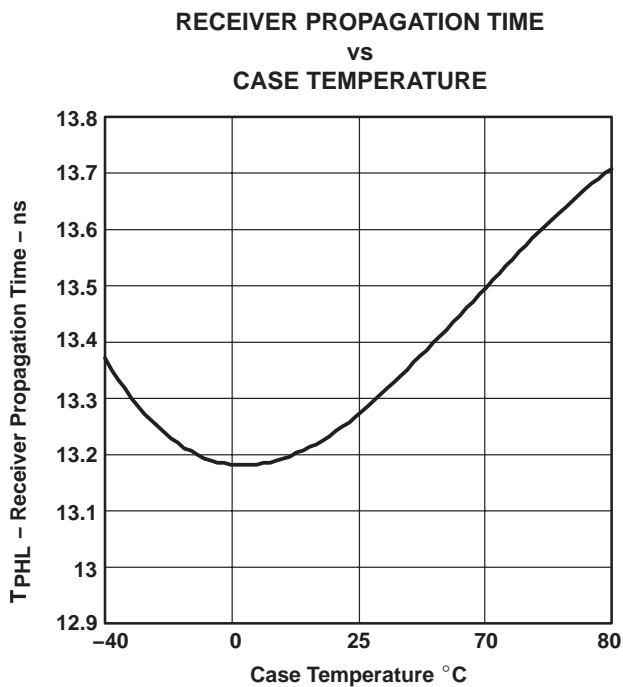

Figure 12

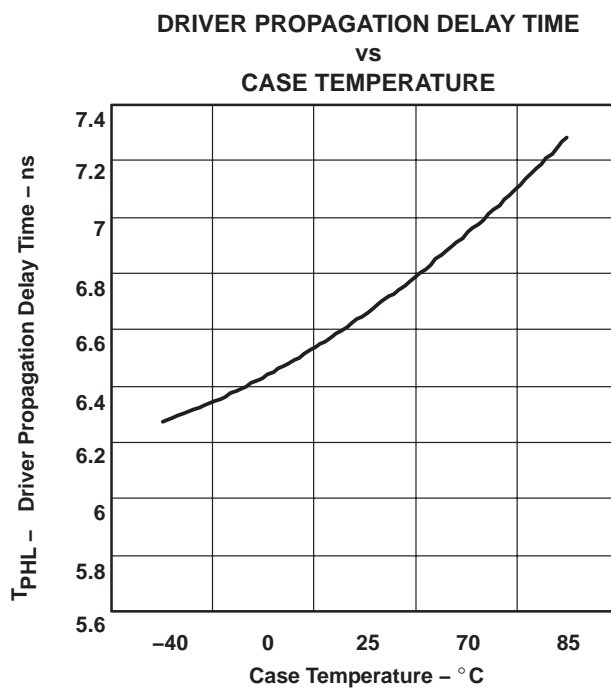

Figure 13

SN65LBC179A, SN75LBC179A LOW-POWER DIFFERENTIAL LINE DRIVER AND RECEIVER PAIRS

SLLS377C – MAY 2000 – REVISED JUNE 2001

TYPICAL CHARACTERISTICS

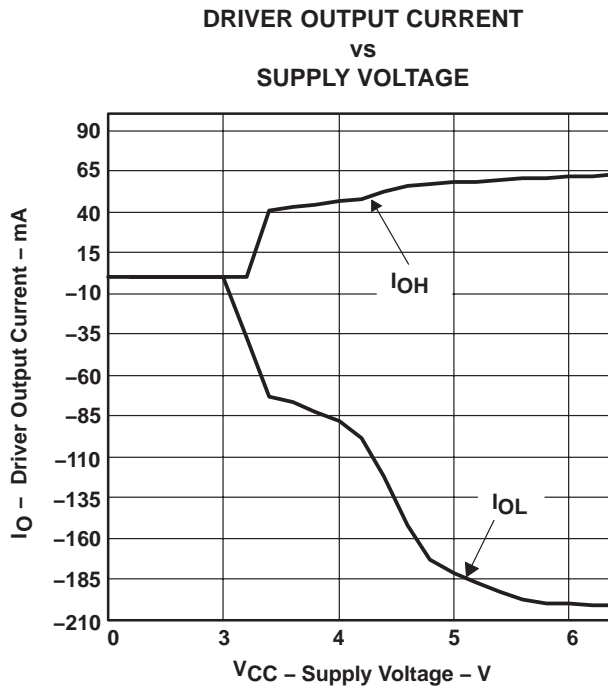

Figure 14

SN65LBC179A, SN75LBC179A LOW-POWER DIFFERENTIAL LINE DRIVER AND RECEIVER PAIRS

SLLS377C – MAY 2000 – REVISED JUNE 2001

MECHANICAL INFORMATION

D (R-PDSO-G)**

PLASTIC SMALL-OUTLINE PACKAGE

14 PINS SHOWN

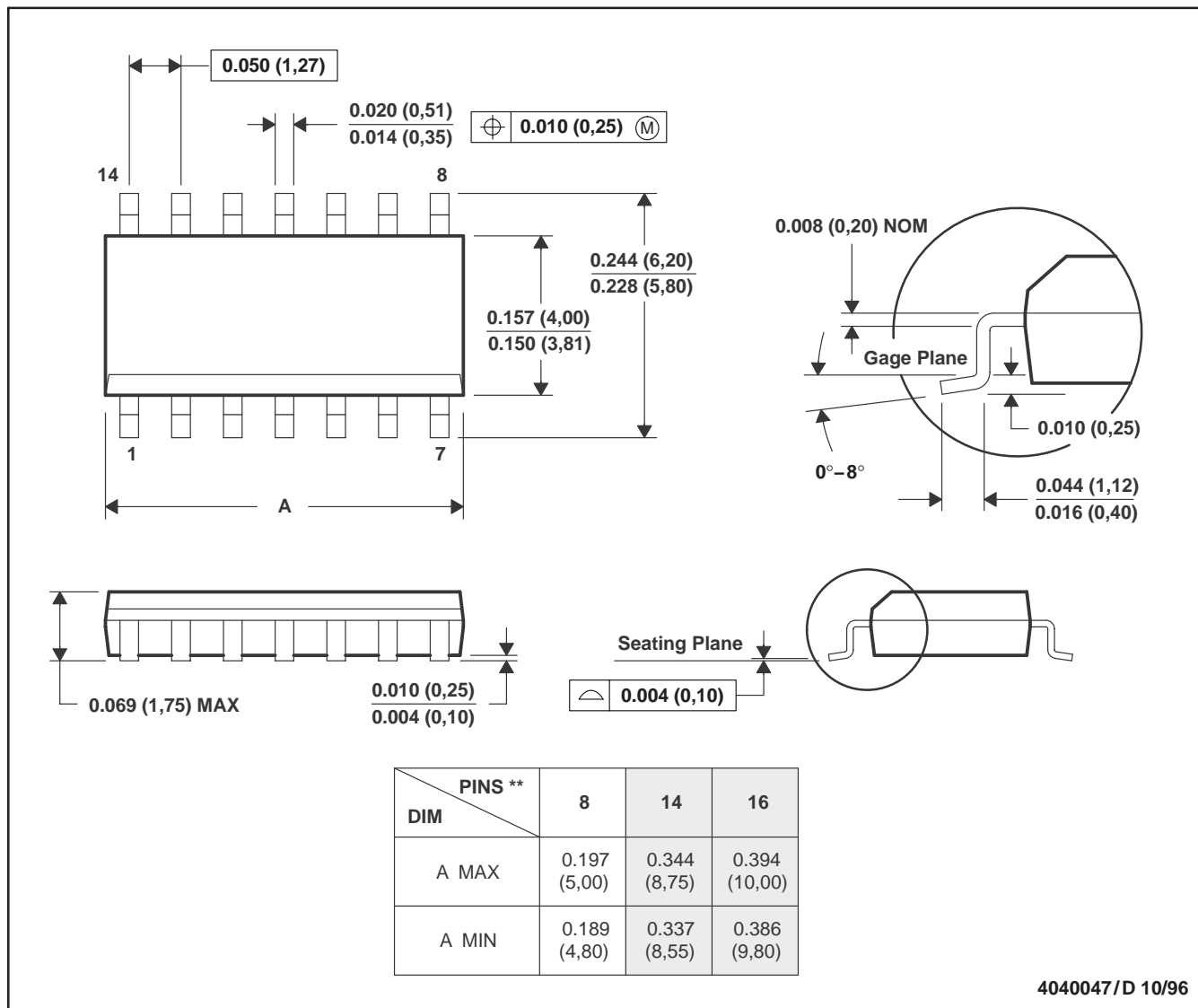

- NOTES: A. All linear dimensions are in inches (millimeters).
 B. This drawing is subject to change without notice.
 C. Body dimensions do not include mold flash or protrusion, not to exceed 0.006 (0,15).
 D. Falls within JEDEC MS-012

SN65LBC179A, SN75LBC179A LOW-POWER DIFFERENTIAL LINE DRIVER AND RECEIVER PAIRS

SLLS377C – MAY 2000 – REVISED JUNE 2001

MECHANICAL INFORMATION

P (R-PDIP-T8)

PLASTIC DUAL-IN-LINE

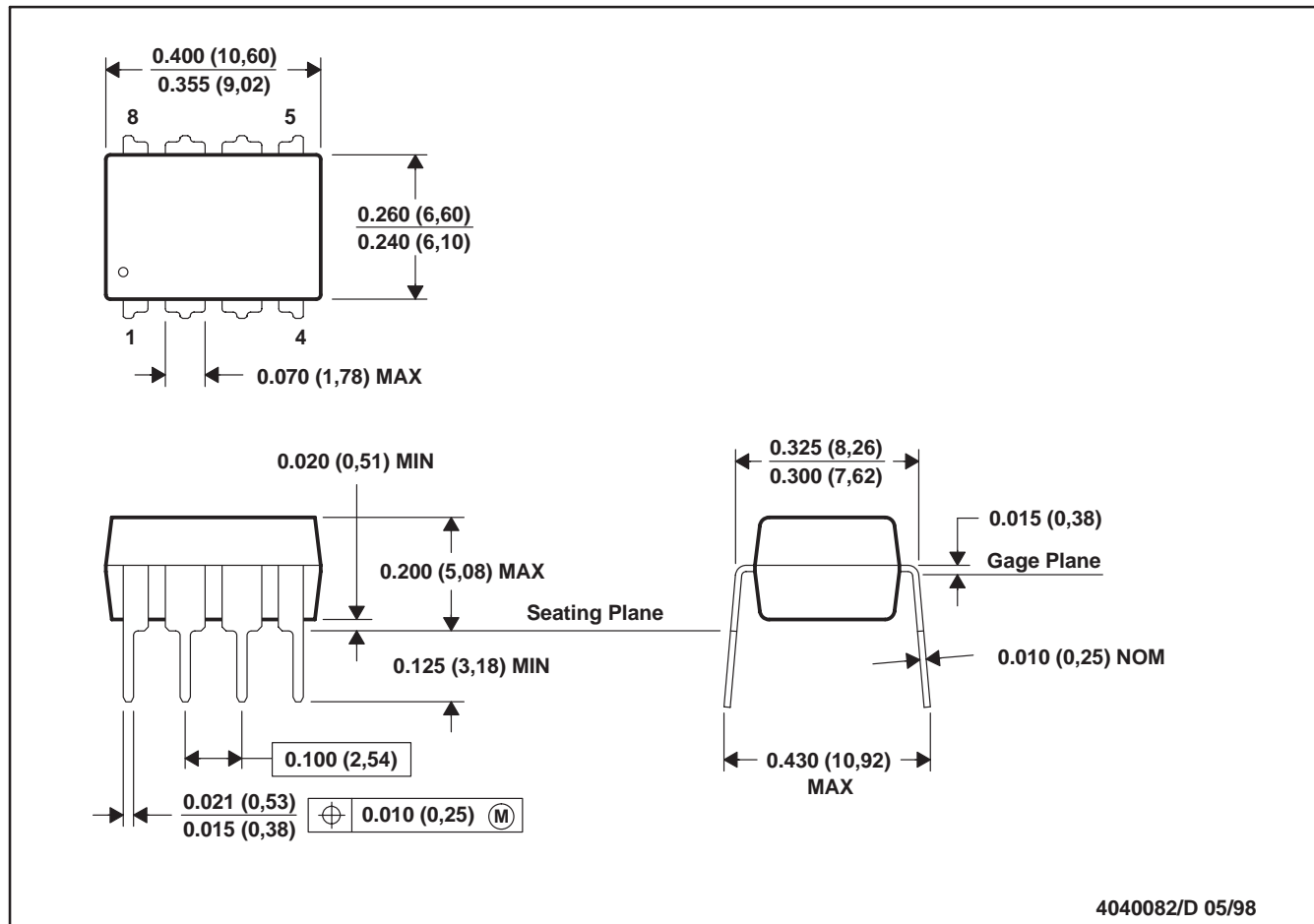

- NOTES: A. All linear dimensions are in inches (millimeters).
 B. This drawing is subject to change without notice.
 C. Falls within JEDEC MS-001

For the latest package information, go to http://www.ti.com/sc/docs/package/pkg_info.htm



POST OFFICE BOX 655303 • DALLAS, TEXAS 75265

PACKAGING INFORMATION

Orderable Device	Status ⁽¹⁾	Package Type	Package Drawing	Pins	Package Qty	Eco Plan ⁽²⁾	Lead/Ball Finish	MSL Peak Temp ⁽³⁾
SN65LBC179AD	ACTIVE	SOIC	D	8	75	Pb-Free (RoHS)	CU NIPDAU	Level-2-260C-1YEAR/ Level-1-220C-UNLIM
SN65LBC179ADR	ACTIVE	SOIC	D	8	2500	Pb-Free (RoHS)	CU NIPDAU	Level-2-260C-1YEAR/ Level-1-220C-UNLIM
SN65LBC179AP	ACTIVE	PDIP	P	8	50	Pb-Free (RoHS)	CU NIPDAU	Level-NC-NC-NC
SN65LBC179APE4	ACTIVE	PDIP	P	8	50	None	Call TI	Call TI
SN75LBC179AD	ACTIVE	SOIC	D	8	75	Pb-Free (RoHS)	CU NIPDAU	Level-2-260C-1YEAR/ Level-1-220C-UNLIM
SN75LBC179ADR	ACTIVE	SOIC	D	8	2500	Pb-Free (RoHS)	CU NIPDAU	Level-2-260C-1YEAR/ Level-1-220C-UNLIM
SN75LBC179AP	ACTIVE	PDIP	P	8	50	Pb-Free (RoHS)	CU NIPDAU	Level-NC-NC-NC
SN75LBC179APE4	ACTIVE	PDIP	P	8	50	None	Call TI	Call TI

⁽¹⁾ The marketing status values are defined as follows:

ACTIVE: Product device recommended for new designs.

LIFEBUY: TI has announced that the device will be discontinued, and a lifetime-buy period is in effect.

NRND: Not recommended for new designs. Device is in production to support existing customers, but TI does not recommend using this part in a new design.

PREVIEW: Device has been announced but is not in production. Samples may or may not be available.

OBSOLETE: TI has discontinued the production of the device.

⁽²⁾ Eco Plan - May not be currently available - please check <http://www.ti.com/productcontent> for the latest availability information and additional product content details.

None: Not yet available Lead (Pb-Free).

Pb-Free (RoHS): TI's terms "Lead-Free" or "Pb-Free" mean semiconductor products that are compatible with the current RoHS requirements for all 6 substances, including the requirement that lead not exceed 0.1% by weight in homogeneous materials. Where designed to be soldered at high temperatures, TI Pb-Free products are suitable for use in specified lead-free processes.

Green (RoHS & no Sb/Br): TI defines "Green" to mean "Pb-Free" and in addition, uses package materials that do not contain halogens, including bromine (Br) or antimony (Sb) above 0.1% of total product weight.

⁽³⁾ MSL, Peak Temp. -- The Moisture Sensitivity Level rating according to the JEDEC industry standard classifications, and peak solder temperature.

Important Information and Disclaimer: The information provided on this page represents TI's knowledge and belief as of the date that it is provided. TI bases its knowledge and belief on information provided by third parties, and makes no representation or warranty as to the accuracy of such information. Efforts are underway to better integrate information from third parties. TI has taken and continues to take reasonable steps to provide representative and accurate information but may not have conducted destructive testing or chemical analysis on incoming materials and chemicals. TI and TI suppliers consider certain information to be proprietary, and thus CAS numbers and other limited information may not be available for release.

In no event shall TI's liability arising out of such information exceed the total purchase price of the TI part(s) at issue in this document sold by TI to Customer on an annual basis.

IMPORTANT NOTICE

Texas Instruments Incorporated and its subsidiaries (TI) reserve the right to make corrections, modifications, enhancements, improvements, and other changes to its products and services at any time and to discontinue any product or service without notice. Customers should obtain the latest relevant information before placing orders and should verify that such information is current and complete. All products are sold subject to TI's terms and conditions of sale supplied at the time of order acknowledgment.

TI warrants performance of its hardware products to the specifications applicable at the time of sale in accordance with TI's standard warranty. Testing and other quality control techniques are used to the extent TI deems necessary to support this warranty. Except where mandated by government requirements, testing of all parameters of each product is not necessarily performed.

TI assumes no liability for applications assistance or customer product design. Customers are responsible for their products and applications using TI components. To minimize the risks associated with customer products and applications, customers should provide adequate design and operating safeguards.

TI does not warrant or represent that any license, either express or implied, is granted under any TI patent right, copyright, mask work right, or other TI intellectual property right relating to any combination, machine, or process in which TI products or services are used. Information published by TI regarding third-party products or services does not constitute a license from TI to use such products or services or a warranty or endorsement thereof. Use of such information may require a license from a third party under the patents or other intellectual property of the third party, or a license from TI under the patents or other intellectual property of TI.

Reproduction of information in TI data books or data sheets is permissible only if reproduction is without alteration and is accompanied by all associated warranties, conditions, limitations, and notices. Reproduction of this information with alteration is an unfair and deceptive business practice. TI is not responsible or liable for such altered documentation.

Resale of TI products or services with statements different from or beyond the parameters stated by TI for that product or service voids all express and any implied warranties for the associated TI product or service and is an unfair and deceptive business practice. TI is not responsible or liable for any such statements.

Following are URLs where you can obtain information on other Texas Instruments products and application solutions:

Products		Applications	
Amplifiers	amplifier.ti.com	Audio	www.ti.com/audio
Data Converters	dataconverter.ti.com	Automotive	www.ti.com/automotive
DSP	dsp.ti.com	Broadband	www.ti.com/broadband
Interface	interface.ti.com	Digital Control	www.ti.com/digitalcontrol
Logic	logic.ti.com	Military	www.ti.com/military
Power Mgmt	power.ti.com	Optical Networking	www.ti.com/opticalnetwork
Microcontrollers	microcontroller.ti.com	Security	www.ti.com/security
		Telephony	www.ti.com/telephony
		Video & Imaging	www.ti.com/video
		Wireless	www.ti.com/wireless

Mailing Address: Texas Instruments
Post Office Box 655303 Dallas, Texas 75265