



Features

- Carbon element
- Assortment of resistance tapers
- 45 mm and 60 mm travel lengths
- Single and dual gang elements
- Long operational life
- Tracking error within ± 2 dB

Applications

- Mixing consoles
- Drum machines
- Keyboards and synthesizers
- Equalizers

PTE Series Low Profile Slide Potentiometer

Electrical Characteristics

Standard Resistance Range1K ohms to 1 megohm
 Standard Resistance Tolerance ± 20 %
 End Resistance2 ohms max.
 Insulation Resistance @ 250 VDC100 megohms min.
 Dielectric Withstanding Voltage250 VAC
 Tracking Error ± 2 dB
 Standard TaperLinear, Audio
 Power Rating
 Linear0.2 watt
 Audio0.1 watt
 Slider Noise100 mV max.

Environmental Characteristics

Operational Life100,000 cycles
 TR Shift ± 15 %
 Operating Temperature Range-10 °C to +55 °C
 Resistance to Solder Heat ± 5 %

Mechanical Characteristics

Mechanical TravelLength ± 0.5 mm
 Operating Force50 gf
 Stop Strength10 kgf min.
 Shaft Axial Force5 kgf min.
 Shaft Wobble2(2 x L/25) mm p-p max.
 Soldering Condition
 Manual300 °C ± 5 °C for 3 sec.
 Wave260 °C ± 5 °C for 5 sec.
 WashNot recommended

How To Order

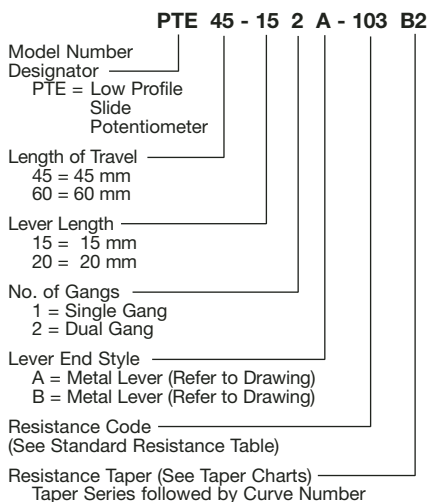

Product Dimensions

45 mm Length of Travel Lever End Style "B"

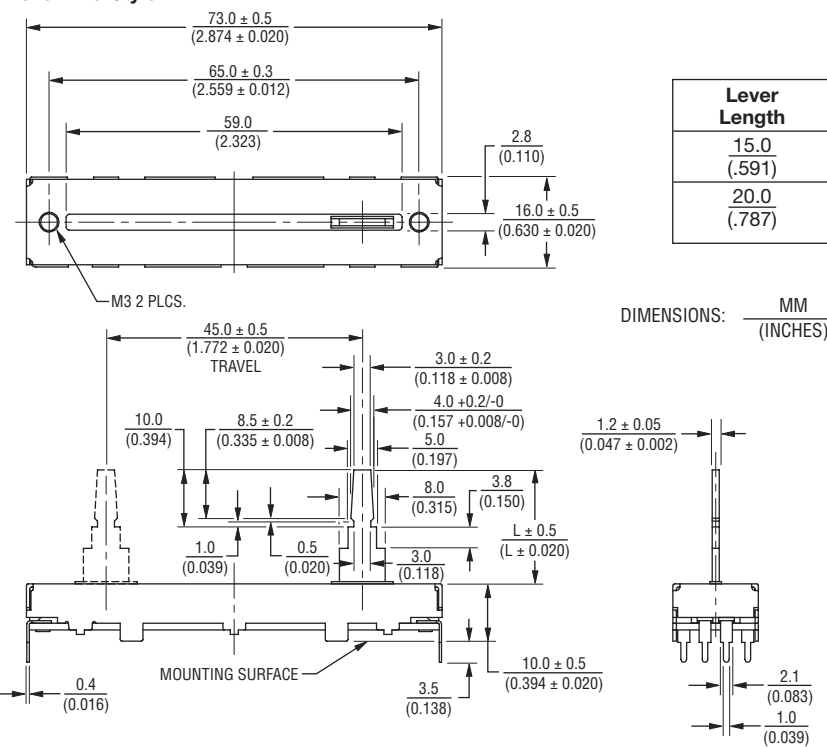

Mounting Hole Detail

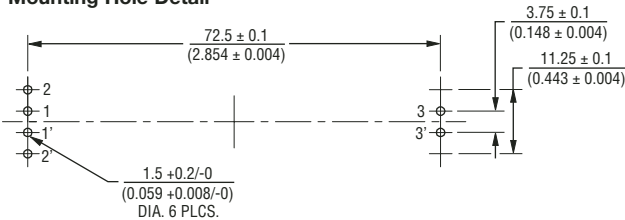

Standard Resistance Table

Resistance (Ohms)	Resistance Code
1,000	102
2,000	202
5,000	502
10,000	103
20,000	203
50,000	503
100,000	104
200,000	204
500,000	504
1,000,000	105

Schematics

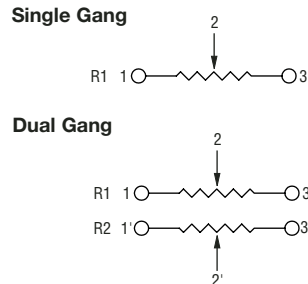

*RoHS Directive 2002/95/EC Jan 27 2003 including Annex. Specifications are subject to change without notice. Customers should verify actual device performance in their specific applications.

PTE Series Low Profile Slide Potentiometer

BOURNS®

Product Dimensions

60 mm Length of Travel
Lever End Style "A"

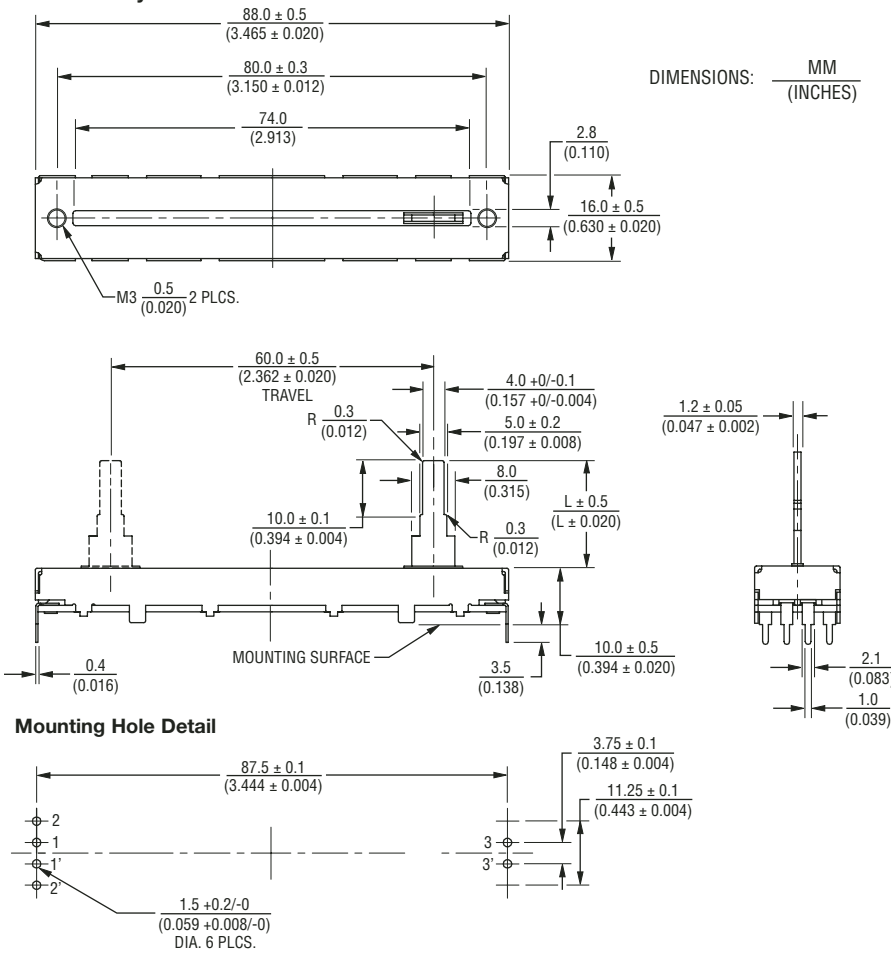

Tapers

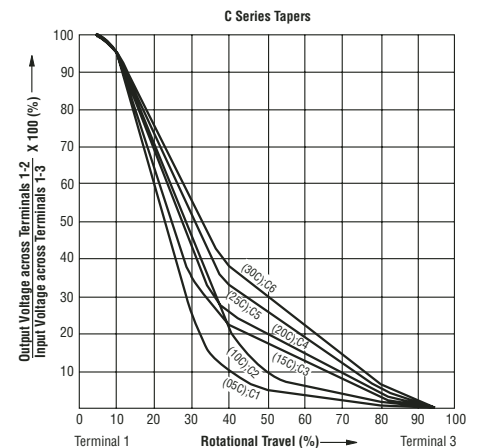
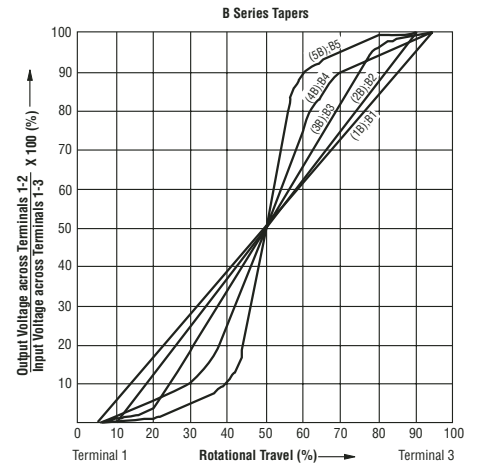
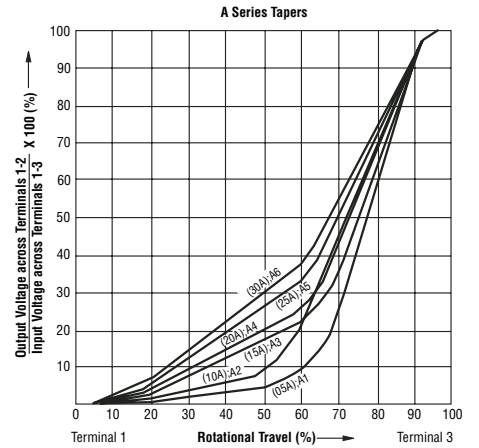

Sensors & Controls Division

Asia-Pacific: TEL +886-2 25624117 • FAX +886-2 25624116

Europe: TEL +41-41 7685555 • FAX +41-41 7685510

The Americas: TEL +1-951 781-5500 • FAX +1-951 781-5700

www.bourns.com

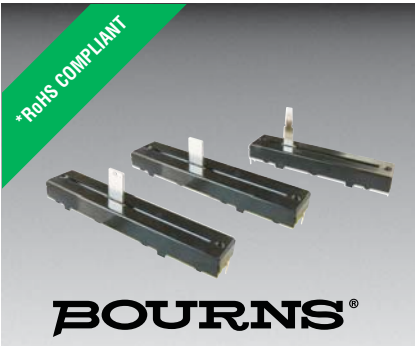

Features

- Carbon element
- Assortment of resistance tapers
- 45 mm and 60 mm travel lengths
- Single and dual gang elements
- Long operational life
- Tracking error within ± 2 dB
- Various lever styles



PTE Series Low Profile Slide Potentiometer

Electrical Characteristics

Standard Resistance Range 1K ohms to 1 megohm
 Standard Resistance Tolerance... ± 20 %
 End Resistance 2 ohms max.
 Insulation Resistance @ 100 VDC 100 megohms min.
 Dielectric Withstanding Voltage 250 VAC
 Tracking Error ± 2 dB
 Standard Taper Linear, Audio
 Power Rating
 Linear 0.2 watt
 Audio 0.1 watt
 Slider Noise 100 mV max.

Environmental Characteristics

Operational Life 100,000 cycles
 TR Shift ± 15 %
 Operating Temperature Range -10 °C to $+55$ °C
 Resistance to Solder Heat..... ± 5 %

Mechanical Characteristics

Mechanical Angle 300 ° ± 5 °
 Mechanical Travel..... Length ± 0.5 mm
 Operating Force 50 gf
 Stop Strength 5 kgf min.
 Shaft Axial Force 5 kgf min.
 Shaft Wobble.. $2(2 \times L/25)$ mm p-p max.
 Soldering Condition
 Manual 300 °C ± 5 °C for 3 sec.
 Wave 260 °C ± 5 °C for 5 sec.
 Wash Not recommended

Standard Resistance Table

Resistance (Ohms)	Resistance Code
1,000	102
2,000	202
5,000	502
10,000	103
20,000	203
50,000	503
100,000	104
200,000	204
500,000	504
1,000,000	105

Product Dimensions

45 mm Length of Travel Lever End Style "B"

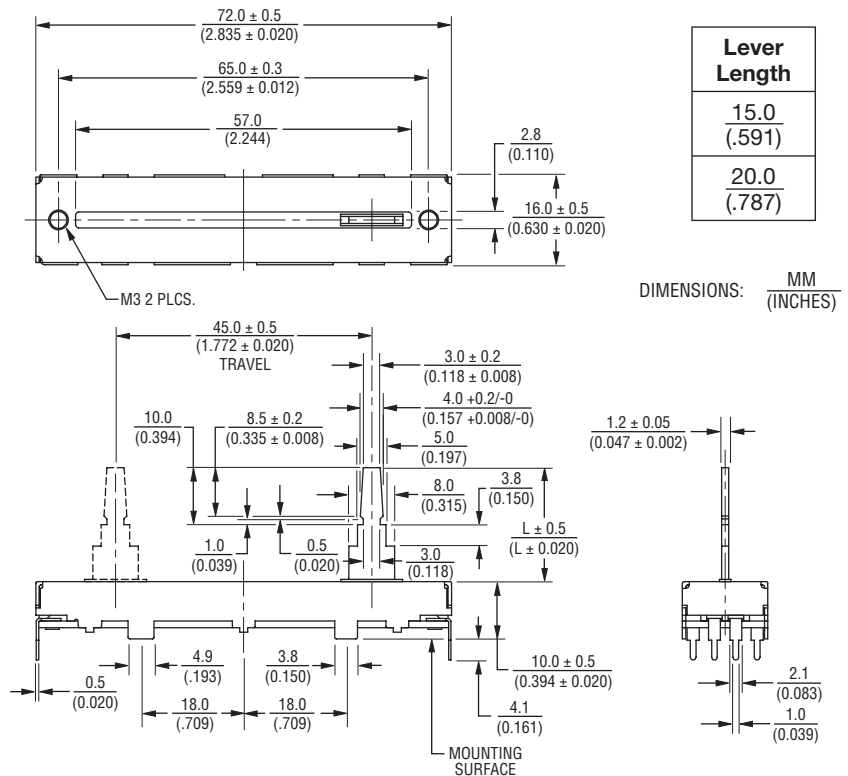

Mounting Hole Detail

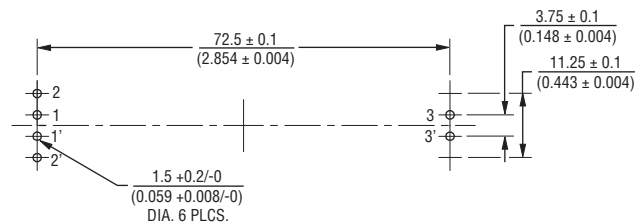

Schematics

Single Gang

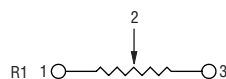

Dual Gang

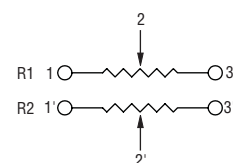

*RoHS Directive 2002/95/EC Jan 27 2003 including Annex
 Specifications are subject to change without notice.
 Customers should verify actual device performance in their specific applications.

Applications

- Mixing consoles
- Drum machines
- Keyboards and synthesizers
- Equalizers

PTE Series Low Profile Slide Potentiometer

BOURNS®

Product Dimensions

60 mm Length of Travel
Lever End Style "A"

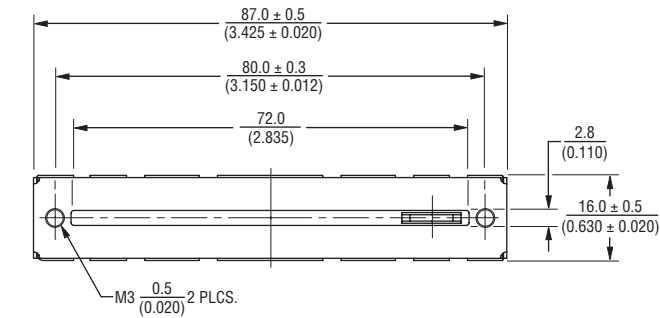

Lever Length	
15.0	(.591)
20.0	(.787)

DIMENSIONS: $\frac{\text{MM}}{\text{(INCHES)}}$

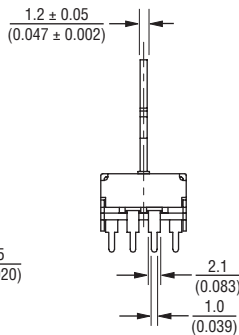
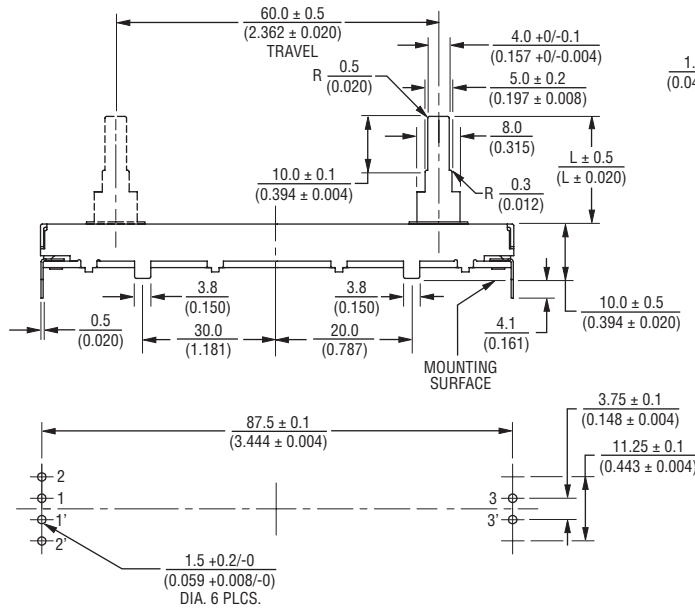

Tapers

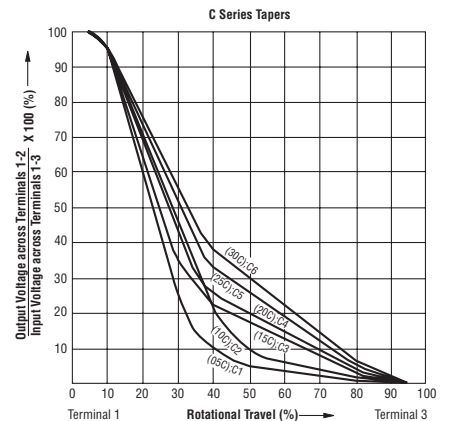
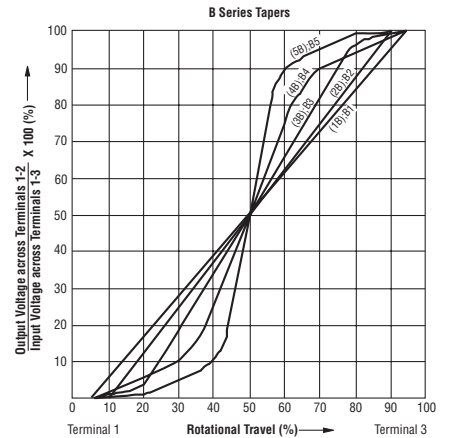
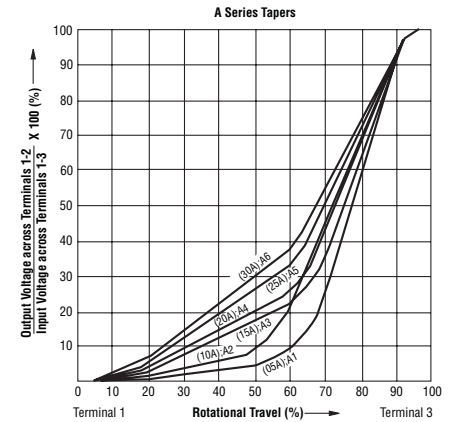

Specifications are subject to change without notice.
Customers should verify actual device performance in their specific applications.

PTE Series Low Profile Slide Potentiometer

BOURNS®

Additional Lever End Styles

How To Order

Lever End Style "C"

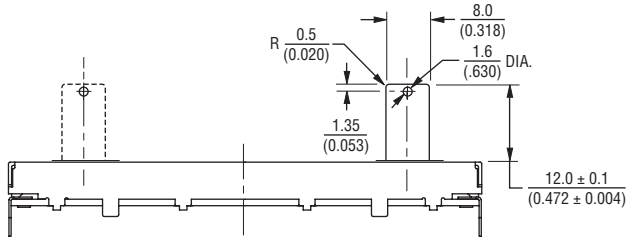

DIMENSIONS: $\frac{\text{MM}}{\text{(INCHES)}}$

Lever End Style "D"

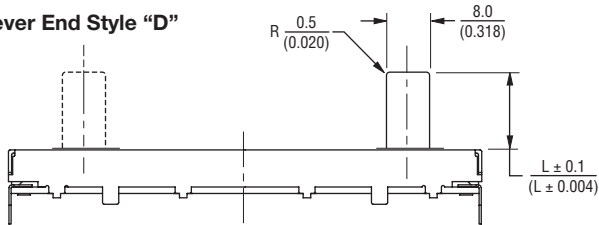

Lever Length
$\frac{12.8}{(.504)}$
$\frac{20.0}{(.787)}$

Lever End Style "E"

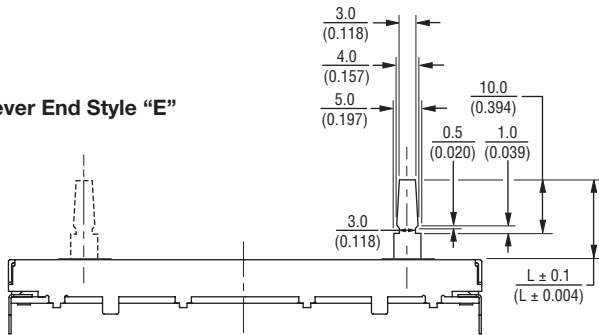

Lever Length
$\frac{15.0}{(.591)}$
$\frac{20.0}{(.787)}$

PTE 45 - 15 2 A - 103 B2

Model Number _____

Designator _____
 PTE = Low Profile
 Slide
 Potentiometer

Length of Travel _____
 45 = 45 mm
 60 = 60 mm

Lever Length _____
 12 = 12 mm (Available with
 Lever End Style C)
 13 = 12.8 mm (Available with
 Lever End Style D)
 15 = 15 mm (Available with
 Lever End Styles A,B,E)
 20 = 20 mm (Available with
 Lever End Styles A,B,D,E)

No. of Gangs _____
 1 = Single Gang
 2 = Dual Gang

Metal Lever End Style _____
 (Refer to Drawings)
 • A • D
 • B • E
 • C

Resistance Code _____
 (See Standard Resistance Table)

Resistance Taper (See Taper Charts) _____
 Taper Series followed by Curve Number