

WIREWOUND MULTITURN TYPE **M series**

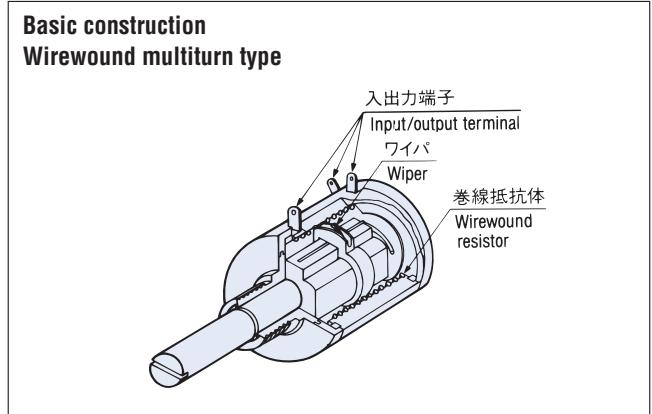
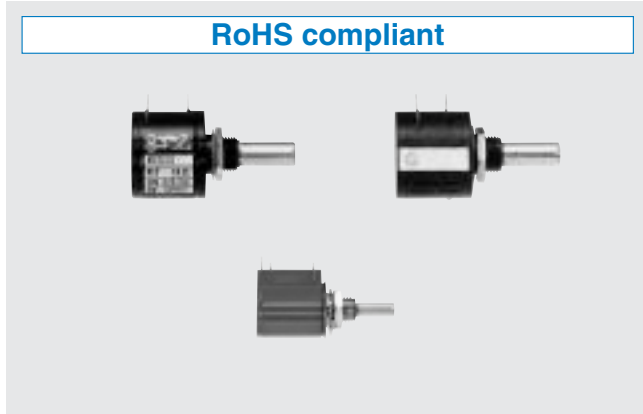

FEATURES

- Line-up includes products ranging from 3 to 10 turns
- Cost effective (M-22E10) in house comparison
- Dial can be attached (M-22 series only)

PART NUMBER DESIGNATION

M - 1 3 0 3 1 0 0

Series name

M-1303, M-1305, M-22S10
M-22E10-000, M-22E10-050

Nominal resistance value (Ω)

100, 200, 500, 1 k, 2 k, 5 k, 10 k, 20 k, 50 k

LIST OF PART NUMBERS

No. of turn	Item	Nominal resistance value (Ω)	Part number
3 turns		100, 200, 500, 1 k, 2 k, 5 k, 10 k, 20 k	M-1303 Resistance value ※1
			M-1305 Resistance value
5 turns		100, 200, 500, 1 k, 2 k, 5 k, 10 k, 20 k, 50 k	M-22S10 Resistance value
			M-22E10-000 M-22E10-050 Resistance value ※2

※1 : M-1303 200 Ω model is manufactured upon receipt of order basis.
 ※2 : For M-22E10 series, please refer to the drawing for its shaft size.

※ Verify the above part numbers when placing orders.

STANDARD SPECIFICATIONS

Item	Part number	M-13 series		M-22 series		
		M-1303	M-1305	M-22S10	M-22E10	
Resistance tolerance	%	± 5				
Independent linearity	%	± 0.5		± 0.2		
End resistance, maximum		2 % or 4 Ω, whichever is greater		0.5 % or 1 Ω, whichever is greater		
Effective electrical angle		1080°	1800°	3600°		
Mechanical angle		1080° ±10°	1800° ±10°	3600° ^{+10°} ₀		
Power rating	W	0.75	1	2		
Dielectric strength	Vrms	1000 1 min				
Insulation resistance	MΩ minimum	1000 (at DC 500 V)				
Rotational torque	mN·m {gf·cm} maximum	14.7 {150}		9.81 {100}		
Strength of tighten screw	N·m {kgf·cm} maximum	0.98 {10}			M-22E10-000 0.784 (8)	M-22E10-050 0.588 (6)
Stop strength	N·m {kgf·cm} maximum	0.147 {1.5}		0.196 {2}		
Peak noise	Ω maximum	20 (at 4 min ⁻¹)				
Temp. coefficient resistance	ppm/°C	± 50				
Operating temp. range	°C	-40 ~ 85				
Rotational life		15000 cycles		25000 cycles		
Net weight	g	Approx. 7		Approx. 19	Approx. 17	

NOMINAL RESISTANCE • RESOLUTION • RATED VOLTAGE • RATED CURRENT

Nominal resistance value (Ω)	Resolution (%)		Rated voltage (V)		Rated current (mA)	
	M-22S10	M-22E10	M-22S10	M-22E10	M-22S10	M-22E10
100	0.041		14.1		141.8	
200	0.036		20.0		100.0	
500	0.029		31.6		63.2	
1 k	0.025		44.7		44.7	
2 k	0.018		63.2		31.6	
5 k	0.017		100.0		20.0	
10k	0.018		141.1		14.1	
20 k	0.014		200.1		10.1	
50 k	0.011		316.2	200.0	6.3	
100 k	↻ 0.009		↻ 450.0	↻ 200.0	↻ 4.47	

Nominal resistance value (Ω)	Resolution (%)		Rated voltage (V)		Rated current (mA)	
	M-1303	M-1305	M-1303	M-1305	M-1303	M-1305
100	0.190	0.137	8.7	10.0	86.2	100.0
200	↻ 0.154	0.095	↻ 12.2	14.1	↻ 61.5	70.9
500	0.115	0.078	19.4	22.4	38.7	44.6
1 k	0.072	0.057	27.4	31.6	28.5	31.6
2 k	0.056	0.047	38.7	44.7	19.4	22.4
5 k	0.069	0.051	61.2	70.7	12.3	14.1
10 k	0.053	0.039	86.6	100.0	8.7	10.0
20 k	0.038	0.032	122.5	141.4	6.1	7.1

RATED POWER DERATING CURVE

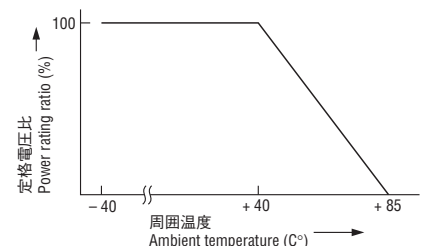

The products indicated by ↻ mark are manufactured upon receipt of order basis.

M series POTENTIOMETERS

OUTLINE DIMENSIONS

(Unit: mm)

- M-1303 (3 turns)
- M-1305 (5 turns)

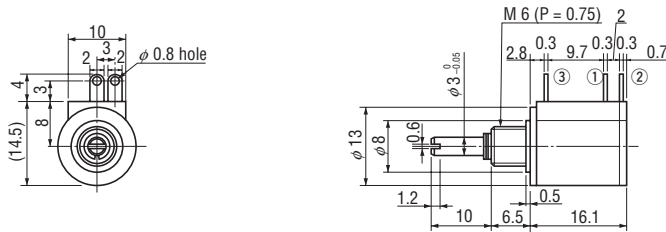

結線図
Wiring diagram

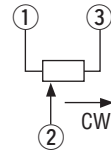

- M-22S10 (10 turns)

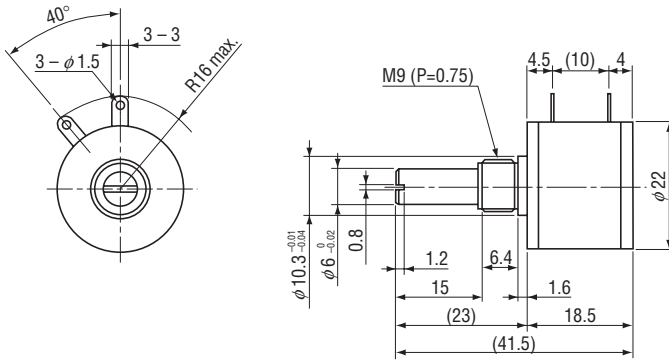

- M-22E10 (10 turns)

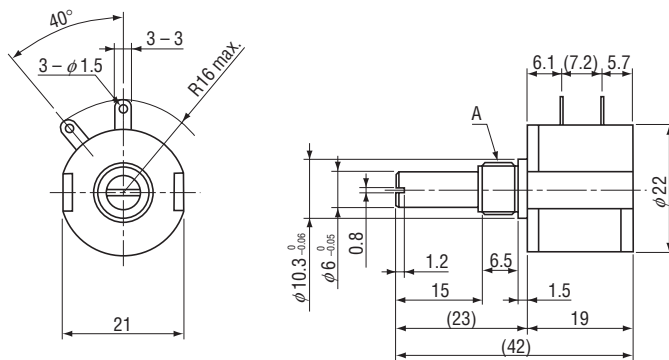

Part number	Mark	A
M-22E10-000		3/8" 32 UNEF
M-22E10-050		M 9 (P = 0.75)

- MC1003, JC10, M-1303, M-1305 in common
- For mm size (M-22E10-050, M-22S10 in common)
- For inch size (M-22E10-000, M-22E10-010 in common)

