

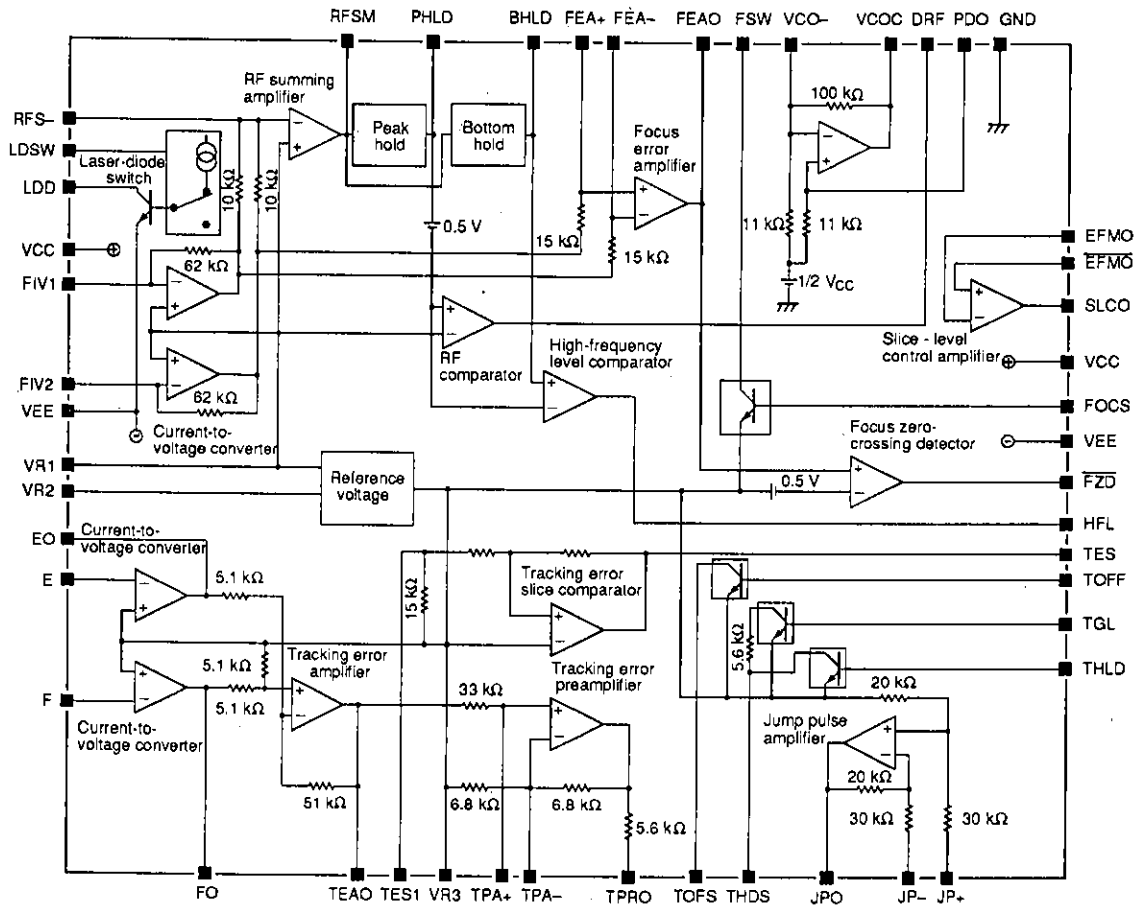

# LA9200NM,9201M

## BLOCK DIAGRAM



## PIN DESCRIPTION

Number	Pin	Description
1	FO	Photodiode F current-to-voltage converter output
2	TEAO	Tracking error amplifier output
3	TES1	Tracking error slice comparator input
4	VR3	Reference voltage
5	TPA+	Tracking error preamplifier non-inverting input
6	TPA-	Tracking error preamplifier inverting input
7	TPRO	Tracking error preamplifier output
8	TOFS	Tracking OFF switch
9	THDS	Tracking hold switch
10	JPO	Jump pulse amplifier output
11	JP-	Jump pulse amplifier inverting input
12	JP+	Jump pulse amplifier non-inverting input
13	THLD	Tracking hold control
14	TGL	Tracking servocontroller gain control
15	TOFF	Tracking OFF control

## LA9200NM,9201M

Number	Pin	Description
16	TES	Tracking error slice comparator output
17	HFL	High-frequency level comparator
18	FZD	Focus zero-crossing detector output
19	VEE	Supply voltage
20	FOCS	Focus switch control
21	VCC	Supply voltage
22	SLCO	Slice level control output
23	EFMO	Eight-to-fourteen modulation control non-inverting input
24	EFMO	Eight-to-fourteen modulation control inverting input
25	GND	Ground
26	PDO	Phase detector input
27	DRF	Focus detect RF comparator output
28	VCOC	VCO control amplifier output
29	VCO-	VCO control amplifier inverting input
30	FSW	Focus switch
31	FEAO	Focus error amplifier output
32	FEA-	Focus error amplifier inverting input
33	FEA+	Focus error amplifier non-inverting input
34	BHLD	Negative-peak (bottom) hold output
35	PHLD	Peak hold output
36	RFSM	RF summing amplifier output
37	RFS-	RF summing amplifier inverting input
38	LDSW	Laser-diode switch
39	LDD	Laser-diode driver
40	VCC	Supply voltage
41	FIV1	Photodiodes A and C current-to-voltage converter input
42	FIV2	Photodiodes B and D current-to-voltage converter input
43	VEE	Supply voltage
44	VR1	Reference voltage
45	VR2	Reference voltage
46	EO	Photodiode E current-to-voltage converter output
47	E	Photodiode E current-to-voltage converter input
48	F	Photodiode F current-to-voltage converter input



## LA9200NM,9201M

### Electrical Characteristics

$V_{CC} = 5\text{ V}$ ,  $V_{EE} = -5\text{ V}$ ,  $T_a = 25\text{ deg. C}$

Parameter	Symbol	Condition	Rating			Unit
			min	typ	max	
Supply current	$I_{CC}$		12	17	22	mA
	$I_{EE}$	LDSW OFF	11	15.5	20	mA

### RF amplifier

$V_{CC} = 5\text{ V}$ ,  $V_{EE} = -5\text{ V}$ ,  $T_a = 25\text{ deg. C}$

Parameter	Symbol	Condition	Rating			Unit
			min	typ	max	
DC offset voltage	$V_{36-0}$	Pins 41 and 42 are open circuit.	-300	-120	0	mV
Voltage gain	$G_{V-36}$	Pins 41 and 42 source impedance $R_g = 10\text{ k}\Omega$ , $R_{36\text{ to }37} = 22\text{ k}\Omega$ , $f = 200\text{ kHz}$	25	28	31	dB
HIGH-level output voltage	$V_{36-H}$	$R_L = 10\text{ k}\Omega$	4.0	4.2	4.3	V
LOW-level output voltage	$V_{36-L}$	$R_L = 10\text{ k}\Omega$	-1.6	-1.3	-1.2	V
Passband frequency response variation	$\Delta A_V$	$f = 1\text{ MHz}/200\text{ kHz}$	-3.0	-0.5	3.0	dB

### Focus error amplifier

$V_{CC} = 5\text{ V}$ ,  $V_{EE} = -5\text{ V}$ ,  $T_a = 25\text{ deg. C}$

Parameter	Symbol	Condition	Rating			Unit
			min	typ	max	
DC offset voltage	$V_{31-0}$	Pins 41 and 42 are open circuit.	-150	0	150	mV
Voltage gain	$G_{V-31}$	$f = 1\text{ kHz}$ , $R_{33\text{ to GND}} = 120\text{ k}\Omega$ , $R_{31\text{ to }32} = 120\text{ k}\Omega$	31	34	37	dB
Voltage gain differential	$\Delta G_V$	Pin 41 input vs. pin 42 input	-1.0	0	1.0	dB
HIGH-level output voltage	$V_{31-H}$	$R_L = 10\text{ k}\Omega$	4.1	4.25	4.6	V
LOW-level output voltage	$V_{31-L}$	$R_L = 10\text{ k}\Omega$	-4.6	-4.25	-4.1	V
Operating frequency	$f_{max}$		20	200	-	kHz

### Peak detector and hold circuit

$V_{CC} = 5\text{ V}$ ,  $V_{EE} = -5\text{ V}$ ,  $T_a = 25\text{ deg. C}$

Parameter	Symbol	Condition	Rating			Unit
			min	typ	max	
DC offset voltage	$V_{35\text{ to }36}$	Pins 41 and 42 are open circuit.	-100	-40	20	mV
Output voltage	$V_{35-0}$	$I_{41} = I_{42} = 5\text{ }\mu\text{A}$	1.0	1.2	1.4	V

## LA9200NM,9201M

### Negative-peak (bottom) detector and hold circuit

$V_{CC} = 5\text{ V}$ ,  $V_{EE} = -5\text{ V}$ ,  $T_a = 25\text{ deg. C}$

Parameter	Symbol	Condition	Rating			Unit
			min	typ	max	
DC offset voltage	$V_{34\text{ to }35}$	Pins 41 and 42 are open circuit.	-100	0	100	mV
Output voltage	$V_{34,0}$	$I_{41} = I_{42} = 5\text{ }\mu\text{A}$	1.0	1.2	1.4	V

### Focus detect RF detector

$V_{CC} = 5\text{ V}$ ,  $V_{EE} = -5\text{ V}$ ,  $T_a = 25\text{ deg. C}$

Parameter	Symbol	Condition	Rating			Unit
			min	typ	max	
HIGH-level output voltage	$V_{27-H}$	$I_{41} = I_{42} = 3\text{ }\mu\text{A}$	4.0	4.2	4.5	V
LOW-level output voltage	$V_{27-L}$	$I_{41} = I_{42} = 1\text{ }\mu\text{A}$	0	0	0.5	V
HIGH-level offset voltage	$V_{35-1}$	$V_{27}$ is HIGH	0.7	-	-	V
LOW-level offset voltage	$V_{35-2}$	$V_{27}$ is LOW	-	-	0.1	V

### Focus zero-crossing comparator

$V_{CC} = 5\text{ V}$ ,  $V_{EE} = -5\text{ V}$ ,  $T_a = 25\text{ deg. C}$

Parameter	Symbol	Condition	Rating			Unit
			min	typ	max	
HIGH-level output voltage	$V_{18-H}$	Pins 41 and 42 are open circuit.	4.0	4.2	4.5	V
LOW-level output voltage	$V_{18-L}$	$I_{42} = 2\text{ }\mu\text{A}$	-	0	0.5	V
HIGH-level offset voltage	$V_{31-1}$	$V_{18}$ is HIGH	-0.35	-	-	V
LOW-level offset voltage	$V_{31-2}$	$V_{18}$ is LOW	-	-	-0.65	V

### High-frequency (HF) comparator

$V_{CC} = 5\text{ V}$ ,  $V_{EE} = -5\text{ V}$ ,  $T_a = 25\text{ deg. C}$

Parameter	Symbol	Condition	Rating			Unit
			min	typ	max	
HIGH-level output voltage	$V_{17-H}$	Pins 41 and 42 are open circuit.	4.0	4.2	4.5	V
LOW-level output voltage	$V_{17-L}$	$V_{35} = 0.8\text{ V}$ , $V_{34} = 0\text{ V}$	0	0	0.5	V
LOW-level offset voltage	$V_{35-1}$	$V_{17}$ is LOW, $V_{34} = 0\text{ V}$	0.7	-	-	V
HIGH-level offset voltage	$V_{35-2}$	$V_{17}$ is HIGH, $V_{34} = 0\text{ V}$	-	-	0.3	V
Operating frequency	$f_{\text{max}}$		100	500	-	kHz

## LA9200NM,9201M

### Tracking error amplifier

$V_{CC} = 5\text{ V}$ ,  $V_{EE} = -5\text{ V}$ ,  $T_a = 25\text{ deg. C}$

Parameter	Symbol	Condition	Rating			Unit
			min	typ	max	
DC offset voltage	$V_{2-0}$	$R_{46\text{ to }47} = 150\text{ k}\Omega$ , $R_{48\text{ to }1} = 150\text{ k}\Omega$	-150	0	150	mV
Voltage gain	$G_{V-2}$	Pins 47 and 48 source impedance $R_G = 150\text{ k}\Omega$	17	20	23	dB
Voltage gain differential	$\Delta G_V$	Pin 47 input vs. pin 48 input	-1.0	0	1.0	dB
HIGH-level maximum output voltage	$V_{2-H}$	$R_L = 10\text{ k}\Omega$	3.9	4.15	4.4	V
LOW-level maximum output voltage	$V_{2-L}$	$R_L = 10\text{ k}\Omega$	-4.4	-4.15	-3.9	V
Operating frequency	$f_{max}$		20	200	-	kHz

### Tracking preamplifier

$V_{CC} = 5\text{ V}$ ,  $V_{EE} = -5\text{ V}$ ,  $T_a = 25\text{ deg. C}$

Parameter	Symbol	Condition	Rating			Unit
			min	typ	max	
DC offset voltage	$V_{7-0}$	$R_{46\text{ to }47} = 150\text{ k}\Omega$ , $R_{48\text{ to }1} = 150\text{ k}\Omega$ . Pins 5, 6 and 7 are open circuit.	-250	0	250	mV
Voltage gain	$G_{V-7}$	Pins 47 and 48 source impedance $R_G = 150\text{ k}\Omega$ . Pins 5, 6 and 7 are open circuit.	23	26	29	dB
HIGH-level maximum output voltage	$V_{7-H}$		3.9	4.2	4.4	V
LOW-level maximum output voltage	$V_{7-L}$		-4.4	-4.2	-3.9	V
Operating frequency	$f_{max}$		20	200	-	kHz

### Tracking error slice comparator

$V_{CC} = 5\text{ V}$ ,  $V_{EE} = -5\text{ V}$ ,  $T_a = 25\text{ deg. C}$

Parameter	Symbol	Condition	Rating			Unit
			min	typ	max	
HIGH-level output voltage	$V_{16-H1}$	$V_3 = 0.5\text{ V}$ , $R_3 = 15\text{ k}\Omega$	4.0	4.2	4.5	V
	$V_{16-H2}$	$V_3 = 0.5\text{ to }0.1\text{ V}$ (hysteresis), $R_3 = 15\text{ k}\Omega$	4.0	4.2	4.5	
LOW-level output voltage	$V_{16-L1}$	$V_3 = -0.5\text{ V}$ , $R_3 = 15\text{ k}\Omega$	0	0	0.5	V
	$V_{16-L2}$	$V_3 = -0.5\text{ to }0\text{ V}$ (hysteresis), $R_3 = 15\text{ k}\Omega$	0	0	0.5	
Operating frequency	$f_{max}$	0.5 V sine wave, $R_3 = 15\text{ k}\Omega$	100	500	-	kHz

## LA9200NM,9201M

### Jump pulse amplifier

$V_{CC} = 5\text{ V}$ ,  $V_{EE} = -5\text{ V}$ ,  $T_a = 25\text{ deg. C}$

Parameter	Symbol	Condition	Rating			Unit
			min	typ	max	
DC offset voltage	$V_{10-0}$	$V_{11} = 0\text{ V}$ , $V_{12} = 0\text{ V}$	-20	0	20	mV
HIGH-level maximum output voltage	$V_{10-H}$	$V_{12} = 5.0\text{ V}$ , $V_{11} = 0\text{ V}$	3.0	3.3	3.6	V
LOW-level maximum output voltage	$V_{10-L}$	$V_{11} = 5.0\text{ V}$ , $V_{12} = 0\text{ V}$	-3.6	-3.3	-3.0	V
Operating frequency	$f_{max}$		100	150	-	kHz

### VCO control amplifier

$V_{CC} = 5\text{ V}$ ,  $V_{EE} = -5\text{ V}$ ,  $T_a = 25\text{ deg. C}$

Parameter	Symbol	Condition	Rating			Unit
			min	typ	max	
DC offset voltage	$V_{28-0}$		2.2	2.4	2.6	V
Voltage gain	$G_{V-28}$	$V_{26} = 100\text{ mV}$ , $f = 1\text{ kHz}$	17	20	23	dB
HIGH-level maximum output voltage	$V_{28-H}$	$V_{26} = 5.0\text{ V}$ , $R_{26} = 10\text{ k}\Omega$	4.0	4.3	4.5	V
LOW-level maximum output voltage	$V_{28-L}$	$V_{26} = 0\text{ V}$ , $R_{26} = 10\text{ k}\Omega$	-	0.7	1.0	V
Operating frequency	$f_{resp}$	Sine wave input on pin 26	200	500	-	kHz

### Slice level control amplifier

$V_{CC} = 5\text{ V}$ ,  $V_{EE} = -5\text{ V}$ ,  $T_a = 25\text{ deg. C}$

Parameter	Symbol	Condition	Rating			Unit
			min	typ	max	
DC offset voltage	$V_{22-0}$	$R_{22\text{ to }24} = 10\text{ k}\Omega$ , $V_{23} = 2.5\text{ V}$ , $R_{23} = 10\text{ k}\Omega$	2.4	2.5	2.6	V
Voltage gain	$G_{V-22}$	$R_g = 1\text{ k}\Omega$ , $f_{24} = 1\text{ kHz}$	17	20	23	dB
HIGH-level maximum output voltage	$V_{22-H}$		4.0	4.25	4.5	V
LOW-level maximum output voltage	$V_{22-L}$		-	0.75	1.0	V

### Focus switch

$V_{CC} = 5\text{ V}$ ,  $V_{EE} = -5\text{ V}$ ,  $T_a = 25\text{ deg. C}$

Parameter	Symbol	Condition	Rating			Unit
			min	typ	max	
DC offset voltage	$V_{30-1}$	$V_{30} = 5.0\text{ V}$ , $R_{30} = 10\text{ k}\Omega$ , $V_{20} = 5.0\text{ V}$	-30	10	70	mV
	$V_{30-2}$	$V_{30} = 1.0\text{ V}$ , $R_{30} = 10\text{ k}\Omega$ , $V_{20} = 5.0\text{ V}$	-10	0	40	mV



## LA9200NM,9201M

Parameter	Symbol	Condition	Rating			Unit
			min	typ	max	
DC offset voltage	V <sub>30-3</sub>	V <sub>30</sub> = -5.0 V, R <sub>30</sub> = 10 kΩ, V <sub>20</sub> = 5.0 V	-35	-18	5	mV
	V <sub>30-4</sub>	V <sub>30</sub> = -1.0 V, R <sub>30</sub> = 10 kΩ, V <sub>20</sub> = 5.0 V	-15	-3	30	mV

### Tracking OFF switch

V<sub>CC</sub> = 5 V, V<sub>EE</sub> = -5 V, T<sub>a</sub> = 25 deg. C

Parameter	Symbol	Condition	Rating			Unit
			min	typ	max	
DC offset voltage	V <sub>8-1</sub>	V <sub>8</sub> = 5.0 V, R <sub>8</sub> = 20 kΩ, V <sub>15</sub> = 5.0 V	-20	14	50	mV
	V <sub>8-2</sub>	V <sub>8</sub> = 1.0 V, R <sub>8</sub> = 20 kΩ, V <sub>15</sub> = 5.0 V	-10	5	40	mV
	V <sub>8-3</sub>	V <sub>8</sub> = -5.0 V, R <sub>8</sub> = 20 kΩ, V <sub>15</sub> = 5.0 V	-25	-10	5	mV
	V <sub>8-4</sub>	V <sub>8</sub> = -1.0 V, R <sub>8</sub> = 20 kΩ, V <sub>15</sub> = 5.0 V	-15	0	15	mV

### Tracking gain switch

V<sub>CC</sub> = 5 V, V<sub>EE</sub> = -5 V, T<sub>a</sub> = 25 deg. C

Parameter	Symbol	Condition	Rating			Unit
			min	typ	max	
DC offset voltage	V <sub>9-1</sub>	V <sub>9</sub> = 5.0 V, R <sub>9</sub> = 20 kΩ, V <sub>14</sub> = 5.0 V	0.9	1.1	1.3	V
	V <sub>9-2</sub>	V <sub>9</sub> = 1.0 V, R <sub>9</sub> = 20 kΩ, V <sub>14</sub> = 5.0 V	0.15	0.23	0.35	V
	V <sub>9-3</sub>	V <sub>9</sub> = -5.0 V, R <sub>9</sub> = 20 kΩ, V <sub>14</sub> = 5.0 V	-1.3	-1.16	-0.9	V
	V <sub>9-4</sub>	V <sub>9</sub> = -1.0 V, R <sub>9</sub> = 20 kΩ, V <sub>14</sub> = 5.0 V	-0.3	-0.2	-0.1	V

### Tracking hold switch

V<sub>CC</sub> = 5 V, V<sub>EE</sub> = -5 V, T<sub>a</sub> = 25 deg. C

Parameter	Symbol	Condition	Rating			Unit
			min	typ	max	
DC offset voltage	V <sub>9-5</sub>	V <sub>9</sub> = 5.0 V, R <sub>9</sub> = 20 kΩ, V <sub>13</sub> = 5.0 V	-20	14	50	mV
	V <sub>9-6</sub>	V <sub>9</sub> = 1.0 V, R <sub>9</sub> = 20 kΩ, V <sub>13</sub> = 5.0 V	-10	5	40	mV
	V <sub>9-7</sub>	V <sub>9</sub> = -5.0 V, R <sub>9</sub> = 20 kΩ, V <sub>13</sub> = 5.0 V	-25	-10	5	mV
	V <sub>9-8</sub>	V <sub>9</sub> = -1.0 V, R <sub>9</sub> = 20 kΩ, V <sub>13</sub> = 5.0 V	-15	0	15	mV

# LA9200NM,9201M

## Laser ON/OFF switch

$V_{CC} = 5\text{ V}$ ,  $V_{EE} = -5\text{ V}$ ,  $T_a = 25\text{ deg. C}$

Parameter	Symbol	Condition	Rating			Unit
			min	typ	max	
ON voltage	$V_{38-ON}$	$R_{39\text{ to }25} = 47\ \Omega$ , $V_{38} = 0\text{ V}$ , $R_{38} = 1\text{ k}\Omega$	-	-4.4	-4.0	V
OFF voltage	$V_{38-OFF}$	$R_{39\text{ to }25} = 47\ \Omega$ , $V_{38} = 4.5\text{ V}$ , $R_{38} = 1\text{ k}\Omega$	-0.1	0	0	V

## Measurement Circuit

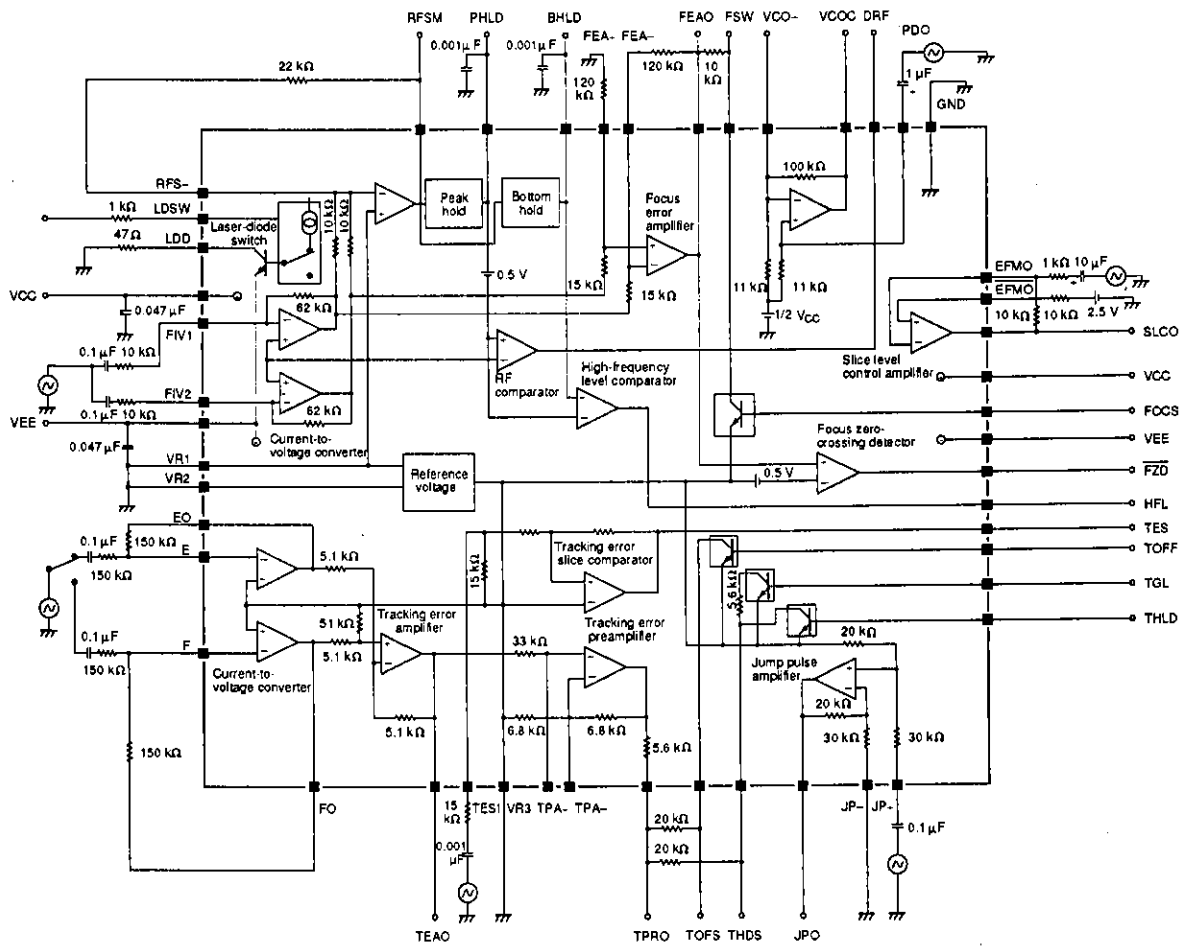

Typical Performance Characteristics

RF summing amplifier frequency response

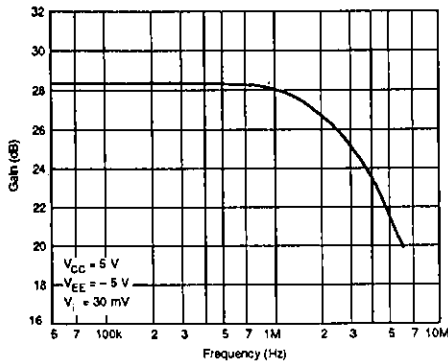

Tracking error amplifier frequency response

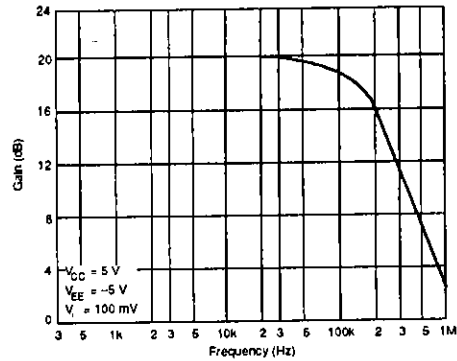

Focus error amplifier frequency response

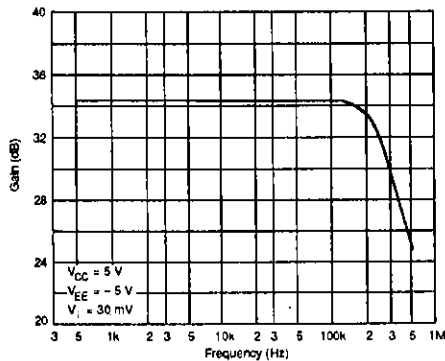

Overall open-loop frequency response

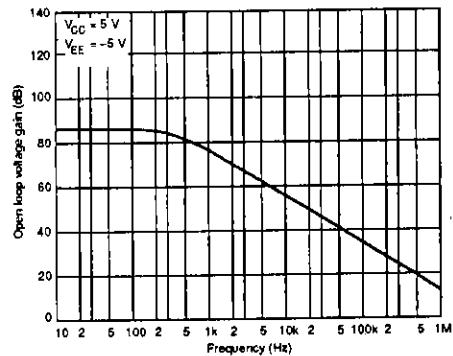

Tracking error preamplifier frequency response

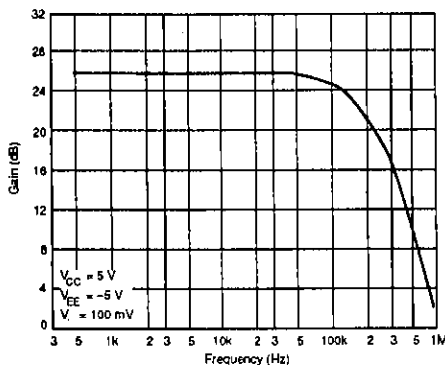

FUNCTIONAL DESCRIPTION

RF Summing Amplifier

The combined current from photodiodes A and C, (A + C), is input on FIV1, and the combined current from B and D, (B + D), on FIV2. These signals are current-to-voltage converted and then input to the RF summing amplifier as shown in figures 1 and 2. The summing amplifier output, (A + C) + (B + D) on RFSM, is filtered externally to generate the HF (eye pattern) signal. Note that the output voltage on RFSM should be between 1 and 2  $V_{pp}$ .

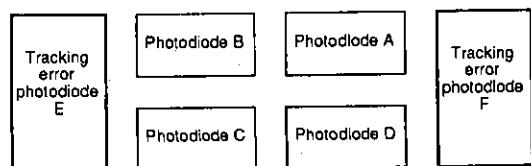

Figure 1. Photodiodes

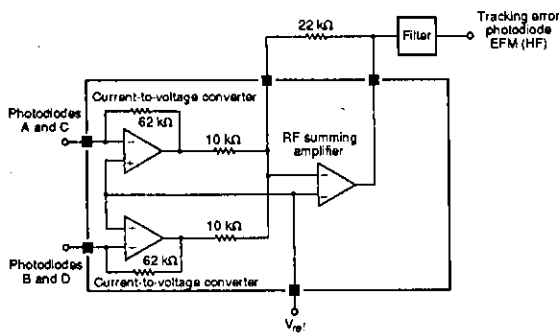

Figure 2. RF summing amplifier

**Focusing**

Focusing is started when pin FST of the digital signal processor, the LC7860K for example, goes LOW and the objective lens is lowered. The lens is then raised gradually while FOCS is HIGH. When the lens reaches the in-focus position and FEAO is less than  $VR3 - 0.5$  V, FZD goes LOW. The FOCS signal is reset and FSW is open circuited. The focusing servocontroller then turns ON and if DRF is HIGH, focusing servocontroller operation continues.

**Focusing Servocontroller**

Focusing is controlled by monitoring the difference in luminance received by the pickup photodiodes.

**Focus error amplifier**

The signals from the photodiode current-to-voltage converters are subtracted to provide a measure of the differential, or focus, error. The focus error amplifier output, is  $(B + D) - (A + C)$  on FEAO. A typical output is shown in figure 3.

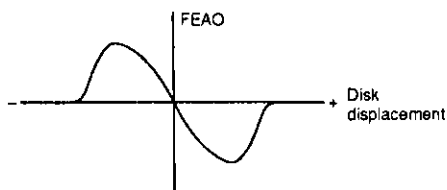

Figure 3. Focus error amplifier output

**Focus detect RF comparator**

The RF comparator output on DRF goes HIGH when the peak RF summing amplifier input signal,  $(A + C) + (B + D)$ , exceeds the reference voltage,  $VR1$ , as shown in figure 4.

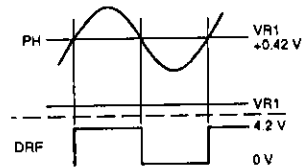

Figure 4. RF detector output

**Focus zero-crossing comparator**

This detects the zero-crossing points of the focus error amplifier output. The zero-crossing comparator output on FZD goes HIGH when the focus error amplifier exceeds  $(VR3 - 0.5$  V) as shown in figure 5.

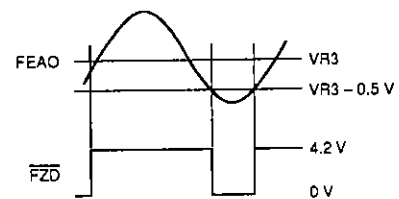

Figure 5. Zero-crossing comparator output

**Focus switch**

The focus switch is used to hold the focus lens at the reference position during startup. When FOCS goes HIGH, FSW is connected to  $VR3$ , temporarily overriding the focus error amplifier output as shown in figure 6.

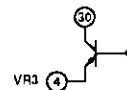

Figure 6. Focus switch

**Tracking Servocontroller**

The tracking servocontroller is applied to three beams—the main beam and two sub-beams—to maintain tracking accuracy as shown in figure 7.

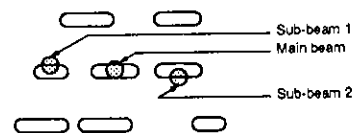

Figure 7. Tracking beams

The reflected light from sub-beams 1 and 2 is received by photodiodes E and F, respectively. When the tracking drifts laterally, the reflected light received from each beam is different. This differential is used to realign tracking.

**Tracking error amplifier**

The current from pickup photodiode E is input on E (pin 47), and from photodiode F, on F (pin 48). These signals are current-to-voltage converted and then input

to the tracking error amplifier. The tracking error amplifier is a difference amplifier and its output, (F - E) on TEAO, is shown in figure 8.

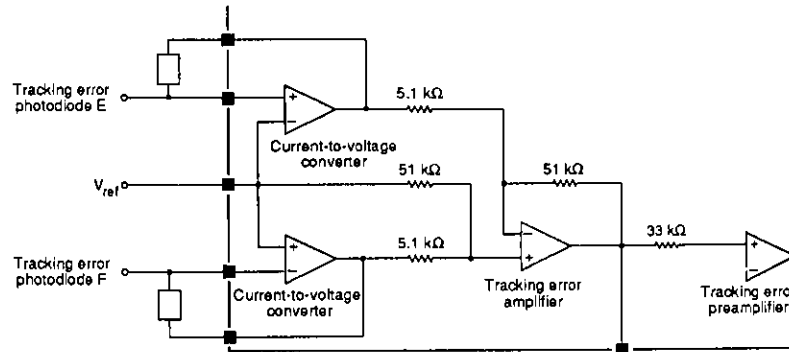

Figure 8. Tracking error amplifier

**Tracking error preamplifier**

This amplifier compensates the gain and phase responses of the tracking servocontroller loop.

**Jump pulse amplifier**

This amplifier is used to jump tracks when selecting a required track or when braking.

**High-frequency level comparator**

The comparator output on HFL is used to detect the off-track condition. It is also used with the output on TES to provide the digital signal processor, the LC7860K for example, with brake timing control information as shown in figures 9 and 10.

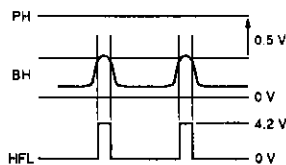

Figure 9. High-frequency level comparator signal

**Tracking error slice comparator**

This detects the zero crossing of the tracking error signal to provide the digital signal processor, the LC7860K for example, with the number of tracks crossed while in jump mode or the brake timing control information using the phase difference between HFL and TES as shown in figure 10.

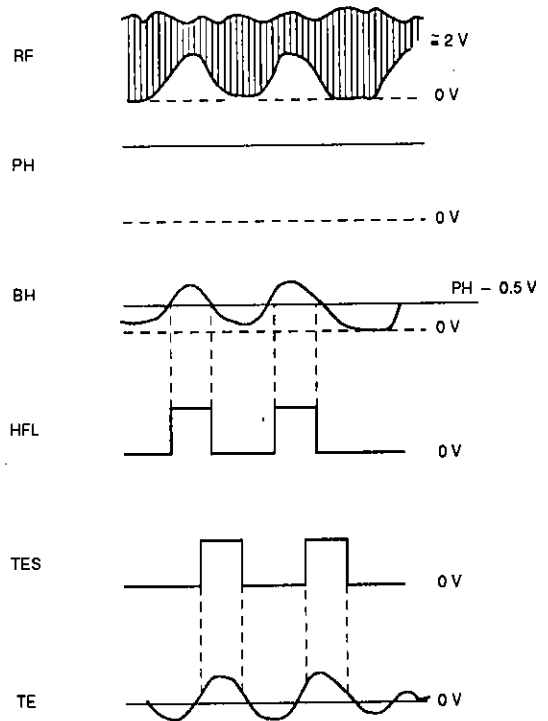

Figure 10. Tracking error signals

The tracking error slice comparator has a Schmitt-trigger input to eliminate incorrect operation caused by noise.

**Servocontroller OFF switch**

When TOFF goes HIGH, TOFS is connected to VR3 turning OFF the tracking servocontroller as shown in figure 11.

**Servocontroller gain control switch**

When TGL goes HIGH, THDS is connected to VR3 through a 5.6 kΩ resistor reducing the servocontroller loop gain as shown in figure 11.

**Servocontroller hold control switch**

When THLD goes HIGH, THDS is connected to VR3 holding the servocontroller output voltage as shown in figure 11.

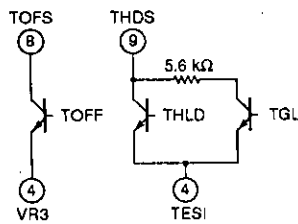

Figure 11. Control switches

**Voltage-controlled-oscillator Control Amplifier**

The output signal from the PDO pin of the digital signal processor, the LC7860K for example, is input to the amplifier on PDO. The amplifier output voltage on VCOC controls the oscillator in the phase-locked loop to maintain synchronicity with the EFM signal (channel bit rate of 4.3218 Mb/s).

**Slice Level Control Amplifier**

This maintains the duty ratio of the HF (eye pattern) signal constant at 50%. When the HF signal is input to the digital signal processor, the LC7860K for example, on pin EFMIN, an amplitude limited, in-phase signal is input on EFMO, and an amplitude limited, opposite-phase signal, on  $\overline{\text{EFMO}}$ . The slice level control amplifier output on SLCO is fed back to EFMIN which automatically maintains the duty ratio at 50%.

**Laser-diode Switch**

The current drive for the pickup laser on LDD is switched ON when LDSW is LOW, and OFF, when HIGH.

**Reference Voltages**

The voltage source,  $V_{ref}$ , generates the reference voltages required for single- and dual-supply voltage operation. These voltages are  $V_{R2} = V_{R3} = 2.5 \text{ V}$  and  $V_{R1} = 1.5 \text{ V}$  for single supply operation, and  $V_{R1} = V_{R2} = V_{R3} = 0 \text{ V}$  for dual supply operation.

TYPICAL APPLICATIONS

Single-ended Power Supply Operation

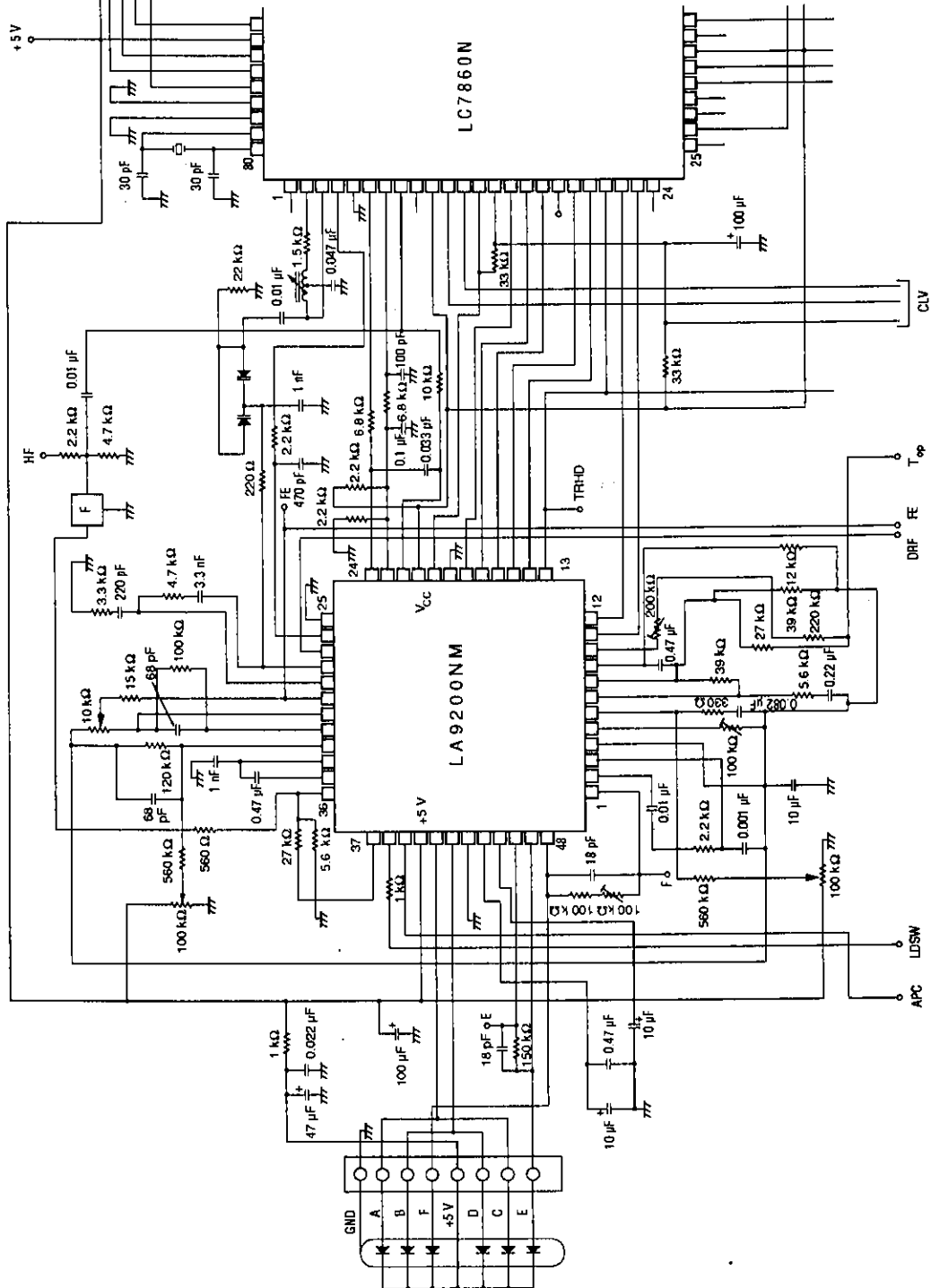

# LA9200NM,9201M

## Dual Power Supply Operation

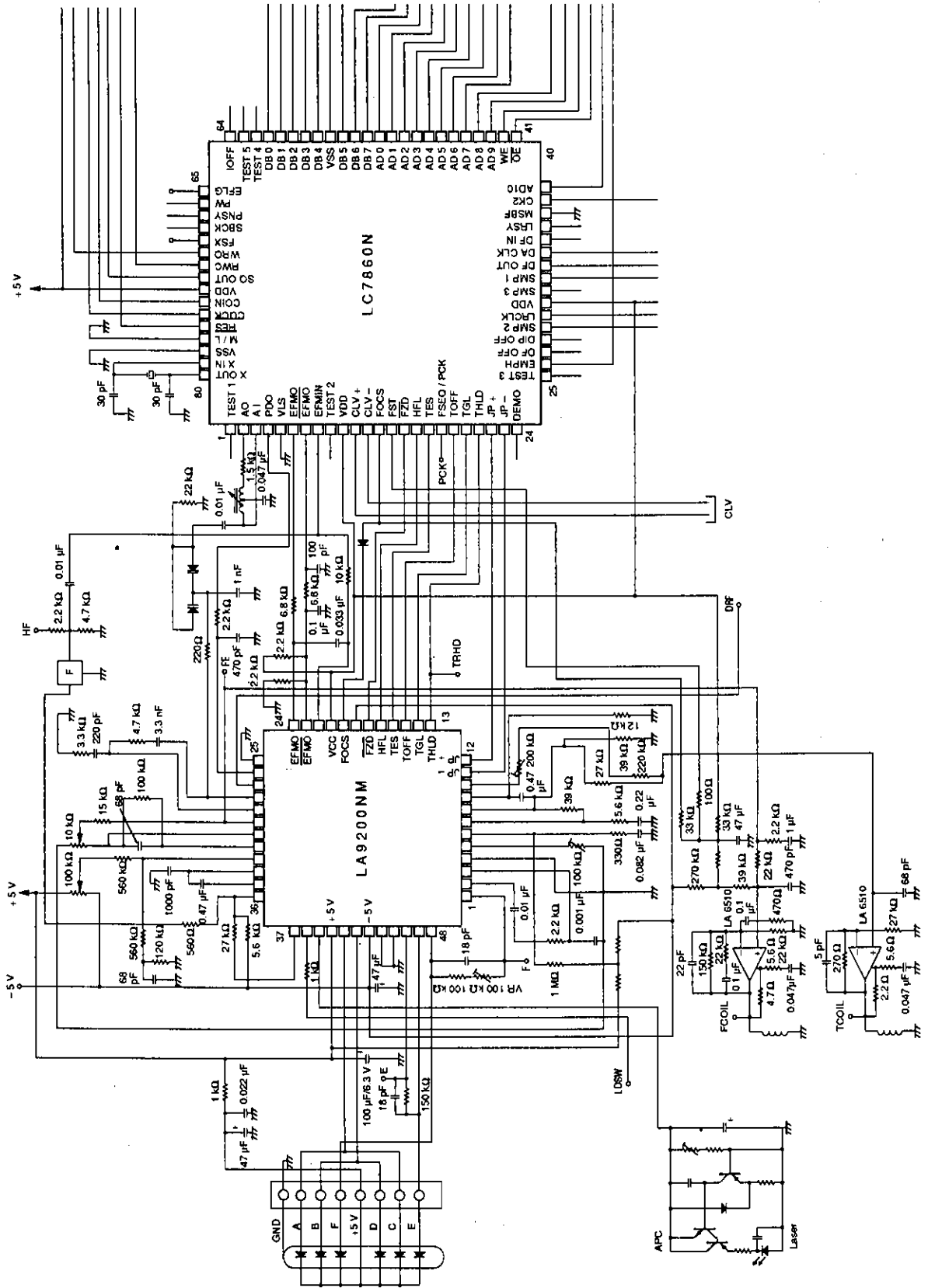



Compact Disc Player

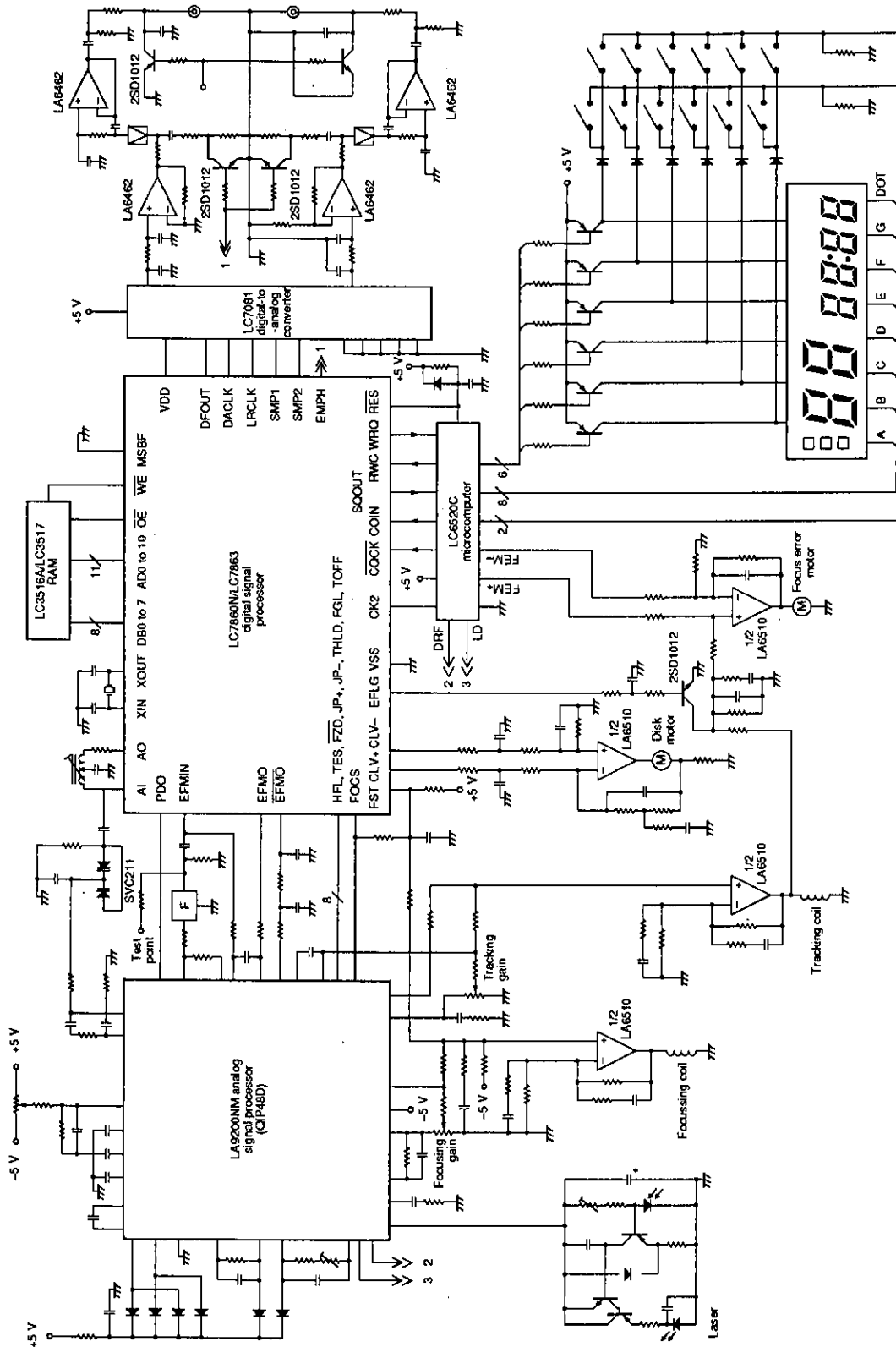

- No products described or contained herein are intended for use in surgical implants, life-support systems, aerospace equipment, nuclear power control systems, vehicles, disaster/crime-prevention equipment and the like, the failure of which may directly or indirectly cause injury, death or property loss.
- Anyone purchasing any products described or contained herein for an above-mentioned use shall:
  - ① Accept full responsibility and indemnify and defend SANYO ELECTRIC CO., LTD., its affiliates, subsidiaries and distributors and all their officers and employees, jointly and severally, against any and all claims and litigation and all damages, cost and expenses associated with such use:
  - ② Not impose any responsibility for any fault or negligence which may be cited in any such claim or litigation on SANYO ELECTRIC CO., LTD., its affiliates, subsidiaries and distributors or any of their officers and employees jointly or severally.
- Information (including circuit diagrams and circuit parameters) herein is for example only; it is not guaranteed for volume production. SANYO believes information herein is accurate and reliable, but no guarantees are made or implied regarding its use or any infringements of intellectual property rights or other rights of third parties.