

Miniature Panel Mount Optical Encoder

Technical Data

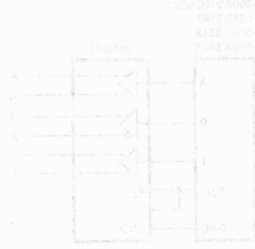
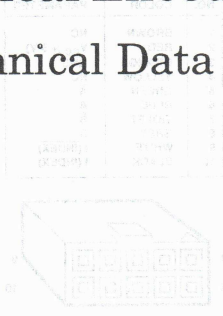

HRPG Series

Features

- **Miniature Size**
- **Smooth Turning and Detented Options**
- **Multiple Mounting Bracket Options**
- **Uses Optical Reflective Technology**
- **Quadrature Digital Output**
- **Small Footprint for Versatile Mounting**
- **TTL Compatible**

Description

The HRPG series is a family of miniature panel mount optical encoders, also known as Rotary Pulse Generators (RPG) and digital potentiometers. The HRPG is designed to be mounted on a front panel and used as a rotary, data-entry device. The HRPG is very flexible for numerous applications due to the many configuration options available. These options include detents or smooth, multiple terminations, versatile mounting capabilities, and different shaft configurations.

The HRPG uses optical reflective technology providing accuracy and reliability to the encoder. An LED emits a beam of light onto the specular codewheel surface. When the light strikes the surface, it projects the image of the codewheel back on the photo-detector, causing the output to change. The entire detector circuit is on one IC, thus the part is less sensitive to temperature and other environmental variations.

Applications

Typical applications for the Rotary Pulse Generator include front panel instruments, audio/visual boards, and other devices requiring digital output from a turning knob.

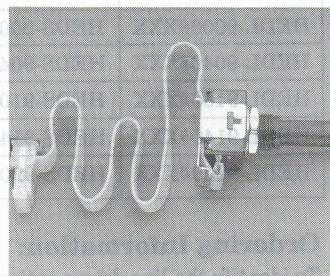
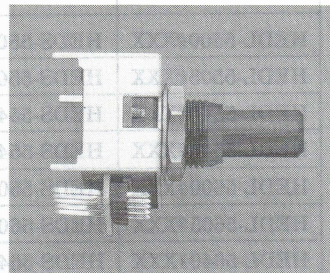
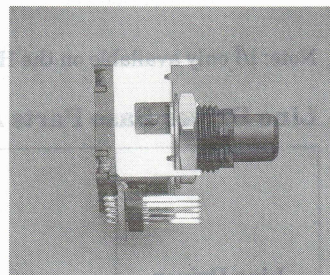

Absolute Maximum Ratings

Parameter	Symbol	Min.	Max.	Units	Notes
Storage Temperature	T_s	-40	+85	°C	
Operating Temperature	T_A	0	+70	°C	
Vibration			20	g	20 Hz to 2 kHz
Supply Voltage	V_{CC}	-0.5	7	V	
Output Voltage	V_O	-0.5	V_{CC}	V	
Output Current Per Channel	I_O	-1	5	mA	
Shaft Load – Axial			4.0	N	10^6 Revolutions
Shaft Load – Radial			0.1	Nm	10^6 Revolutions
Revolution Life		10^6		Rev	At Maximum Loads

Recommended Operating Conditions

Parameter	Symbol	Min.	Max.	Units	Notes
Temperature	T	0	+70	°C	Non Condensing Atmosphere
Supply Voltage	V_{CC}	4.5	5.5	V	Ripple < 100 mV _{P-P}
Rotation Speed – Detented			200	RPM	
– Smooth			300	RPM	

Electrical Characteristics Over Recommended Operating Range

Parameter	Symbol	Min.	Max.	Units	Notes
Supply Current	I_{CC}		40	mA	
High Level Output Voltage	V_{OH}	2.4		V	$I_{OH} = -40 \mu A$ Max.
Low Level Output Voltage	V_{OL}		0.4	V	$I_{OL} = 3.2$ mA

Output Waveforms

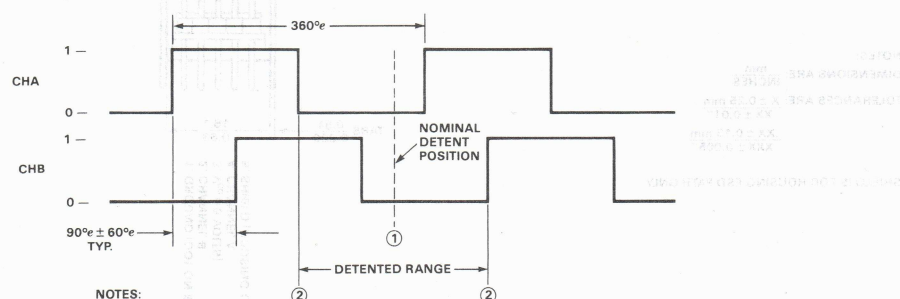

- NOTES:
 $360^\circ = \frac{360^\circ \text{ MECH.}}{\text{CPR}}$
 CHANNEL A LEADS CHANNEL B FOR CLOCKWISE ROTATION
 CHANNEL B LEADS CHANNEL A FOR COUNTERCLOCKWISE ROTATION
 1. FOR HRPG-ADXX #XXX THE NOMINAL DETENT POSITION IS CENTERED AROUND LOW-LOW STATE
 (CHA = 0, CHB = 0).
 2. DETENT POSITION WILL LIE WITHIN THESE BOUNDARIES, NEVER IN HIGH-HIGH STATE
 (CHA = 1, CHB = 1).

Mechanical Configurations

Termination Options Option R - Pins Rear with Bracket HRPG-AXXX#XXR

SUGGESTED CONFIGURATION

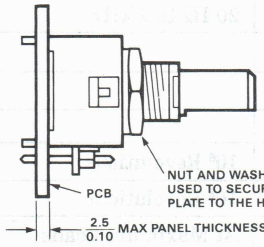

PCB MOUNTING DIMENSIONS

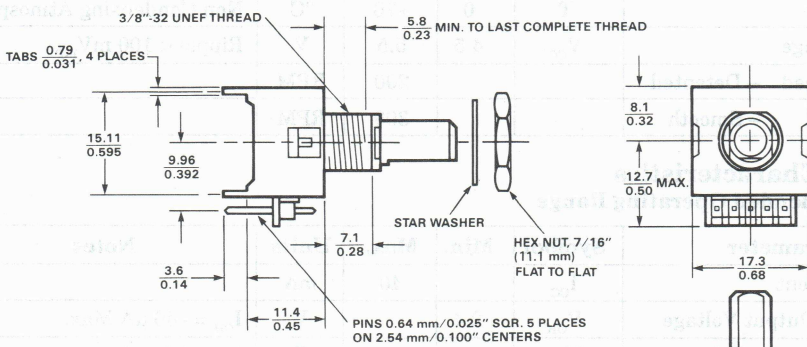
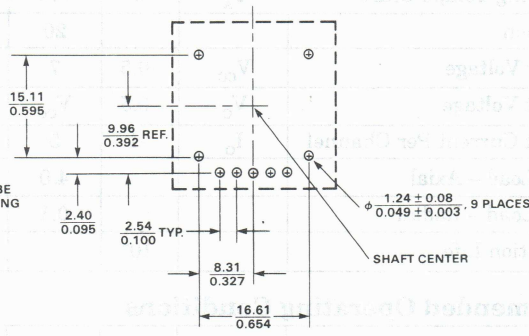

NOTES:
DIMENSIONS ARE: $\frac{mm}{INCHES}$
TOLERANCES ARE: $X \pm 0.25 mm$
 $.XX \pm 0.01''$
 $.XX \pm 0.13 mm$
 $.XXX \pm 0.005''$

SHIELD IS FOR HOUSING ESD PATH ONLY

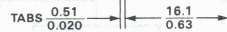

1. GROUND (DOT ON BOTTOM)
2. CHANNEL B
3. V_{CC} (+5 VOLTS)
4. CHANNEL A
5. SHIELD (HOUSING GROUND)

Option F - Pins Front with Bracket
HRPG-AXXX#XXF

SUGGESTED CONFIGURATION

PCB MOUNTING DIMENSIONS

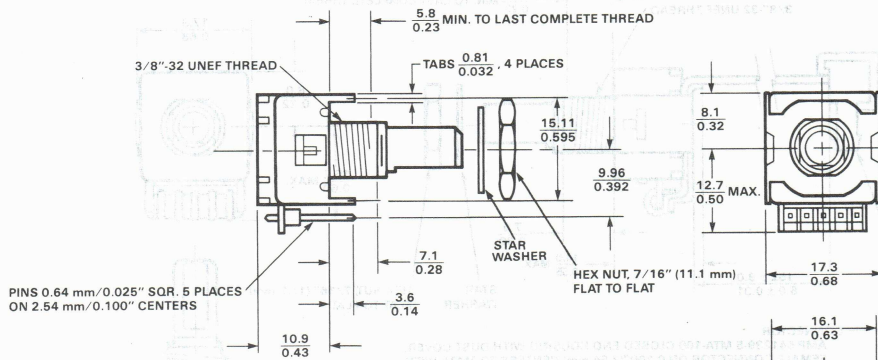
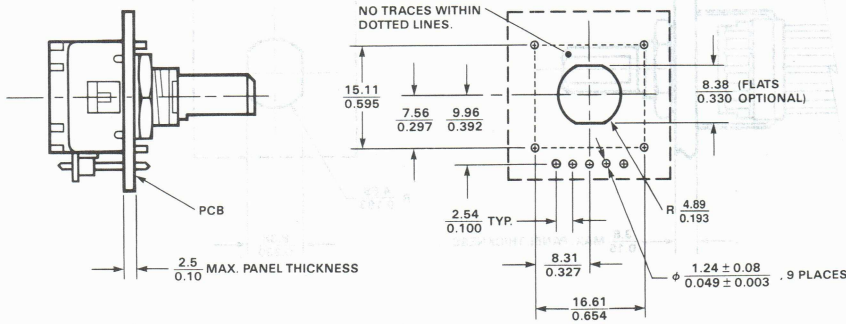

NOTES:
DIMENSIONS ARE: mm
INCHES
TOLERANCES ARE: X ± 0.25 mm
.XX ± 0.01"
.XX ± 0.13 mm
.XXX ± 0.005"

SHIELD IS FOR HOUSING ESD PATH ONLY

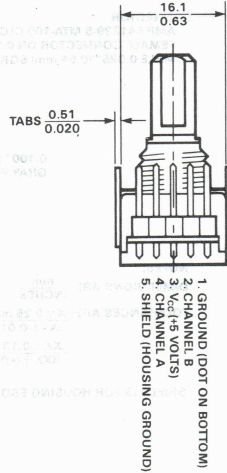

Option C - Cable Connector with Strain Relief
HRPG-AXXX#XXC

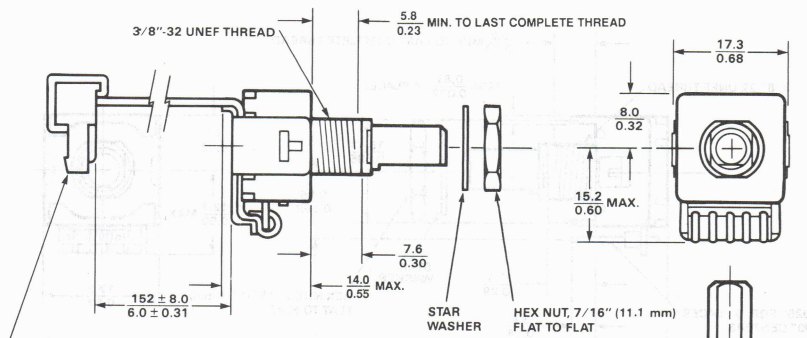
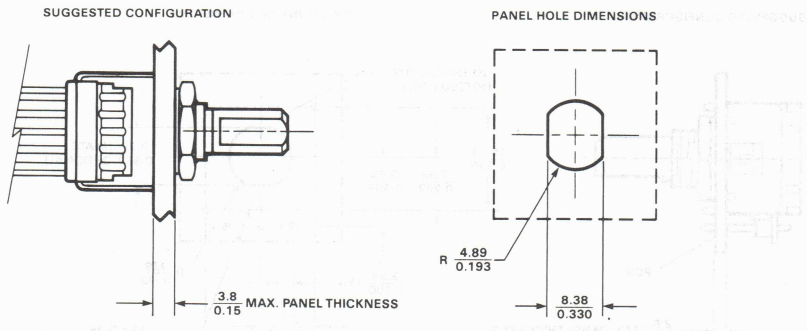

CONNECTOR
 AMP 641239-5 MTA-100 CLOSED END HOUSING WITH DUST COVER,
 FEMALE CONNECTOR ON 0.100" (2.54 mm) CENTERS TO MATE WITH
 MALE 0.025" (0.54 mm) SQR. POSTS, 0.28 ± 0.04 (7.11 ± 1.00 mm) LONG.

0.100" (2.54 mm) CENTERS, ROUND CONDUCTOR FLAT CABLE
 GRAY PVC INSULATION

NOTES:
 DIMENSIONS ARE: mm
 INCHES
 TOLERANCES ARE: X ± 0.25 mm
 .XX ± 0.01"
 .XX ± 0.13 mm
 .XXX ± 0.005"

SHIELD IS FOR HOUSING ESD PATH ONLY

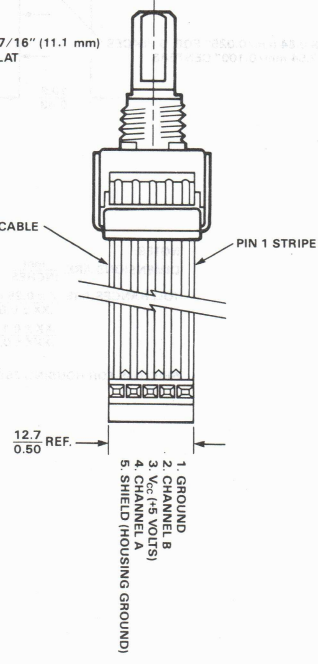

Shaft Configurations





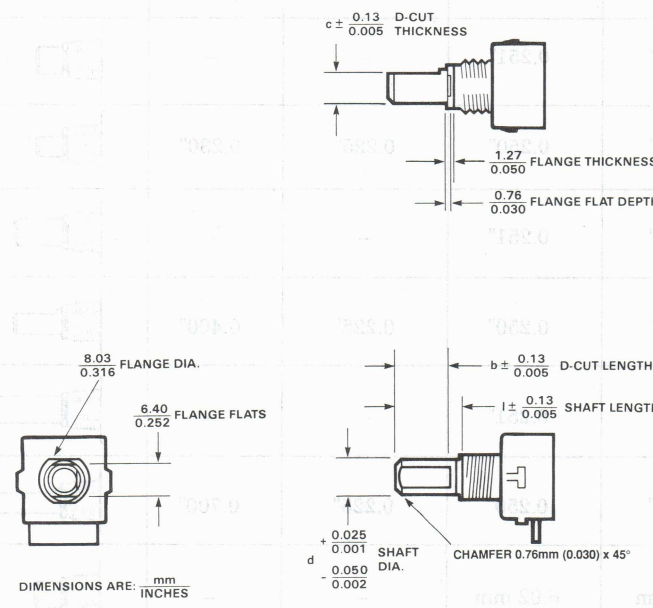

Shaft Dimensions (D-cut shown also)

Shaft Options Available

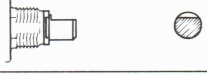
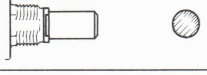
Option #	Shaft Length (l)	Shaft Diameter (d)	D-Cut Thickness (c)	D-Cut Length (b)	Flange Diameter	Flange Flats
11	0.30"	0.250"	0.030"	0.250"	0.700"	0.250"
12	0.30"	0.250"	0.030"	0.250"	0.700"	0.250"
13	0.30"	0.250"	0.030"	0.250"	0.700"	0.250"
14	0.30"	0.250"	0.030"	0.250"	0.700"	0.250"
15	0.30"	0.250"	0.030"	0.250"	0.700"	0.250"
16	0.30"	0.250"	0.030"	0.250"	0.700"	0.250"
17	0.30"	0.250"	0.030"	0.250"	0.700"	0.250"
18	0.30"	0.250"	0.030"	0.250"	0.700"	0.250"
19	0.30"	0.250"	0.030"	0.250"	0.700"	0.250"
20	0.30"	0.250"	0.030"	0.250"	0.700"	0.250"
21	0.30"	0.250"	0.030"	0.250"	0.700"	0.250"
22	0.30"	0.250"	0.030"	0.250"	0.700"	0.250"
23	0.30"	0.250"	0.030"	0.250"	0.700"	0.250"
24	0.30"	0.250"	0.030"	0.250"	0.700"	0.250"
25	0.30"	0.250"	0.030"	0.250"	0.700"	0.250"
26	0.30"	0.250"	0.030"	0.250"	0.700"	0.250"
27	0.30"	0.250"	0.030"	0.250"	0.700"	0.250"
28	0.30"	0.250"	0.030"	0.250"	0.700"	0.250"

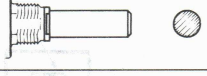
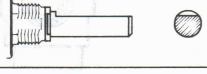

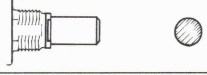
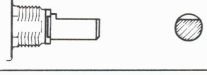
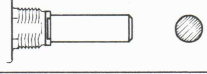
Shaft Options Available

Option #	Shaft Length (l)	Shaft Diameter (d)	D-Cut Thickness (c)	D-Cut Length (b)	Sketch (not to scale)
11	0.30"	0.251"	-	-	
13	0.30"	0.250"	0.225"	0.230"	
14	0.50"	0.251"	-	-	
16	0.50"	0.250"	0.225"	0.400"	
17	0.80"	0.251"	-	-	
19	0.80"	0.250"	0.225"	0.700"	
51	7.6 mm	6.02 mm	-	-	
53	7.6 mm	6.00 mm	5.33 mm	5.84 mm	
54	12.7 mm	6.02 mm	-	-	
56	12.7 mm	6.00 mm	5.33 mm	10.16 mm	
57	20.32 mm	6.02 mm	-	-	
59	20.32 mm	6.00 mm	5.33 mm	17.78 mm	

Typical Interface

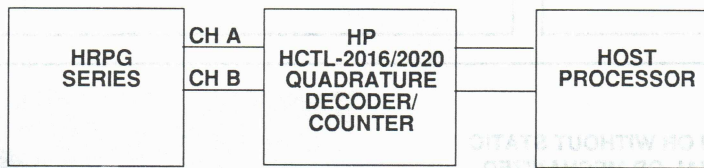

Ordering Information

HRPG - A [] [] [] # [] [] []

Shaft Feel / Resolution
 S16 – Smooth 16CPR
 D16 – Detented 16CPR*
 S32 – Smooth 32CPR
 D32 – Detented 32CPR*
 S64 – Smooth 64CPR
 SCA – Smooth 120CPR

Mechanical Configuration
 11 – 0.3" long, 0.25" dia.
 13 – 0.3" long, 0.25" dia. D-cut
 14 – 0.5" long, 0.25" dia.
 16 – 0.5" long, 0.25" dia. D-cut
 17 – 0.8" long, 0.25" dia.
 19 – 0.8" long, 0.25" dia. D-cut
 51 – 7.6 mm long, 6 mm dia.
 53 – 7.6 mm long, 6 mm dia. D-cut
 54 – 12.7 mm long, 6 mm dia.
 56 – 12.7 mm long, 6 mm dia. D-cut
 57 – 20.3 mm long, 6 mm dia.
 59 – 20.3 mm long, 6 mm dia. D-cut

Termination
 F – Pins Front with Bracket
 R – Pins Rear with Bracket
 C – Cable Connector with Strain Relief

*Note: When ordering detented versions, a D-cut shaft is recommended.