

Switch 4 sources to 4 displays, independently

Optional Accessories



RMT IR Extender



DVI Cables



CAT5 to Serial

4x4 HDTV Matrix

Connect and access any four sources from up to four displays

4 Sources + 4 Displays = An Easily Integrated HDTV Matrix System

The 4x4 HDTV Matrix routes high definition video in multiple resolutions up to 1080p from any of the four HDTV sources to the displays. Four outputs gives you the choice of sending high definition video signals up to four displays. Any four to any four matrix switching allows for maximum versatility for integrated systems. The 4x4 HDTV Switcher eliminates the need to disconnect and reconnect sources to a display equipped with one input. It works with HD-DVD players, TiVo systems, HT PCs, and satellite set top boxes that connect to a DVI display. Every source is accessible at all times by any display by selecting it with an IR remote.

Fully HDCP Compliant

HDCP (high bandwidth digital content protection) is a standard encoded into the video signal to prevent it from being pirated. If a source device is HDCP coded and is connected to a display or projector without the proper decoding mechanism, the picture is relegated to "snow" or in some cases, very low (480P) resolutions of the images. In order to see high resolution digital video with HDCP compliance, both the source, the display and anything in between must be equipped with HDMI/DVI connections that can enable HDCP decoding, such as the 4x4 HDTV Matrix.

How It Works

You simply connect the sources to the Matrix's inputs. Then connect four displays to the Matrix's outputs. Once the sources, the matrix and the displays are powered and connected, you simply select which sources you want view on which displays using the IR remote.

Note: DVI, HDCP & HDMI Defined

Features:

- Switch easily between any four HDTV sources
- Distributes any of the four inputs to any of the four HDTV output displays
- Maintains high resolution video - beautiful, sharp HDTV resolutions up to 1080p, 2k, and computer resolutions up to 1920 x 1200 are easily achieved
- Discrete IR remote (included)
- Serial RS-232 remote port
- Rack ears included
- HDCP compliant

Specifications:

- Video Amplifier Bandwidth: 165 MHz
- Input Video Signal: 1.2 Volts p-p
- Input DDC Signal: 5 Volts p-p (TTL)
- Single Link Range: 1080p/1920 x 1200
- DVI Connector: DVI-I 29 Pin Female (digital only)
- Remote Control Port: RS232 female, mini-stereo
- Power Supply: 24V DC
- Power Consumption: 60 Watts (max)
- Dimensions: 17"W x 1.75"H x 5.875"D
- Shipping Weight: 10 lbs.

Package Includes:

- 4x4 HDTV Matrix
- RMT-16IR Remote Control
- Four 6 foot DVI cables
- 24V DC Power Supply
- User's Manual
- Rack Ears



EXT-HDTV-444N



4x4 HDTV
Matrix
USER MANUAL

www.gefen.com

ASKING FOR ASSISTANCE

Technical Support:

Telephone (818) 772-9100
(800) 545-6900

Fax (818) 772-9100

Technical Support Hours:

8:00 AM to 5:00 PM Monday through Friday.

Write To:

Gefen Inc.
c/o Customer Service
20600 Nordhoff Street
Chatsworth CA 91311

www.gefen.com
support@gefen.com

Notice

Gefen Inc. reserves the right to make changes in the hardware, packaging and any accompanying documentation without prior written notice.

The 4x4 HDTV Matrix is a trademark of Gefen Inc.

TABLE OF CONTENTS

- 1** Introduction / Operation Notes
- 2** Features
- 3** Panel Layout
- 4** Using the 4x4 HDTV Matrix
- 5** RMT16-IR Installation
- 6** Dip Switch Guidelines
- 7** IR Codes
- 8** RS-232 Interface
- 9** 4x4 HDTV Matrix Rack Mount Diagram
- 10** Specifications
- 11** Terminology
- 12** Warranty

INTRODUCTION

Thank you for purchasing the 4x4 HDTV Matrix.

The 4x4 HDTV Matrix switches four HDTV sources to any four DVI displays.

The 4x4 HDTV Matrix switcher has four DVI inputs and four DVI outputs. Matrix input #1 and the DVI port of source #1 connects using a male to male DVI cable. The DVI port of source #2 connects to DVI input #2. The DVI port of source #3 connects to DVI input #3. The DVI port of source #4 connects to DVI input #4. There are four (4) DVI outputs connecting to four (4) different displays.

Note: The switching is done by using either the the RMT-16-IR remote control or through the RS232 port. The 4x4 HDTV Matrix is rack mountable. Any HDTV with HDMI inputs can be connected to the DVI outputs of the matrix by using a DVI to HDMI adapter or cable.

OPERATION NOTES

READ THESE NOTES BEFORE INSTALLING OR OPERATING THE 4X4 HDTV MATRIX

- You should connect all the cables and power supply prior to connecting power to the HDTV sources and 4x4 HDTV Matrix.
- When powering the sources, the display needs to point to the source input.
- The 4x4 HDTV Matrix is housed in a metal box for better RF shielding.
- The 4x4 HDTV Matrix works with all DVI and HDMI displays.
- The 4x4 HDTV Matrix only supports VIDEO signals.
- The 4x4 HDTV Matrix is fully HDCP compliant.

FEATURES

Features

- Allows any DVI/HDMI display to view any source at any time
- Allows any source to be displayed on multiple displays at the same time
- Maintains resolutions up to 1080p, 2K, and 1920x1200
- Maintains highest DVI single link video resolution
- Supports HDCP compliant devices
- DVI or DVI to HDMI cables are used to connect the inputs and the matrix output
- Each display's inputs can be switched with the IR remote control or through RS232

Includes:

- (1) 4x4 HDTV Matrix
- (4) DVI 6ft Male to Male Cables
- (1) 24VDC Power Supply
- (1) User Manual
- (1) RMT-16IR Remote Control
- (1) Rack Ears

Front Panel



- Display 1 LED Indicator
- Display 2 LED Indicator
- Display 3 LED Indicator
- Display 4 LED Indicator
- IR Sensor
- IR Extender Eye Port
- Power Indicator

Back Panel



- RS232 Controller Port
- DVI Inputs
- DVI Outputs
- Connects to 24VDC Power Supply

USING THE 4X4 HDTV MATRIX

- 1 Connect all the sources to the HDMI inputs on the 4x4 HDTV Matrix, using the supplied cables.
- 2 Connect the HDMI/DVI displays to the outputs on the 4x4 HDTV Matrix.
- 3 Connect the 24VDC powersupply to the 4x4 HDTV Matrix
- 4 Controlling the 4x4 HDTV Matrix using the RMT16-IR:

Pressing Buttons...	Switches...
1-4	Display 1 to view Source 1, 2, 3, or 4
5-8	Display 2 to view Source 1, 2, 3, or 4
9-12	Display 3 to view Source 1, 2, 3, or 4
13-16	Display 4 to view Source 1, 2, 3, or 4

***Note for computers connected to the HDTV Matrix** - When your computer boots up, it looks for an EDID (extended display identification data) from the display to tell it what monitor is connected and what resolution to output. During boot up of the computer you should have ONLY one output selected to one input at a time so that the computer gets the EDID of the display that is selected. If you have multiple outputs selected to one computer, the computer will read the EDID of the last output selected to it. If all your displays are the same, or all displays are capable of running at the same resolution then this step does not matter.

RMT16-IR Installation

1. Remove battery cover from the back of the RMT16-IR remote.
2. Verify that dip switches 1 & 2 are in the down (OFF) position.
3. Insert the battery, hold the battery so that you can see the positive side facing up. The side that is not marked must be facing down.
4. Test the RMT16-IR remote by pressing **ONLY** one button at a time. The indicator light on the remote will flash once each time you press a button. **WARNING:** Do not press multiple buttons simultaneously and do **NOT** press buttons rapidly. These actions will cause the remote to reset and steps 1-4 will have to be repeated.

Note: The RMT16-IR ships with two batteries. One battery is required for operation, the second battery is complimentary.

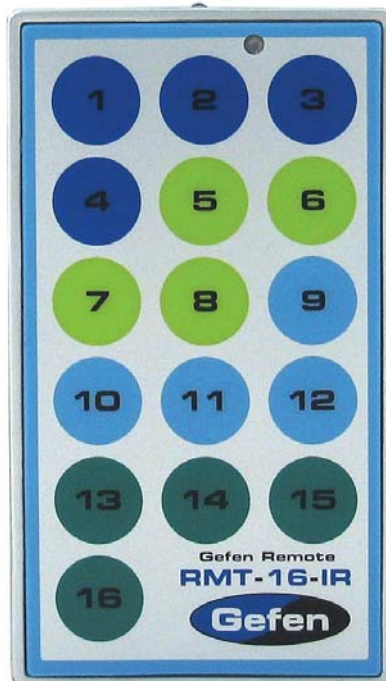

DIP SWITCH GUIDELINES

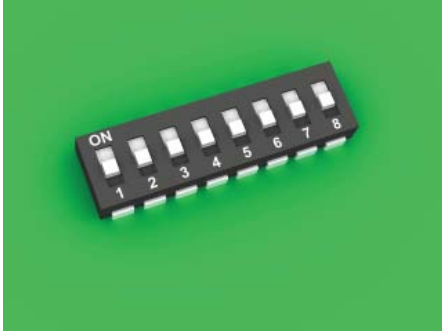

DIP SWITCH EDID GUIDE

Extended display identification data (EDID) is a data structure provided by a display to describe its capabilities to any source that asks for it. The EDID includes manufacturer name, product type, timings supported by the display, display size, luminance data, (for digital displays only) pixel mapping data, supported audio channels and formats. This information is used by the source to cater its output to resolutions and audio formats that are supported by the display.

Additional EDID modes are available and configured using a combination of dip switches 1, 2, and 5. Please refer below for the different EDID modes.

To access the Dip Switches, remove all screws from the bottom and sides of the Gefen unit. Remove the hex screw heads from each side of the RS-232 and DVI ports. Carefully slide the unit apart. The 8 Bank of Dip Switches are located on the main PCB. Once adjustments are complete, slide the unit back together and replace all removed screws.

EDID Mode 0 (Switch 1=OFF Switch2=OFF Switch5=ON)
-EDID is copied from the first HDMI port

EDID Mode 1 (Switch 1=ON Switch2=OFF Switch5=ON)
-Same as Mode 0 and adds basic audio support

EDID Mode 2 (Switch 1=OFF Switch2=ON Switch5=ON)
-Same as Mode 0 and adds full audio support

EDID Mode 3 (Switch 1=ON Switch2=ON Switch5=OFF)
-EDID is generated based on the common video and audio features of all of the connected devices

EDID Mode 4 (Switch 1=OFF Switch2=ON Switch5=OFF)
-Same as Mode 3 and adds basic audio support

EDID Mode 5 (Switch 1=ON Switch2=OFF Switch5=OFF)
-Same as Mode 3 and adds full audio support

EDID Mode 6 (Switch 1=OFF Switch2=OFF Switch5=OFF) **DEFAULT**
-EDID is generated based on the common video features of all of the connected devices and the combined audio features of all of the connected devices

IR CODES

In the event of IR conflicts, please do the following:

1. Remove the battery cover from the back of the RMT16-IR remote.
2. Locate the Dip Switches above the batteries
3. Switch the Dip Switches on the RMT16-IR to any of the combinations pictured below.
4. Dip Switches 1 and 2 in the RMT16-IR correspond with Dip Switches 3 and 4 inside the 4x4 HDTV Matrix respectively. Switch the switches inside the 4x4 HDTV Matrix to match the same Remote Channel as the RMT16-IR. The 4x4 Matrix is now set to a new IR Code.

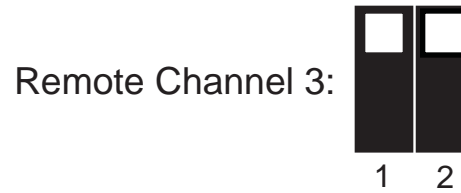
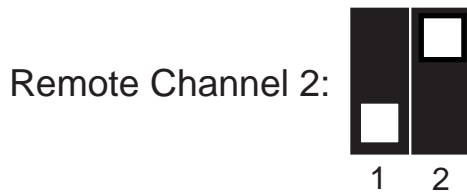
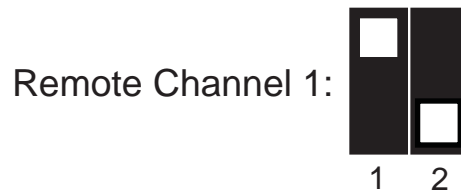
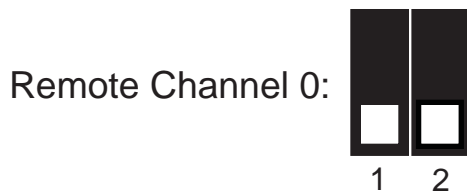

RS-232 INTERFACE

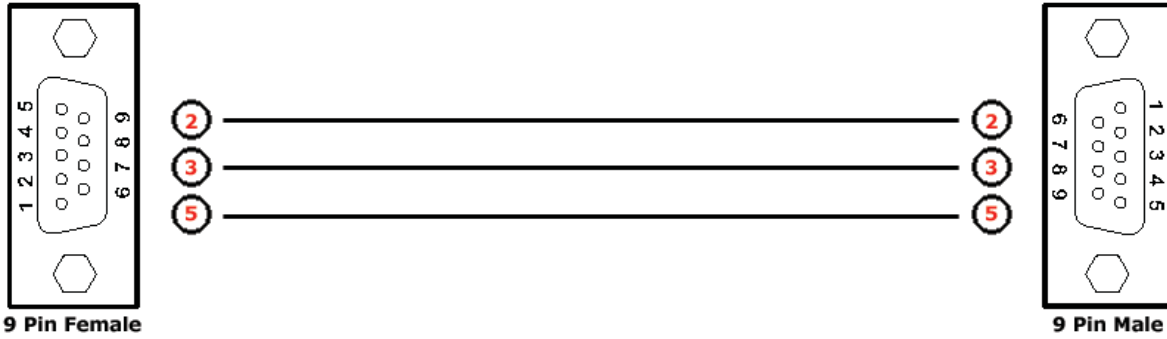

Binary Table

ASCII	Corresponding RMT16-IR Button	Binary	ASCII	Corresponding RMT16-IR Button	Binary
1	1	0011 0001	9	9	0011 1001
2	2	0011 0010	a	10	0110 0001
3	3	0011 0011	b	11	0110 0010
4	4	0011 0100	c	12	0110 0011
5	5	0011 0101	d	13	0110 0100
6	6	0011 0110	e	14	0110 0101
7	7	0011 0111	f	15	0110 0110
8	8	0011 1000	g	16	0110 0111

Additional control of the EDID modes and IR channel are possible using the RS-232 interface. For any of these modes to be successfully written to the EEPROM, all Dip Switches must be in the OFF position.

ASCII	EDID Mode
m0	0
m1	1
m2	2
m3	3
m4	4
m5	5
m6	6

ASCII	Remote Channel
r1	1
r2	2
r3	3
r4	4

OK is printed out on screen when a mode has successfully been changed.

RS232 Settings

Bits per second 19200

Data bits 8

Parity None

Stop bits 1

Flow Control None

4x4 HDTV MATRIX RACK MOUNT DIAGRAM

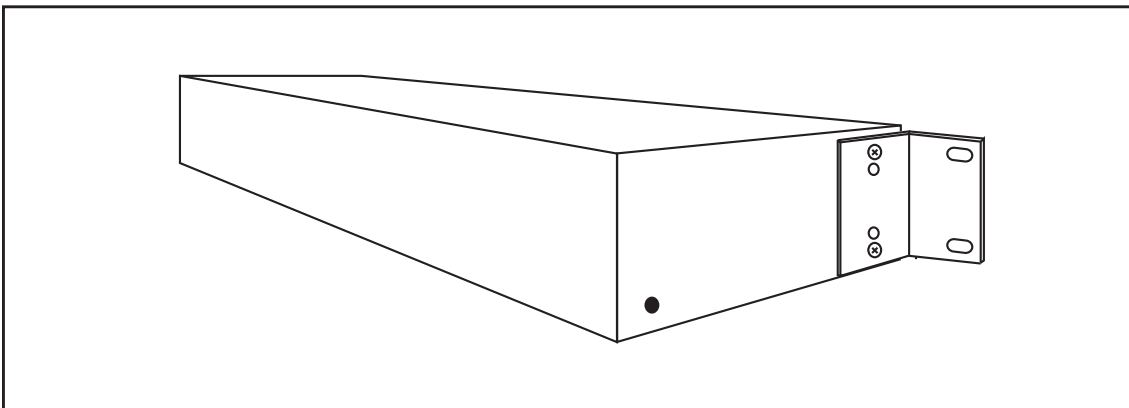
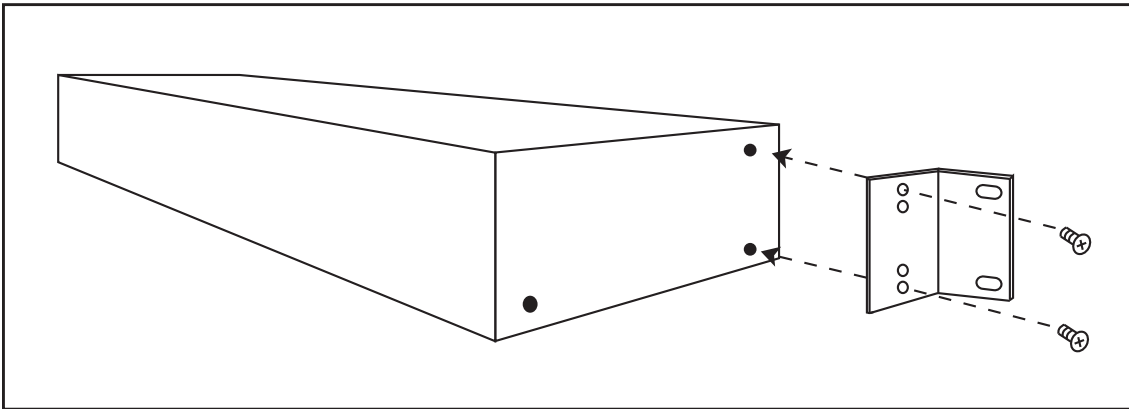
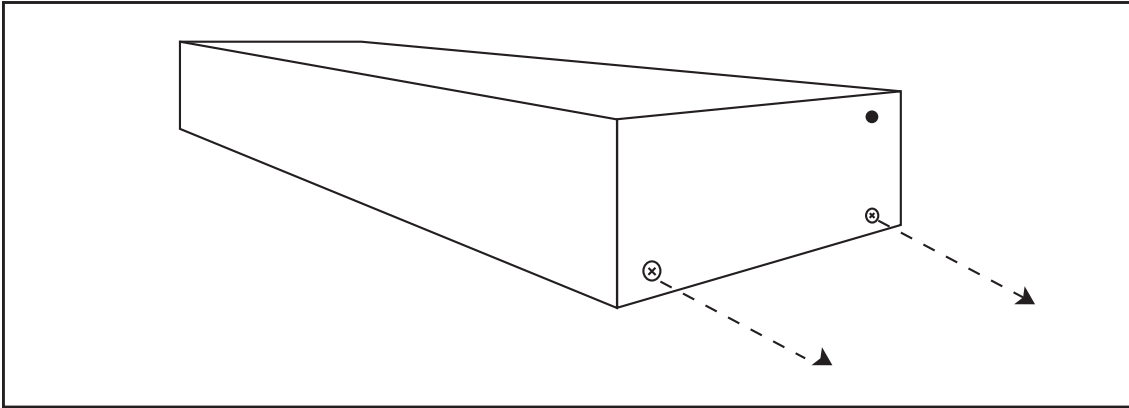
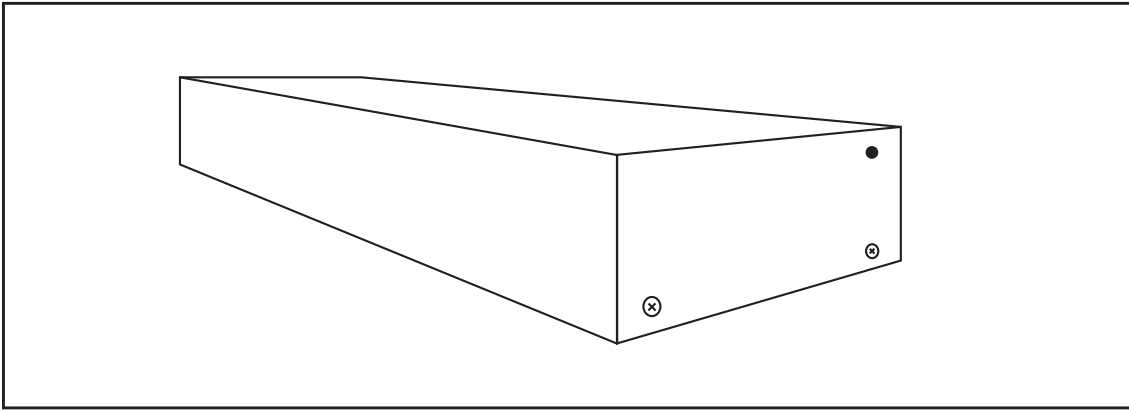

SPECIFICATIONS

Video Amplifier Bandwidth	1.65 Gbps
Input Video Signal	1.2 volts p-p
Input DDC Signal	5 volts p-p (TTL)
Single Link Range	1080p / 1920 x 1200
DVI Input/Output Connector	DVI-D
Remote Control Port	RS-232 Female, Mini-Stereo
Power Consumption	60 watts (max)
Power Supply	24V DC
Dimensions	17" W x 1.75" H x 5.875" D
Shipping Weight	10 lbs.

TERMINOLOGY

DDC

Short form for Display Data Channel. It is a VESA standard for communication between a monitor and a video adapter. Using DDC, a monitor can inform the video card about its properties, such as maximum resolution and color depth. The video card can then use this information to ensure that the user is presented with valid options for configuring the display.

DDWG

Digital Display Working Group DDWG are the creators of the DVI specification.

DVI

Digital Visual Interface. Connection standard developed by Intel for connecting computers to digital monitors such as flat panels and DLP projectors. A consumer electronics version, not necessarily compatible with the PC version, is used as a connection standard for HDTV tuners and displays. Transmits an uncompressed digital signal to the display. The latter version uses HDCP copy protection to prevent unauthorized copying.

HDCP

High-Bandwidth Digital Content Protection. Created by Intel, HDCP is used with HDTV signals over DVI and HDMI connections and on D-Theater D-VHS recordings to prevent unauthorized duplication of copy written material.

HDMI

The High-Definition Multi-media Interface (HDMI) is an industry-supported, uncompressed, all-digital audio/video interface. HDMI provides an interface between any compatible digital audio/video source, such as a set-top box, DVD player, and A/V receiver and a compatible digital audio and/or video monitor, such as a digital television (DTV).

HDTV

High-Definition Television. The high-resolution subset of our DTV system. The ATSC defines HDTV as a 16:9 image with twice the horizontal and vertical resolution of our existing system, accompanied by 5.1 channels of Dolby Digital audio. The CEA defines HDTV as an image with 720 progressive or 1080 interlaced active (top to bottom) scan lines. 1280:720p and 1920:1080i are typically accepted as high-definition scan rates.

RS-232

Recommended Standard 232. This is the de facto standard for communication through PC serial ports. It can refer to cables and ports that support the RS232 standard.

VESA

Video Electronic Standards Association, a consortium of manufacturers formed to establish and maintain industry wide standards for video cards and monitors. VESA was instrumental in the introduction of the Super VGA and Extended VGA video graphics standards with a refresh rate of 70 Hz, minimizing flicker and helping to reduce user eyestrain and fatigue.