

**SPECIFICATION FOR APPROVAL**

**CUSTOMER** :  
**DESCRIPTION** : AXIAL AC FAN  
**DIMENSIONS** : 80X80X25 mm  
**MODEL** : SF23080AT  
**P/N** : 2082HBL  
**APPROVED NO** :  
(AUTHORIZED)  
**APPROVED BY** :



DAWN.	張育真 3/19	CHKD.	品田隆 3/19	APPD.		SPEC. NO.	282227300
						ISSUE DATE	03.18.1996
						EDITION	0
						REVISE DATE	

建準電機工業股份有限公司  
SUNONWEALTH ELECTRIC MACHINE INDUSTRY CO., LTD.  
12FL., 120 CHUNG CHENG 1ST RD., TEL:886-7-7163069(41 LINES)  
KAOHSIUNG, TAIWAN, R. O. C. FAX:886-7-7163086~89

# AXIAL AC FAN

MODEL : SF23080AT

P/N : 2082HBL

## CHARACTERISTICS

- 1. Motor Design : Reliable Shaded-Pole Motor Construction.
- 2. Insulation Resistance : 500 Megohms minimum at 500 VDC.
- 3. Dielectric Strength : 1500 VAC for one minute.
- 4. Motor Protection : Impedence protected.
- 5. Noise Level : Measured in an semi-anechoic chamber with background noise level below 15 dBA. The fan is running in free air with microphone at a distance of one meter from the fan intake.
- 6. Air Performance : Measured by a double chamber. The value are recorded when the fan speed is stabilized at rated voltage.
- 7. Tolerances :  $\pm 15\%$  on rated power and current.

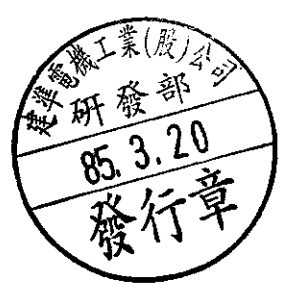

建準電機工業股份有限公司 SUNONWEALTH ELECTRIC MACHINE INDUSTRY CO., LTD.	SPEC. NO.	282227300	REVISE DATE	
	ISSUE DATE	03. 18. 1996	EDITION	0
	PAGE	2 OF 5		

SPECIFICATIONS
----------------

MODEL: SF23080AT

P/N : 2082HBL

1-1. Rated Voltage	:	220/240 VAC 50/60 HZ
1-2. Operating Voltage Range	:	185-245 VAC
1-3. Starting Voltage	:	185 VDC
1-4. Rated Speed	:	2450/2900 RPM $\pm$ 5%
1-5. Air Delivery	:	18/22 CFM
1-6. Static Pressure	:	0.13/0.19 Inch-H <sub>2</sub> O
1-7. Rated Current	:	0.07/0.07 AMP
1-8. Input Power	:	14/13.5 WATTS
1-9. Noise Level	:	30/34.5 dB(A)
1-10. Direction of Rotation	:	Clockwies viewed from front face
1-11. Motor Protection	:	Impredance Protected
1-12. Operating Temperature	:	-20 to +80 Deg.C
1-13. Storage Temperature	:	-40 to +80 Deg.C
1-14. Bearing System	:	Precise ball bearing system
1-15. Weight	:	260 g
1-16. Safety	:	UL/CSA Approvals



建準電機工業股份有限公司 SUNONWEALTH ELECTRIC MACHINE INDUSTRY CO., LTD.	SPEC. NO.	282227300	REVISE DATE	
	ISSUE DATE	03. 18. 1996	EDITION	0
	PAGE	3 OF 5		

MODEL: SF11580AT

P/N : 1082HBL

PERFORMANCE CURVES

STATIC PRESSURE

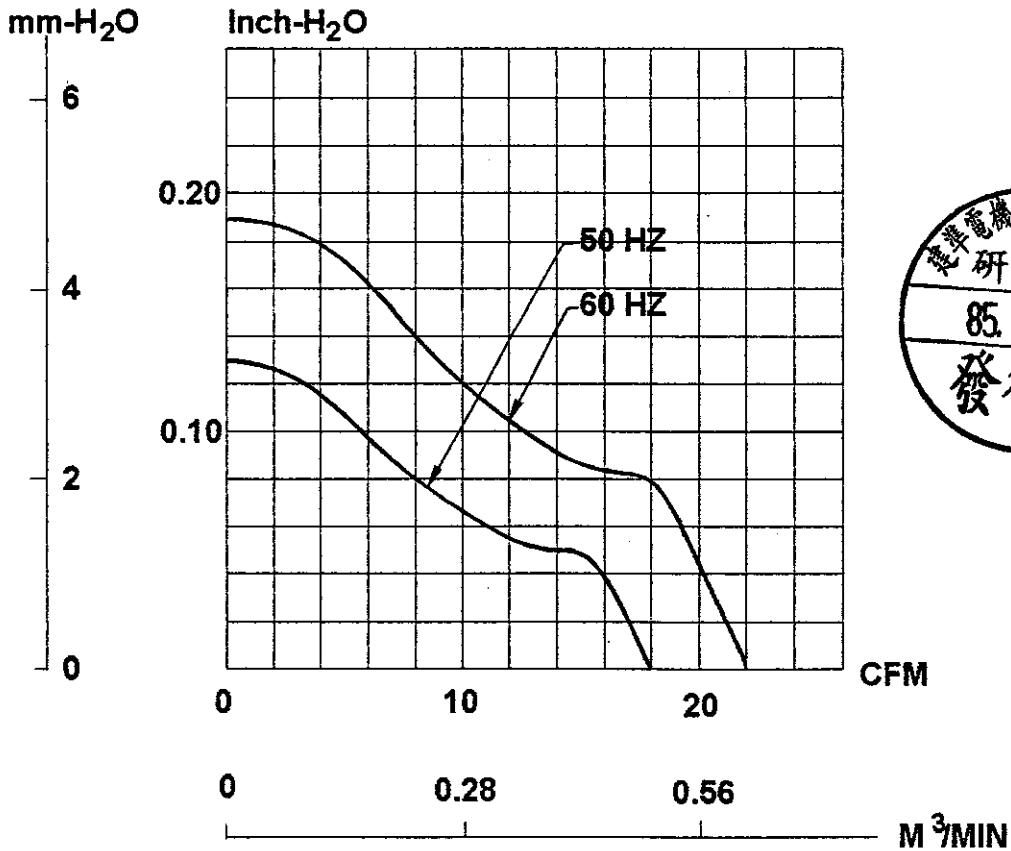

建準電機工業股份有限公司 SUNONWEALTH ELECTRIC MACHINE INDUSTRY CO., LTD.	SPEC. NO.	282227300	REVISE DATE	
	ISSUE DATE	03. 18. 1996	EDITION	0
	PAGE	4 OF 5		

**MATERIAL**

- 2. Material
- 2-1 Frame : Thermoplastic PBT of UL 94V-0
- 2-2. Impeller : Thermoplastic PBT of UL 94V-0
- 2-3. Lead Wire : UL1007,24AWG

**DIMENSIONS**

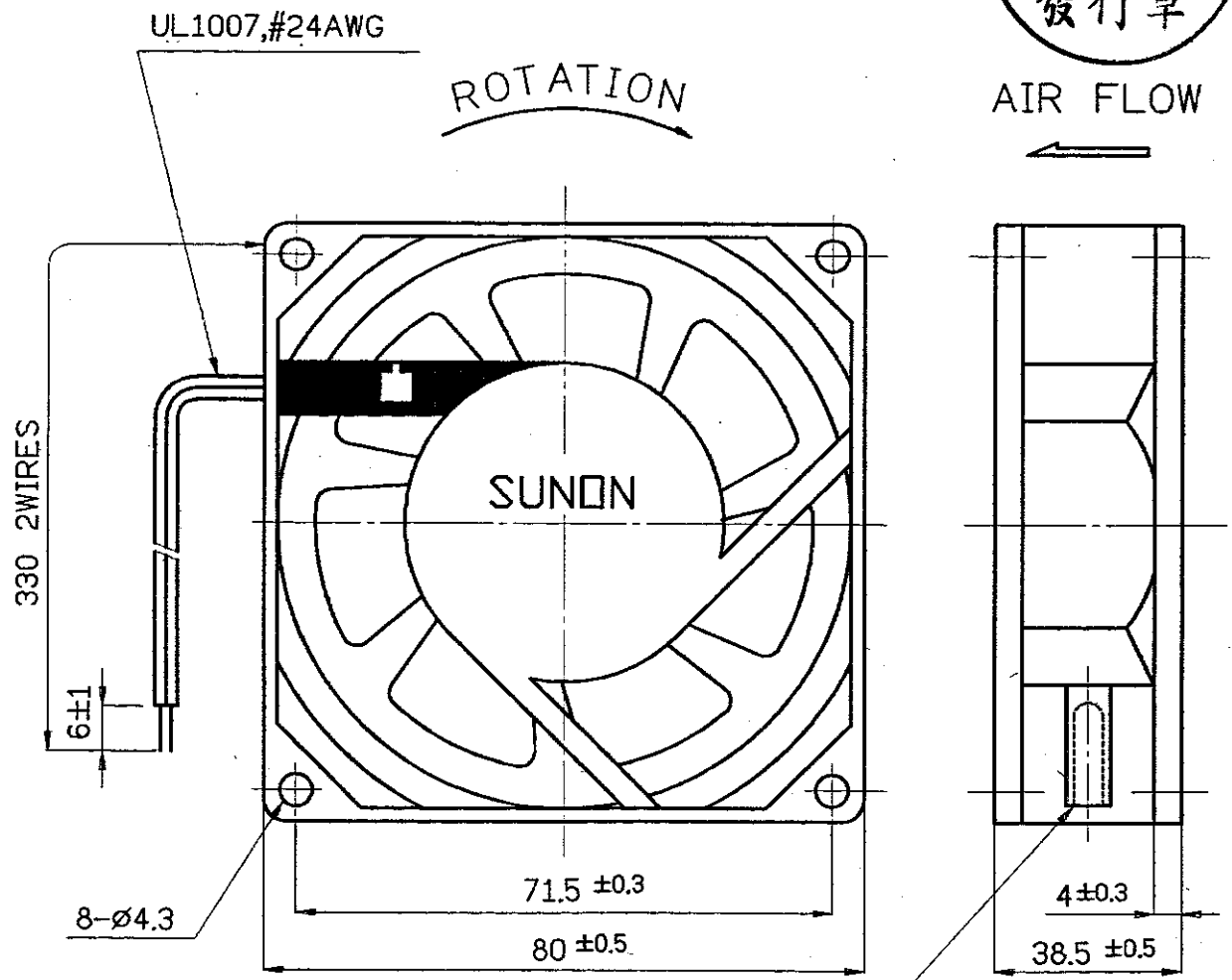

UNIT : mm

建準電機工業股份有限公司 SUNONWEALTH ELECTRIC MACHINE INDUSTRY CO., LTD.	SPEC. NO.	282227300	REVISE DATE	
	ISSUE DATE	03. 18. 1996	EDITION	0
	PAGE	5 OF 5		