

Model 533, 534, 535

Spectrol

7/8" (22mm) Precision Wirewound Potentiometer



FEATURES

- Special Resistance Tolerances to 1%
- Rear Shaft Extensions and Support Bearing
- Non Turn Lug
- Insulating Plastic Shaft
- Special Independent Linearity to $\pm 0.75\%$
- Dual Gang Configuration and Concentric Shafts
- High Torque and Center Tap
- Special Markings and Front Shaft Extensions
- Servo Unit available and Slipping Clutch

ELECTRICAL SPECIFICATIONS

PARAMETER	MODEL 533	MODEL 534	MODEL 535
Resistance Range			
Standard Values	50 Ω to 20K Ω	100 Ω to 100K Ω	50 Ω to 50K Ω
Capability Range	5 Ω to 60K Ω	10 Ω to 200K Ω	5 Ω to 100K Ω
Standard Tol	$\pm 5\%$	$\pm 5\%$	$\pm 5\%$
Linearity (Independent)	$\pm 0.25\%$	$\pm 0.25\%$	$\pm 0.25\%$
Noise	100 Ω ENR	100 Ω ENR	100 Ω ENR
Rotation (Electrical & Mechanical)	$\pm 2\%$	Special $\pm 2\%$	$\pm 2\%$
Power Rating (@ 70°C)	1.0 watts	2.0 watts	1.5 watts
Additional Sections	75% of section 1		
Insulation Resistance	1000M Ω minimum 500VDC		
Dielectric Strength	1000V _{RMS} minimum 60Hz		
Absolute Minimum Resistance	Not to exceed linearity x total resistance or 1 Ω , whichever is greater		
Tempco	20ppm/ $^{\circ}$ C (standard values, wire only)		
End Voltage	0.25% of total applied voltage, maximum		
Phasing	CCW end points - section 2 phased to section 1 within $\pm 2^{\circ}$		
Taps	Center tap only		

MARKING

Unit Identification	Manufacturer's name and model number, resistance value and tolerance, linearity specification date code and terminal identification

RESISTANCE VALUES

Ohms	
533:	50R, 100R, 200R, 500R, 1K, 2K, 5K, 10K, 20K
534:	100R, 200R, 500R, 1K, 2K, 5K, 10K, 20K, 50K, 100K
535:	50R, 100R, 200R, 500R, 1K, 2K, 5K, 10K, 20K, 50K

ORDERING INFORMATION

The Models 533 (3 turn), 534 (10 turn) and 535 (5 turn) can be ordered by stating

534	1	1	XXX/XXX
MODEL	MOUNTING	NUMBER OF SECTIONS	RESISTANCE EIA CODE SECTION #N
	1. Bushing		(consult factory)
Example: 534 - 1 - XXX/XXX	2. Metric Shaft/Thread		

Model 533, 534, 535

7/8" (22mm) Precision Wirewound Potentiometer

Spectrol

DIMENSIONS in millimeters

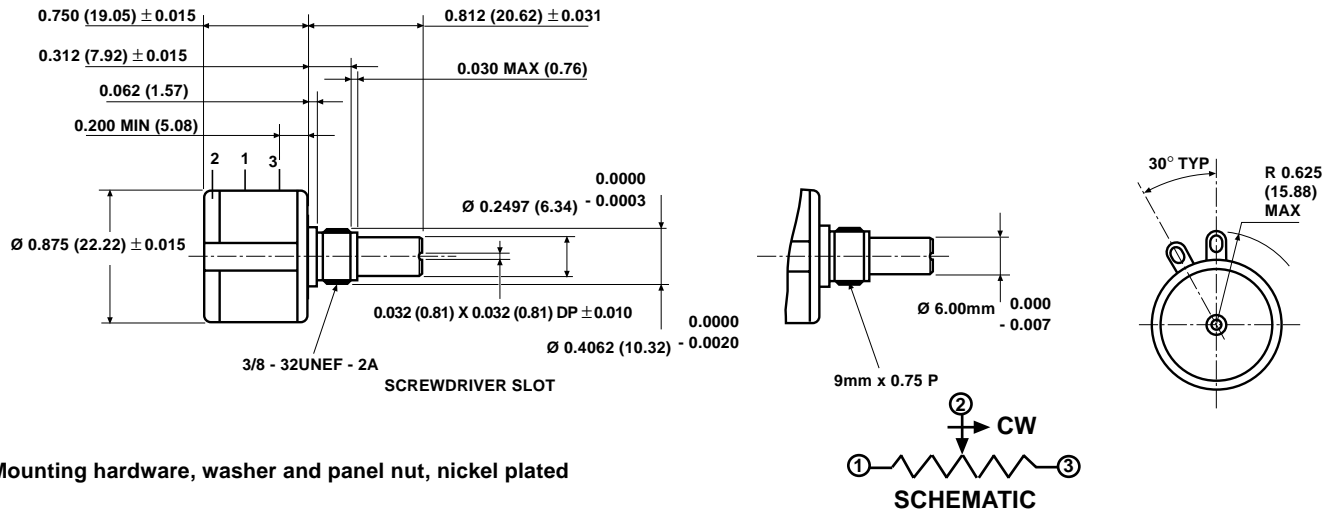

Mounting hardware, washer and panel nut, nickel plated

MECHANICAL SPECIFICATIONS		
PARAMETER		
Bearing Type Bushing	Sleeve bearing	
Torque (maximums): starting	534	533/535
Section 1	0.5 oz - in (36gm - cms)	0.7 oz - in (50gm - cms)
Section 2	0.9 oz - in (65gm - cms)	1.1 oz - in (79gm - cms)
Weight (maximums)		
Section 1	0.75 oz (21.26gm)	
Section 2	1.25 oz (35.44gm)	
Stop Strength	75 oz - in (static) (5.4Kgm - cm)	
Ganging	2 sections maximum	

POWER RATING CHART

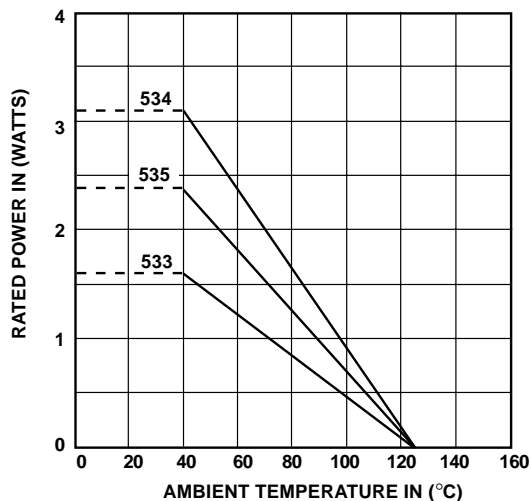

ENVIRONMENTAL SPECIFICATIONS	
Vibration	15g thru 2000Hz
Shock	50g
Rotational Life (Shaft Revolution)	
533	300,000
534	1,000,000
535	500,000
Load Life	900 Hours
Operating Temperature Range	- 55°C to + 125°C
Moisture Resistant Salt Spray	96 Hours

