

2" Single Turn Wirewound Precision Potentiometer



FEATURES

- Servo and Bushing Mount
- 5Ω to 50KΩ

ELECTRICAL SPECIFICATIONS		
PARAMETER	STANDARD	SPECIAL
Total Resistance: Tolerance 50Ω and above Below 50Ω	5Ω to 50KΩ ± 3% ± 5%	85K ± 1% ± 3%
Absolute Minimum Resistance	Linearity X total resistance or 0.5Ω whichever is greater	
End Voltage	Linearity x total applied voltage for total resistance above 20Ω, 2.0% of total applied voltage for 20Ω and below	
Linearity (Independent) 5Ω to 50Ω 50Ω to 200Ω 200Ω to 1KΩ 1K to 10K 10K and above	STANDARD ± 1.0% ± 0.50% ± 0.25% ± 0.25% ± 0.25%	BEST PRACTICAL ± 0.50% ± 0.35% ± 0.20% ± 0.15% ± 0.10%
Noise	100Ω ENR	
Rotation	350° ± 2°	
Power Rating Section 1: 4.0 watts Additional Sections	70°C ambient derated to zero at 125°C 75% of the rating of section 1 (3.0 watts at 70°C)	
Insulations Resistance	1000MΩ minimum 500 VDC	
Dielectric Strength	1000V _{RMS} , 60Hz	
Taps (Extra)	21 available as special, standard tolerance ± 1°	
Phasing (CCW End Points)	Additional sections phased to section 1 within ± 1°	

ORDERING INFORMATION			
The Model 302 can be ordered from this data sheet with a variety of alternate characteristics, as shown. For most rapid service on your order, please state:			
302	1	3	XXX
MODEL	MOUNTING	TOTAL RESISTANCE OF EACH SECTION	NUMBER OF SECTION IN GANG
	1. Screw 2. Bushing 3. Servo	Beginning with the section nearest the mounting end	
Example: Model 302, Screw, 15K/1500Ω/5Ω 3 section			
Example: Model 302, Bushing, 10K, single section			
Example: 302 - 1 - 3 - XXX			
Other characteristics will be standard as described on this data sheet. If special characteristics are required, such as: special linearity tolerance, special resistance tolerance, extra taps, non-linear functions, etc., please state these on your order and allow additional lead time for delivery.			

Model 302

Spectrol

2" Single Turn Wirewound
Precision Potentiometer

DIMENSIONS in inches (millimeters)

SCREW MOUNT

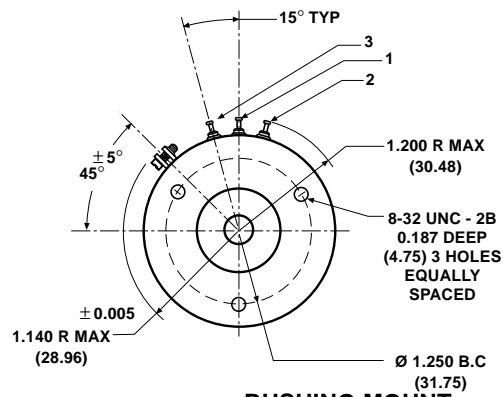
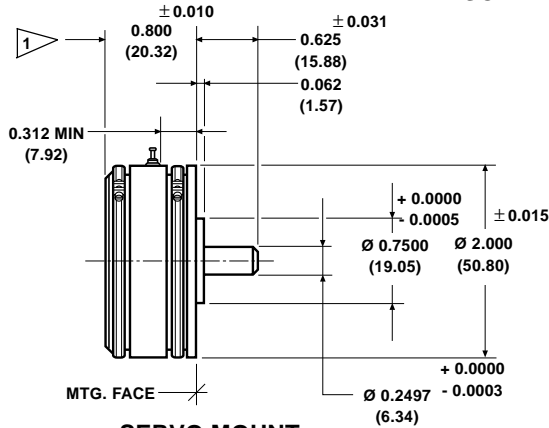

SERVO MOUNT

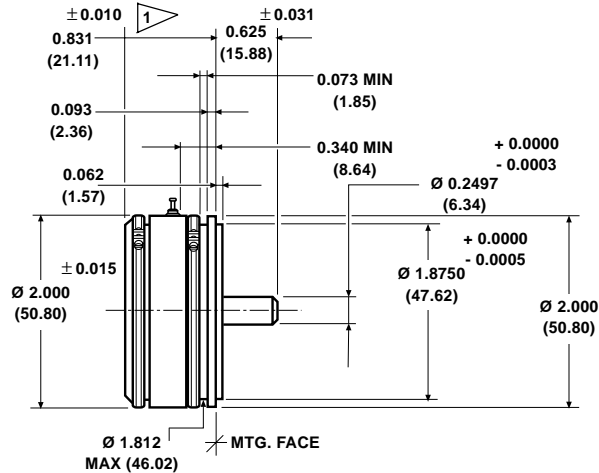

BUSHING MOUNT

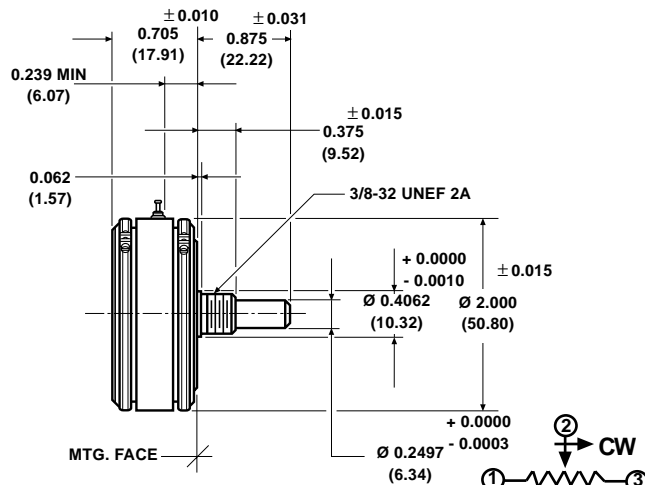

1 ADD 0.500 (12.70) FOE EACH ADDITIONAL SECTION

TOLERANCES: UNLESS OTHERWISE NOTED. DECIMALS ± 0.005 ANGLES ± 2° SCHEMATIC

MECHANICAL SPECIFICATIONS

PARAMETER		
Rotation	360° (continuous)	
Bearing Type	Servo & Screw mount: ball Bushing mount: sleeve	
Ganging	6 sections maximum Terminal alignment, added sections, within ± 10° of section 1 terminals	
Torque (Maximums)	STARTING	RUNNING
1 Section	1.0 oz - in (72.00gm - cm)	0.5 oz - in (36.00gm - cm)
Bushing (1 Section)	1.7 oz - in (122.42gm - cm)	1.0 oz - in (72.00gm - cm)
Each added Section	0.6 oz - in (43.21gm - cm)	0.4 oz - in (28.80gm - cm)
Mechanical Runouts (Maximums)	SERVO AND SCREWING	BUSHING
Shaft TIR/in	0.002 in (0.05cm)	0.002 in (0.05cm)
Pilot dia TIR	0.002 in (0.05cm)	0.002 in (0.05cm)
Lateral TIR	0.003 in (0.08cm)	0.005 in (0.13cm)
Shaft End Play	0.005 in (0.13cm)	0.005 in (0.13cm)
Shaft Radial Play	0.002 in (0.05cm)	0.003 in (0.08cm)
Moment of Inertia	2.0gm - cm ² per section maximum	
Weight (Maximums)		
Single Section:	4.0 oz (113.40gm)	
Each Additional Section:	1.2 oz (34.02gm)	

2" Single Turn Wirewound Precision Potentiometer

Spectrol

MATERIAL SPECIFICATIONS	
Housing and Lids	Aluminum, anodized
Shaft and Clamp Rings	Stainless steel, non-magnetic non-passivated
Terminals	Brass, plated for solderability
Bushing Mount Hardware Lockwasher Internal Tooth: Panel nut:	Steel, nickel plated Brass, nickel plated

ENVIRONMENTAL SPECIFICATIONS	
Vibration	15g thru 2000 Hz
Shock	50g
Salt Spray	96 Hours
Rotational Life	1 million shaft revolutions
Temperature Range	- 55°C to + 125°C
Humidity Cycling:	-
Moisture Resistance	-

MARKING	
Unit Identification	Units shall be marked with Spectrol name, model no and date code, and on each section, resistance, resistance tolerance, linearity and terminal identification

POWER RATING CHART
(Ratings for cup No. 1.
Additional cups 75% of values shown)

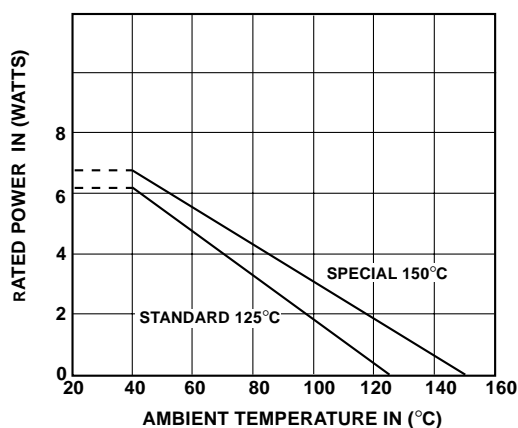

RESISTANCE ELEMENT DATA					
RESISTANCE VALUES (Ω)	RESOLUTION (%)	OHMS PER TURN	MAXIMUM CURRENT AT 70°C AMBIENT (mA)	MAXIMUM VOLTAGE ACROSS COIL (V)	WIRE TEMP. COEF. (ppm/°C)
5	0.320	0.016	893	4.48	800
10	0.200	0.020	633	6.32	800
20	0.165	0.033	447	8.95	800
50	0.148	0.074	283	14.1	800
100	0.151	0.151	200	20.0	20
200	0.126	0.252	141	28.4	20
500	0.115	0.573	89.4	44.7	20
1K	0.098	0.981	63.3	63.2	20
2K	0.085	1.70	44.7	89.5	20
5K	0.059	2.93	28.3	141	20
10K	0.051	5.16	20.0	200	20
20K	0.043	8.55	14.1	284	20
50K	0.032	15.80	8.94	447	20