

Model 152, 158, 159

Spectrol

7/8" (19mm) Single Turn Wirewound, Conductive Plastic, Cermet Precision Potentiometer



FEATURES

- Rugged, High-Quality, All Metal Housing
- Short Length Behind Panel (11/32")
- Choice of Three Elements for Broad Resistance Range- 5Ω to 2MΩ
- No Glued Joints
- Extra Taps AVAILABLE
- High Current Capacity, Parallel-Gap-Welded Terminations (152)

ELECTRICAL SPECIFICATIONS			
PARAMETER			
Total Resistance (152) Standard Range	5Ω to 20KΩ Special to 40KΩ		
Tolerance	STANDARD	SPECIAL	
50Ω and above:	± 3%	± 1%	
Below 50Ω	± 5%	± 3%	
158 Conductive plastic Standard Range	500Ω to 50KΩ		
Tolerance	± 20%	± 5%	
159 Cermet Standard Range	500Ω to 2MΩ		
Tolerance	± 20	± 5%	
Linearity (Independent) (152) Total Resistance	STANDARD	BEST PRACTICAL	
5Ω to 100Ω	± 1.0%	± 0.75%	
100Ω to 500Ω	± 1.0%	± 0.50%	
500Ω and above	± 0.5%	± 0.35%	
(158 & 159) Standard	± 0.5%	± 0.25%	
Noise	(152) 100Ω ENR		
Output Smoothness	(158 & 159) 0.1% maximum		
Power Rating (@ 40°C Ambient)	MODEL 152 2 watts Derated to zero at 125°C	MODEL 158 1 watts	MODEL 159 3.5 watts To zero at 150°C
Rotation	340° (152) ± 2° (158 and 159) ± 4°		
Insulation Resistance	1000MΩ minimum 500 VDC		
Dielectric Strength	1000V _{RMS} , 60Hz		
Absolute Minimum Resistance	Not to exceed linearity times total resistance or 0.5Ω whichever is greater (152 only)		
Minimum Voltage	0.5% max		
Temperature Coefficient of Resistance	MODEL 152 Refer to standard resistance element data	MODEL 158 ± 400 ppm/°C	MODEL 159 ± 100 ppm/°C

ORDERING INFORMATION

The Model 152, 158 and 159 can be ordered from this data sheet with a variety of alternate characteristics, as shown. For most rapid service on your order, please state:

152, 158 or 159
MODEL

2
MOUNTING

XXX
TOTAL RESISTANCE

1. Servo
2. Bushing

Example: Model 152, Servo, 10K
Example - Model 158, Bushing, 5K
Example - Model 159, Servo, 1MΩ

Example: **152, 158, 159 - 2 - XXX**

Other characteristics will be standard as described on this data sheet. If special characteristics are required, such as: special linearity and resistance tolerance, special resistance tolerance, high torque, 1/8 shaft - 1/4 - 32 bushing, stops, non - linear functions, etc., state these on your order

7/8" (19mm) Single Turn Wirewound, Conductive Plastic Spectrol Cermet Precision Potentiometer

DIMENSIONS in inches (millimeters)

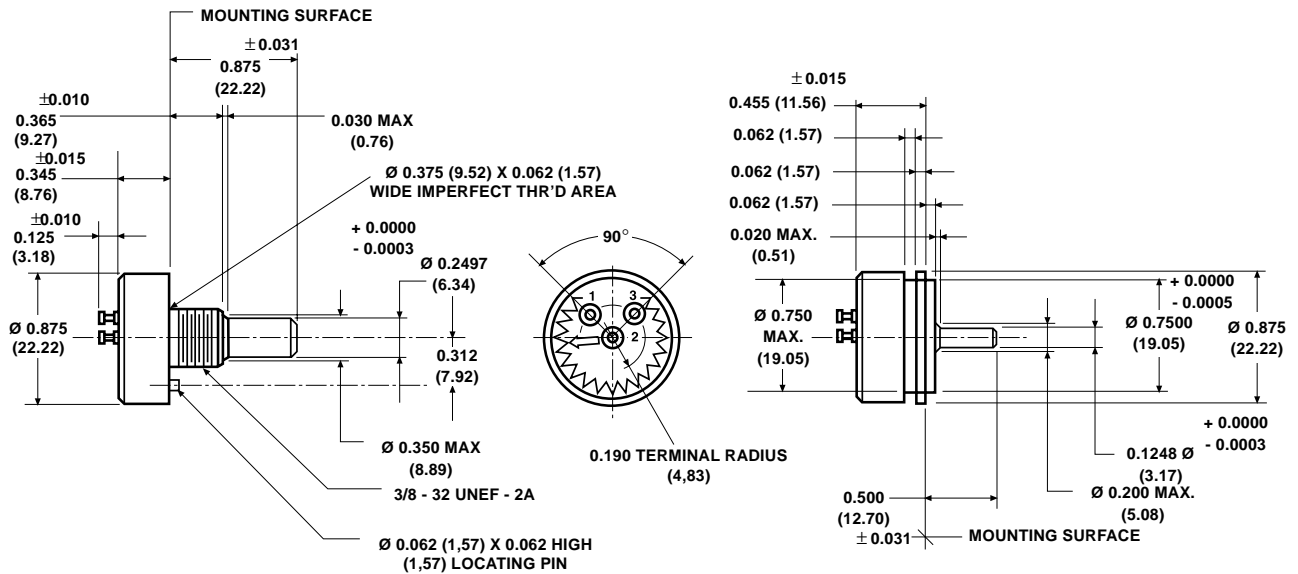

TOLERANCES: UNLESS OTHERWISE NOTED.
DECIMALS ± 0.005 ANGLES ± 2°

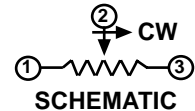

MECHANICAL SPECIFICATIONS		
PARAMETER		
Rotation	360° continuous	
Bearing Type	Servo Mount: Ball Bearing Bushing Mount: Sleeve Bearing	
Torque (Maximums)	STARTING	RUNNING
Servo	0.25 oz - in (18.00gm - cm)	0.15 oz - in (10.80gm - cm)
Bushing	0.30 oz - in (21.60gm - cm)	0.25 oz - in (18.00gm - cm)
Mechanical Runouts (Maximums)	BUSHING	SERVO
Shaft Runout	0.002 in (0.05cm)	0.002 in (0.05cm)
Pilot dia. Runout	—	0.002 in (0.05cm)
Lateral Runout	0.005 in (0.13cm)	0.002 in (0.05cm)
Shaft End Play	0.006 in (0.15cm)	0.005 in (0.13cm)
Shaft Radial Play	0.003 in (0.08cm)	0.002 in (0.05cm)
Weight	0.5 oz maximum (14.18gm)	

Model 152, 158, 159

Spectrol 7/8" (19mm) Single Turn Wirewound, Conductive Plastic
Cermet Precision Potentiometer

MATERIAL SPECIFICATIONS	
Housing	Aluminum, anodized
Shaft	Stainless steel, non-magnetic non-passivated
Rear Lid	Molded glass filled phenolic
Terminals	Brass, plated for solderability
Bushing Mount Hardware Lockwasher Internal Tooth: Panel nut:	Steel, nickel plated Brass, nickel plated

MARKING	
Unit Identification	Units shall be marked with Spectrol name, model number, resistance and tolerance, linearity terminal identification and data code. Applicable test procedures: Model 152, MIL-R-12934; Model 158 & 159 MIL-R-39023

ENVIRONMENTAL SPECIFICATIONS		
Vibration	15g thru 2000Hz	
Shock	50g	
Salt Spray	96 hours	
Rotational Life Shaft revolution:	Bushing	Servo
152	1 million	2 million
158	2 million	10 million
159	2 million	5 million
Load Life	900 Hours	
Operating Temperature Range	(152, 158) -55°C to +125°C (159) -55°C to - +150°C	

POWER RATING CHART

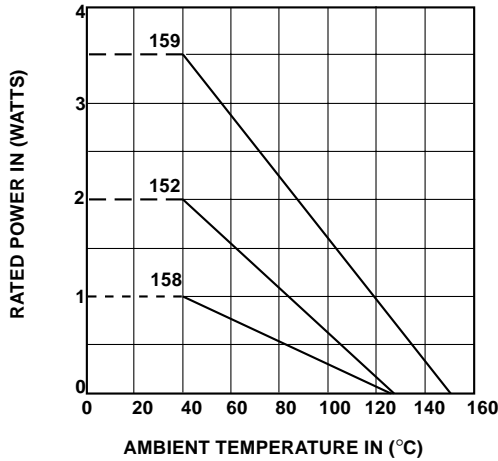

RESISTANCE ELEMENT DATA					
STANDARD RESISTANCE VALUES (Ω)	RESOLUTION (%)	OHMS PER TURN	MAXIMUM CURRENT AT 40°C AMBIENT (mA)	MAXIMUM VOLTAGE ACROSS COIL (V)	WIRE TEMP. COEF. (ppm/°C)
5	0.681	0.034	632	3.16	180
10	0.570	0.057	447	4.47	180
20	0.447	0.089	316	6.32	180
50	0.402	0.201	200	10.0	20
100	0.309	0.309	141	14.1	20
200	0.254	0.508	100	20.0	20
500	0.214	1.07	63.2	31.6	20
1K	0.210	2.10	44.7	44.7	20
2K	0.184	3.69	31.6	63.2	20
5K	0.130	6.50	20.0	100	20
10K	0.101	10.1	14.1	141	20
20K	0.081	16.2	10.0	200	20
30K	0.075	22.7	8.12	244	20
40K	0.063	25.2	7.07	283	20