

Features

- Bushing mount
- Optional AR pin feature
- Non-standard features and specifications available
- Gangable

BOURNS®

3543/3545 - Precision Potentiometer

Electrical Characteristics ¹	3543 3-Turn	3545 5-Turn
Standard Resistance Range	20 to 50 K ohms	50 to 50 K ohms
Total Resistance Tolerance	±5 %	±5 %
Independent Linearity	±0.25 %	±0.25 %
Effective Electrical Angle	1080° +10°, -0°	1800° +10°, -0°
Absolute Minimum Resistance/ Minimum Voltage	1 ohm or 0.1 % maximum (whichever is greater)	1 ohm or 0.1 % maximum (whichever is greater)
Noise	100 ohms ENR maximum	100 ohms ENR maximum
Dielectric Withstanding Voltage (MIL-STD-202, Method 301) Sea Level	1,000 VAC minimum	1,000 VAC minimum
Power Rating (Voltage Limited By Power Dissipation or 224 VAC [3543] or 273 VAC [3545], Whichever Is Less)		
+70 °C	1 watt	1.5 watt
+125 °C	0 watt	0 watt
Insulation Resistance (500 VDC)	1,000 megohms minimum	1,000 megohms minimum
Resolution	See recommended part nos.	See recommended part nos.

Environmental Characteristics ¹		
Operating Temperature Range	+1 °C to +125 °C	+1 °C to +125 °C
Storage Temperature Range	-55 °C to +125 °C	-55 °C to +125 °C
Temperature Coefficient Over Storage Temperature Range ²	±50 ppm/°C maximum/unit	±50 ppm/°C maximum/unit
Vibration	15 G	15 G
Wiper Bounce	0.1 millisecond maximum	0.1 millisecond maximum
Shock	50 G	50 G
Wiper Bounce	0.1 millisecond maximum	0.1 millisecond maximum
Load Life	1,000 hours, 1 watt	1,000 hours, 1.5 watts
Total Resistance Shift	±2 % maximum	±2 % maximum
Rotational Life (No Load)	300,000 shaft revolutions	500,000 shaft revolutions
Total Resistance Shift	±5 % maximum	±5 % maximum
Moisture Resistance (MIL-STD-202, Method 103, Condition B) Total Resistance Shift	±2 % maximum	±2 % maximum
IP Rating	IP 40	IP 40

Mechanical Characteristics ¹		
Stop Strength	53 N-cm (75 oz.-in.) min.	
Mechanical Angle	1080° +10°, -0° (3543); 1800° +10°, -0° (3545)	
Torque (Starting & Running)	0.35 N-cm (0.5 oz.-in.) max.	
Mounting	170-200 N-cm (15-18 lb.-in.)	
Shaft Runout	0.08 mm (0.003 in.) T.I.R.	
Lateral Runout	0.13 mm (0.005 in.) T.I.R.	
Shaft End Play	0.25 mm (0.010 in.) T.I.R.	
Shaft Radial Play	0.08 mm (0.003 in.) T.I.R.	
Pilot Diameter Runout	0.08 mm (0.003 in.) T.I.R.	
Backlash	1.0° maximum	
Weight	Approximately 21 gm	
Terminals	Gold-plated solder lugs	
Soldering Condition	Recommended hand soldering using Sn95/Ag5 no clean solder, 0.025 " wire diameter. Maximum temperature 399 °C (750 °F) for 3 seconds. No wash process to be used with no clean flux.	
Marking	Manufacturer's name and part number, resistance value and tolerance, linearity tolerance, wiring diagram, and date code.	
Ganging (Multiple Section Pots.)	2 cups maximum	
Hardware	One lockwasher (H-37-2) and one mounting nut (H-38-2) is shipped with each potentiometer.	

¹At room ambient: +25 °C nominal and 50 % relative humidity nominal, except as noted.
²Consult manufacturer for complete specification details.

Recommended Part Numbers

Part Number*	Resistance (Ω)	Resolution (%)
3543S-1-102	1,000	.077
3543S-1-202	2,000	.062
3543S-1-502	5,000	.047
3543S-1-103	10,000	.040

Part Number	Resistance (Ω)	Resolution (%)
3545S-1-102	1,000	.043
3545S-1-202	2,000	.044
3545S-1-502	5,000	.038
3545S-1-103	10,000	.029

3543S-1/3545S-1

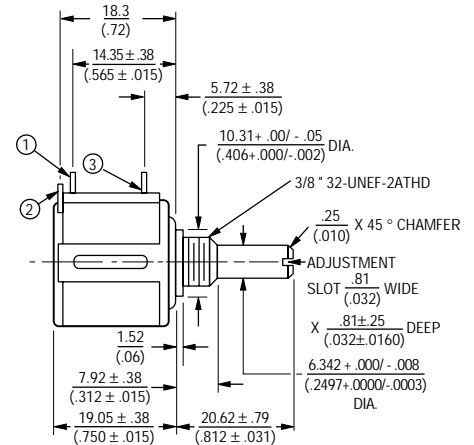

ADD .75 (19 MM) FOR ADDITIONAL CUPS.

OPTIONAL ANTIROTATION LUG
(-91) 1.42 X .50 ON 7.4 RADIUS
(.056 X .02) ON (.29)
LENGTH 1.27 FROM MOUNTING SURFACE.
(SUGGESTED PANEL HOLE 1.6 DIA.)
(.063)

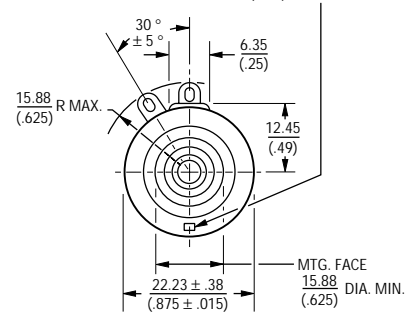

TOLERANCES: EXCEPT WHERE NOTED

DECIMALS: XX ± .25 (010), XXX ± .13 (005)

FRACTIONS: ±1/64

DIMENSIONS: MM (IN.)

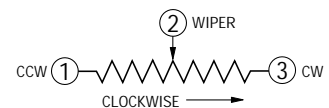

BOLDFACE LISTINGS ARE IN STOCK AND READILY AVAILABLE THROUGH DISTRIBUTION.

FOR SERVO MOUNT VERSION AND OTHER OPTIONS CONSULT FACTORY.

MATERIAL DATA SHEET



Reliable Electronic Solutions

Material #	3545H	
Product Line	Precisions	
Posted Date	03/02/2005	
Compliance Date	Since Inception	
RoHS Compliant	Yes	

No.	Construction element	Material group	Material weight [g]	Materials	CAS If applicable	Average mass [%]	Sum [%]
1	Shaft	Brass Alloy	9.1625	Copper	7440-50-8	70%	39.6045%
				Zinc	7440-66-6	30%	
2	C-Ring	Stainless Steel Alloy	0.009	Iron	7439-89-6	48-89%	0.0389%
				Chromium	7440-47-3	10-27%	
				Nickel	7440-02-0	0-22%	
				Manganese	7439-96-5	0-15%	
				Tungsten	7440-33-7	0-4%	
				Molybdenum	7439-98-7	0-4%	
				Aluminum	7429-90-5	0-2%	
				Copper	7440-50-8	0-4%	
				Silicon	7440-51-3	0-5%	
				Cobalt	7440-48-4	0-5%	
3	Bushing	Aluminum Alloy	1.1765	Aluminum	7429-90-5	100%	5.0854%
4	Rotor Molded	PBT	1.325	Glass	65997-17-3	10-30%	5.7272%
				PBT	*****	65-89%	
				Antimony Oxide	1309-64-4	1-5%	
5	Lock Washer	Stainless Steel Alloy	0.008	Iron	7493-89-6	52-78%	0.0346%
				Chromium	7440-47-3	12-24%	
				Nickel	7440-02-0	6.0-19%	
				Molybdenum	7439-98-7	0-5.0%	
				Silicon	7440-21-3	0-6%	
				Manganese	7439-96-3	0-2.0%	
				Tungsten	7440-33-7	0-1.8%	



Reliable Electronic Solutions

				Aluminum	7429-90-5	0-1.5%			
				Columbium	7440-03-1	0-1.0%			
				Titanium	7440-32-6	0-0.7%			
				Copper	7440-50-8	0.075%			
				Cobalt	7440-48-4	0.1.0%			
6	Cover Molded	PBT	0.7005	Glass	65997-17-3	10-30%	3.0279%		
				PBT	*****	65-89%			
				Antimony Oxide	1309-64-4	1-5%			
7	Hex Nut	Brass Alloy	1.179	Copper	7440-50-8	55.5-86%	5.0962%		
				Zinc	7440-66-6	13.90-42.5%			
				Lead	7439-92-1	.00-3.7%			
				Tin	7440-31-5	.00-1.2%			
				Aluminum	7429-90-5	.00-2.3%			
				Manganese	7439-96-5	.00-3.5%			
				Silicon	7440-21-3	.00-1.5%			
				Nickel	7440-02-0	.00-.02%			
8	Lock Washer	Steel Alloy	0.2945	Carbon	7440-11-0	0.51%	1.2730%		
				Manganese	7439-98-5	0.75%			
				Phosphorus	7723-14-0	0.02%			
				Sulfur	7704-39-9	0.025%			
				Iron	7439-89-6	98.695%			
		Zinc Plating	0.002975	Chromium	16065-83-1	0.1%	0.0129%		
				Tin	7440-31-5	0.64%			
				Zinc	7440-66-6	99.25%			
9	Lube	Lubricating Grease	0.00815	Polysiloxane	*****	100%	0.0352%		
10	Slider Molded	PBT	0.193	Glass	65997-17-3	10-30%	0.8342%		
						PBT		*****	65-89%
						Antimony Oxide		1309-64-4	1-5%
11	Contact Spring	Metal Alloy	0.006	Silver	7440-22-4	30.0%	0.0259%		
						Copper		7440-50-8	14.0%
						Zinc		7440-66-6	1.0%
						Platinum		7440-06-4	10.0%
12	Collector Bar	Nickel Silver Alloy	0.065	Copper	7440-50-8	50-80%	0.2810%		
						Nickel		7440-02-0	7-19.5%
						Lead		7439-92-1	0-2.5%
						Zinc		7440-66-6	Remainder
13	Slider Molded	PBT	0.193	Glass	65997-17-3	10-30%	0.8342%		



Reliable Electronic Solutions

				PBT	*****	65-89%	
				Antimony Oxide	1309-64-4	1-5%	
14	Strap	Metal Alloy	2.303	Copper	7440-50-8	53.5-71.0%	9.9546%
				Lead	7439-92-1	0.1	
				Nickel	7439-02-0	21.0	
				Zinc	7440-66-6	13.24-32.0%	
				Gold	7440-57-5	>90.00%	
15	Terminal Wiper Gold Plated	Plating Brass Alloy	0.3	Copper	7440-50-8	59-96%	1.2967%
				Zinc	7440-66-6	4-41%	
				Lead	7439-92-1	0.03-0.3%	
				Polyester Resin	*****	66%	
16	Beta Low Ink	Conductive Plastic	0.004	Carbon	7440-11-0	14%	0.0173%
				Blend of Allyl Resin & Diallyl	*****	20%	
17	Mandrel Winding Wire	Metal	2.252	Copper	7440-50-8	92-99%	9.7342%
				Organic coatings	*****	1-8%	
18	Resist Wire	Copper Alloy	0.5783	Nickel	7440-02-0	2-47%	2.4997%
				Copper	7440-50-8	Balance	
				Iron	1300-37-1	Max 3%	
				Manganese	7439-96-5	Max 3%	
				Cobalt	7440-48-4	Max 0.5%	
19	Varnish	Insulating Varnish	0.2002	Phenolic Resin	*****	100%	0.8654%
20	Terminal Cover Molded	PBT	0.2905	Carbon Black	1333-86-4	0.1-1	1.2557%
				Glass	65997-17-3	10-30%	
				PBT	*****	65-89%	
				Antimony Oxide	1309-64-4	1-5%	
21	Terminal	Brass Alloy	0.0375	Copper	7440-50-8	59-96%	0.1621%
				Zinc	7440-66-6	4-41%	
				Lead	7439-92-1	0.03-0.3%	
22	Housing Molded	PBT	2.654	Glass	65997-17-3	10-30%	11.4718%
				PBT	*****	65-89%	
				Antimony Oxide	1309-64-4	1-5%	
23	Tab	Solder	0.1924	Cadmium	7440-43-9	18%	0.8316%
				Copper	7440-50-8	15.5%	
				Nickel	7440-02-0	Remainder	
				Silver	7440-22-4	50%	
				Zinc	7440-66-6	16.5%	
		Total weight	23.135025				

