

Industrial-Graded Geared Potentiometers

Series IGP



Special features

- reduction gearing
3:1, 5:1, 10:1
- good linearity
0.1 % (standard)
- long life typically
100 x 10⁶ movements
- mechanical rotation
- robust construction
with 10 mm shaft
- protection class IP 65

Using this potentiometer a maximum angular rotation of 3800° can be converted into a voltage proportional to the angle of rotation, through the medium of a conductive-plastic potentiometer.

This special „heavy-duty“ version is designed to measure angular or linear displacement under the most difficult of environmental conditions. Simply yet robustly built, these units are suitable for use in all manner of industrial applications and engineering industry.

The cast housing is water-tight. The single stage gearing is exceptionally backlash-free. Heavy-duty bearings allow for high axial loading on the shaft; gearwheels or even chain drives may be used to directly

drive the shaft.

Sealing is achieved through the use of a stepped bush whilst electrical connections are made via a plug and socket mounted on the side of the unit.

Description

Case	aluminium varnished, entry sealed using special stepped bush
Shaft	stainless steel
Bearings	stainless ball bearings
Reduction gearing	single-stage gearing exhibiting low backlash
Resistance element	conductive plastic
Wiper assembly	precious metal multi-finger wiper
Mounting	any optional position
Electrical connections	7pin all-metal plug and socket, freely rotatable, 90° right-angled, protection class IP65, bayonet catch

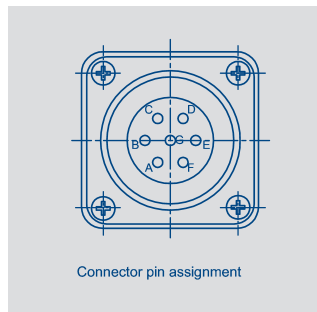
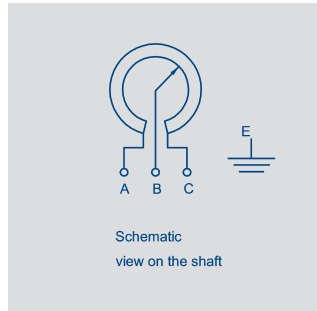
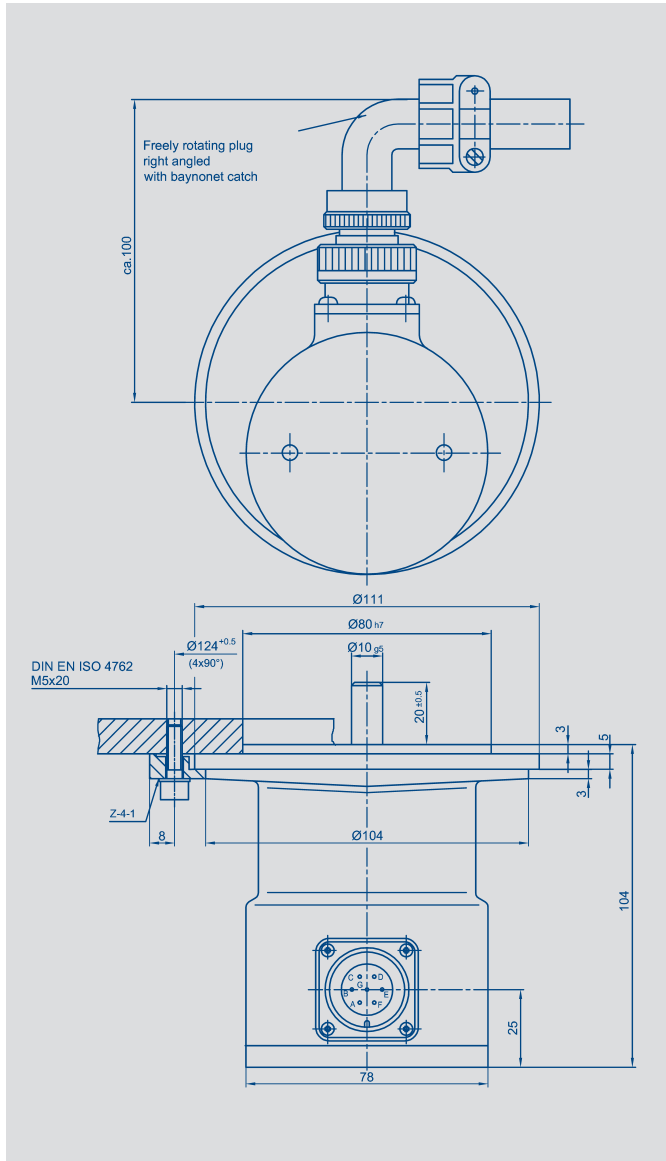

Type designations	IGP3P6501 A502	IGP5P6501 A502	IGP10P6501 A502	
Mechanical Data				
Dimensions	see drawing			
Mounting	with 4 clamps Z 4 - 1			
Mechanical travel	360, continuous			°
Permitted shaft loading (axial and radial) static or dynamic force	300			N
Starting torque	<10			Ncm
Weight	approx. 1300			g
Reduction ratio	3.11:1	5.19:1	10.77:1	
Electrical Data				
Actual electrical travel	1095 + 15	1830 + 20	3800 + 45	°
Nominal resistance	5			kΩ
Resistance tolerance	±20			%
Independent linearity	±0.1 (0.05 on request)			%
Repeatability	typ. 0.002			%
Max. permissible applied voltage	42			V
Max. wiper current in case of malfunction	10			mA
Recommended operating wiper current	≤ 1			μA
Effective temperature coefficient of the output-to-applied voltage ratio	typ. 5			ppm/K
Insulation resistance (500 VDC, 1 bar, 2 s)	≥ 10			MΩ
Dielectric strength (50 Hz, 2 s, 1 bar, 500 VAC)	≤ 100			μA

Environmental Data			
Temperature range	-40...+100		°C
Vibration	5...2000 A _{max} = 0.75 a _{rmax} = 20		Hz mm g
Shock	50 11		g ms
Life	100 x 10 ⁶		movem.
Protection class	IP 65 (DIN 400 50 / IEC 529)		

Included in delivery

4 mounting clamps Z4-1,
1 right angle plug Cannon Nr.
CA 08 COM-E16S-1S-B,
1 anti-kink sleeve

Recommended accessories

Spring operated backlash free
coupling Z110 G10,
Process-controlled indicators
MAP... with display,
Signal conditioner MUP.../
MUK ... for standardized out-
put signals

Important

All the values given in this
data sheet for linearity, lifetime
and temperature coefficient in
the voltage dividing mode are
quoted for the device opera-
ting with the wiper voltage dri-
ving on operational amplifier
working as a voltage follower,
where virtually no load is ap-
plied to the wiper ($I_e \leq 1 \mu\text{A}$).

Order designations

Type	Art.no.	Ratio
IGP10 P6501 A502	002624	Reduction 10:1
IGP5 P6501 A502	002614	Reduction 5:1
IGP3 P6501 A502	002604	Reduction 3:1