

# MODEL 7280 SERIES

7/8" Diameter

10-Turn

Wirewound

Precision Potentiometer



2

## MODEL STYLES

7281	1/8" Shaft, 1/4" Bushing
7283	1/8" Shaft, Servo
7284	6mm Shaft, 3/8" Bushing
7286	1/4" Shaft, 3/8" Bushing

## ELECTRICAL

Resistance Range, Ohms	100 to 100K
Standard Resistance Tolerance	±5%
Minimum Practical Resistance Tolerance	±1%
Independent Linearity	±0.25%
Minimum Practical Independent Linearity	±0.15%, < 300 Ohms ±0.075%, ≥ 300 Ohms
Power Rating, Watts	2.0 at 70°C derating to 0 at 125°C
Dielectric Strength	1,000V rms
Insulation Resistance, Minimum	1,000 Megohms
Noise, Maximum	100 Ohms
Actual Electrical Travel	3600° + 10° - 0°, > 100 Ohms 3600° + 10° - 5°, ≤ 100 Ohms
Tap Tolerance	±3°
End Voltage, Maximum	0.25% of input voltage

Specifications subject to change without notice.

**ENVIRONMENTAL (MIL-R-12934)**

Operating Temperature Range	Static: -55°C to +125°C Dynamic: -40°C to +125°C
Temperature Cycling	5 cycles, -55°C to +125°C (5% ΔR)
Shock, 6ms Sawtooth	100G's (0.1ms discontinuity max.)
Vibration	15G's, 10 to 2,000 Hz (5% ΔR, 0.1ms discontinuity max.)
Moisture Resistance	Five 24 hour cycles (3% ΔR)
High Temperature Exposure	1,000 hours at 125°C (5% ΔR)
Rotational Load Life	1 mil. shaft rev. + 900 hrs. at rated wattage at 70°C (5% ΔR)

**MECHANICAL**

Total Mechanical Travel	3600° + 15° - 0°	
Number of Gangs, Maximum	2	
Weight, Nominal (single gang)	0.75 oz.	
Backlash, Maximum	1°	
	<b>7281, 7284, 7286</b>	<b>7283</b>
Static Stop Strength	60 oz.-in.	36 oz.-in.
Panel Nut Tightening Torque, Maximum	25 lb.-in.	N/A
Shaft End Play, Maximum	.010"	.005"
Shaft Runout, T.I.R., Maximum	.003"	.002"
Pilot Diameter Runout, T.I.R., Maximum	.004"	.002"
Lateral Runout, T.I.R., Maximum	.005"	.004"
Shaft Radial Play, Maximum	.003"	.002"
Start/Run Torque, Maximum (per gang)	0.8 oz.-in.	0.6 oz.-in.

**STANDARD RESISTANCE VALUES, OHMS**

Total Resistance	Theoretical Resolution (% Nominal)	Tempco of Wire
100	0.059	±20 ppm/°C
200	0.037	±20 ppm/°C
500	0.030	±20 ppm/°C
1K	0.024	±20 ppm/°C
2K	0.020	±20 ppm/°C
5K	0.018	±20 ppm/°C
10K	0.017	±20 ppm/°C
20K	0.016	±20 ppm/°C
50K	0.010	±20 ppm/°C
100K	0.008	±20 ppm/°C

## OUTLINE DIMENSIONS (Inch/mm)

Models 7281, 7284 and 7286

Bushing Mount with Sleeve Bearing

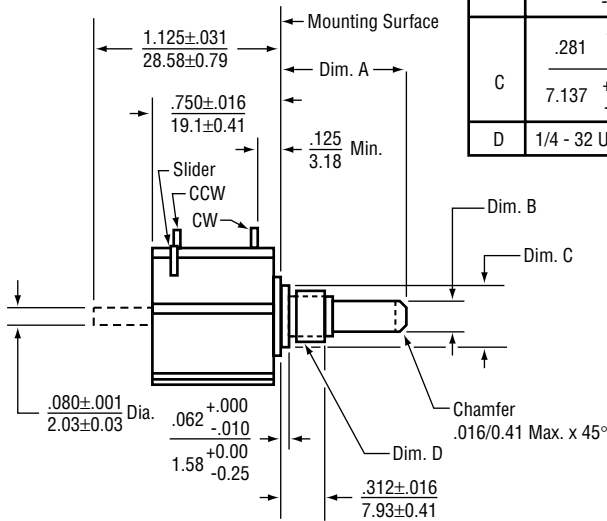

Dim.	7281	7284	7286
A	$\frac{.688 \pm .031}{17.475 \pm 0.787}$	$\frac{.812 \pm .031}{20.625 \pm 0.787}$	$\frac{.812 \pm .031}{20.625 \pm 0.787}$
B	$\frac{.1248 +0.0000}{3.1699 +0.0000}$ Dia. $\frac{-0.0003}{-0.0076}$	$\frac{.2362 +0.0000}{6.0000 +0.0000}$ Dia. $\frac{-0.0005}{-0.0127}$	$\frac{.2500 +0.0000}{6.3500 +0.0000}$ Dia. $\frac{-0.0005}{-0.0127}$
C	$\frac{.281 +0.000}{7.137 +0.000}$ Dia. $\frac{-0.002}{-0.051}$	$\frac{.406 +0.000}{10.312 +0.000}$ Dia. $\frac{-0.002}{-0.051}$	$\frac{.406 +0.000}{10.312 +0.000}$ Dia. $\frac{-0.002}{-0.051}$
D	1/4 - 32 UNEF Thread	3/8 - 32 UNEF Thread	3/8 - 32 UNEF Thread

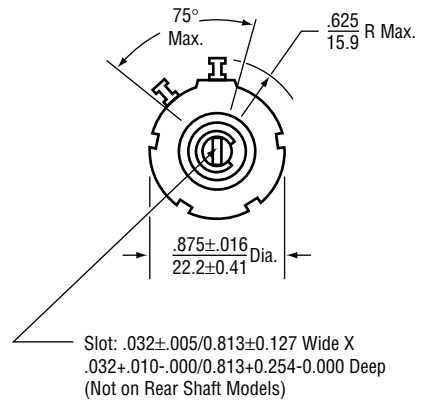

## OPTIONAL TERMINAL CONFIGURATION

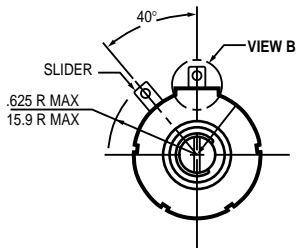

Use Special Feature Code "FT" to order.

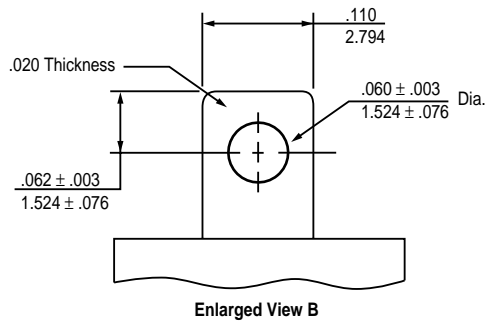

Enlarged View B



## SPECIAL FEATURES

Center Tap	CT
Linearity Tape	LT
Rear Shaft Extension (7283, 7286 single cup only)	RS
Flatted Shaft	FS
Slotted Shaft (Standard on single cup 7286 without RS)	SS
Shaft Lock (7281, 7286 only)	SL
High Torque, 2–6 oz.-in. (7286 only)	HT
Additional Gangs	2G
Gold Plated Solder Lug Terminals (See Optional Terminal Configuration)	FT

2

## ORDERING INFORMATION

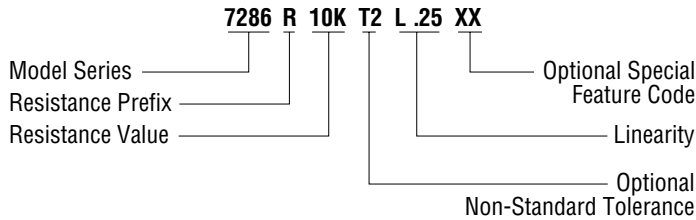

## MATCHING TURNS COUNTING DIALS

7281: RBJ, 2601, 2641

7286: 2606, 2607, 2626, 2627, 2646, 2647, 2126, 2606S, 2607S, 2646S, 2647S, RB

## CIRCUIT DIAGRAM

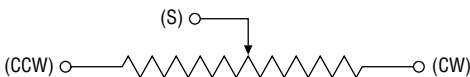

## NOTES

Metric equivalents, based on 1 inch = 25.4mm are rounded to the same number of significant figures as in the original English units and are provided for general information only.

Tolerances unless otherwise specified:  
 Linear =  $\pm .01$  inches  
 (.25mm)  
 Angular =  $\pm 2$  degrees

