

Features

- Single (EL2176C) and dual (EL2276C) topologies
- 1 mA supply current (per amplifier)
- 70 MHz -3 dB bandwidth
- Low cost
- Fast disable
- Powers down to 0 mA
- Single- and dual-supply operation down to $\pm 1.5V$
- 0.15%/0.15° diff. gain/diff. phase into 150 Ω
- 800V/ μs slew rate
- Large output drive current: 100 mA (EL2176C) 55 mA (EL2276C)
- Also available without disable in single (EL2170C), dual (EL2270C) and quad (EL2470C)
- Higher speed EL2180C/EL2186C family also available (3 mA/250 MHz) in single, dual and quad

Applications

- Low power/battery applications
- HDSL amplifiers
- Video amplifiers
- Cable drivers
- RGB amplifiers
- Test equipment amplifiers
- Current to voltage converters

Ordering Information

Part No.	Temp. Range	Package	Outline #
EL2176CN	-40°C to +85°C	8-Pin PDIP	MDP0031
EL2176CS	-40°C to +85°C	8-Pin SOIC	MDP0027
EL2276CN	-40°C to +85°C	14-Pin PDIP	MDP0031
EL2276CS	-40°C to +85°C	14-Pin SOIC	MDP0027

General Description

The EL2176C/EL2276C are single/dual current-feedback operational amplifiers which achieve a -3 dB bandwidth of 70 MHz at a gain of +1 while consuming only 1 mA of supply current per amplifier. They will operate with dual supplies ranging from $\pm 1.5V$ to $\pm 6V$, or from single supplies ranging from +3V to +12V. The EL2176C/EL2276C also include a disable/power-down feature which reduces current consumption to 0 mA while placing the amplifier output in a high impedance state. In spite of its low supply current, the EL2276C can output 55 mA while swinging to $\pm 4V$ on $\pm 5V$ supplies. The EL2176C can output 100 mA with similar output swings. These attributes make the EL2176C/EL2276C excellent choices for low power and/or low voltage cable-driver, HDSL, or RGB applications.

For Single, Dual and Quad applications without disable, consider the EL2170C (8-Pin Single), EL2270C (8-Pin Dual) or EL2470C (14-Pin Quad). For higher bandwidth applications where low power is still a concern, consider the EL2180C/EL2186C family which also comes in similar Single, Dual and Quad configurations. The EL2180C/EL2186C family provides a -3 dB bandwidth of 250 MHz while consuming 3 mA of supply current per amplifier.

Connection Diagrams

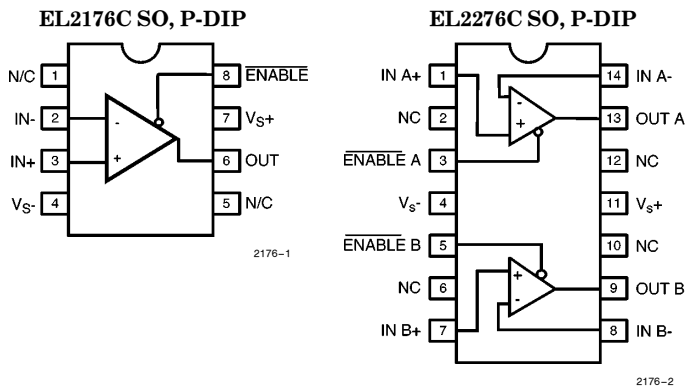

Manufactured under U.S. Patent No. 5,352,989, 5,351,012, 5,418,495

Note: All information contained in this data sheet has been carefully checked and is believed to be accurate as of the date of publication; however, this data sheet cannot be a "controlled document". Current revisions, if any, to these specifications are maintained at the factory and are available upon your request. We recommend checking the revision level before finalization of your design documentation.

EL2176C/EL2276C

70 MHz/1 mA Current Mode Feedback Amp w/Disable

Absolute Maximum Ratings ($T_A = 25^\circ\text{C}$)

Voltage between V_{S+} and V_{S-}	+12.6V	Operating Junction Temperature	
Common-Mode Input Voltage	V_{S-} to V_{S+}	Plastic Packages	150°C
Differential Input Voltage	$\pm 6\text{V}$	Output Current (EL2176C)	$\pm 120\text{ mA}$
Current into +IN or -IN	$\pm 7.5\text{ mA}$	Output Current (EL2276C)	$\pm 60\text{ mA}$
Internal Power Dissipation	See Curves	Storage Temperature Range	-65°C to $+150^\circ\text{C}$
Operating Ambient Temperature Range	-40°C to $+85^\circ\text{C}$		

Important Note:

All parameters having Min/Max specifications are guaranteed. The Test Level column indicates the specific device testing actually performed during production and Quality inspection. Elantec performs most electrical tests using modern high-speed automatic test equipment, specifically the LTX77 Series system. Unless otherwise noted, all tests are pulsed tests, therefore $T_J = T_C = T_A$.

Test Level	Test Procedure
I	100% production tested and QA sample tested per QA test plan QCX0002.
II	100% production tested at $T_A = 25^\circ\text{C}$ and QA sample tested at $T_A = 25^\circ\text{C}$, T_{MAX} and T_{MIN} per QA test plan QCX0002.
III	QA sample tested per QA test plan QCX0002.
IV	Parameter is guaranteed (but not tested) by Design and Characterization Data.
V	Parameter is typical value at $T_A = 25^\circ\text{C}$ for information purposes only.

DC Electrical Characteristics

$V_S = \pm 5\text{V}$, $R_L = 150\Omega$, $\text{ENABLE} = 0\text{V}$, $T_A = 25^\circ\text{C}$ unless otherwise specified

Parameter	Description	Conditions	Min	Typ	Max	Test Level	Units
V_{OS}	Input Offset Voltage			2.5	15	I	mV
TCV_{OS}	Average Input Offset Voltage Drift	Measured from T_{MIN} to T_{MAX}		5		V	$\mu\text{V}/^\circ\text{C}$
dV_{OS}	V_{OS} Matching	EL2276C only		0.5		V	mV
$+I_{IN}$	+ Input Current			0.5	5	I	μA
$d+I_{IN}$	$+I_{IN}$ Matching	EL2276C only		20		V	nA
$-I_{IN}$	- Input Current			4	15	I	μA
$d-I_{IN}$	$-I_{IN}$ Matching	EL2276C only		1.5		V	μA
CMRR	Common Mode Rejection Ratio	$V_{CM} = \pm 3.5\text{ V}$	45	50		I	dB
$-ICMR$	- Input Current Common Mode Rejection	$V_{CM} = \pm 3.5\text{V}$		4	10	I	$\mu\text{A}/\text{V}$
PSRR	Power Supply Rejection Ratio	V_S is moved from $\pm 4\text{V}$ to $\pm 6\text{V}$	60	70		I	dB
$-IPSR$	- Input Current Power Supply Rejection	V_S is moved from $\pm 4\text{V}$ to $\pm 6\text{V}$		0.5	5	I	$\mu\text{A}/\text{V}$
R_{OL}	Transimpedance	$V_{OUT} = \pm 2.5\text{V}$	150	400		I	$\text{k}\Omega$
$+R_{IN}$	+ Input Resistance	$V_{CM} = \pm 3.5\text{V}$	1	4		I	$\text{M}\Omega$
$+C_{IN}$	+ Input Capacitance			1.2		V	pF
CMIR	Common Mode Input Range		± 3.5	± 4.0		I	V

EL2176C/EL2276C

70 MHz/1 mA Current Mode Feedback Amp w/Disable

DC Electrical Characteristics — Contd.

$V_S = \pm 5V$, $R_L = 150\Omega$, $\overline{\text{ENABLE}} = 0V$, $T_A = 25^\circ\text{C}$ unless otherwise specified

Parameter	Description	Conditions	Min	Typ	Max	Test Level	Units
V_O	Output Voltage Swing	$V_S = \pm 5$	± 3.5	± 4.0		I	V
		$V_S = +5$ Single-Supply, High		4.0		V	V
		$V_S = +5$ Single-Supply, Low		0.3		V	V
I_O	Output Current	EL2176C only	80	100		I	mA
		EL2276C only, per Amplifier	50	55		I	mA
I_S	Supply Current	$\overline{\text{ENABLE}} = 2.0V$, per Amplifier		1	2	I	mA
$I_{S(\text{DIS})}$	Supply Current (Disabled)	$\overline{\text{ENABLE}} = 4.5V$		0	20	I	μA
$C_{\text{OUT}(\text{DIS})}$	Output Capacitance (Disabled)	$\overline{\text{ENABLE}} = 4.5V$		4.4		V	pF
R_{EN}	Enable Pin Input Resistance	Measured at $\overline{\text{ENABLE}} = 2.0V, 4.5V$	45	85		I	k Ω
I_{IH}	Logic "1" Input Current	Measured at $\overline{\text{ENABLE}}, \overline{\text{ENABLE}} = 4.5V$		-0.04		V	μA
I_{IL}	Logic "0" Input Current	Measured at $\overline{\text{ENABLE}}, \overline{\text{ENABLE}} = 0V$		-53		V	μA
V_{DIS}	Minimum Voltage at $\overline{\text{ENABLE}}$ to Disable		4.5			I	V
V_{EN}	Maximum Voltage at $\overline{\text{ENABLE}}$ to Enable				2.0	I	V

AC Electrical Characteristics

$V_S = \pm 5V$, $R_F = R_G = 1.0\text{ k}\Omega$, $R_L = 150\Omega$, $\overline{\text{ENABLE}} = 0V$, $T_A = 25^\circ\text{C}$ unless otherwise specified

Parameter	Description	Conditions	Min	Typ	Max	Test Level	Units
-3 dB BW	-3 dB Bandwidth	$A_V = +1$		70		V	MHz
-3 dB BW	-3 dB Bandwidth	$A_V = +2$		60		V	MHz
SR	Slew Rate	$V_{\text{OUT}} = \pm 2.5V$, $A_V = +2$	400	800		IV	V/ μs
t_r, t_f	Rise and Fall Time	$V_{\text{OUT}} = \pm 500\text{ mV}$		4.5		V	ns
t_{pd}	Propagation Delay	$V_{\text{OUT}} = \pm 500\text{ mV}$		4.5		V	ns
OS	Overshoot	$V_{\text{OUT}} = \pm 500\text{ mV}$		3.0		V	%
t_s	0.1% Settling	$V_{\text{OUT}} = \pm 2.5V$, $A_V = -1$		40		V	ns
dG	Differential Gain	$A_V = +2$, $R_L = 150\Omega$ (Note 1)		0.15		V	%
dP	Differential Phase	$A_V = +2$, $R_L = 150\Omega$ (Note 1)		0.15		V	$^\circ$
dG	Differential Gain	$A_V = +1$, $R_L = 500\Omega$ (Note 1)		0.02		V	%
dP	Differential Phase	$A_V = +1$, $R_L = 500\Omega$ (Note 1)		0.01		V	$^\circ$
t_{ON}	Turn-On Time	$A_V = +2$, $V_{\text{IN}} = +1V$, $R_L = 150\Omega$ (Note 2)		40	100	I	ns
t_{OFF}	Turn-Off Time	$A_V = +2$, $V_{\text{IN}} = +1V$, $R_L = 150\Omega$ (Note 2)		1500	2000	I	ns
CS	Channel Separation	EL2276C only, $f = 5\text{ MHz}$		85		V	dB

Note 1: DC offset from 0V to 0.714V, AC amplitude 286 mV_{p,p}, $f = 3.58\text{ MHz}$.

Note 2: Measured from the application of the logic signal until the output voltage is at the 50% point between initial and final values.

EL2176C/EL2276C

70 MHz/1 mA Current Mode Feedback Amp w/Disable

Test Circuit (per Amplifier)

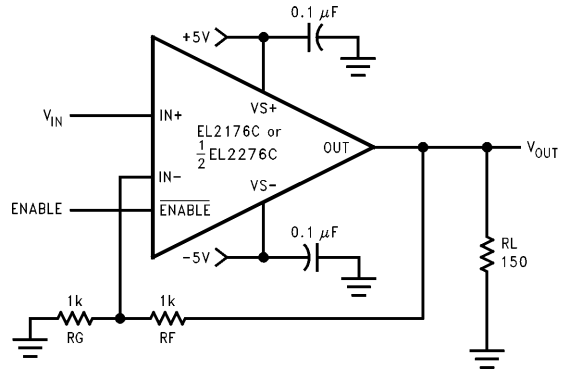

Simplified Schematic (per Amplifier)

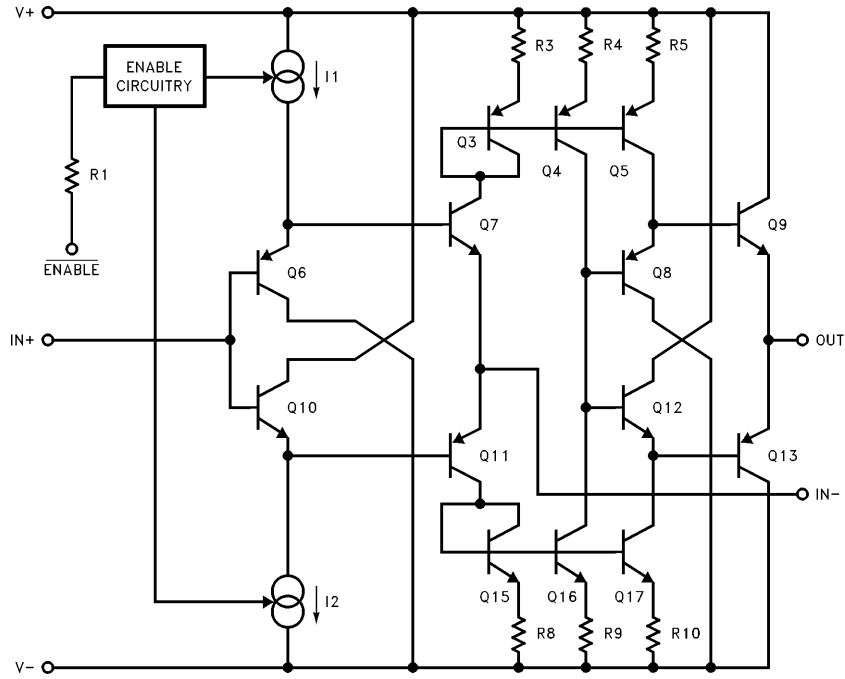

EL2176C/EL2276C

70 MHz/1 mA Current Mode Feedback Amp w/Disable

Typical Performance Curves

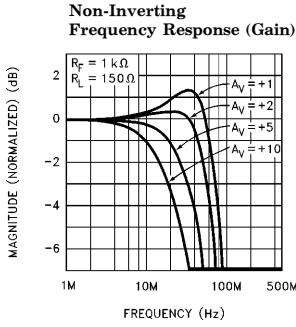

2176-5

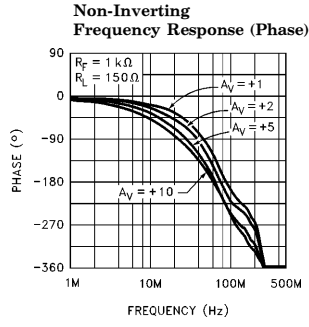

2176-6

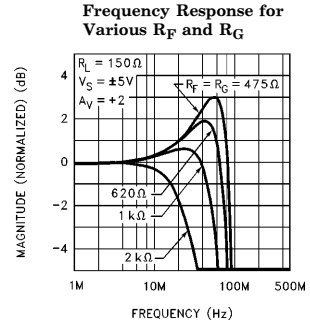

2176-7

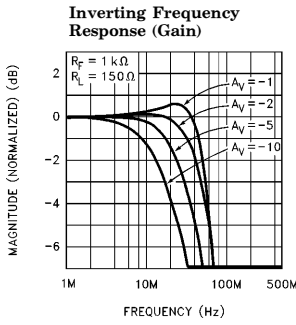

2176-8

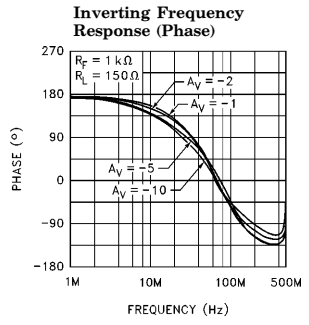

2176-9

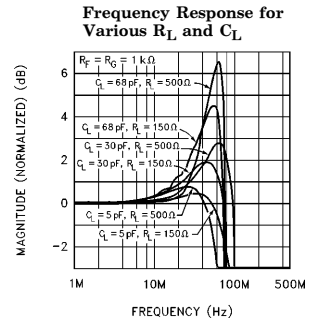

2176-10

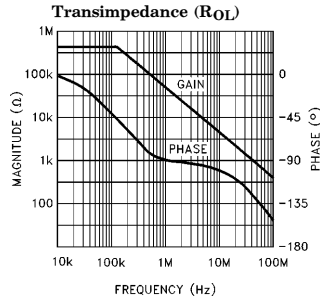

2176-11

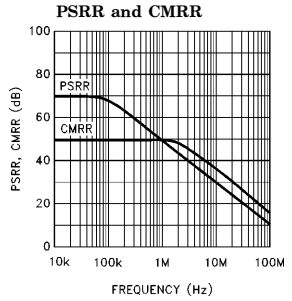

2176-12

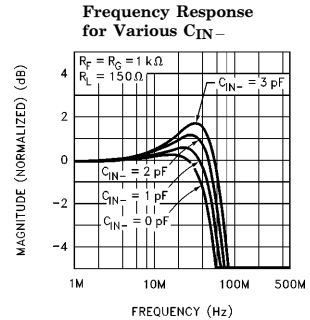

2176-13

EL2176C/EL2276C

70 MHz/1 mA Current Mode Feedback Amp w/Disable

Typical Performance Curves — Contd.

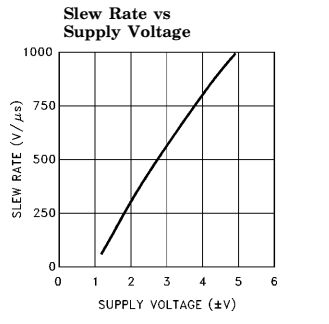
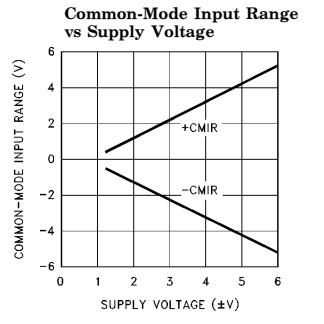
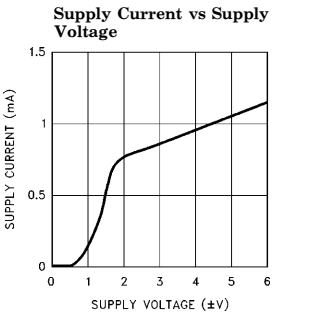
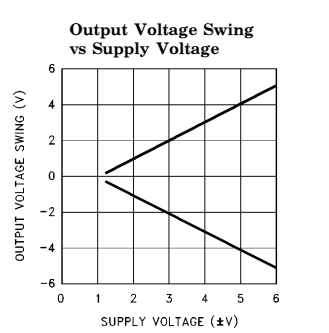
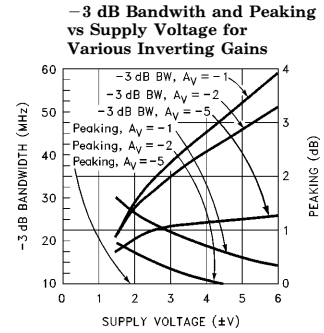
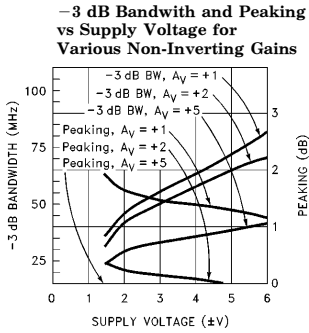
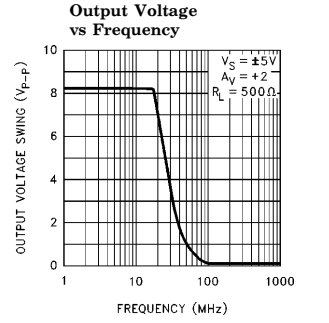
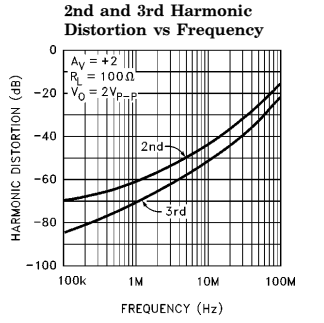
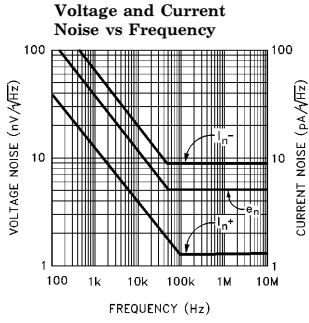

EL2176C/EL2276C

70 MHz/1 mA Current Mode Feedback Amp w/Disable

Typical Performance Curves — Contd.

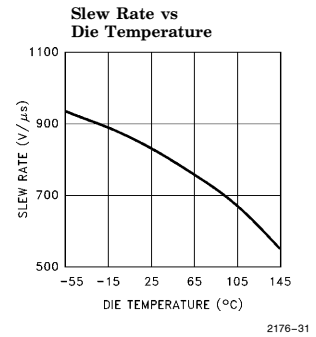
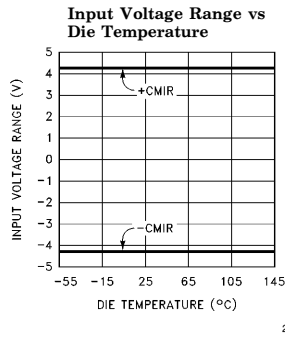
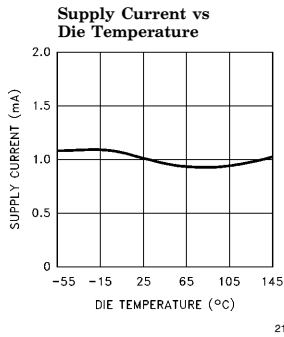
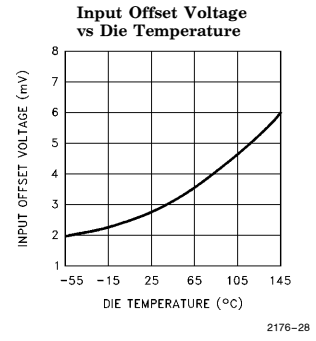
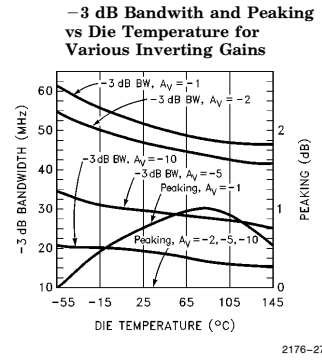
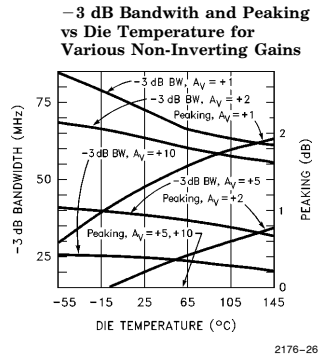
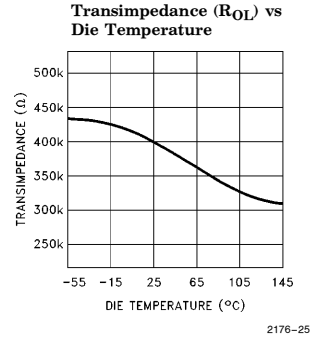
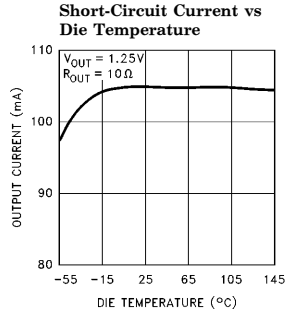
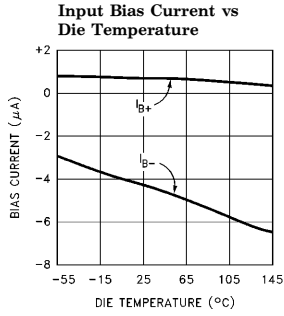

EL2176C/EL2276C

70 MHz/1 mA Current Mode Feedback Amp w/Disable

Typical Performance Curves — Contd.

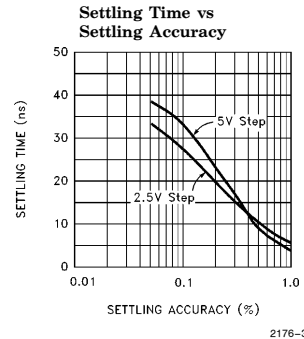
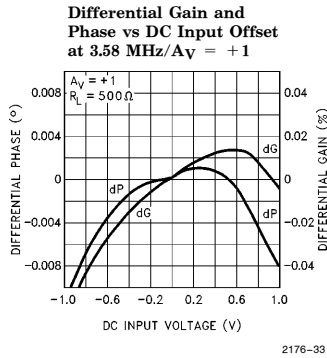
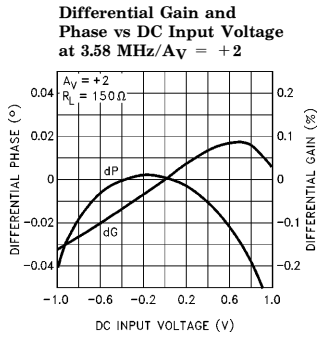

Small-Signal Step Response

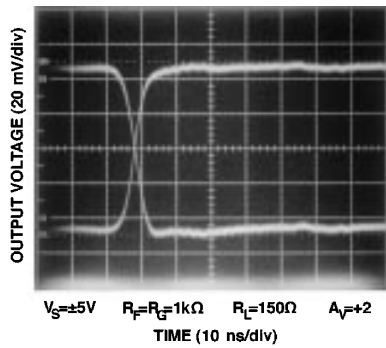

Large-Signal Step Response

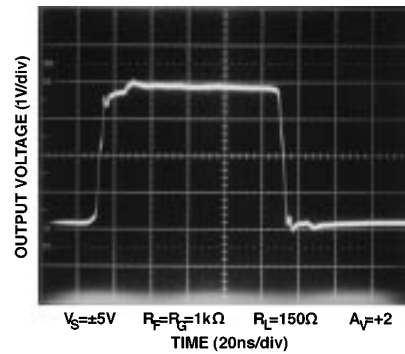

8-Pin Plastic DIP Maximum Power Dissipation vs Ambient Temperature

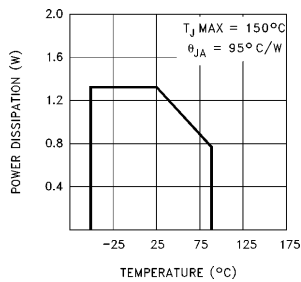

8-Lead SO Maximum Power Dissipation vs Ambient Temperature

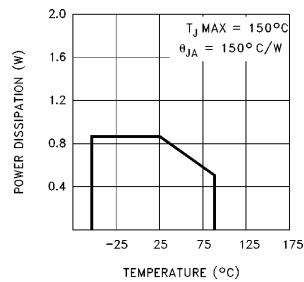

EL2176C/EL2276C

70 MHz/1 mA Current Mode Feedback Amp w/Disable

Typical Performance Curves — Contd.

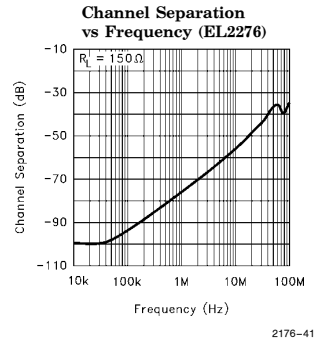
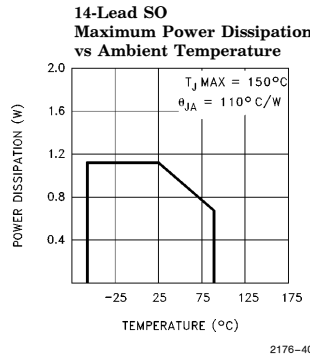
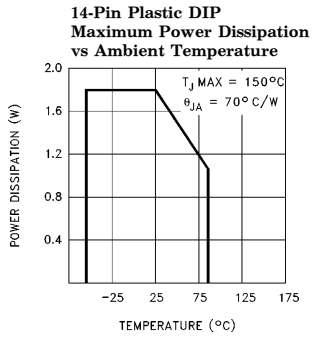

EL2176C/EL2276C

70 MHz/1 mA Current Mode Feedback Amp w/Disable

Applications Information

Product Description

The EL2176C/EL2276C are current-feedback operational amplifiers that offer a wide -3 dB bandwidth of 70 MHz, a low supply current of 1 mA per amplifier and the ability to disable to 0 mA. Both products also feature high output current drive. The EL2176C can output 100 mA, while the EL2276C can output 55 mA per amplifier. The EL2176C/EL2276C work with supply voltages ranging from a single 3V to ± 6 V, and they are also capable of swinging to within 1V of either supply on the input and the output. Because of their current-feedback topology, the EL2176C/EL2276C do not have the normal gain-bandwidth product associated with voltage-feedback operational amplifiers. This allows their -3 dB bandwidth to remain relatively constant as closed-loop gain is increased. This combination of high bandwidth and low power, together with aggressive pricing make the EL2176C/EL2276C the ideal choice for many low-power/high-bandwidth applications such as portable computing, HDSL, and video processing.

For Single, Dual and Quad applications without disable, consider the EL2170C (8-Pin Single), EL2270C (8-Pin Dual) and EL2470C (14-Pin Quad). If more AC performance is required, refer to the EL2180C/EL2186C family which provides Singles, Duals, and Quads with 250 MHz of bandwidth while consuming 3 mA of supply current per amplifier.

Power Supply Bypassing and Printed Circuit Board Layout

As with any high-frequency device, good printed circuit board layout is necessary for optimum performance. Ground plane construction is highly recommended. Lead lengths should be as short as possible. The power supply pins must be well bypassed to reduce the risk of oscillation. The combination of a 4.7 μ F tantalum capacitor in parallel with a 0.1 μ F capacitor has been shown to work well when placed at each supply pin.

For good AC performance, parasitic capacitance should be kept to a minimum especially at the inverting input (see the Capacitance at the Inverting Input section). Ground plane construc-

tion should be used, but it should be removed from the area near the inverting input to minimize any stray capacitance at that node. Carbon or Metal-Film resistors are acceptable with the Metal-Film resistors giving slightly less peaking and bandwidth because of their additional series inductance. Use of sockets, particularly for the SO package should be avoided if possible. Sockets add parasitic inductance and capacitance which will result in some additional peaking and overshoot.

Disable/Power-Down

The EL2176C/EL2276C amplifiers can be disabled, placing their output in a high-impedance state. When disabled, each amplifier's supply current is reduced to 0 mA. Each EL2176C/EL2276C amplifier is disabled when its ENABLE pin is floating or pulled up to within 0.5V of the positive supply. Similarly, each amplifier is enabled by pulling its ENABLE pin at least 3V below the positive supply. For ± 5 V supplies, this means that an EL2176C/EL2276C amplifier will be enabled when ENABLE is at 2V or less, and disabled when ENABLE is above 4.5V. Although the logic levels are not standard TTL, this choice of logic voltages allows the EL2176C/EL2276C to be enabled by tying ENABLE to ground, even in +3V single-supply applications. The ENABLE pin can be driven from CMOS outputs or open-collector TTL.

When enabled, supply current does vary somewhat with the voltage applied at ENABLE. For example, with the supply voltages of the EL2176C at ± 5 V, if ENABLE is tied to -5 V (rather than ground) the supply current will increase about 15% to 1.15 mA.

Capacitance at the Inverting Input

Any manufacturer's high-speed voltage- or current-feedback amplifier can be affected by stray capacitance at the inverting input. For inverting gains this parasitic capacitance has little effect because the inverting input is a virtual ground, but for non-inverting gains this capacitance (in conjunction with the feedback and gain resistors) creates a pole in the feedback path of the amplifier. This pole, if low enough in frequency, has the same destabilizing effect as a zero in the forward open-loop response. The use of large value feed-

EL2176C/EL2276C

70 MHz/1 mA Current Mode Feedback Amp w/Disable

Applications Information — Contd.
back and gain resistors further exacerbates the problem by further lowering the pole frequency.

The EL2176C/EL2276C have been specially designed to reduce power dissipation in the feedback network by using large 1.0 k Ω feedback and gain resistors. With the high bandwidths of these amplifiers, these large resistor values would normally cause stability problems when combined with parasitic capacitance, but by internally canceling the effects of a nominal amount of parasitic capacitance, the EL2176C/EL2276C remain very stable. For less experienced users, this feature makes the EL2176C/EL2276C much more forgiving, and therefore easier to use than other products not incorporating this proprietary circuitry.

The experienced user with a large amount of PC board layout experience may find in rare cases that the EL2176C/EL2276C have less bandwidth than expected. In this case, the inverting input may have less parasitic capacitance than expected by the internal compensation circuitry of the EL2176C/EL2276C. The reduction of feedback resistor values (or the addition of a very small amount of external capacitance at the inverting input, e.g., 0.5 pF) will increase bandwidth as desired. Please see the curves for Frequency Response for Various R_F and R_G, and Frequency Response for Various C_{IN}—.

Feedback Resistor Values

The EL2176C/EL2276C have been designed and specified at gains of +1 and +2 with R_F = 1.0 k Ω . This value of feedback resistor gives 70 MHz of -3 dB bandwidth at A_V = +1 with about 1.5 dB of peaking, and 60 MHz of -3 dB bandwidth at A_V = +2 with about 0.5 dB of peaking. Since the EL2176C/EL2276C are current-feedback amplifiers, it is also possible to change the value of R_F to get more bandwidth. As seen in the curve of Frequency Response For Various R_F and R_G, bandwidth and peaking can be easily modified by varying the value of the feedback resistor.

Because the EL2176C is a current-feedback amplifier, the gain-bandwidth product is not a constant for different closed-loop gains. This feature

actually allows the EL2176C/EL2276C to maintain about the same -3 dB bandwidth, regardless of closed-loop gain. However, as closed-loop gain is increased, bandwidth decreases slightly while stability increases.

Since the loop stability is improving with higher closed-loop gains, it becomes possible to reduce the value of R_F below the specified 1.0 k Ω and still retain stability, resulting in only a slight loss of bandwidth with increased closed-loop gain.

Supply Voltage Range and Single-Supply Operation

The EL2176C/EL2276C have been designed to operate with supply voltages having a span of greater than 3V, and less than 12V. In practical terms, this means that the EL2176C/EL2276C will operate on dual supplies ranging from $\pm 1.5V$ to $\pm 6V$. With a single-supply, the EL2176C will operate from +3V to +12V.

As supply voltages continue to decrease, it becomes necessary to provide input and output voltage ranges that can get as close as possible to the supply voltages. The EL2176C/EL2276C have an input voltage range that extends to within 1V of either supply. So, for example, on a single +5V supply, the EL2176C/EL2276C have an input range which spans from 1V to 4V. The output range of the EL2176C/EL2276C is also quite large, extending to within 1V of the supply rail. On a $\pm 5V$ supply, the output is therefore capable of swinging from -4V to +4V. Single-supply output range is even larger because of the increased negative swing due to the external pull-down resistor to ground. On a single +5V supply, output voltage range is about 0.3V to 4V.

Video Performance

For good video performance, an amplifier is required to maintain the same output impedance and the same frequency response as DC levels are changed at the output. This is especially difficult when driving a standard video load of 150 Ω , because of the change in output current with DC level. Until the EL2176C/EL2276C, good Differential Gain could only be achieved by running high idle currents through the output transistors (to reduce variations in output impedance). These currents were typically in excess of the

EL2176C/EL2276C

70 MHz/1 mA Current Mode Feedback Amp w/Disable

Applications Information — Contd.

entire 1 mA supply current of each EL2176C/EL2276C amplifier! Special circuitry has been incorporated in the EL2176C/EL2276C to reduce the variation of output impedance with current output. This results in dG and dP specifications of 0.15% and 0.15° while driving 150Ω at a gain of +2.

Video Performance has also been measured with a 500Ω load at a gain of +1. Under these conditions, the EL2176C/EL2276C have dG and dP specifications of 0.01% and 0.02° respectively while driving 500Ω at $A_V = +1$.

Output Drive Capability

In spite of its low 1 mA of supply current, the EL2176C is capable of providing a minimum of ±80 mA of output current. Similarly, each amplifier of the EL2276C is capable of providing a minimum of ±50 mA. These output drive levels are unprecedented in amplifiers running at these supply currents. With a minimum ±80 mA of output drive, the EL2176C is capable of driving 50Ω loads to ±4V, making it an excellent choice for driving isolation transformers in telecommunications applications. Similarly, the ±50 mA minimum output drive of each EL2276C amplifier allows swings of ±2.5V into 50Ω loads.

Driving Cables and Capacitive Loads

When used as a cable driver, double termination is always recommended for reflection-free performance. For those applications, the back-termination series resistor will decouple the EL2176C/EL2276C from the cable and allow extensive capacitive drive. However, other applications may have high capacitive loads without a back-termination resistor. In these applications, a small series resistor (usually between 5Ω and 50Ω) can be placed in series with the output to eliminate most peaking. The gain resistor (R_G) can then be chosen to make up for any gain loss which may be created by this additional resistor at the output. In many cases it is also possible to simply increase the value of the feedback resistor (R_F) to reduce the peaking.

Current Limiting

The EL2176C/EL2276C have no internal current-limiting circuitry. If any output is shorted, it is possible to exceed the Absolute Maximum Ratings for output current or power dissipation, potentially resulting in the destruction of the device.

Power Dissipation

With the high output drive capability of the EL2176C/EL2276C, it is possible to exceed the 150°C Absolute Maximum junction temperature under certain very high load current conditions. Generally speaking, when R_L falls below about 25Ω, it is important to calculate the maximum junction temperature (T_{Jmax}) for the application to determine if power-supply voltages, load conditions, or package type need to be modified for the EL2176C/EL2276C to remain in the safe operating area. These parameters are calculated as follows:

$$T_{JMAX} = T_{MAX} + (\theta_{JA} * n * PD_{MAX}) \quad [1]$$

where:

T_{MAX} = Maximum Ambient Temperature

θ_{JA} = Thermal Resistance of the Package

n = Number of Amplifiers in the Package

PD_{MAX} = Maximum Power Dissipation of Each Amplifier in the Package.

PD_{MAX} for each amplifier can be calculated as follows:

$$PD_{MAX} = (2 * V_S * I_{SMAX}) + (V_S - V_{OUTMAX}) * (V_{OUTMAX}/R_L) \quad [2]$$

where:

V_S = Supply Voltage

I_{SMAX} = Maximum Supply Current of 1 Amplifier

V_{OUTMAX} = Max. Output Voltage of the Application

R_L = Load Resistance

EL2176C/EL2276C

70 MHz/1 mA Current Mode Feedback Amp w/Disable

Typical Application Circuits

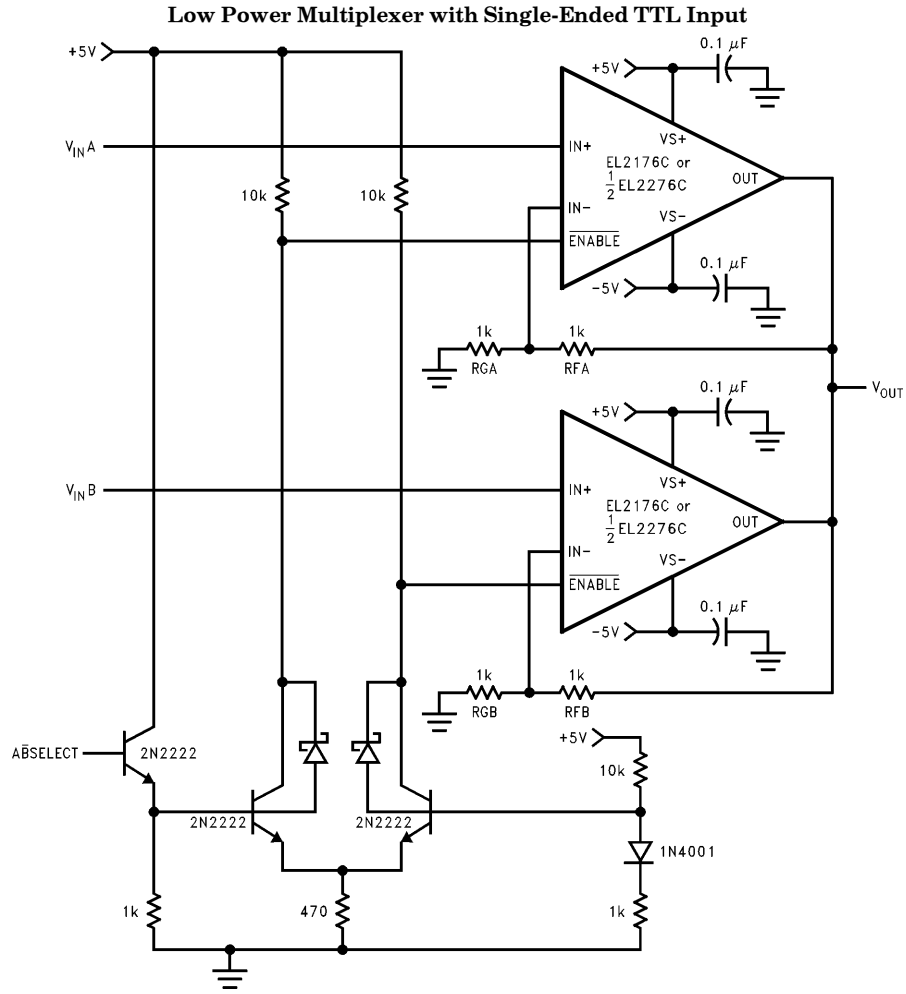

2176-42

EL2176C/EL2276C

70 MHz/1 mA Current Mode Feedback Amp w/Disable

Typical Application Circuits — Contd.

Inverting 200 mA Output Current Distribution Amplifier

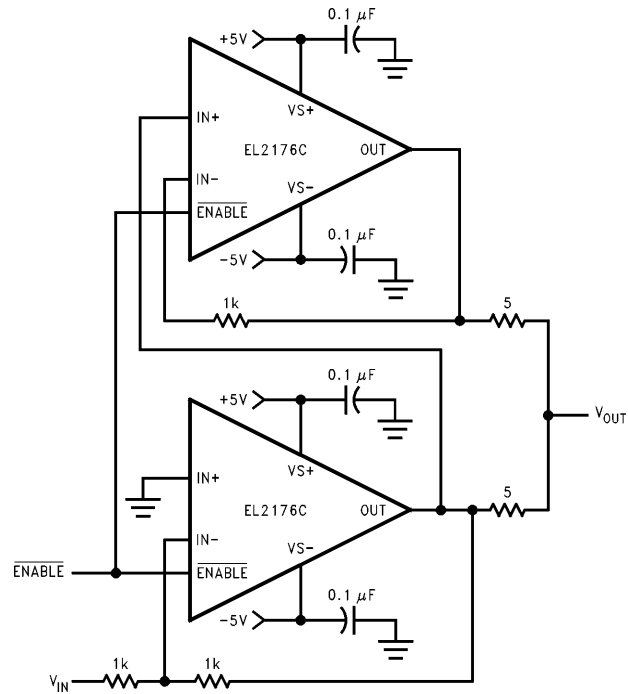

2176-43

EL2176C/EL2276C

70 MHz/1 mA Current Mode Feedback Amp w/Disable

Typical Application Circuits — Contd.

Differential Line-Driver/Receiver

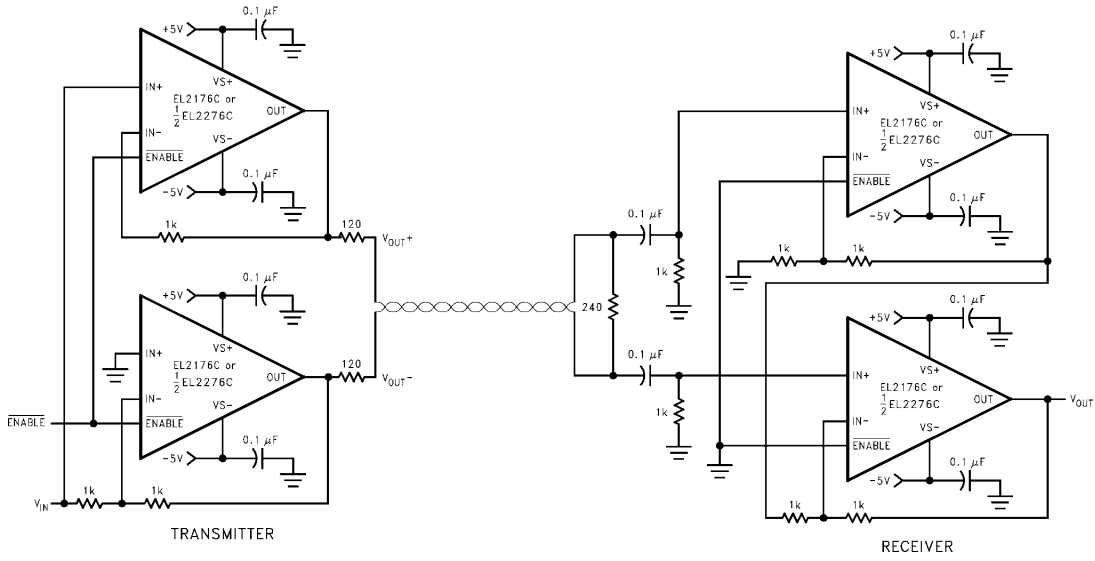

2176-44

EL2176C/EL2276C

70 MHz/1 mA Current Mode Feedback Amp w/Disable

Typical Application Circuits — Contd.

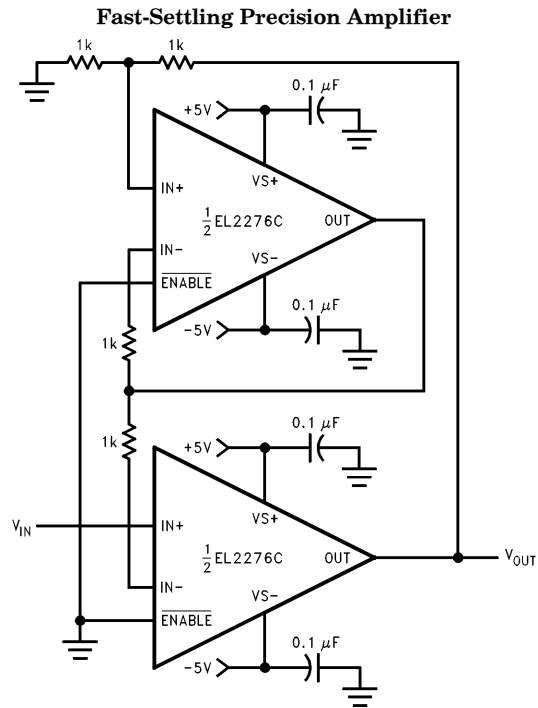

2176-45

EL2176C/EL2276C

70 MHz/1 mA Current Mode Feedback Amp w/Disable

EL2176C/EL2276C Macromodel

* Revision A, March 1995

* AC characteristics used $R_f = R_g = 1K\Omega$, $R_L = 150\Omega$

* Connections:

+ input					
	- input		+ Vsupply	- Vsupply	output

.subckt EL2176/el 3 2 7 4 6

* Input Stage

e1 10 0 3 0 1.0
 vis 10 9 0V
 h2 9 12 vxx 1.0
 r1 2 11 165
 l1 11 12 25nH
 iinp 3 0 0.5uA
 iinm 2 0 4uA
 r12 3 0 4Meg

* Slew Rate Limiting

h1 13 0 vis 600
 r2 13 14 1K
 d1 14 0 dclamp
 d2 0 14 dclamp

* High Frequency Pole

e2 30 0 14 0 0.001666666666
 l3 30 17 0.5uH
 c5 17 0 0.69pF
 r5 17 0 300

* Transimpedance Stage

g1 0 18 17 0 1.0
 rol 18 0 400K
 cdp 18 0 1.9pF

* Output Stage

q1 4 18 19 qp
 q2 7 18 20 qn
 q3 7 19 21 qn
 q4 4 20 22 qp
 r7 21 6 4
 r8 22 6 4
 ios1 7 19 0.4mA
 ios2 20 4 0.4mA

* Supply Current

ips 7 4 1nA

* Error Terms

ivos 0 23 2mA
 vxx 23 0 0V
 e4 24 0 3 0 1.0
 e5 25 0 7 0 1.0
 e6 26 0 4 0 -1.0
 r9 24 23 0.316K
 r10 25 23 3.2K
 r11 26 23 3.2K

* Models

.model qn npn(is = 5e-15 bf = 200 tf = 0.01nS)
 .model qp pnp(is = 5e-15 bf = 200 tf = 0.01nS)
 .model dclamp d(is = 1e-30 ibv = 0.266
 + bv = 1.3v n = 4)
 .ends

EL2176C/EL2276C

70 MHz/1 mA Current Mode Feedback Amp w/Disable

EL2176C/EL2276C Macromodel — Contd.

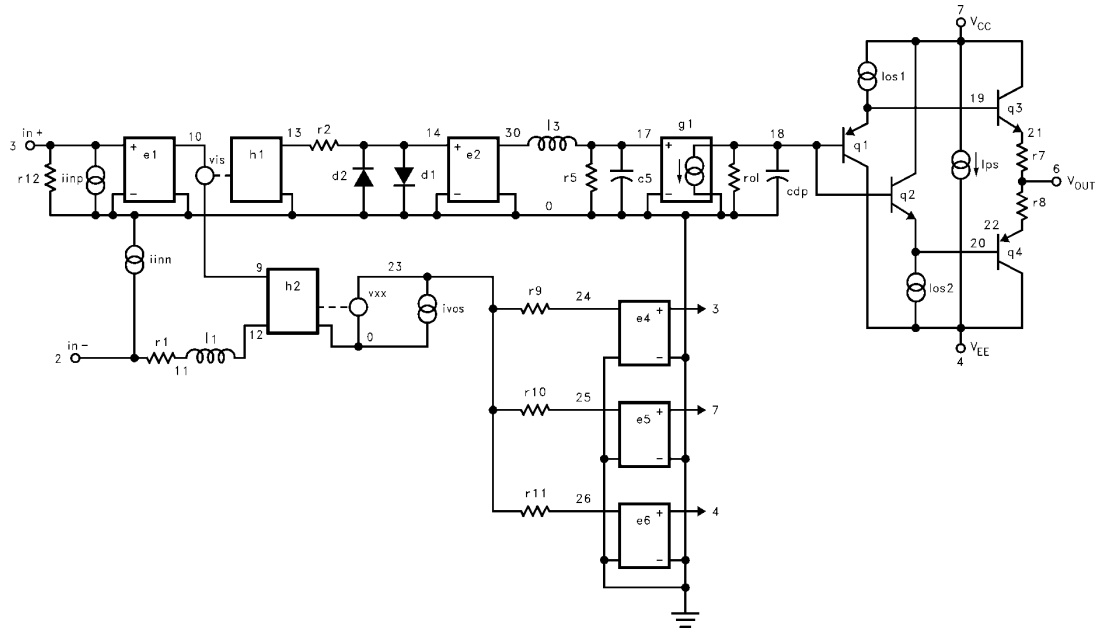

2176-46

BLANK

EL2176C/EL2276C

70 MHz/1 mA Current Mode Feedback Amp w/Disable

General Disclaimer

Specifications contained in this data sheet are in effect as of the publication date shown. Elantec, Inc. reserves the right to make changes in the circuitry or specifications contained herein at any time without notice. Elantec, Inc. assumes no responsibility for the use of any circuits described herein and makes no representations that they are free from patent infringement.



Elantec, Inc.

1996 Tarob Court

Milpitas, CA 95035

Telephone: (408) 945-1323

(800) 333-6314

Fax: (408) 945-9305

European Office: 44-71-482-4596

WARNING — Life Support Policy

Elantec, Inc. products are not authorized for and should not be used within Life Support Systems without the specific written consent of Elantec, Inc. Life Support systems are equipment intended to support or sustain life and whose failure to perform when properly used in accordance with instructions provided can be reasonably expected to result in significant personal injury or death. Users contemplating application of Elantec, Inc. products in Life Support Systems are requested to contact Elantec, Inc. factory headquarters to establish suitable terms & conditions for these applications. Elantec, Inc.'s warranty is limited to replacement of defective components and does not cover injury to persons or property or other consequential damages.