

## 1 Mb (64K x 16) UV EPROM and OTP EPROM

### DATA BRIEFING

- 5V ± 10% SUPPLY VOLTAGE in READ OPERATION
- FAST ACCESS TIME: 35ns
- LOW POWER CONSUMPTION:
  - Active Current 35mA
  - Standby Current 100µA
- PROGRAMMING VOLTAGE: 12.75V ± 0.25V
- PROGRAMMING TIME of AROUND 6 sec. (PRESTO II Algorithm)
- ELECTRONIC SIGNATURE
  - Manufacturer Code: 0020h
  - Device Code: 008Ch

### DESCRIPTION

The M27C1024 is a 1 Mb EPROM offered in the two ranges UV (ultra violet erase) and OTP (one time programmable). It is ideally suited for micro-processor systems requiring large data or program storage. It is organized as 65,536 words by 16 bits.

The FDIP40W (window ceramic frit-seal package) has a transparent lid which allows the user to expose the chip to ultraviolet light to erase the bit pattern. A new pattern can then be written to the device by following the programming procedure.

For application where the content is programmed only one time and erasure is not required, the M27C1024 is offered in PLCC44 and TSOP40 (10 x 14mm) packages.

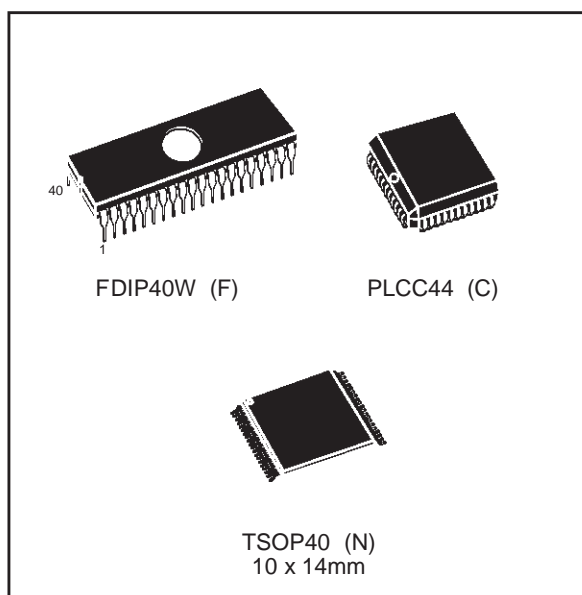

### Logic Diagram

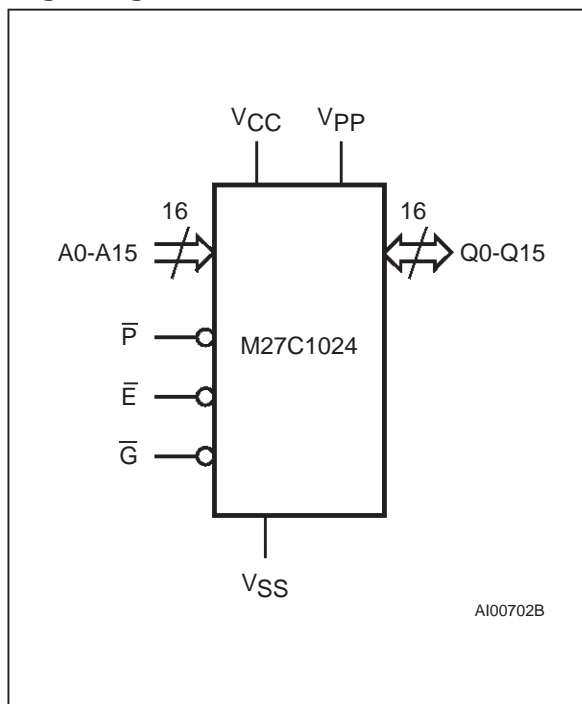

# M27C1024

## DIP Pin Connections

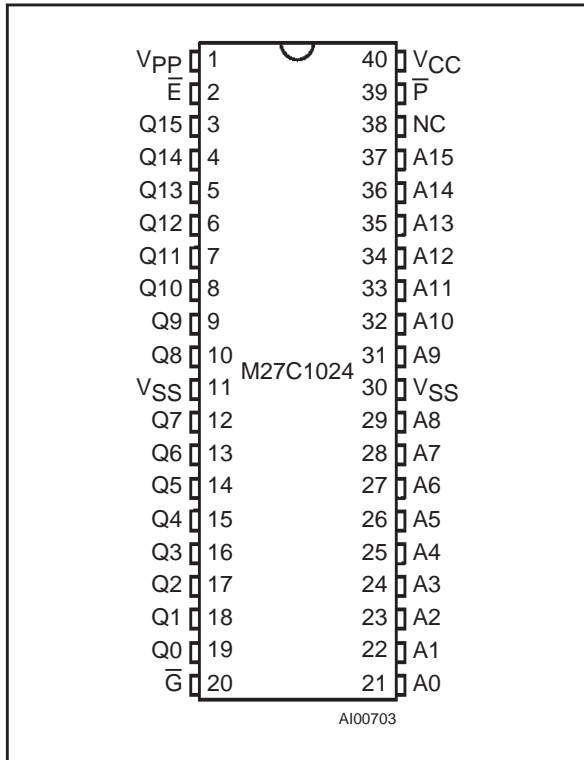

Warning: NC = Not Connected.

## LCC Pin Connections

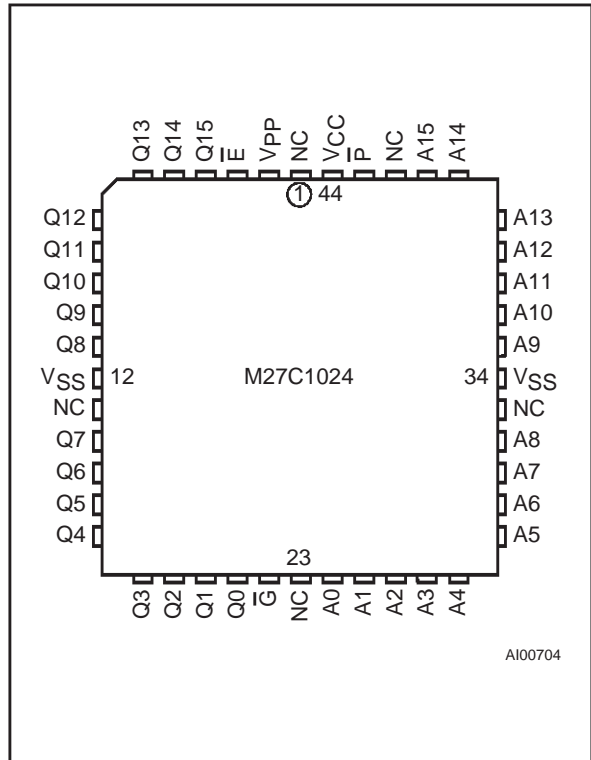

Warning: NC = Not Connected.

## TSOP Pin Connections

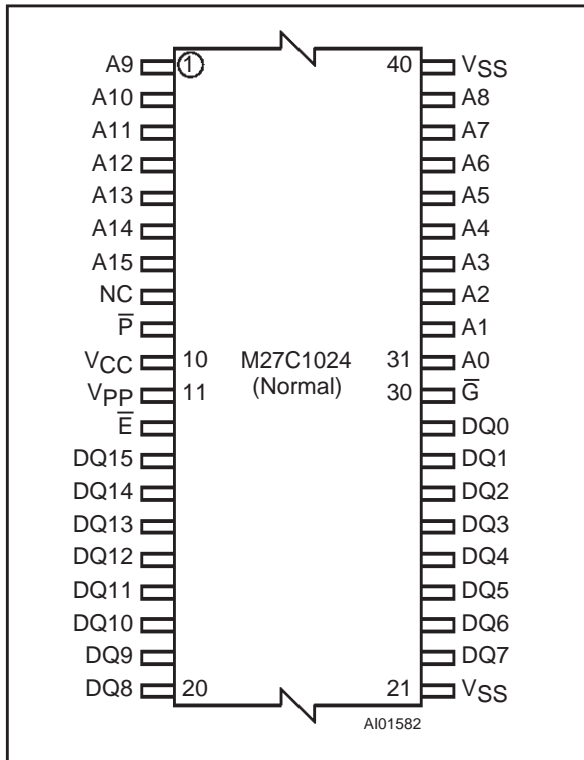

Warning: NC = Not Connected.

## Signal Names

A0-A15	Address Inputs
Q0-Q15	Data Outputs
$\bar{E}$	Chip Enable
$\bar{G}$	Output Enable
$\bar{P}$	Program
V <sub>PP</sub>	Program Supply
V <sub>CC</sub>	Supply Voltage
V <sub>SS</sub>	Ground

## ORDERING INFORMATION SCHEME

Example: M27C1024 -12 X C 1 X

Speed		V <sub>CC</sub> Tolerance		Package		Temperature Range		Option	
-35 <sup>(1)</sup>	35ns	X	± 5%	F	FDIP40W	1	0 to 70 °C	X	Additional Burn-in
-45 <sup>(1)</sup>	45ns	blank	± 10%	C	PLCC44	6	-40 to 85 °C	TR	Tape & Reel Packing
-60	60ns			N	TSOP40 10 x 14mm	7	-40 to 105 °C		
-70	70ns					3	-40 to 125 °C		
-80	80ns								
-10	100ns								
-12	120ns								
-15	150ns								
-20	200ns								

**Note:** 1. High Speed, see AC Characteristics section for further information.

For a list of available options (Speed, Package, etc...) or for further information on any aspect of this device, please contact the SGS-THOMSON Sales Office nearest to you.