

6-PIN DIP ZERO-CROSS OPTOISOLATORS TRIAC DRIVER OUTPUT (250/400 VOLT PEAK)

MOC3031M

MOC3032M

MOC3033M

MOC3041M

MOC3042M

MOC3043M

DESCRIPTION

The MOC303XM and MOC304XM devices consist of a AlGaAs infrared emitting diode optically coupled to a monolithic silicon detector performing the function of a zero voltage crossing bilateral triac driver.

They are designed for use with a triac in the interface of logic systems to equipment powered from 115 VAC lines, such as teletypewriters, CRTs, solid-state relays, industrial controls, printers, motors, solenoids and consumer appliances, etc.

FEATURES

- Simplifies logic control of 115 VAC power
- Zero voltage crossing
- dv/dt of 2000 V/ μ s typical, 1000 V/ μ s guaranteed
- VDE recognized (File # 94766)
- ordering option V (e.g., MOC3043VM)

APPLICATIONS

- Solenoid/valve controls
- Static power switches
- Temperature controls
- AC motor starters
- Lighting controls
- AC motor drives
- E.M. contactors
- Solid state relays

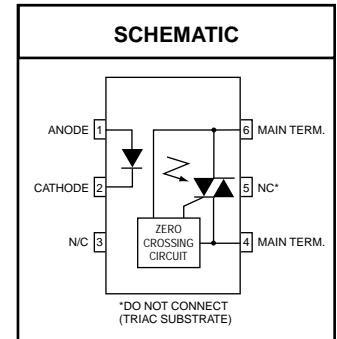
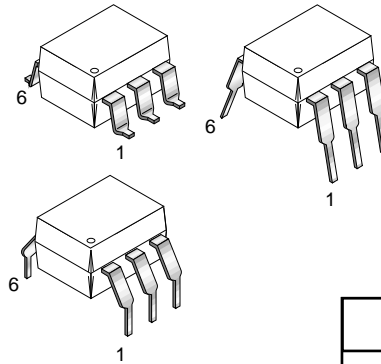

ABSOLUTE MAXIMUM RATINGS ($T_A = 25^\circ\text{C}$ unless otherwise noted)

Parameters	Symbol	Device	Value	Units
TOTAL DEVICE				
Storage Temperature	T_{STG}	All	-40 to +150	$^\circ\text{C}$
Operating Temperature	T_{OPR}	All	-40 to +85	$^\circ\text{C}$
Lead Solder Temperature	T_{SOL}	All	260 for 10 sec	$^\circ\text{C}$
Junction Temperature Range	T_J	All	-40 to +100	$^\circ\text{C}$
Isolation Surge Voltage ⁽¹⁾ (peak AC voltage, 60Hz, 1 sec duration)	V_{ISO}	All	7500	Vac(pk)
Total Device Power Dissipation @ 25°C Derate above 25°C	P_D	All	250	mW
			2.94	mW/ $^\circ\text{C}$
EMITTER				
Continuous Forward Current	I_F	All	60	mA
Reverse Voltage	V_R	All	6	V
Total Power Dissipation 25°C Ambient Derate above 25°C	P_D	All	120	mW
			1.41	mW/ $^\circ\text{C}$
DETECTOR				
Off-State Output Terminal Voltage	V_{DRM}	MOC3031M/2M/3M	250	V
		MOC3041M/2M/3M	400	
Peak Repetitive Surge Current (PW = 100 μ s, 120 pps)	I_{TSM}	All	1	A
Total Power Dissipation @ 25°C Ambient Derate above 25°C	P_D	All	150	mW
		All	1.76	mW/ $^\circ\text{C}$

Note
1. Isolation surge voltage, V_{ISO} , is an internal device dielectric breakdown rating. For this test, Pins 1 and 2 are common, and Pins 4, 5 and 6 are common.

6-PIN DIP ZERO-CROSS OPTOISOLATORS TRIAC DRIVER OUTPUT (250/400 VOLT PEAK)

MOC3031M MOC3032M MOC3033M MOC3041M MOC3042M MOC3043M

ELECTRICAL CHARACTERISTICS (T_A = 25°C Unless otherwise specified)

INDIVIDUAL COMPONENT CHARACTERISTICS

Parameters	Test Conditions	Symbol	Device	Min	Typ	Max	Units
EMITTER							
Input Forward Voltage	I _F = 30 mA	V _F	All		1.25	1.5	V
Reverse Leakage Current	V _R = 6 V	I _R	All		0.01	100	μA
DETECTOR							
Peak Blocking Current, Either Direction	Rated V _{DRM} , I _F = 0 (note 1)	I _{DRM1}	All			100	nA
Peak On-State Voltage, Either Direction	I _{TM} = 100 mA peak, I _F = 0	V _{TM}	All		1.8	3	V
Critical Rate of Rise of Off-State Voltage	I _F = 0 (figure 9, note 3)	dv/dt	All	1000			V/μs

TRANSFER CHARACTERISTICS (T_A = 25°C Unless otherwise specified.)

DC Characteristics	Test Conditions	Symbol	Device	Min	Typ	Max	Units
LED Trigger Current	Main terminal voltage = 3V (note 2)	I _{FT}	MOC3031M/MOC3041M			15	mA
			MOC3032M/MOC3042M			10	
			MOC3033M/MOC3043M			5	
Holding Current, Either Direction		I _H	All		400		μA

ZERO CROSSING CHARACTERISTICS (T_A = 25°C Unless otherwise specified.)

Characteristics	Test Conditions	Symbol	Device	Min	Typ	Max	Units
Inhibit Voltage	I _F = rated I _{FT} , MT1-MT2 voltage above which device will not trigger off-state	V _{IH}	All			20	V
Leakage in Inhibited State	I _F = rated I _F , rated V _{DRM} , off-state	I _{DRM2}	All			500	μA

- Note
1. Test voltage must be applied within dv/dt rating.
 2. All devices are guaranteed to trigger at an I_F value less than or equal to max I_{FT}. Therefore, recommended operating I_F lies between max I_{FT} (15 mA for MOC3031M & MOC3041M, 10 mA for MOC3032M & MOC3042M, 5 mA for MOC3033M & MOC3043M) and absolute max I_F (60 mA).
 3. This is static dv/dt. See Figure 9 for test circuit. Commutating dv/dt is a function of the load-driving thyristor(s) only.

6-PIN DIP ZERO-CROSS OPTOISOLATORS TRIAC DRIVER OUTPUT (250/400 VOLT PEAK)

MOC3031M

MOC3032M

MOC3033M

MOC3041M

MOC3042M

MOC3043M

Figure 1. LED Forward Voltage vs. Forward Current

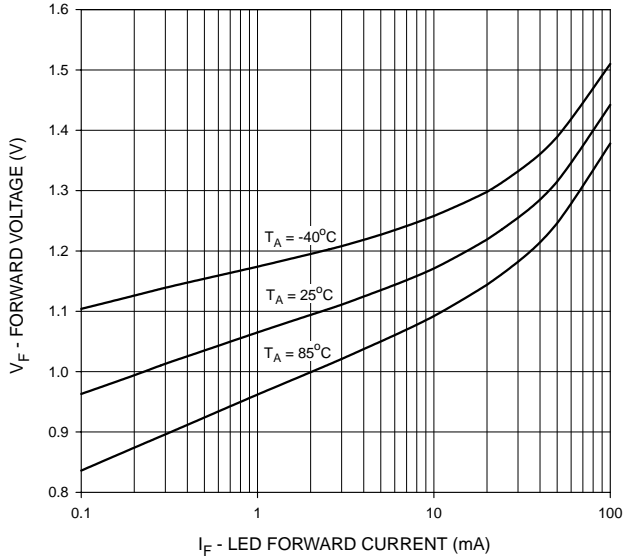

Figure 2. On-State Characteristics

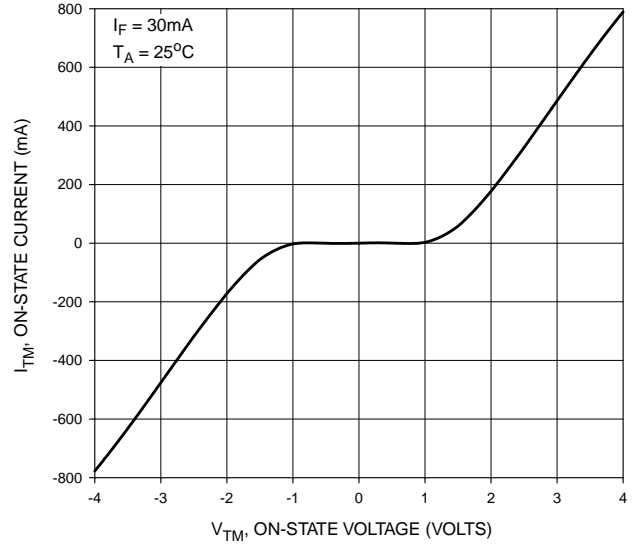

Figure 3. Trigger Current vs. Temperature

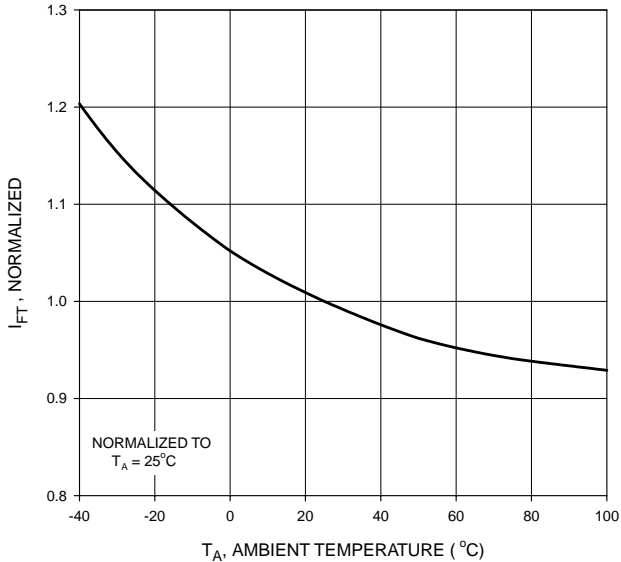
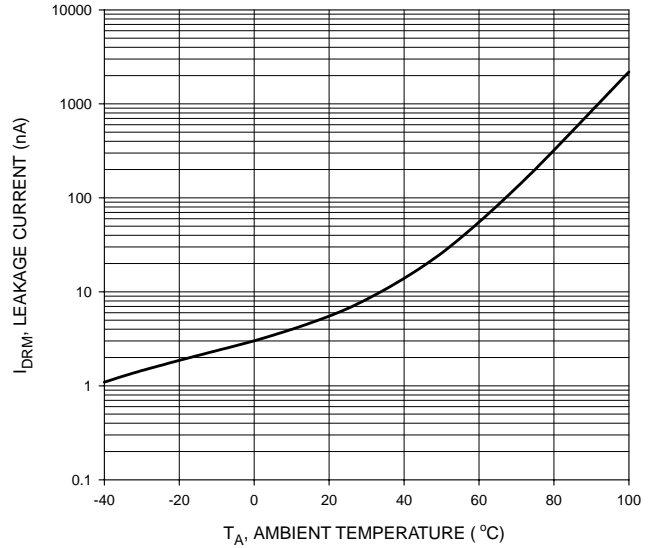

Figure 4. Leakage Current, I_{DRM} vs. Temperature



6-PIN DIP ZERO-CROSS OPTOISOLATORS TRIAC DRIVER OUTPUT (250/400 VOLT PEAK)

MOC3031M

MOC3032M

MOC3033M

MOC3041M

MOC3042M

MOC3043M

Figure 5. I_{DRM2} - Leakage in Inhibit State vs. Temperature

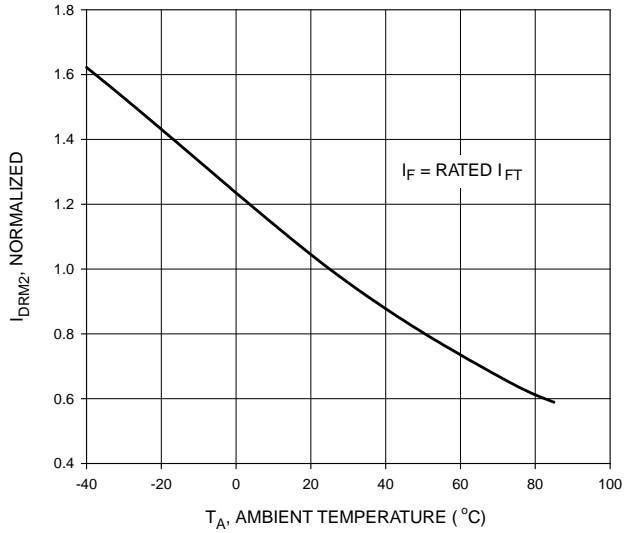

Figure 6. LED Current Required to Trigger vs. LED Pulse Width

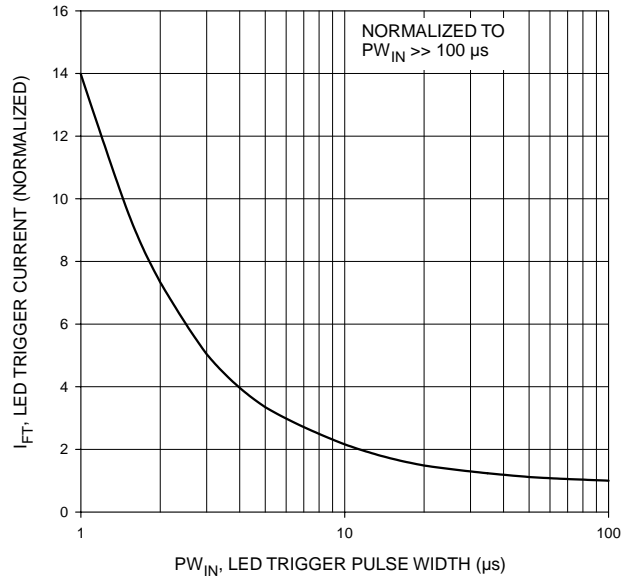

Figure 7. Holding Current, I_H vs. Temperature

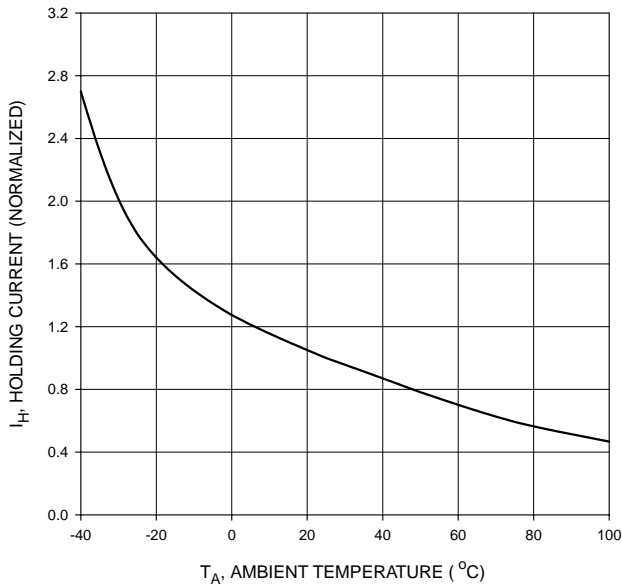
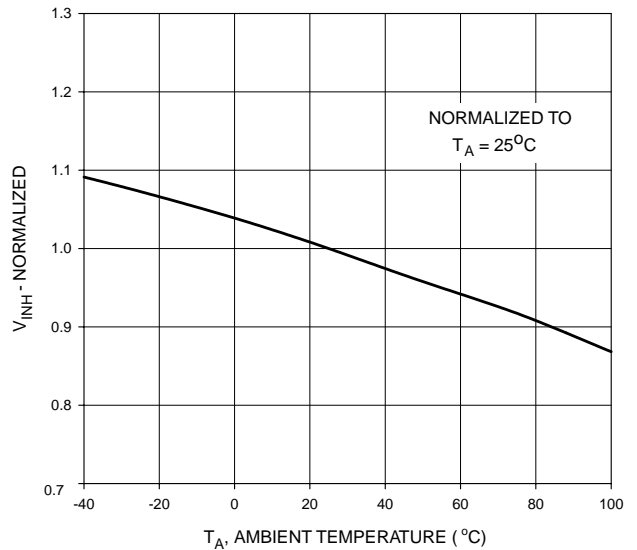

Figure 8. Inhibit Voltage vs. Temperature



6-PIN DIP ZERO-CROSS OPTOISOLATORS TRIAC DRIVER OUTPUT (250/400 VOLT PEAK)

MOC3031M

MOC3032M

MOC3033M

MOC3041M

MOC3042M

MOC3043M

1. The mercury wetted relay provides a high speed repeated pulse to the D.U.T.
2. 100x scope probes are used, to allow high speeds and voltages.
3. The worst-case condition for static dv/dt is established by triggering the D.U.T. with a normal LED input current, then removing the current. The variable R_{TEST} allows the dv/dt to be gradually increased until the D.U.T. continues to trigger in response to the applied voltage pulse, even after the LED current has been removed. The dv/dt is then decreased until the D.U.T. stops triggering. τ_{RC} is measured at this point and recorded.

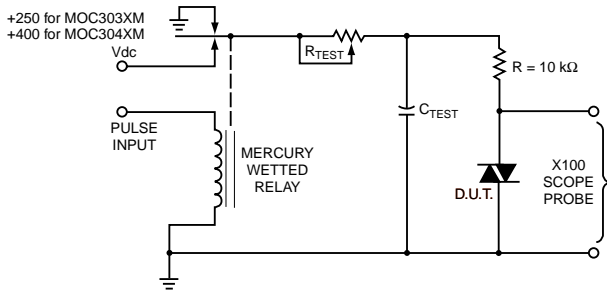

Figure 9. Static dv/dt Test Circuit

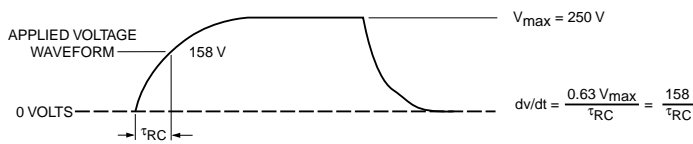

Figure 10. Static dv/dt Test Waveform (MOC3031M, MOC3032M, MOC3033M)

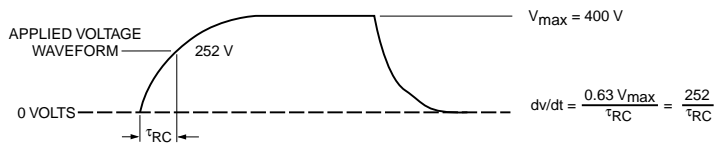
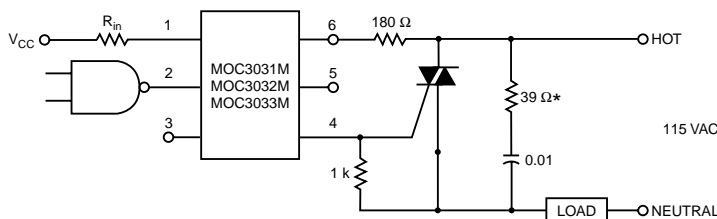

Figure 11. Static dv/dt Test Waveform (MOC3041M, MOC3042M, MOC3043M)

Typical circuit (Fig 12, 13) for use when hot line switching is required. In this circuit the “hot” side of the line is switched and the load connected to the cold or neutral side. The load may be connected to either the neutral or hot line.

R_{in} is calculated so that I_F is equal to the rated I_{FT} of the part, 5 mA for the MOC3033M and MOC3043M, 10 mA for the MOC3032M and MOC3042M, or 15 mA for the MOC3031M and MOC3041M. The 39 ohm resistor and 0.01 μ F capacitor are for snubbing of the triac and may or may not be necessary depending upon the particular triac and load used.



*For highly inductive loads (power factor < 0.5), change this value to 360 ohms.

Figure 12. Hot-Line Switching Application Circuit (MOC3031M, MOC3032M, MOC3033M)

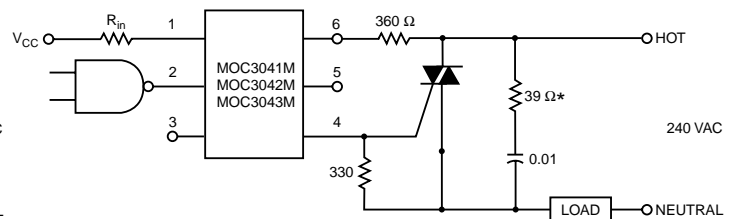

*For highly inductive loads (power factor < 0.5), change this value to 360 ohms.

Figure 13. Hot-Line Switching Application Circuit (MOC3041M, MOC3042M, MOC3043M)

6-PIN DIP ZERO-CROSS OPTOISOLATORS TRIAC DRIVER OUTPUT (250/400 VOLT PEAK)

MOC3031M

MOC3032M

MOC3033M

MOC3041M

MOC3042M

MOC3043M

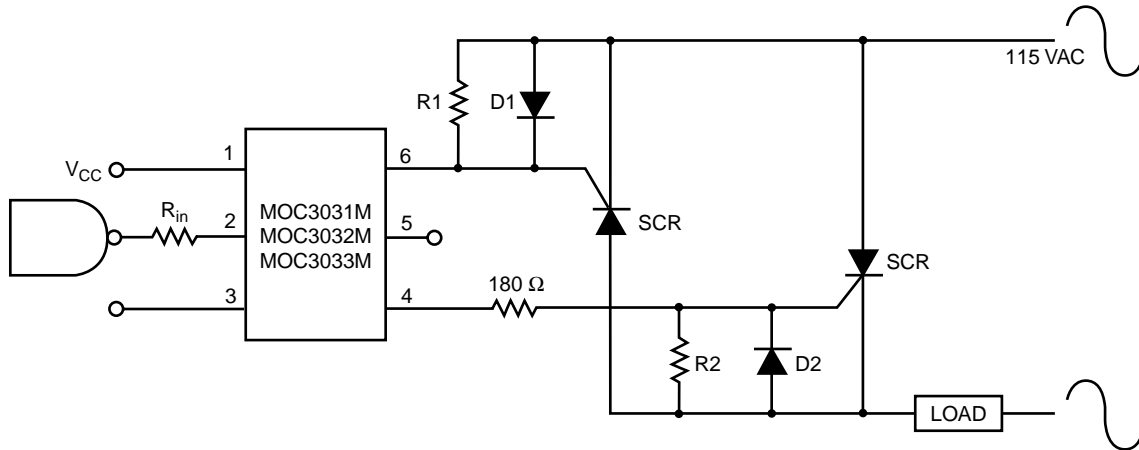

**Figure 14. Inverse-Parallel SCR Driver Circuit
(MOC3031M, MOC3032M, MOC3033M)**

Suggested method of firing two, back-to-back SCR's with a Fairchild triac driver. Diodes can be 1N4001; resistors, R_1 and R_2 , are optional 1 k ohm.

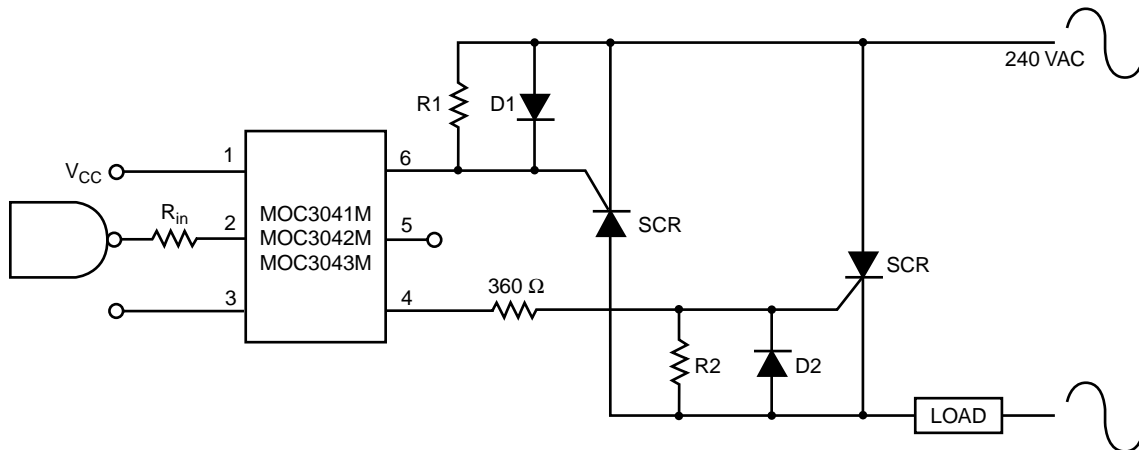

**Figure 15. Inverse-Parallel SCR Driver Circuit
(MOC3041M, MOC3042M, MOC3043M)**

Suggested method of firing two, back-to-back SCR's with a Fairchild triac driver. Diodes can be 1N4001; resistors, R_1 and R_2 , are optional 330 ohm.

Note: This optoisolator should not be used to drive a load directly. It is intended to be a trigger device only.

6-PIN DIP ZERO-CROSS OPTOISOLATORS TRIAC DRIVER OUTPUT (250/400 VOLT PEAK)

MOC3031M

MOC3032M

MOC3033M

MOC3041M

MOC3042M

MOC3043M

Package Dimensions (Through Hole)

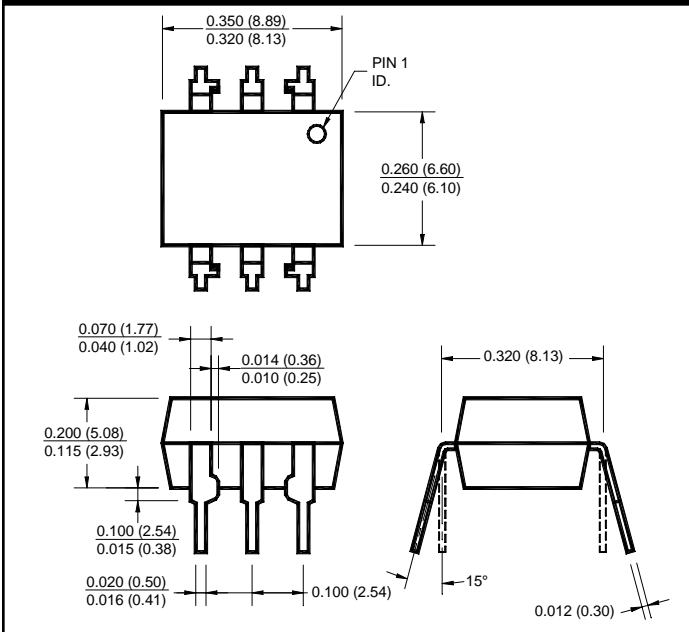

Package Dimensions (Surface Mount)

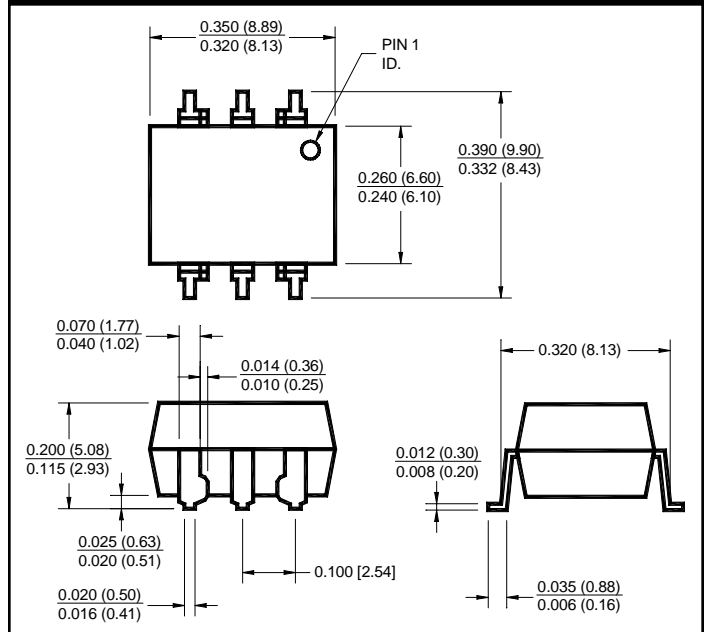

Package Dimensions (0.4" Lead Spacing)

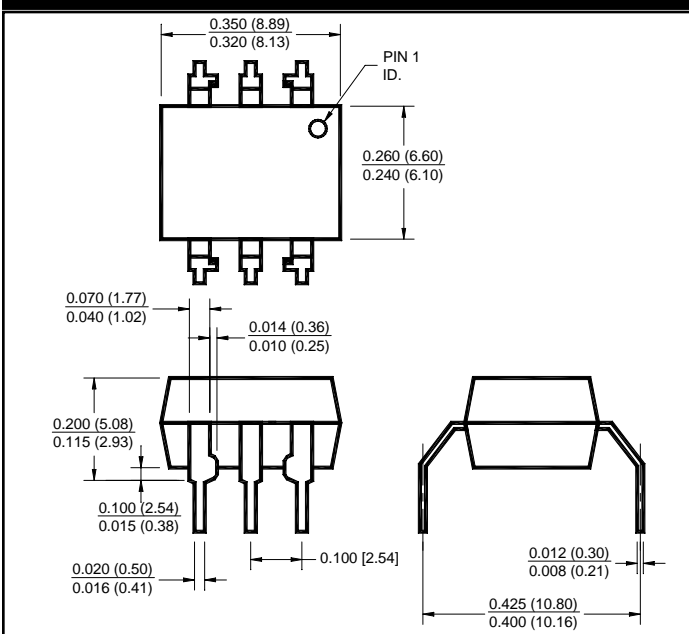

Recommended Pad Layout for Surface Mount Leadform

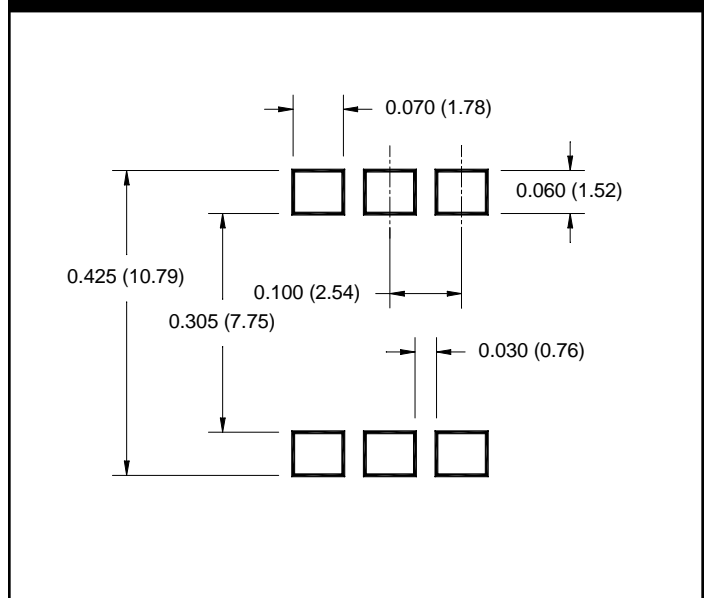

NOTE

All dimensions are in inches (millimeters)

6-PIN DIP ZERO-CROSS OPTOISOLATORS TRIAC DRIVER OUTPUT (250/400 VOLT PEAK)

MOC3031M

MOC3032M

MOC3033M

MOC3041M

MOC3042M

MOC3043M

ORDERING INFORMATION

Option	Order Entry Identifier	Description
S	S	Surface Mount Lead Bend
SR2	SR2	Surface Mount; Tape and reel
T	T	0.4" Lead Spacing
V	V	VDE 0884
TV	TV	VDE 0884, 0.4" Lead Spacing
SV	SV	VDE 0884, Surface Mount
SR2V	SR2V	VDE 0884, Surface Mount, Tape & Reel

Carrier Tape Specifications ("D" Taping Orientation)

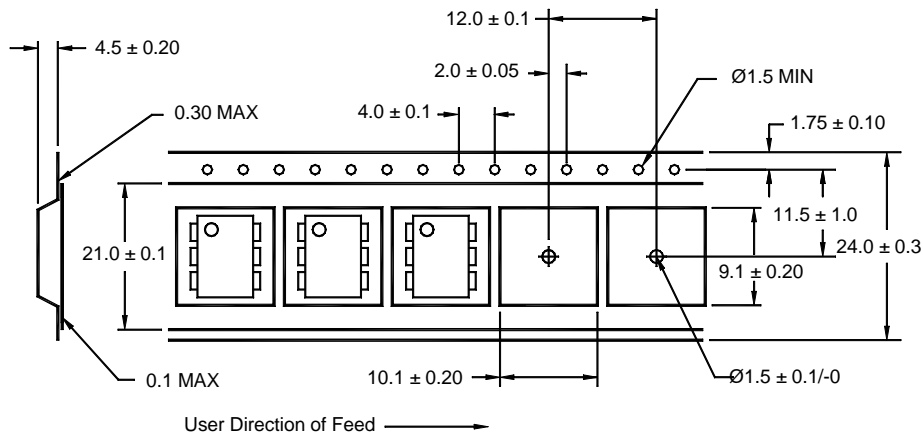

NOTE

All dimensions are in inches (millimeters)

6-PIN DIP ZERO-CROSS OPTOISOLATORS TRIAC DRIVER OUTPUT (250/400 VOLT PEAK)

MOC3031M

MOC3032M

MOC3033M

MOC3041M

MOC3042M

MOC3043M

DISCLAIMER

FAIRCHILD SEMICONDUCTOR RESERVES THE THE RIGHT TO MAKE CHANGES WITHOUT FURTHER NOTICE TO ANY PRODUCTS HEREIN TO IMPROVE RELIABILITY, FUNCTION OR DESIGN. FAIRCHILD DOES NOT ASSUME ANY LIABILITY ARISING OUT OF THE APPLICATION OR USE OF ANY PRODUCT OR CIRCUIT DESCRIBED HEREIN; NEITHER DOES IT CONVEY ANY LICENSE UNDER ITS PATENT RIGHTS, NOR THE RIGHTS OF OTHERS.

LIFE SUPPORT POLICY

FAIRCHILD'S PRODUCTS ARE NOT AUTHORIZED FOR USE AS CRITICAL COMPONENTS IN LIFE SUPPORT DEVICES OR SYSTEMS WITHOUT THE EXPRESS WRITTEN APPROVAL OF THE PRESIDENT OF FAIRCHILD SEMICONDUCTOR CORPORATION. As used herein:

1. Life support devices or systems are devices or systems which, (a) are intended for surgical implant into the body, or (b) support or sustain life, and (c) whose failure to perform when properly used in accordance with instructions for use provided in labeling, can be reasonably expected to result in a significant injury of the user.
 2. A critical component in any component of a life support device or system whose failure to perform can be reasonably expected to cause the failure of the life support device or system, or to affect its safety or effectiveness.
-