

JC400

MULTI AXIS JOYSTICK ANALOGUE OUTPUT

Developed for use in applications where compact size and functionality are important, the JC400 with analogue output offers proportional fingertip control in up to three axes. The JC400's range of ergonomic handles feature rotary operated potentiometers, or switches, for a third axis of control, or 'Person Present' switches that can be used to improve the integrity of your control system.

Installation flexibility has been provided by using different forms of mounting flanges independent of the function of the joystick and the analogue track models are supplied with side exit cables to minimize the required under panel depth. The joystick has been designed for maintenance-free operation throughout an operating life of greater than five million operations.

Typical applications include remote control chest packs, CCTV camera controls and the operator controls in construction, agricultural or material handling equipment.

PERFORMANCE MECHANICAL

Lever operating force

breakout	N	2, 2.5 or 3*
operating	N	7.5, 11 or 12* (full deflection)
maximum allowable	N	250* (full deflection)

Lever mechanical angle ° ±20 in X and Y directions

Lever action (options) Self centering, aligned X and Y or non aligned

Lever gate profiles (options) Single axis, square, round, diamond or cross

Expected life >5 million operations

Weight g 150 nominal, without handle fitted
*50mm above mounting flange face

ENVIRONMENTAL

Operating temperature °C -40 to +70

Storage temperature °C -50 to +85

Environmental protection above flange IP65 IEC 60529

ELECTRICAL

Analogue Track

Resolution Virtually infinite

Track resistance ±20% kΩ 4, 5 or 8

Track operating angle ° ±16

Output voltage range % 0-100, 10-90 or 25-75 of input (±2%)

Center tap voltage (no load) % 48 - 52 of applied voltage

Center tap angle ° ±2.5

Supply voltage - maximum Vdc 30

Wiper circuit impedance MΩ Greater than 0.1**

Power dissipation @ 20°C W 0.25 (no load)

** The long life resistive elements require a high impedance load in the wiper circuit to minimise the current flowing through the wiper for optimum conditions

Switch -

Directional or Center Off/Center On†

Switch operating angle ° 5 either side of center (±1)

Supply voltage - maximum Vdc 30

Load current - maximum mA 5 resistive (or 200 with reduced switch life of 1 million operations)

† The JC400 has an additional center on switch in each axis

DIMENSIONS

Note: drawings not to scale

INSTALLATION

The joystick is designed to be fitted from below the mounting panel, through a 37mm x 37mm square hole. The effectiveness of the joystick flange sealing is dependent on the panel mounting surface being sufficiently rigid to compress the sealing gaiter. The surface finish of the mounting panel is also critical to achieving an adequate seal and rough surface finishes, paint chips, deep scratches, etc. should be avoided.

Recommended panel thickness

3.5 to 6mm

Recommended screw torque

The JC400 joystick has three options for each mounting flange style, which include through holes and thread inserts in the 4mm diameter holes. To maintain an effective seal between the joystick flange and the mounting panel, the mounting screws should be tightened to a suitable torque to match the selected attachment screw size.

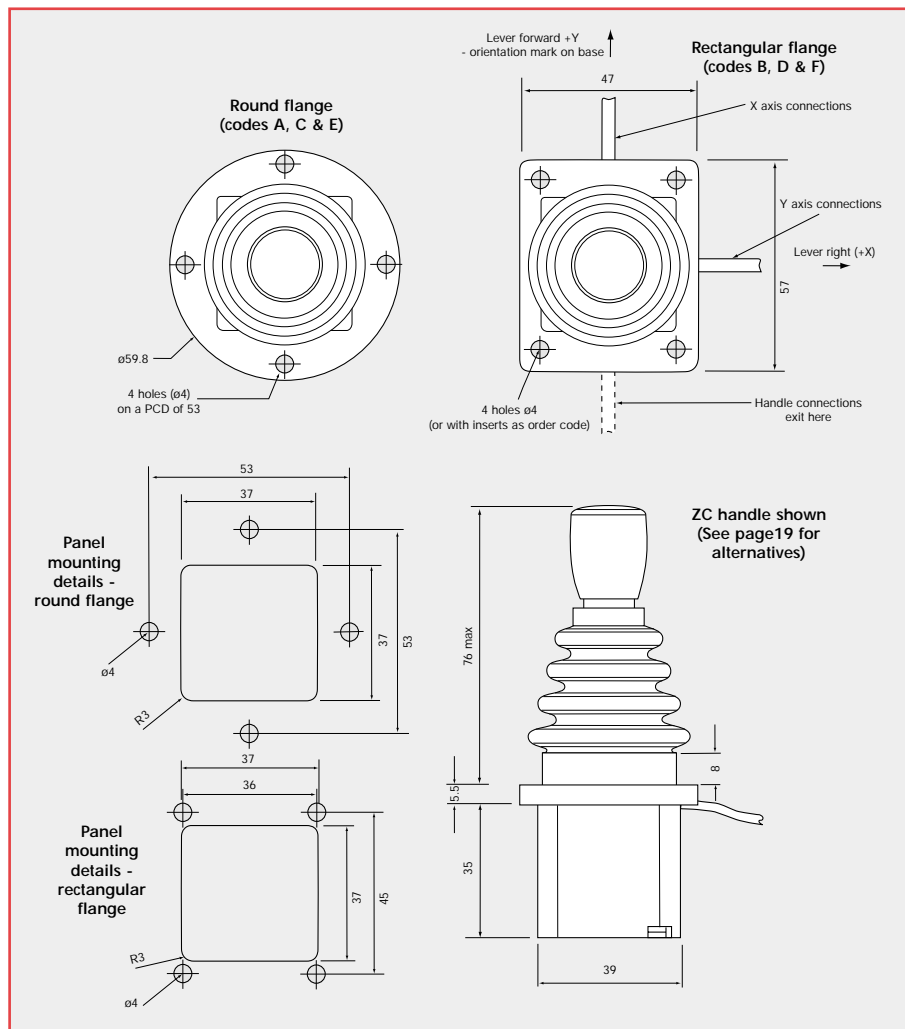

ELECTRICAL CONNECTIONS

PVC insulated 7/0.2 (24AWG) flying leads, 240mm long

Description

Y axis forward - positive voltage supply
 Y axis center tap
 Y axis backward - negative or zero voltage supply
 Y axis output voltage signal
 Y switch track N/O (lever forward +Y)
 Y switch track N/O (lever backward -Y)
 Y switch track center on
 Y switch track common

X axis right - positive voltage supply
 X axis center tap
 X axis left - negative or zero voltage supply
 X axis output voltage signal
 X switch track N/O (lever right +X)
 X switch track N/O (lever left -X)
 X switch track center on
 X switch track common

Flylead colour

Green
 Brown
 White
 Black
 Pink/Black
 Green/Red
 Red/Brown
 Yellow/Green

Orange
 Grey
 Red
 Yellow
 Orange/Black
 Red/Black
 Orange/Red
 Purple/Red

See over 
 for ordering information

JC400 ANALOGUE OUTPUT HOW TO SPECIFY

PERFORMANCE OPTIONS	FEATURE	CODE
MOUNTING FLANGE	Round flange, 59.8mm diameter with 4 x 4mm through holes	A
	Rectangular flange, 47 x 57mm with 4 x 4mm through holes	B
	Round, as code A, but with Metric thread inserts (M3 x 0.5p)	C
	Rectangular, as code B, but with Metric thread inserts (M3 x 0.5p)	D
	Round, as code A, but with Unified thread inserts (4-40 UNC x 0.025)	E
	Rectangular, as code B, but with Unified thread inserts (4-40 UNC x 0.025)	F
AXES	Single axis with analogue track	Y
	Dual axis	XY
TRACKS	Analogue potentiometer, 4k, 0-100%, $\pm 5^\circ$ directional switch	NN
	Analogue potentiometer, 5k, 10-90%, $\pm 5^\circ$ directional switch	RR
	Analogue potentiometer, 8k, 25-75%, $\pm 5^\circ$ directional switch	QQ
DETENTS	Not available with analogue tracks	-/-
LEVER SPRING FORCE	Light duty, 2N breakout, 7.5N full deflection	LA
	Medium duty, 2.5N breakout, 11N full deflection	MA
	Heavy duty, 3N breakout, 12N full deflection	HA
HANDLE STYLES See page 18	Standard handle, no functions	ZC
	Standard handle with momentary push button	ZC1
	Standard handle with momentary switch action	ZCS
	Rotary Z axis handle with analogue track and directional switch	ZA or ZA2
	Rotary Z axis handle with end of travel switches only	ZAS
	Finger grip handle with momentary top button switch	SW1
	Finger grip handle with two momentary side button switches	SW2
Finger grip handle with two momentary side and top button switches	SW3	
GATE (lever movement limiter)	Square	S
	Round	R
	Diamond	D
	Cross - only suitable for use with non-switched handles (ZC)	C
SEAT	Aligned with axis	P
	Non-aligned	N

EXAMPLE ORDER CODE **JC400-A-XY-NN-/-MA-ZA-S-P**

JC400

MULTI AXIS JOYSTICK DIGITAL OUTPUT

Developed for use in applications where compact size and functionality are important, the JC400 with Digital Output option offers fingertip control in one or two axes, with a choice of handles for a third axis of control. The JC400's range of ergonomic handles feature rotary operated potentiometers, or switches, or 'Person Present' switches that can be used to improve the integrity of your control system.

The Digital track option includes a detent mechanism that provides three sequential positions either side of the center position. The detent positions align with the switch outputs in true X and Y directions only.

Installation flexibility has been provided by using different forms of mounting flanges independent of the function of the joystick, and the digital output joysticks are fitted with standard electronic connectors to minimize installation time. The joystick has been designed for maintenance-free operation throughout an operating life of greater than five million operations.

Typical applications include remote control chest packs, CCTV camera controls and the operator controls in construction, agricultural or material handling equipment.

PERFORMANCE MECHANICAL

Lever operating force

breakout	N	3, 4 or 6*
operating	N	12, 13.5 or 18* (full deflection)
maximum allowable	N	250* (full deflection)

Lever mechanical angle

° ±20 in X and Y directions

Lever action (options)

Self centering, aligned X and Y or non aligned

Lever gate profiles (options)

Single axis, square, round, diamond or cross.

Expected life

>5 million operations

Weight

g 150 nominal, without handle fitted
*50mm above mounting flange face

ENVIRONMENTAL

Operating temperature

°C -40 to +70

Storage temperature

°C -50 to +85

Environmental protection above flange

IP65 IEC 60529

ELECTRICAL

Number of switch positions

3 either side of center

Number of detents

3 either side of center

Switch/detent angles

° ±6.6, ±13.3, ±20

Supply voltage - maximum

Vdc 30

Load current - maximum

mA 100 resistive @25°C

TRUTH TABLE

Truth table for digital switch track output Y and X axis signals are Normally Open (0) at lever center position. Switch sequences close (1) depending on direction of lever movement and detent position.

Detent Position	Switch Output			Right (or Forward)	Left (or Backward)
	1	2	3		
3	1	1	1	1	0
2	1	1	0	1	0
1	1	0	0	1	0
0	0	0	0	0	0
-1	1	0	0	0	1
-2	1	1	0	0	1
-3	1	1	1	0	1

DIMENSIONS

Note: drawings not to scale

INSTALLATION

The joystick is designed to be fitted from below the mounting panel, through a 37mm x 37mm square hole. The effectiveness of the joystick flange sealing is dependent on the panel mounting surface being sufficiently rigid to compress the sealing gaiter. The surface finish of the mounting panel is also critical to achieving an adequate seal and rough surface finishes, paint chips, deep scratches, etc. should be avoided.

Recommended panel thickness

3.5 to 6mm

Recommended screw torque

The JC400 joystick has three options for each mounting flange style, which include through holes and thread inserts in the 4mm diameter holes. To maintain an effective seal between the joystick flange and the mounting panel, the mounting screws should be tightened to a suitable torque to match the selected attachment screw size.

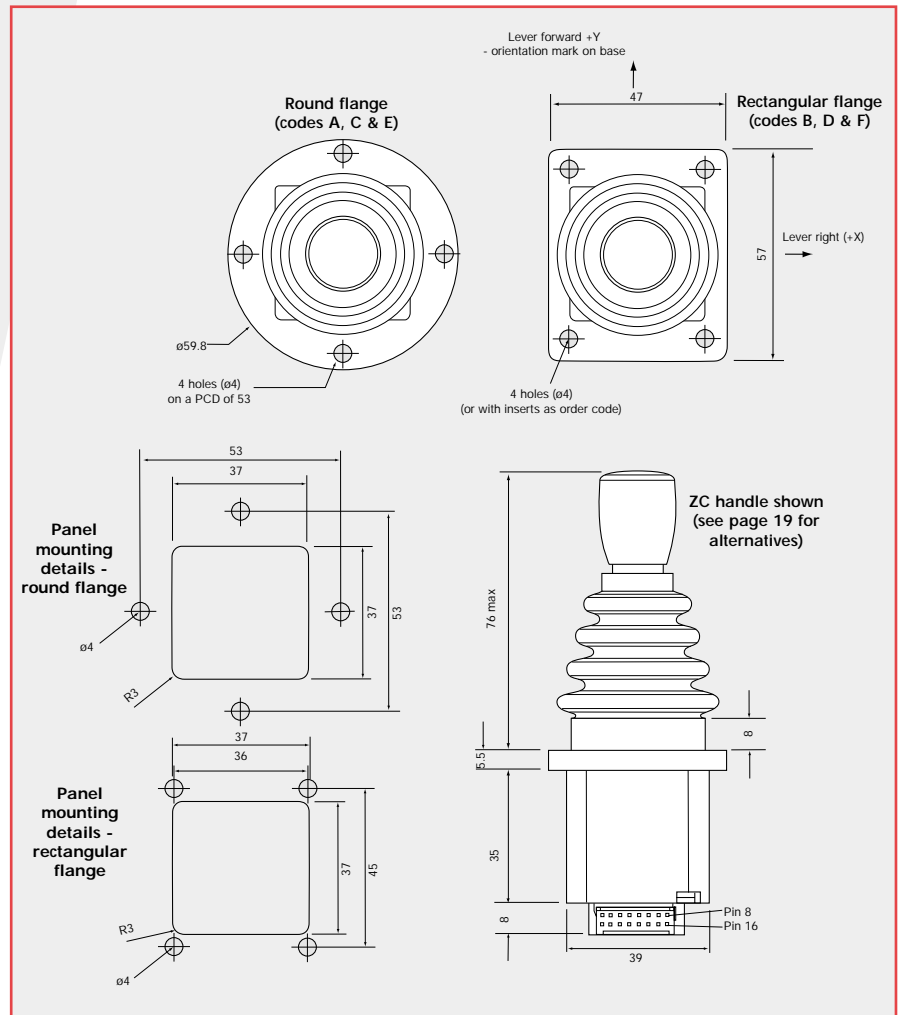

ELECTRICAL CONNECTIONS

Connection

Mating connector and pins kit
(order separately)

FCI DUBOX™ 2 x 8 way male connector (76385-308)

SA47363 (contains DUBOX™ 65239-008, 65239-002 and 65239-003 female connectors and pins 76357-301 suitable for AWG 22-30 wire size)

Requires crimping pliers (FCI No. HT234) to fit pins to wires.

Description	Connector Pin Number
Y axis switch 1	3
Y axis switch 2	14
Y axis switch 3	16
Y axis signal N/O (lever forward +Y)	9
Y axis signal N/O (lever backward -Y)	1
Y axis switch track common	5
X axis switch 1	4
X axis switch 2	7
X axis switch 3	10
X axis signal N/O (lever right +X)	2
X axis signal N/O (lever left -X)	6
X axis switch track common	5

JC400 DIGITAL OUTPUT HOW TO SPECIFY

PERFORMANCE OPTIONS

MOUNTING FLANGE

AXES

TRACKS

DETENTS

LEVER SPRING FORCE

HANDLE STYLES

See page 18

GATE

(lever movement limiter)

SEAT

FEATURES

Round flange, 59.8mm diameter with 4 x 4mm through holes
 Rectangular flange, 47 x 57mm with 4 x 4mm through holes
 Round, as code A, but with Metric thread inserts (M3 x 0.5p)
 Rectangular, as code B, but with Metric thread inserts (M3 x 0.5p)
 Round, as code A, but with Unified thread inserts (4-40 UNC x 0.025)
 Rectangular, as code B, but with Unified thread inserts (4-40 UNC x 0.025)

Single axis with digital track
 Dual axis

Digital - 3 switches either side of center

Only available with digital tracks

Light duty, 3N breakout, 12N full deflection
 Medium duty, 4N breakout, 13.5N full deflection
 Heavy duty, 6N breakout, 18N full deflection

Standard handle, no functions
 Standard handle with momentary switch action
 Rotary Z axis handle with analogue track and directional switch
 Rotary Z axis handle with end of travel switches only

Square
 Round
 Diamond
 Cross - only suitable for use with non-switched handles (ZC)

Aligned with axis
 Non-aligned

CODE

A
B
C
D
E
F

X
XY

DD

D

LD
MD
HD

ZC
ZCS
ZA or ZA2
ZAS

S
R
D
C

P
N

EXAMPLE ORDER CODE

JC400-B-XY-DD-D-MD-ZC-R-N

JC400 MULTI AXIS JOYSTICK HANDLE OPTIONS



ZA

The ZA and ZAS handles are designed to give an additional axis of proportional or switched control, using fingertip action to rotate the handle. The handles have a self-centering action when released, and rotate about their center, giving either analogue output with switched reference signals (ZA or ZA2) or end of travel switching only (ZAS).

ZC

The convex top profile of the ZC handle allows for simple thumb control of the JC400 range. 'Person present' switch functions can be incorporated by using the ZC1 external button switch or the ZCS internal switch to verify the change in signals from the joystick, which may help to increase the integrity of your control system.



SW

The cylindrical profile of the SW handle allows full grip use when controlling the JC400 range. 'Person present' switch functions can be incorporated by using a choice of three switch arrays which can offer a combination of finger and thumb activation. The external button switches can be used to verify the change in signals from the joystick, which may help to increase the integrity of your control system, or enable control of additional functions.

ZA HANDLE OPTION

PERFORMANCE

		ZA, ZA2	ZAS
Max height above flange	mm	80	80
Maximum diameter	mm	39	39
Operating temperature	°C	-25 to +50	-25 to +50
Environmental sealing (IEC 60529)		IP65	IP65

Z AXIS MECHANICAL

Handle rotational torque		
breakout	Nm	0.1
operating	Nm	0.15 to 0.25
maximum allowable	Nm	1
Handle mechanical angle	°	±29 to ±30
Handle action		Self centering
Expected life		1 million operations

Z AXIS ELECTRICAL

Analogue track (ZA and ZA2 only)

Resolution		Virtually infinite		
Track resistance ±20%	kΩ	3.1 or 5.4 (ZA2)	Center tap angle	° ±2.5
Track operating angle	°	±27	Supply voltage - maximum	Vdc 30
Output voltage range	%	7-93 or 25-75 (ZA2) of input	Wiper circuit impedance	MΩ > 0.1**
Center tap voltage (no load)	%	47 - 53 of applied voltage	Power dissipation @ 20°C	W 0.25(no load)

** The long life resistive elements require a high impedance load in the wiper circuit to minimise the current flowing through the wiper for optimum conditions

Z AXIS ELECTRICAL

Directional or Centre Switch

		ZA, ZA2	ZAS
Switch operating angle	°	4 either side of center (±1)	20 either side of center (±2)
Supply voltage - maximum	Vdc	30	30
Load current - maximum	mA	2 (resistive)	2 (resistive)

DIMENSIONS

Note: drawings not to scale

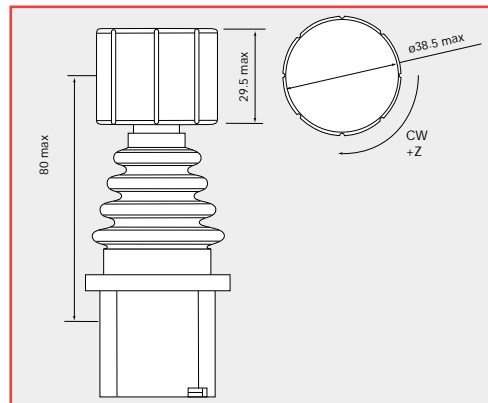

Installation note

The protective rubber cap must be removed before fitting the joystick through the mounting hole. Re-fit the rubber cap after mounting in the panel.

ELECTRICAL CONNECTIONS

Leads exit from the underside of the mounting flange. PVC insulated 7/0.2 (24AWG) flying leads, 240mm long

Description	Flylead colour	ZAS
Z axis positive voltage supply	Yellow/Red	-
Z axis center tap	Blue	-
Z axis negative or zero voltage supply	Violet	-
Z axis output voltage signal	Pink	-
Z switch track N/O (handle CW +Z)	Yellow/Black	Yellow/Black
Z switch track N/O (handle CCW -Z)	White/Red	White/Red
Z switch track common	Red/Blue	Red/Blue

ZC HANDLE OPTION

PERFORMANCE

	ZC	ZC1	ZCS
Max height above flange	mm 76	76	76
Maximum diameter	mm 23	23	23
Environmental sealing (IEC 60529)	IP65	IP65	IP65
Number of switches	0	1	1
Action	-	Momentary button	Momentary handle depress
Switch operating force	N -	3	7
Maximum current	mA -	200 @ 50Vdc	100 @ 30Vdc
Expected life (operations)	-	1 million	500,000

DIMENSIONS

Note: drawings not to scale

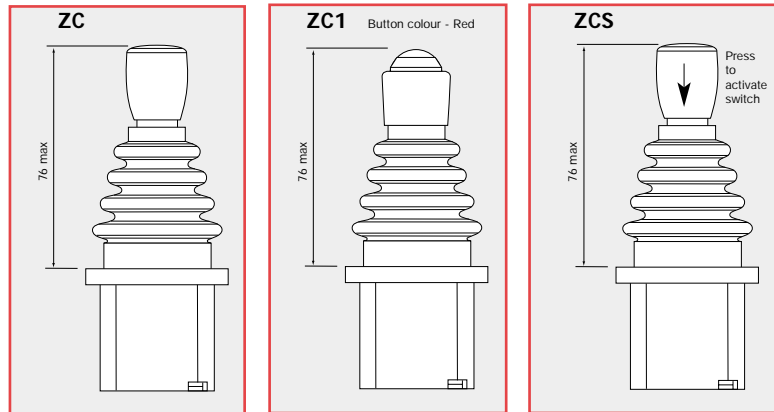

ELECTRICAL CONNECTIONS

Leads exit from the underside of the mounting flange. PVC insulated 7/0.2 (24AWG) flying leads, 240mm long

Description

Common terminal
N/O contact switch 1

ZC1/ZCS Flylead colour

Red/Green
White/Black

SW HANDLE OPTION

PERFORMANCE

	SW1	SW2	SW3
Max height above flange	mm 120	112	120
Maximum diameter	mm 28	28	28
Environmental sealing (IEC 60529)	IP65	IP65	IP65
Number of switches	1	2	3
Action	Momentary button		
Switch operating force	N 3		
Maximum current @ 50Vdc	mA 200		
Expected life (operations)	1 million		

DIMENSIONS

Note: drawings not to scale

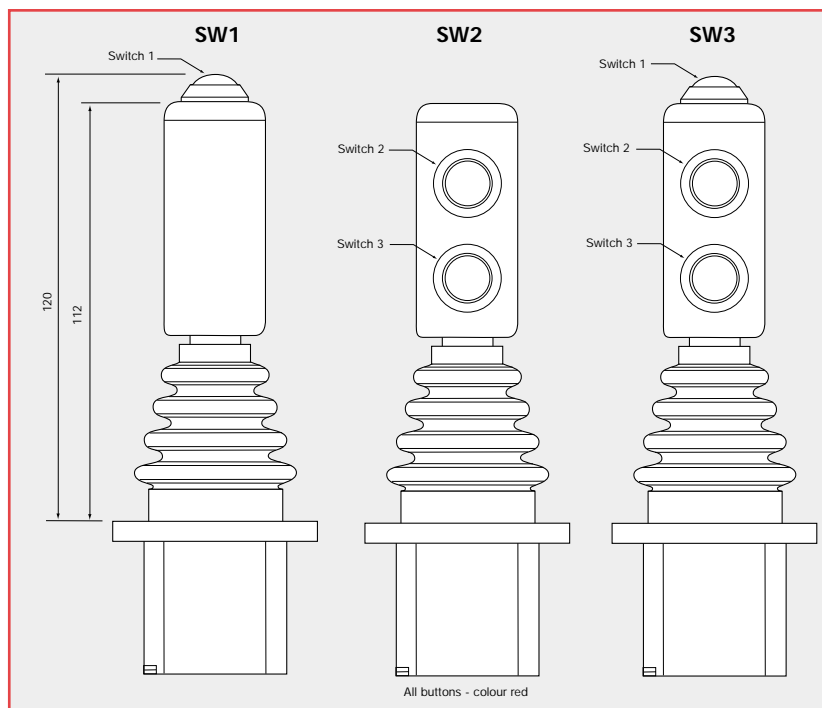

ELECTRICAL CONNECTIONS

Leads exit from the underside of the mounting flange. PVC insulated 7/0.2 (24AWG) flying leads, 240mm long

Description	Flylead colour		
	SW1	SW2	SW3
Common terminal	Black	Black	Black
N/O contact switch 1	White	-	White
N/O contact switch 2	-	Pink	Pink
N/O contact switch 3	-	Yellow	Yellow

This handle option is not available with JC400 Digital Output