

Technical Information



Imprint

As at:

13th edition, 2019

Copyright

by Dr. Fritz Faulhaber GmbH & Co. KG
Daimlerstr. 23 / 25 · 71101 Schönaich

All rights reserved, including translation rights. No part of this description may be duplicated, reproduced, stored in an information system or processed or transferred in any other form without prior express written permission of Dr. Fritz Faulhaber GmbH & Co. KG.

This document has been prepared with care. Dr. Fritz Faulhaber GmbH & Co. KG cannot accept any liability for any errors in this document or for the consequences of such errors. Equally, no liability can be accepted for direct or consequential damages resulting from improper use of the products.

Subject to modifications.

The respective current version of this document is available on FAULHABER's website: www.faulhaber.com

Contents

DC-Motors	DC-Micromotors Flat DC-Micromotors & DC-Gearmotors	4 – 25
Brushless DC-Motors	Brushless DC-Servomotors Brushless Flat DC-Micromotors & DC-Gearmotors	26 – 51
Motors with integrated Electronics	Brushless DC-Motors with integrated Speed Controller Brushless DC-Servomotors with integrated Motion Controller	52 – 87
Stepper Motors	Stepper Motors	88 – 97
Linear DC-Servomotors	Linear DC-Servomotors	98 – 105
Precision Gearheads	Precision Gearheads	106 – 119
Linear Components	Ball Screws Lead Screws and Options	120 – 127
Encoders	Encoders – 2 Channel Encoders – 3 Channel Encoder – Absolute	128 – 140
Drive Electronics	Speed Controller Motion Controller	141 – 161

DC-Motors

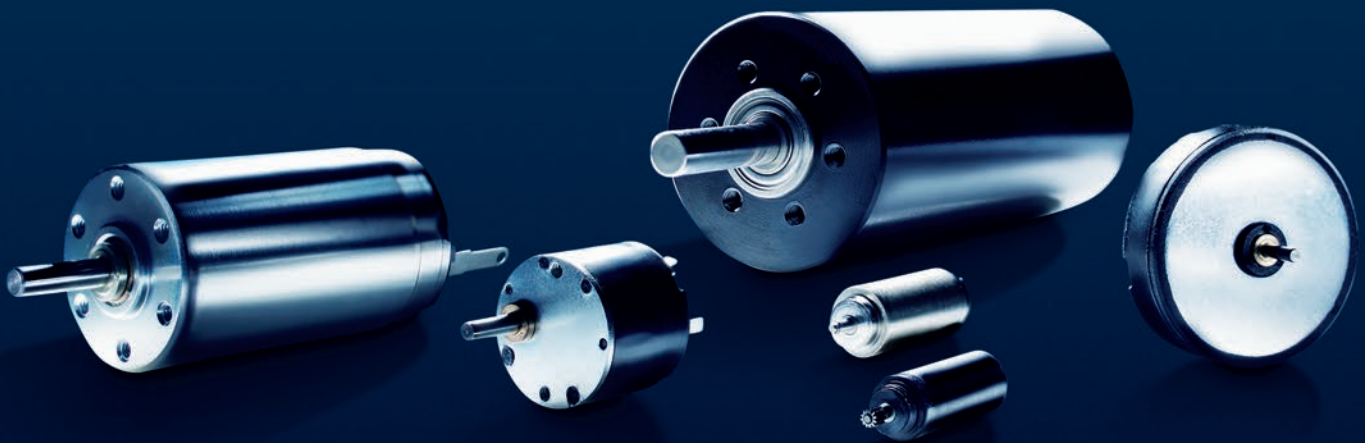

DC-Micromotors

Technical Information

General information

The FAULHABER Winding:

Originally invented by Dr. Fritz Faulhaber Sr. and patented in 1958, the System FAULHABER coreless (or ironless) progressive, self-supporting, skew-wound rotor winding is at the heart of every System FAULHABER DC Motor. This revolutionary technology changed the industry and created new possibilities for customer application of DC Motors where the highest power, best dynamic performance, in the smallest possible size and weight are required. The main benefits of this technology include:

- No cogging torque resulting in smooth positioning and speed control and higher overall efficiency than other DC motor types
- Extremely high torque and power in relation to motor size and weight
- Absolute linear relationship between load to speed, current to torque, and voltage to speed
- Very low rotor inertia which results in superior dynamic characteristics for starting and stopping
- Extremely low torque ripple and EMI

DC Motor Types:

FAULHABER DC Motors are built with two different types of commutation systems: precious metal commutation and graphite commutation.

The term precious metal commutation refers to the materials used in the brushes and commutator which consist of high performance precious metal alloys. This type of commutation system is used mainly because of its very small size, very low contact resistance and the very precise commutation signal. This commutation system is particularly well suited for low current applications such as battery operated devices.

In general, precious metal commutated motors exhibit the best overall performance at continuous duty with a load at or around the point of maximum nominal efficiency.

The term graphite commutation refers to the brush material used in combination with a copper alloy commutator. This type of commutation system is very robust and is better suited to dynamic high power applications with rapid start / stops or periodic overload conditions.

Magnets:

FAULHABER DC Motors are designed with a variety of different types of magnets to suit the particular performance of the given motor type. These materials include AlNiCo magnets and high performance rare earth types such as SmCo and NdFeB.

Operational Lifetime:

The lifetime of a FAULHABER DC Motor depends mainly on the operational duty point and the ambient conditions during operation. The total hours of operation can therefore vary greatly from some hundreds of hours under extreme conditions to over 25 000 hours under optimal conditions. Under typical load conditions a FAULHABER DC motor will have an operational lifetime anywhere between 1 000 to 5 000 hours.

In general the operational lifetime of a FAULHABER DC Motor is limited by the effects of electrical and mechanical wear on the commutator and brushes. The electrical wear (sparking) depends heavily on the electrical load and the motor speed. As the electrical load and speed increase, the typical motor operational lifetime will normally decrease. The effects of electrical wear are more significant for motors with precious metal commutation and vary depending on the nominal voltage of the winding. Where necessary FAULHABER DC Motors are therefore fitted with integrated spark suppression to minimize the negative effects of sparking on the operational lifetime.

The mechanical wear of the commutation system is dependent on the motor speed and will increase with higher speeds. In general, for applications with higher than specified speeds and loads, a longer operational lifetime can be achieved by graphite commutated motors. It is also important not to exceed the load characteristics for the motor bearings given in the data sheet for continuous duty operation. Doing so will also limit the achievable motor lifetime.

Other effects limiting motor lifetime include ambient conditions like excessive humidity and temperature, excessive vibration and shock, and an incorrect or suboptimal mounting configuration of the motor in the application.

It is also important to note that the method of driving and controlling the motor will have a large effect on the operational lifetime of the motor. For example, for control using a PWM signal, FAULHABER recommends a minimum frequency of 20 kHz.

DC-Micromotors

Technical Information

Modifications:

FAULHABER specializes in the configuration of its standard products to fit the customer application. Available modifications for FAULHABER DC Motors include:

- Many other nominal voltage types
- Motor leads (PTFE and PVC) and connectors
- Configurable shaft lengths and second shaft ends
- Modified shaft dimensions and pinion configurations such as flats, gears, pulley and eccenters
- Modifications for extreme high and low temperature operation
- Modifications for operation in a vacuum (ex. 10^{-5} Pa)
- Modifications for high speed and / or high load applications
- Modifications for motors with tighter than standard electrical or mechanical tolerances

Product Combinations

FAULHABER offers the industry's largest selection of complementary products tailor made for all of its DC Motors including:

- Precision Gearheads (planetary, spur, and low backlash spur)
- High resolution Encoders (Incremental and Absolute)
- High Performance Drive Electronics (Speed Controllers, Motion Controllers)

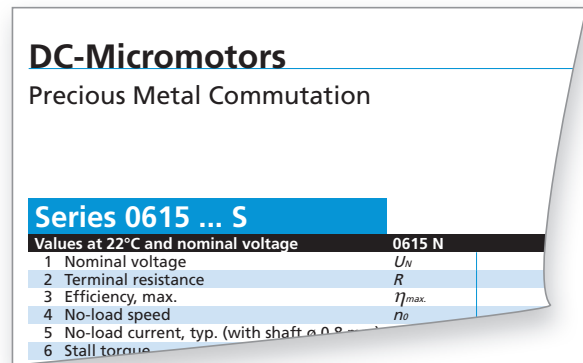

Values at 22°C and nominal voltage		0615 N
1	Nominal voltage	U_N
2	Terminal resistance	R
3	Efficiency, max.	η_{max}
4	No-load speed	n_o
5	No-load current, typ. (with shaft at 0.8 mm/s)	
6	Stall torque	

Notes on technical datasheet

The following values are measured or calculated at nominal voltage with an ambient temperature of 22 °C.

Nominal voltage U_N [V]

The nominal voltage at which all other characteristics indicated are measured and rated.

Terminal resistance R [Ω] $\pm 12\%$

The resistance measured across the motor terminals.

The value will vary according to the winding temperature. (temperature coefficient: $\alpha_{22} = 0,004 \text{ K}^{-1}$).

This type of measurement is not possible for the graphite commutated motors due to the transition resistance of the brushes.

Efficiency η_{max} [%]

The maximum ratio between the absorbed electrical power and the obtained mechanical power of the motor.

$$\eta_{max} = \left(1 - \sqrt{\frac{I_o \cdot R}{U_N}}\right)^2$$

No-load speed n_o [min^{-1}] $\pm 12\%$

Describes the motor speed under no-load conditions at steady state and 22 °C ambient temperature. If not otherwise defined the tolerance for the no-load speed is assumed to be $\pm 12\%$.

$$n_o = \frac{U_N - (I_o \cdot R)}{2\pi \cdot K_M}$$

No-load current (typical) I_o [A]

Describes the typical current consumption of the motor without load at an ambient temperature of 22 °C after reaching a steady state condition.

The no-load current is speed and temperature dependent. Changes in ambient temperature or cooling conditions will influence the value. In addition, modifications to the

shaft, bearing, lubrication, and commutation system or combinations with other components such as gearheads or encoders will all result in a change to the no-load current of the motor.

Stall torque M_H [mNm]

The torque developed by the motor at zero speed (locked rotor) and nominal voltage. This value may vary due to the magnet type and temperature and the temperature of the winding.

$$M_H = k_M \cdot \frac{U_N}{R} - M_R$$

Friction torque M_R [mNm]

Torque losses caused by the friction of brushes, commutator and bearings. This value varies due to temperature.

$$M_R = k_M \cdot I_o$$

Speed constant k_n [min⁻¹/V]

The speed variation per Volt applied to the motor terminals at constant load.

$$k_n = \frac{n_o}{U_N - I_o \cdot R} = \frac{1}{k_E}$$

Back-EMF constant k_E [mV/min⁻¹]

The constant corresponding to the relationship between the induced voltage in the rotor and the speed of rotation.

$$k_E = 2\pi \cdot k_M$$

Torque constant k_M [mNm/A]

The constant corresponding to the relationship between the torque developed by the motor and the current drawn.

Current constant k_I [A/mNm]

Describes the relation of the current in the motor winding and the torque developed at the output shaft.

$$k_I = \frac{1}{k_M}$$

Slope of n-M curve $\Delta n / \Delta M$ [min⁻¹/mNm]

The ratio of the speed variation to the torque variation. The smaller the value, the more powerful the motor.

$$\frac{\Delta n}{\Delta M} = \frac{R}{k_M^2} \cdot \frac{1}{2\pi}$$

Rotor inductance L [μH]

The inductance measured on the motor terminals at 1 kHz.

Mechanical time constant τ_m [ms]

The time required for the motor to reach a speed of 63% of its final no-load speed, from standstill.

$$\tau_m = \frac{R \cdot J}{k_M^2}$$

Rotor inertia J [gcm²]

The dynamic moment of inertia of the rotor.

Angular acceleration α_{max} [rad/s²]

The acceleration obtained from standstill under no-load-conditions and at nominal voltage.

$$\alpha_{max} = \frac{M_H}{J}$$

Thermal resistance R_{th1} ; R_{th2} [K/W]

R_{th1} corresponds to the thermal resistance between the winding and housing. R_{th2} corresponds to the thermal resistance between the housing and the ambient air. R_{th2} can be reduced by enabling exchange of heat between the motor and the ambient air (for example, a thermally coupled mounting configuration, using a heat sink, and / or forced air cooling).

Thermal time constant τ_{w1} ; τ_{w2} [s]

The thermal time constant specifies the time needed for the winding (τ_{w1}) and housing (τ_{w2}) to reach a temperature equal to 63% of final steady state value.

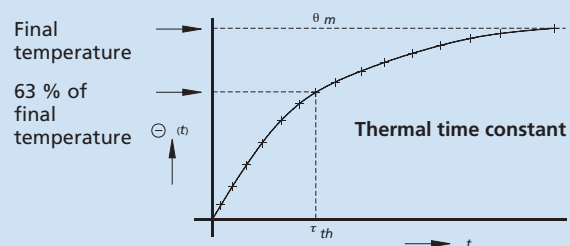

Operating temperature range [°C]

Indicates the minimum and maximum standard motor operating temperature, as well as the maximum allowable temperature of the standard motor winding.

Shaft bearings

The bearings used for the DC-Micromotors.

Shaft load max. [N]

The output shaft load at a specified shaft diameter for the primary output shaft. For motors with ball bearings the load and lifetime are in accordance with the values given by the bearing manufacturers. This value does not apply to second, or rear shaft ends.

Shaft play [mm]

The play between the shaft and bearings, including the additional bearing play in the case of ball bearings.

DC-Micromotors

Technical Information

Housing material

The housing material and the surface protection.

Mass [g]

The typical mass of the motor in its standard configuration.

Direction of rotation

The direction of rotation as viewed from the front face. Positive voltage applied to the (+) terminal gives clockwise rotation of the motor shaft. All motors are designed for clockwise (CW) and counter-clockwise (CCW) operation; the direction of rotation is reversible.

Speed up to n_{max} . [min⁻¹]

The maximum recommended motor speed for continuous operation. This value is based on the recommended operating range for the standard motor bearings, winding, and commutation system. All values in excess of this value will negatively affect the maximum achievable operational lifetime of the motor.

Number of pole pairs

Indicates the number of pole pairs of the standard motor.

Magnet material

Describes the basic type of the magnet used in the standard motor.

Unspecified mechanical tolerances:

Tolerances in accordance with ISO 2768.

≤ 6 = ± 0,1 mm

≤ 30 = ± 0,2 mm

≤ 120 = ± 0,3 mm

The tolerances of values not specified are given on request.

All mechanical dimensions related to the motor shaft are measured with an axial preload of the shaft toward the motor.

Rated values for continuous duty operation

The following values are measured or calculated at nominal voltage with an ambient temperature of 22 °C.

Rated Torque M_N [mNm]

For DC motors with precious metal commutation:

The maximum continuous duty torque at nominal voltage resulting in steady state current and speed not exceeding the capacity of the brush and commutation system. The motor is rated without a reduction to the R_{th2} value (without external cooling). This value can be safely exceeded if the motor is operated intermittently, for example, in S2 operation and/or if more cooling is applied. For the purposes of the rating, certain motors are limited by the resulting rated speed (< 2 500 min⁻¹) at nominal voltage.

Please note, when choosing a precious metal commutated motor that they exhibit the best overall continuous duty performance at or around the point of highest efficiency. For continuous duty operating conditions that require the motor to operate close to its thermal limits, a DC Motor with graphite commutation is recommended.

For DC Motors with graphite commutation:

The maximum continuous duty torque (S1 operation) at nominal voltage resulting in a steady state temperature not exceeding the maximum winding temperature and / or operating temperature range of the motor. The motor is rated with a reduction of the R_{th2} value of 25% which approximates the amount of cooling available from a typical mounting configuration of the motor. This value can be safely exceeded if the motor is operated intermittently, for example, in S2 operation and/or if more cooling is applied.

Rated Current (thermal limit) I_N [A]

The typical maximum continuous current at steady state resulting from the rated continuous duty torque. This value includes the effects of a loss of K_m (torque constant) as it relates to the temperature coefficient of the winding as well as the thermal characteristics of the given magnet material. This value can be safely exceeded if the motor is operated intermittently, during start / stop, in the ramp up phases of the operating cycle and/or if more cooling is applied. For certain series and lower voltage types this current is limited by the capacity of the brush and commutation system.

Rated Speed n_N [min⁻¹]

The typical speed at steady state resulting from the application of the given rated torque. This value includes the effects of motor heating on the slope of the n/M curve. Higher speeds can be achieved by increasing the input voltage to the motor, however the rated current (thermal limit) remains the same.

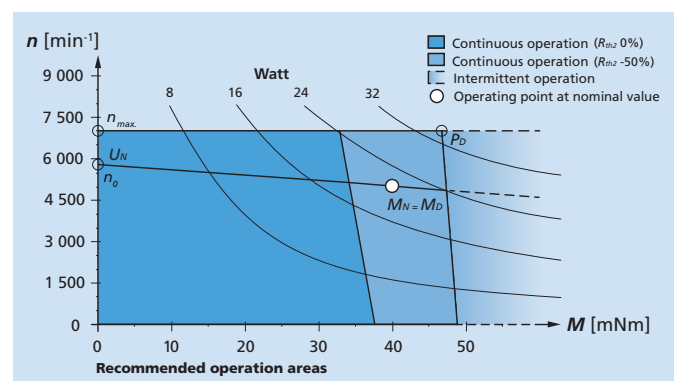

Example: Performance diagram for rated values with continuous operation (graphite commutation)

Explanations on the performance diagram

The performance diagram shows the range of possible operating points of a drive at an ambient temperature of 22 °C and includes both the operation in the thermally insulated and in the cooled state. The possible speed ranges are shown in dependence on the shaft torque.

The sector shown dashed describes possible operating points in which the drive can be engaged in intermittent operation or with increased cooling.

Continuous torque M_D [mNm]

Describes the max. recommended continuous torque in the steady-state condition at nominal voltage and with thermal reduction of the R_{th2} value by 25 % for graphite commutation and by 0 % for precious metal commutation. With brush motors, the continuous torque corresponds to the respective rated torque M_N . The value is independent of the continuous output and can be exceeded if the motor is intermittently operated and/or more cooling is put to use.

Continuous output P_D [W]

Describes the max. possible output in continuous operation in the steady-state condition with thermal reduction of the R_{th2} value by 50 %. The value is independent of the continuous torque and can be exceeded if the motor is intermittently operated and/or more cooling is put to use.

Nominal voltage characteristic curve U_N [V]

The nominal voltage curve describes the operating points at U_N in the uncooled and cooled state. In steady-state, the starting point corresponds to the no-load speed n_0 of the drive. Operating points above this curve can be attained by an increase, operating points below by a reduction of the nominal voltage .

How to select a DC-Micromotor

This section provides a very basic step-by-step procedure of how to select a DC-Micromotor for an application that requires continuous duty operation under constant load and ambient conditions. The example describes the calculations necessary to create a basic motor characteristic curve to describe the behaviour of the motor in the application. To simplify the calculation, in this example continuous operation and optimum life performance are assumed and the influence of temperature and tolerances has been omitted.

Application data:

The basic data required for any given application are:

Required torque	M
Required speed	n
Duty cycle	δ
Available supply voltage, max.	U
Available current, max.	I
Available space, max.	diameter/length
Shaft load	radial/axial
Ambient temperature	

This example is based on the following application data:

Output torque	M	= 3	mNm
Speed	n	= 5 500	min ⁻¹
Duty cycle	δ	= 100	%
Supply voltage	U	= 20	V
Current source, max.	I	= 0,5	A
Space max	diameter	= 25	mm
	length	= 50	mm
Shaft load	radial	= 1,0	N
	axial	= 0,2	N
Ambient temperature		= 22 °C	constant

Preselection

The first step is to calculate the power the motor is expected to deliver:

$$P_2 = M \cdot 2 \pi n$$

$$P_2 = 3 \text{ mNm} \cdot 5\,500 \text{ min}^{-1} \cdot 2\pi = 1,73 \text{ W}$$

Second, compare the physical dimensions (diameter and length) to the motor sizes given in the data sheets. Then, from the available motor sizes, compare the required output torque to the diagram for the recommended areas of operation for the motor types in question. Please choose a motor type where the required output torque and speed are well within the limits given in the diagram. For the best results it is recommended to operate the motor close to the "operating point at nominal value" indicated in the diagram. Please note that the diagram in the data sheet is a representative example regarding one nominal voltage type and should be used for orientation purposes only.

DC-Micromotors

Technical Information

The motor selected from the catalogue for this particular application, is **series 2224 U 024 SR** with the following characteristics:

Nominal voltage	U_N	= 24	V
Frame size:	\emptyset	= 22	mm
	L	= 24	mm
Shaft load, max.:	radial	= 1,5	N
	axial	= 0,2	N
No-load current	I_o	= 0,007	A
No-load speed	n_o	= 7 800	min ⁻¹
Stall torque	M_H	= 19	mNm

Optimizing the preselection

To optimize the motor's operation and life performance, the required speed n has to be higher than half the no-load speed n_o at nominal voltage, and the load torque M has to be less than half the stall torque M_H .

$$n \geq \frac{n_o}{2} \quad M \leq \frac{M_H}{2}$$

From the data sheet for the DC-Micromotor, **2224 U 024 SR** the parameters meet the above requirements.

$$n = 5\,500 \text{ min}^{-1} \text{ is higher than } \frac{7\,800 \text{ min}^{-1}}{2} = 3\,900 \text{ min}^{-1} = \frac{n_o}{2}$$

$$M = 3 \text{ mNm} \text{ is lower than } \frac{19 \text{ mNm}}{2} = 9,5 \text{ mNm} = \frac{M_H}{2}$$

This DC-Micromotor will be a good first choice to test in this application. Should the required speed n be less than half the no-load speed n_o , and the load torque M be less than half the stall torque M_H , the motor with the next higher nominal voltage U_N should be selected.

Should the required torque M be compliant but the required speed n be less than half the no-load speed n_o , try a lower supply voltage or another smaller frame size motor.

Should the required speed be well below half the no-load speed and or the load torque M be more than half the stall torque M_H , a gearhead or a larger frame size motor has to be selected.

Performance characteristics at nominal voltage (24 V)

A graphic presentation of the motor's characteristics can be obtained by calculating the stall current I_H and the torque $M_{opt.}$ at its point of max. efficiency. All other parameters are taken directly from the data sheet of the selected motor.

Stall current

$$I_H = \frac{U_N}{R}$$

$$I_H = \frac{24 \text{ V}}{36,3 \Omega} = 0,661 \text{ A}$$

Torque at max. efficiency

$$M_{opt.} = \sqrt{M_H \cdot M_R}$$

$$M_{opt.} = \sqrt{19 \text{ mNm} \cdot 0,2 \text{ mNm}} = 1,95 \text{ mNm}$$

It is now possible to make a graphic presentation and draw the motor diagram (see diagram 1).

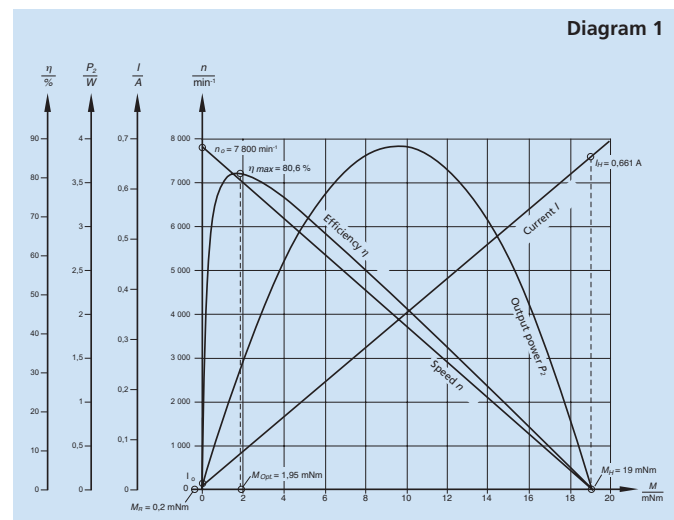

Calculation of the main parameters

In this application the available supply voltage is lower than the nominal voltage of the selected motor. The calculation under load therefore is made at 20 V.

No-load speed n_o at 20 V

$$n_o = \frac{U - (I_o \cdot R)}{2\pi \cdot k_M}$$

inserting the values

Supply voltage	U	=	20	V
Terminal resistance	R	=	36,3	Ω
No-load current	I_o	=	0,007	A
Torque constant	k_M	=	29,1	mNm / A

$$n_o = \frac{20 \text{ V} - (0,007 \text{ A} \cdot 36,3 \Omega)}{2\pi \cdot 29,1 \text{ mNm / A}} = 6\,481 \text{ min}^{-1}$$

Stall current I_H

$$I_H = \frac{U}{R}$$

$$I_H = \frac{20 \text{ V}}{36,3 \Omega} = 0,551 \text{ A}$$

Stall torque M_H

$$M_H = k_M \left(\frac{U}{R} - I_o \right)$$

$$M_H = 29,1 \text{ mNm / A} \cdot \left(\frac{20 \text{ V}}{36,3 \Omega} - 0,007 \text{ A} \right) = 15,83 \text{ mNm}$$

Efficiency, max. η_{max} .

$$\eta_{max} = \left(1 - \sqrt{I_o \cdot \frac{R}{U}} \right)^2$$

$$\eta_{max} = \left(1 - \sqrt{0,007 \text{ A} \cdot \frac{36,3 \Omega}{20 \text{ V}}} \right)^2 = 78,9 \%$$

At the point of max. efficiency, the torque delivered is:

$$M_{opt} = \sqrt{M_H \cdot M_R}$$

inserting the values

Friction torque	M_R	=	0,2	mNm
and				
Stall torque with 20 V	M_H	=	15,83	mNm

$$M_{opt} = \sqrt{15,83 \text{ mNm} \cdot 0,2 \text{ mNm}} = 1,78 \text{ mNm}$$

Calculation of the operating point at 20 V

When the torque ($M=3$ mNm) at the working point is taken into consideration I , n , P_2 and η can be calculated:

Current at the operating point

$$I_{Last} = \frac{M + M_R}{k_M}$$

$$I_{Last} = \frac{3 \text{ mNm} + 0,2 \text{ mNm}}{29,1 \text{ mNm / A}} = 0,11 \text{ A}$$

Speed at the operating point

$$n = \frac{U - R \cdot I_{Last}}{2\pi \cdot k_M}$$

$$n = \frac{20 \text{ V} - 36,3 \Omega \cdot 0,11 \text{ A}}{2\pi \cdot 29,1 \text{ mNm / A}} = 5\,253 \text{ min}^{-1}$$

Output power at the operating point

$$P_2 = M \cdot 2\pi \cdot n$$

$$P_2 = 3 \text{ mNm} \cdot 2\pi \cdot 5\,253 \text{ min}^{-1} = 1,65 \text{ W}$$

Efficiency at the operating point

$$\eta = \frac{P_2}{U \cdot I}$$

$$\eta = \frac{1,65 \text{ W}}{20 \text{ V} \cdot 0,11 \text{ A}} = 75,0 \%$$

In this example the calculated speed at the working point is different to the required speed, therefore the supply voltage has to be changed and the calculation repeated.

Supply voltage at the operating point

The exact supply voltage at the operating point can now be obtained with the following equation:

$$U = R \cdot I_{Load} + 2\pi \cdot n \cdot k_M$$

$$U = 36,3 \Omega \cdot 0,11 \text{ A} + 2\pi \cdot 5\,500 \text{ min}^{-1} \cdot 29,1 \text{ mNm / A} = 20,75 \text{ V}$$

In this calculated example, the parameters at the operating point are summarized as follows:

Supply voltage	U	=	20,75	V
Speed	n	=	5 500	min ⁻¹
Output torque	M_N	=	3	mNm
Current	I	=	0,11	A
Output power	P_2	=	1,73	W
Efficiency	η	=	75,7	%

DC-Micromotors

Technical Information

Estimating the temperature of the motor winding in operation:

To ensure that the motor operates within a permissible temperature range, it is necessary to calculate the temperature of the winding and housing under load. First calculate the approximate motor losses using the following formula:

$$P_{Loss} = I_{Load}^2 \cdot R$$

inserting the values

Current	$I_{Load} = 0,11 \text{ A}$
Resistance	$R = 36,3 \Omega$

$$P_{Loss} = (0,11 \text{ A})^2 \cdot 36,3 \Omega = 0,44 \text{ W}$$

Then multiply the value for the power losses by the combined thermal resistances of the motor to estimate the change in the temperature of the motor due to the load.

$$\Delta T = P_{Loss} \cdot (R_{th1} + R_{th2})$$

inserting the values

Thermal resistance 1	$R_{th1} = 5 \text{ K/W}$
Thermal resistance 2	$R_{th2} = 20 \text{ K/W}$

$$\Delta T = 0,44 \text{ W} \cdot (5 \text{ K/W} + 20 \text{ K/W}) = 11 \text{ K}$$

Add the resulting change in temperature ΔT to the ambient temperature to estimate the motor winding temperature under load.

$$T_{Winding} = \Delta T + T_{Amb}$$

$$T_{Winding} = 11 \text{ K} + 22 \text{ °C} = 33 \text{ °C}$$

This calculation confirms that the temperature is well within the specified standard operating temperature range as well as the maximum winding temperature.

The calculation given above is for the purposes of a quick estimation only. The non-linear effects of temperature on the resistance of the winding and the resulting torque constant (k_M) of the motor due to the temperature coefficient of the magnet material used have not been taken into account and can have a large effect on motor performance at higher temperatures. A more detailed calculation should be performed before operating the motor close to its thermal limits.

Motor characteristic curves

For a specific torque, the various parameters can be read on diagram 2.

To simplify the calculation, the influence of temperature and tolerances has deliberately been omitted.

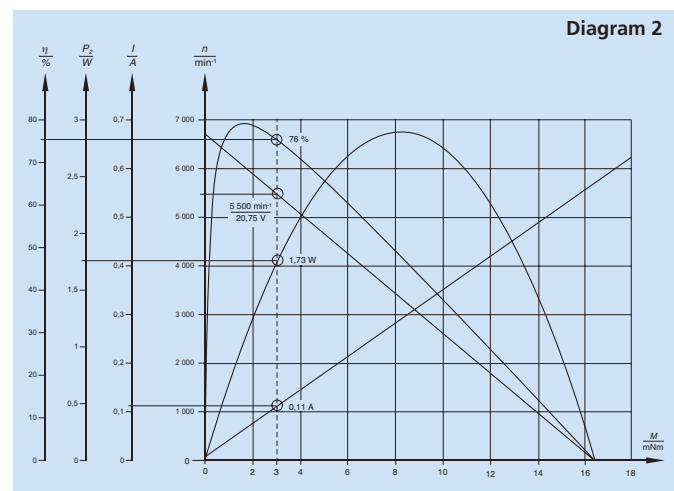

DC-Micromotors

Basic design

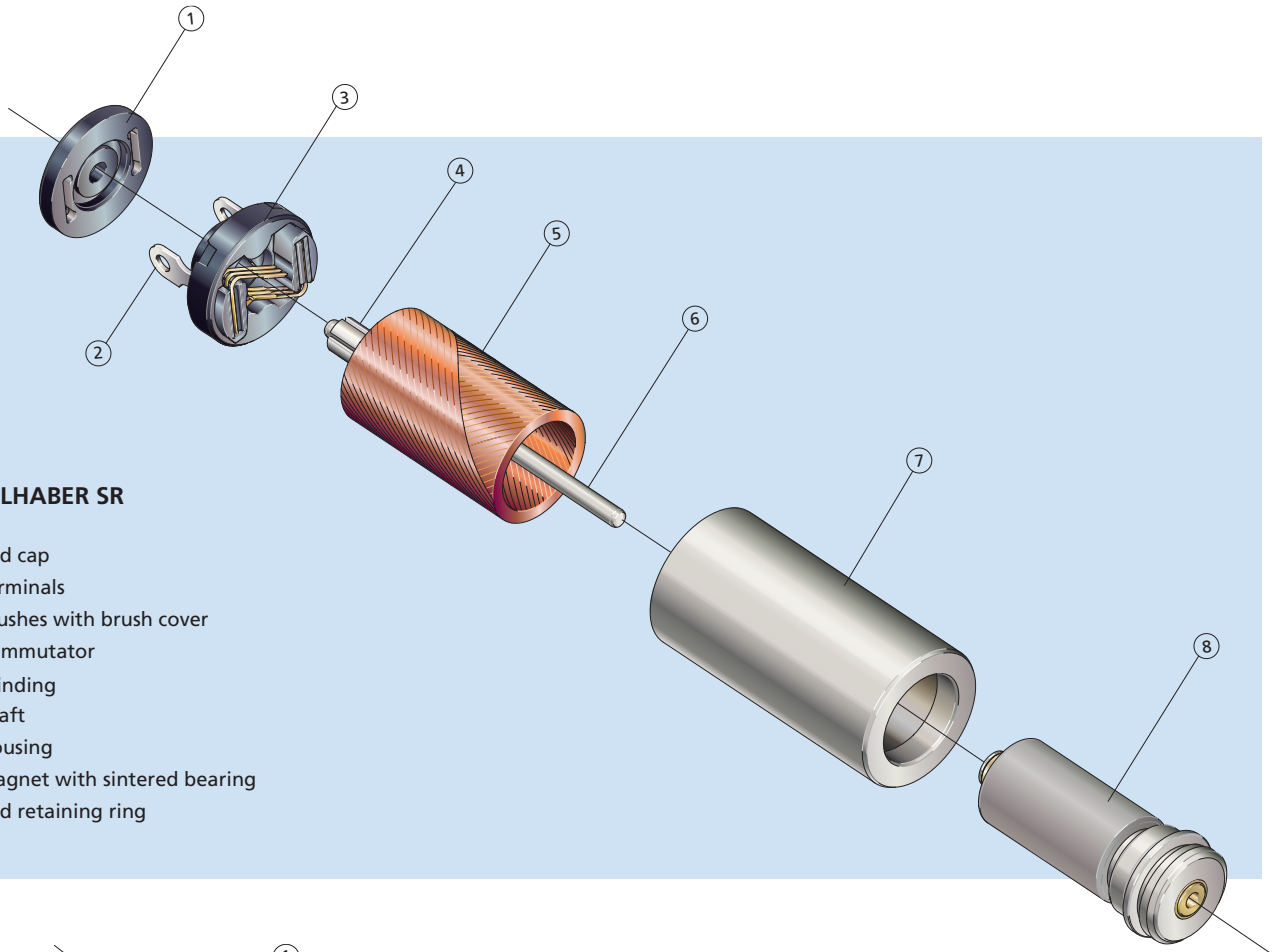

FAULHABER SR

- ① End cap
- ② Terminals
- ③ Brushes with brush cover
- ④ Commutator
- ⑤ Winding
- ⑥ Shaft
- ⑦ Housing
- ⑧ Magnet with sintered bearing and retaining ring

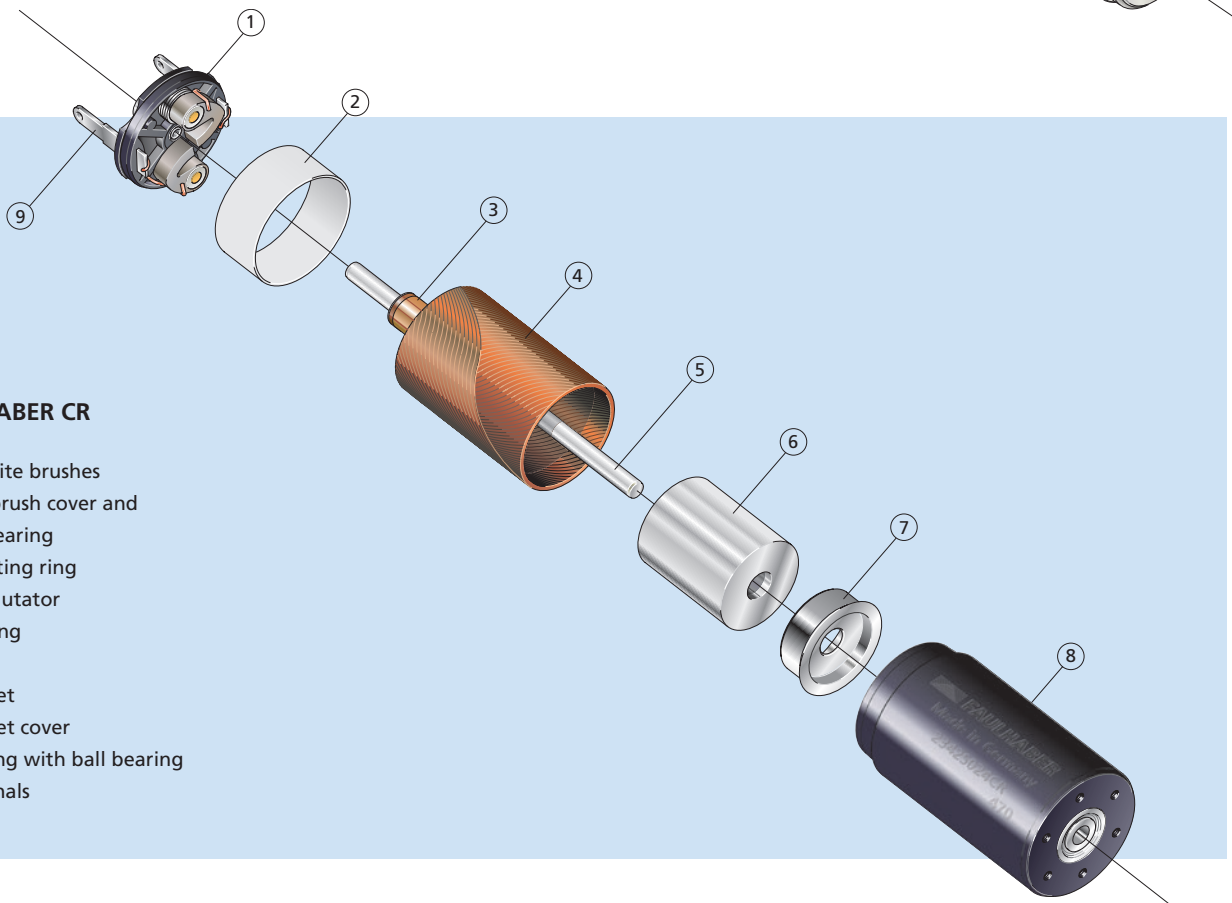

FAULHABER CR

- ① Graphite brushes with brush cover and ball bearing
- ② Insulating ring
- ③ Commutator
- ④ Winding
- ⑤ Shaft
- ⑥ Magnet
- ⑦ Magnet cover
- ⑧ Housing with ball bearing
- ⑨ Terminals

Flat DC-Micromotors

Basic design

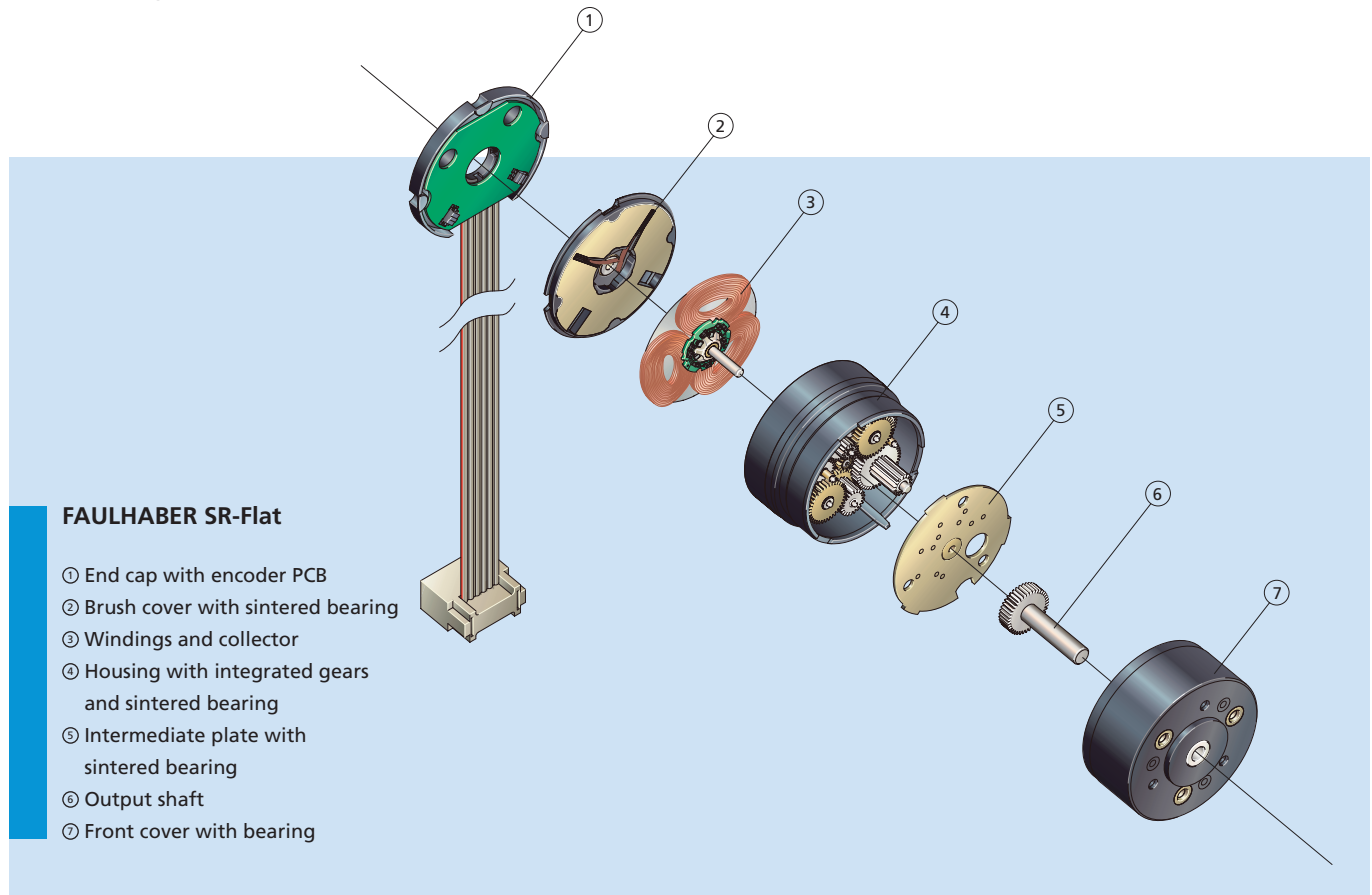

FAULHABER SR-Flat

- ① End cap with encoder PCB
- ② Brush cover with sintered bearing
- ③ Windings and collector
- ④ Housing with integrated gears and sintered bearing
- ⑤ Intermediate plate with sintered bearing
- ⑥ Output shaft
- ⑦ Front cover with bearing

Notes

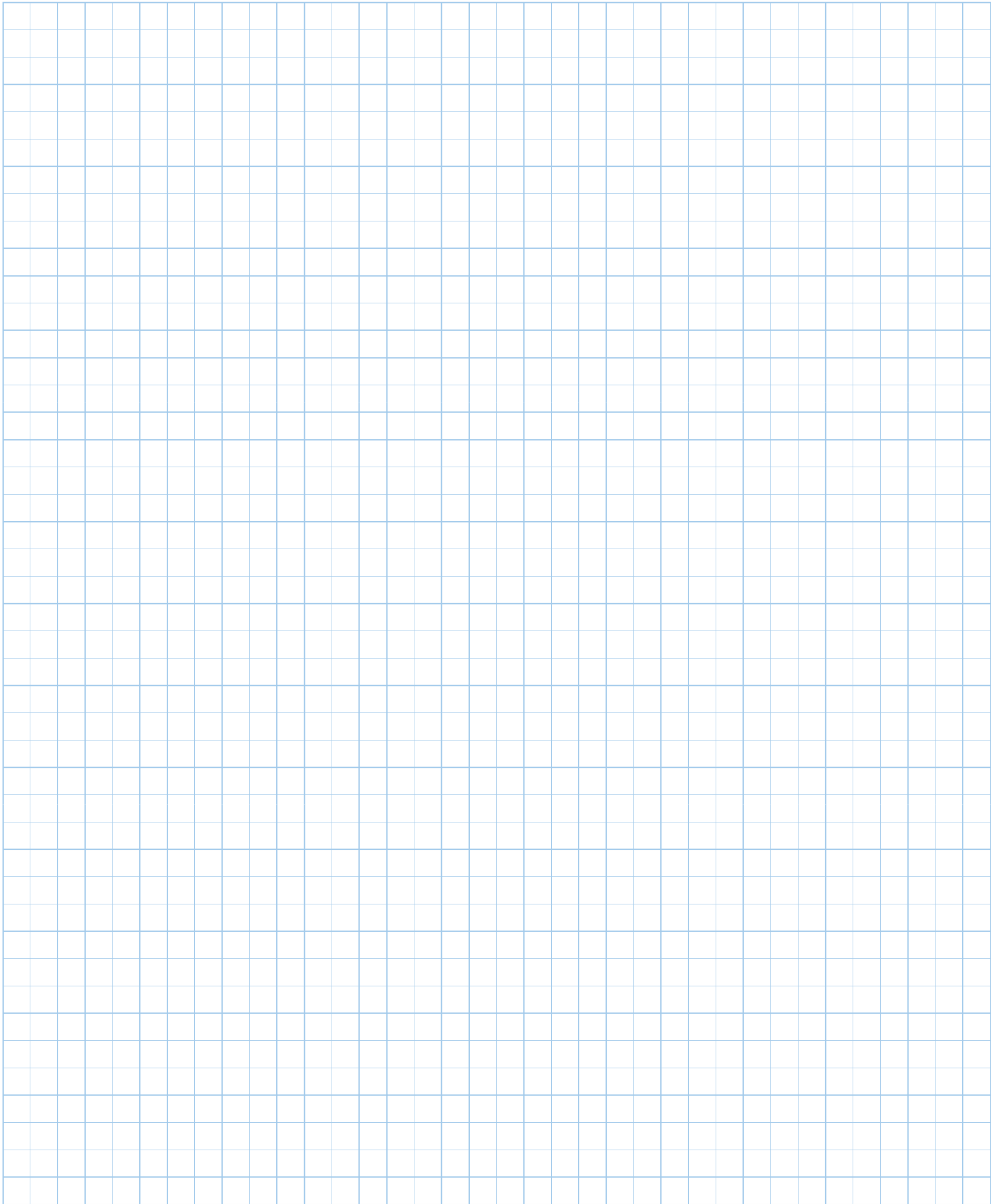

DC-Micromotors with precious metal commutation

Originally invented by Dr. Fritz Faulhaber Sr. and patented in 1958, the System FAULHABER coreless (or ironless) progressive, self-supporting, skew wound rotor winding is at the heart of every System FAULHABER DC Motor. This revolutionary technology changed the industry and created new possibilities for customer application of DC Motors where the highest power, best dynamic performance, in the smallest possible size and weight are required.

The main benefits of this technology include no cogging torque resulting in smooth positioning and speed control, higher overall efficiency than other DC Motor types, extremely high torque and power in relation to motor size and weight, and a linear relationship between load to speed, current to torque, and voltage to speed. The very low rotor inertia results in superior dynamic characteristics for starting and stopping and the motors exhibit extremely low torque ripple and EMI.



22 30 T 012 S

Series

0615 ... S	1219 ... G
1516 ... S	1624 ... S
2230 ... S	2233 ... S

Key Features

Motor diameter	6 ... 22 mm
Motor length	15 ... 33 mm
Nominal voltage	1,5 ... 40 V
Speed	up to 24.000 min ⁻¹
Torque	up to 5,9 mNm
Continuous output	up to 8 W

Product Code

22	Motor diameter [mm]
30	Motor length [mm]
T	Shaft type
012	Nominal voltage [V]
S	Product family

FAULHABER S/G

Advantages of this series at a glance

- Low torque ripple and high efficiency
- Wide operating temperature range
- No cogging torque
- Low current and starting voltage
- Compact and lightweight

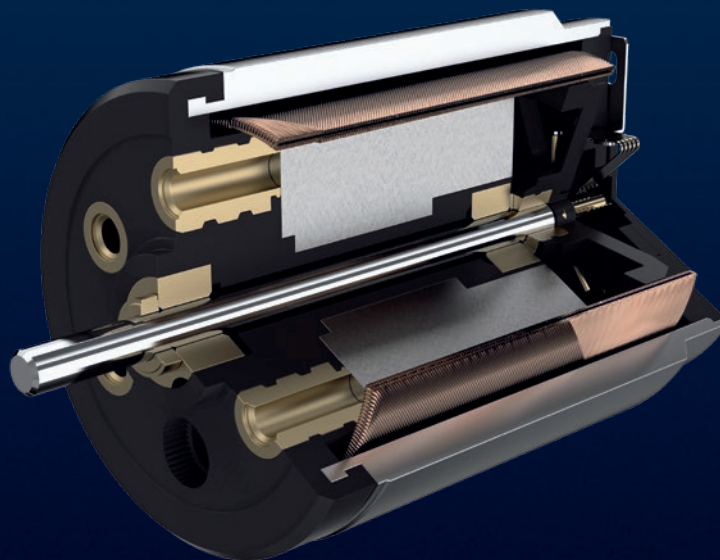

DC-Micromotors with precious metal commutation

These ironless DC motors are the most compact in the industry today and most types feature integrated high resolution encoders for use in highly precise positioning and speed control applications.

The commutation system is characterized by its small size, low contact resistance and clean low noise commutation signal. It is ideal for use in battery operated applications where current is at a premium.

Combinations with a wide variety of gearheads and controllers make it possible to create the best system solution for even the most challenging applications.

Series

0816 ... SR	1016 ... SR
1024 ... SR	1224 ... SR
1319 ... SR	1331 ... SR
1516 ... SR	1524 ... SR
1717 ... SR	1724 ... SR
2224 ... SR	2232 ... SR

Key Features

Motor diameter	8 ... 22 mm
Motor length	16 ... 32 mm
Nominal voltage	3 ... 36 V
Speed	up to 17.000 min ⁻¹
Torque	up to 10 mNm
Continuous output	up to 8,5 W

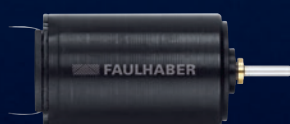

15 24 T 012 SR

Product Code

15	Motor diameter [mm]
24	Motor length [mm]
T	Shaft type
012	Nominal voltage [V]
SR	Product family

FAULHABER SR

Advantages of this series at a glance

- Powerful rare-earth magnets
- Wide operating temperature range:
-30 °C to +85 °C (optional -55 °C to +125 °C)
- All-steel housing with
corrosion-resistant coating
- Low torque ripple and high efficiency
- No cogging torque
- Low current and starting voltage
- Extremely compact and lightweight design
with integrated encoder

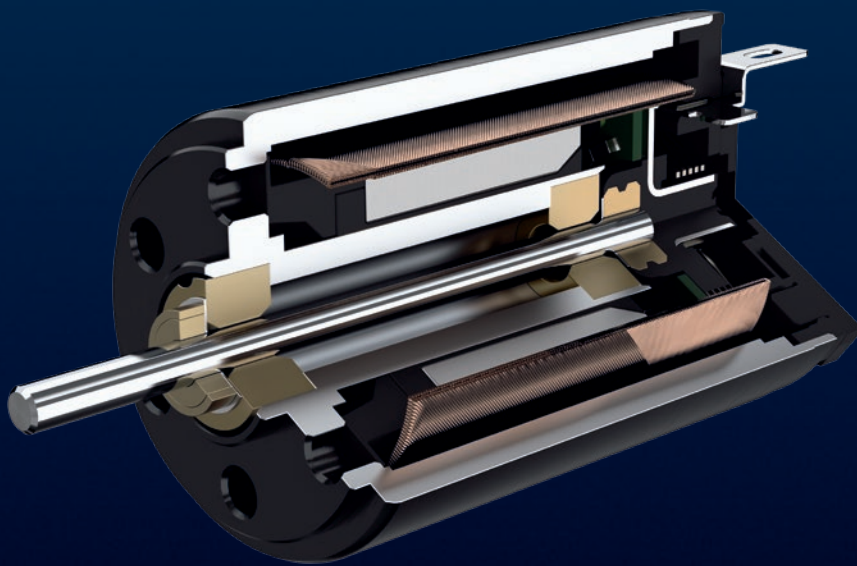

DC-Micromotors with graphite commutation

The CXR series combines power, robustness and control in a compact form. This is ensured by graphite commutation, high-quality neodymium magnets and the tried-and-tested winding of the FAULHABER rotor.

The powerful neodymium magnet gives the motors a high power density with a continuous torque ranging from 3.6 to 40 mNm. The impressive performance data and the compact size open up a wide spectrum of possible applications at an optimised price/performance ratio. The standard drive can be combined with high-resolution optical or magnetic encoders for applications with precise speed control or positioning tasks. A broad and optimally matched selection of gearheads is available to extend the range of requirements that this series is able to fulfil.

Series

1336 ... CXR	1727 ... CXR
1741 ... CXR	2237 ... CXR
2642 ... CXR	2657 ... CXR

Key Features

Motor diameter	13 ... 26 mm
Motor length	27 ... 57 mm
Nominal voltage	6 ... 48 V
Speed	up to 10.000 min ⁻¹
Torque	up to 40 mNm
Continuous output	up to 34 W

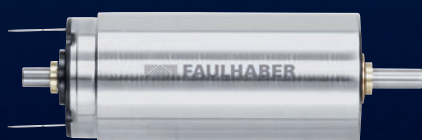

26 57 W 024 CXR

Product Code

26	Motor diameter [mm]
57	Motor length [mm]
W	Shaft type
024	Nominal voltage [V]
CXR	Product family

FAULHABER CXR

Advantages of this series at a glance

- Highly dynamic performance due to a low rotor inertia
- Shockproof all-steel housing with corrosion-resistant coating
- Powerful rare-earth magnet
- Wide operating temperature range: -30°C to +100°C (optional -55°C)
- Durable graphite commutation
- No cogging
- Very high power density

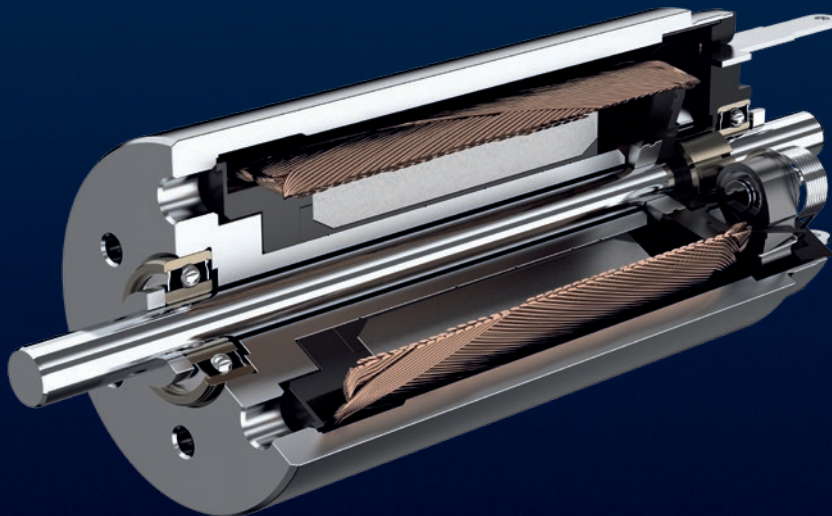

DC-Micromotors with graphite commutation

Highly stable and low-wear graphite commutation, extremely powerful neodymium magnets and a particularly high copper content in the winding of the FAULHABER rotor give the CR series its enormous power. The impressive power range of 19 to 224 mNm is ideal for high-performance applications with fast start/stop operation or periodic overload conditions. Thanks to the extremely high power density as well as the outstanding dynamics with minimal rotor inertia, the CR family is the most powerful product family of the entire FAULHABER DC range. The standard drive can be combined with high-resolution optical or magnetic encoders for applications with precise speed control or positioning tasks. A broad and optimally matched selection of gearheads is available to extend the range of requirements that this series is able to fulfil.

Series

2342 ... CR	2642 ... CR
2657 ... CR	2668 ... CR
3242 ... CR	3257 ... CR
3272 ... CR	3863 ... CR
3890 ... CR	

Key Features

Motor diameter	23 ... 38 mm
Motor length	42 ... 90 mm
Nominal voltage	6 ... 48 V
Speed	up to 11.000 min ⁻¹
Torque	up to 224 mNm
Continuous output	up to 160 W



Product Code

32	Motor diameter [mm]
72	Motor length [mm]
G	Shaft type
024	Nominal voltage [V]
CR	Product family

FAULHABER CR

Advantages of this series at a glance

- Best dynamic performance due to a low rotor inertia
- Shockproof all-steel housing with corrosion-resistant coating
- Powerful rare-earth magnet
- Extremely wide operating temperature range -30 °C to 125 °C (optionally -55 °C, winding up to 155 °C)
- Durable graphite commutation
- No cogging
- Highest power density

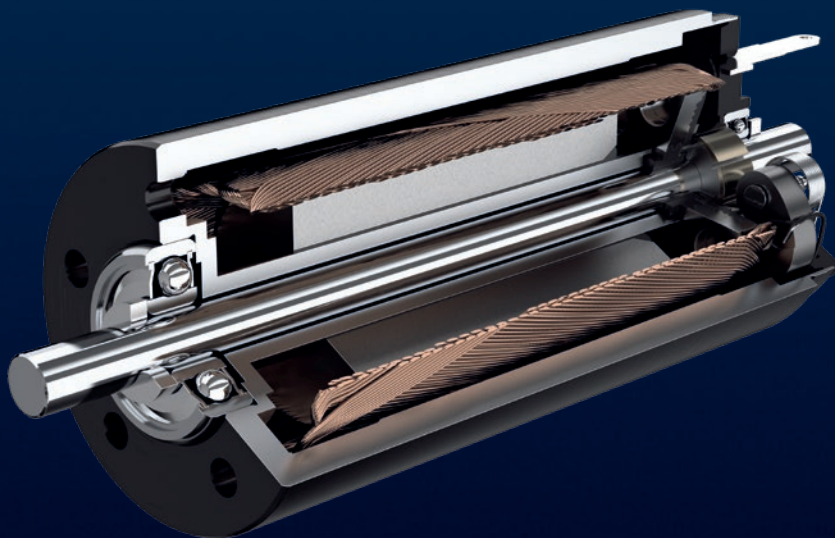

Flat DC-Micromotors and DC-Gearmotors

Precious-metal commutated DC-Micromotors with uniquely flat coil technology with three flat, self-supporting copper windings used in the SR-Flat series form the basis for drive systems in applications where space is extremely limited. With their powerful rare-earth magnets, the motors deliver a continuous output of 0.8 W to 4 W and at the same time have only minimal inertia. The motors are available with integrated gearheads and optical encoders – both with an extremely flat design matched to the motors. When combined with integrated gearheads and encoders, they provide a very compact drive system with increased output torque.

Series

1506 ... SR	1506 ... SR IE2-8
1512 ... SR	1512 ... SR IE2-8
2607 ... SR	2607 ... SR IE2-16
2619 ... SR	2619 ... SR IE2-16

Key Features

Motor diameter	15 ... 26 mm
Motor length	6 ... 19 mm
Nominal voltage	3 ... 24 V
Speed	up to 16.000 min ⁻¹
Torque	up to 100 mNm
Continuous output	up to 4 W

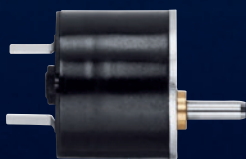

15 12 U 006 SR 324:1

Product Code

15	Motor diameter [mm]
12	Motor length [mm]
U	Shaft type
006	Nominal voltage [V]
SR	Product family
324:1	Gearhead reduction

FAULHABER SR-Flat

Advantages of this series at a glance

- Extremely flat design.
Lengths ranging from 6 mm to 19 mm
- 4-pole design
- Minimal moment of inertia
- Integrated spur gearheads of minimal length with high gear ratio are available
- Available with integrated optical encoders

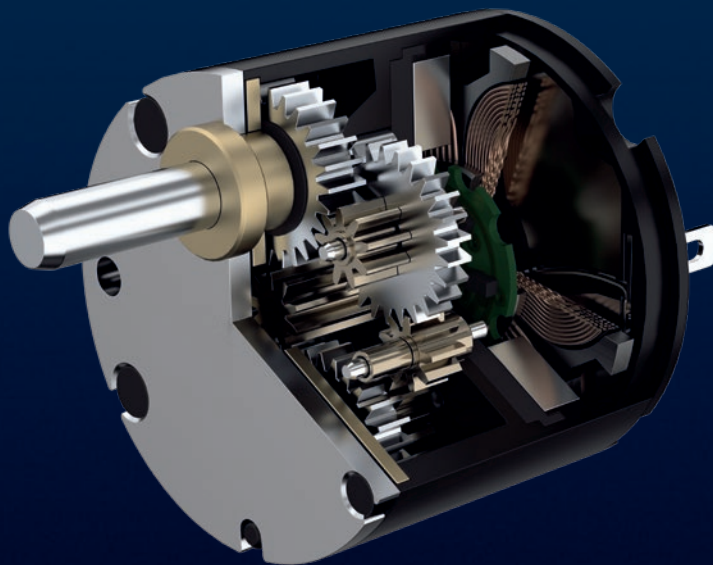

Brushless DC-Motors



Brushless DC-Servomotors

Technical Information

General information

The FAULHABER winding:

Originally invented by Dr. Fritz Faulhaber Sr. and patented in 1958, the System FAULHABER coreless (or ironless) progressive, self-supporting, skew-wound rotor winding is at the heart of every FAULHABER DC-Motor. This revolutionary technology changed the industry and created new possibilities for customer application of DC-Motors where the highest power, best dynamic performance, in the smallest possible size and weight are required. Applied in a three phase brushless motor, the winding no longer rotates but rather becomes the basis of a slotless stator. The main benefits of this technology include:

- No cogging torque resulting in smooth positioning and speed control and higher overall efficiency than other brushless motor types
- Extremely high torque and high performance in relation to the size and weight of the motor
- Absolute linear relationship between load to speed, current to torque, and voltage to speed, with a highly sensitive current/torque behaviour
- Extremely low torque ripple

Brushless DC-Motor Types:

Whether it's high torque 4-pole DC-Servomotors, highly efficient flat DC-Micromotors, or compact slotless motors, FAULHABER specializes in getting the most performance out of the smallest package.

Due to their design FAULHABER Brushless DC-Motors are ideal for heavy duty servo applications with frequent overload conditions as well as for continuous duty applications where maximum operational lifetime is required.

FAULHABER high precision 2-pole Brushless DC-Motors are three phase slotless motors that have a wide speed and torque range and are ideal for mid- to high speed applications requiring smooth speed control, high efficiency, and long operational lifetimes.

FAULHABER BHx motors are three phase slotless brushless motors designed for the very highest power to volume ratio and peak efficiency for cool operation even at very high speed. They feature a six phase coil connected for three phase operation which give the motors a significant boost in motor performance with no reduction in efficiency. They are designed for high to very high speed operation. They are available in high speed (BHS) and high torque (BHT) versions to maximize the speed or torque available in a given application.

For highly dynamic servo applications requiring very high torque in the most compact dimensions, the FAULHABER BX4 and BP4 Series 4-pole, DC-Servomotors are ideal. Their robust design with very few parts and no glued components means that they are extremely durable and well suited for challenging ambient conditions such as extreme temperatures and high shock and vibration loads.

The FAULHABER BP4 family of 4-pole slotless brushless motors are ideal for applications requiring the highest peak torque and extremely dynamic motion control.

FAULHABER Brushless DC-Flat Motors are 3 phase, slotless, axial flux gap motors with a rotating back iron. They have a much higher efficiency than other flat brushless motors and their rotating back iron provides a high rotor inertia that is ideal for applications requiring low torque ripple and very precise continuous speed control.

The FAULHABER BXT family of flat slotted brushless motors offer the highest possible torque in a very compact design.

FAULHABER also offers a range of 2-pole Brushless Motors with a cylindrical rotating back iron sometimes referred to as ironless external rotor motors. What sets the FAULHABER Motor apart is the slotless design which eliminates the cogging effect. The high inertia rotor makes these motors ideal for continuous duty applications requiring very precise speed control. These motors also have on-board speed control electronics that can be configured for different speed profiles.

Sensors:

FAULHABER 2-pole or 4-pole DC-Servomotors and Brushless DC-Flat Motors come standard with 3 discrete digital Hall sensors with a 120° phase shift.

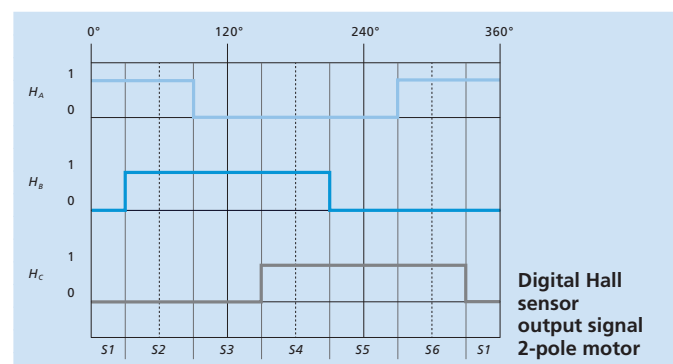

Brushless DC-Servomotors

Technical Information

As an option, most FAULHABER Brushless DC-Servomotors are available with analog (linear) Hall sensors.

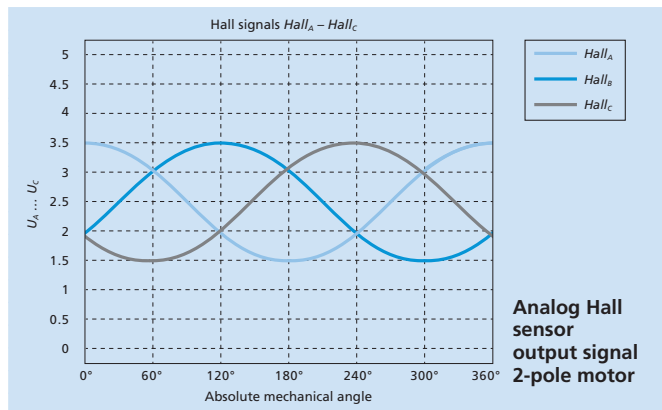

These sensors can replace the need for a high resolution encoder in many applications and provide the basic commutation signal for the Brushless DC-Servomotors in combination with FAULHABER Motion Controllers.

In some cases, for example, the FAULHABER BHx family, discrete sensors are replaced by a commutation PCB which provide the hall signals but can, in some cases, also provide sinusoidal commutation signals.

Magnets:

FAULHABER Brushless DC-Servomotors are designed with a variety of different types of magnets to suit the particular performance of the given motor type or application conditions. These materials include high performance rare earth magnet types such as SmCo and NdFeB.

Service life:

Due to the fact that motor commutation is achieved electronically and not mechanically, the operational lifetime of a FAULHABER Brushless DC-Servomotor depends mainly on the lifetime performance of the motor bearings. FAULHABER uses high precision preloaded ball bearings in all of its Brushless DC-Servomotors 6 mm in diameter and larger. Factors affecting the life of the motor bearings include the static and dynamic axial and radial bearing loads, the ambient thermal conditions, the motor speed, shock and vibrational loads, and the precision of the shaft coupling to the given application. If operated according to the data sheet Brushless DC-Servomotors have an operational lifetime many times that of mechanically commutated (brush) DC-Motors.

Modifications:

FAULHABER specialises in the adaptation of its standard products for customer-specific applications. Available modifications for FAULHABER Brushless DC-Servomotors include:

- Additional voltage types
- Connecting cables (PTFE and PVC) and plugs
- Configurable shaft lengths and second shaft ends
- Modified shaft dimensions and pinion configurations such as flats, gears, pulleys and eccenters
- Extended temperature range
- Vacuum compatibility (e.g. 10^{-5} Pa)
- Modifications for high speed and/or high load applications
- Modifications for high shock & vibration loads
- Autoclavable Motors
- Modifications for motors with tighter than standard electrical or mechanical tolerances

Product Combinations:

FAULHABER offers the industry's largest selection of complementary products tailor made for all of its Brushless DC-Servomotors including:

- Precision gearheads (planetary gearheads, spur gearheads and zero-backlash spur gearheads)
- High resolution Encoders (Incremental and Absolute)
- High Performance Drive Electronics (Speed Controllers, Motion Controllers)
- Integrated drive electronics (Motion and Speed Control)

Brushless DC-Servomotors

2 Pole Technology

Series 1628 ... B

Values at 22°C and nominal voltage		1628 T
1	Nominal voltage	U_N
2	Terminal resistance, phase-phase	R
3	Efficiency, max.	η_{max}
4	No-load speed	n_0
5	No-load current, typ. (with shaft \varnothing 1,5 mm)	I_0
6	Stall torque	
7	Friction torque	

Notes on technical datasheet

The following values are measured or calculated at nominal voltage, without integrated drive electronics, at an ambient temperature of 22 °C. Not all specifications are given for all motor types and will vary due to the motor technology and type.

Nominal voltage U_N [V]

This is the voltage applied between two winding phases using block commutation. This is the voltage at which the other data sheet parameters are measured or calculated. Depending on the required speed, higher or lower voltage can be applied to the motor within the given limits.

Terminal resistance, phase to phase R [Ω] ± 12 %

Is the resistance between two motor phases without an additional cable. This value will vary with the winding temperature (temperature coefficient: $\alpha_{22} = 0,004 \text{ K}^{-1}$).

Efficiency η_{max} [%]

The maximum ratio between the absorbed electrical power and the obtained mechanical power of the motor.

$$\eta_{max} = \left(1 - \sqrt{\frac{I_0 \cdot R}{U_N}}\right)^2$$

No-load speed n_0 [min^{-1}] ± 12 %

Describes the motor speed under no-load conditions at steady state and 22 °C ambient temperature. If not otherwise defined the tolerance for the no-load speed is assumed to be ± 12 %.

$$n_0 = \frac{U_N - (I_0 \cdot R)}{2\pi \cdot k_M}$$

No-load current, typ. I_0 [A]

Describes the typical current consumption of the motor without load at an ambient temperature of 22 °C after reaching a steady state condition.

The no-load current is speed and temperature dependent.

Changes in ambient temperature or cooling conditions will influence the value. In addition, modifications to the shaft, bearing, lubrication, and commutation system or combinations with other components such as gearheads or encoders will all result in a change to the no-load current of the motor.

Stall torque M_H [mNm]

The torque developed by the motor at zero speed (locked rotor) and nominal voltage. This value may vary due to the magnet type and temperature and the temperature of the winding.

Starting torque M_A [mNm]

Maximum torque that the motor can produce at room temperature and nominal voltage for a short time during startup. This value can change due to possible current limits in the control electronics.

Both the stall torque M_H and the starting torque M_A can be approximated using the following formula:

$$M_H = M_A = k_M \cdot \frac{U_N}{R} - C_0$$

Friction torque C_0 [mNm]

The torque caused by static mechanical friction of the ball bearings and magnetic hysteresis of the stator.

Viscous damping factor C_V [$\text{mNm}/\text{min}^{-1}$]

This factor is made up of the torque due to the viscous friction of the ball bearings as well as the Foucault currents, caused by the cyclical changes in the magnetic field of the stator. These losses are proportional to the speed of the motor.

Speed constant k_n [min^{-1}/V]

The speed variation per Volt applied to the motor terminals at constant load.

$$k_n = \frac{n_0}{U_N - I_0 \cdot R} = \frac{1}{k_E}$$

Back-EMF constant k_E [$\text{mV}/\text{min}^{-1}$]

The constant corresponding to the relationship between the induced voltage in the rotor and the speed of rotation.

$$k_E = 2\pi \cdot k_M$$

Torque constant k_M [mNm/A]

The constant corresponding to the relationship between the torque developed by the motor and the current drawn.

Brushless DC-Servomotors

Technical Information

Current constant k_t [A/mNm]

Describes the relation of the current in the motor winding and the torque developed at the output shaft.

$$k_t = \frac{1}{k_M}$$

Slope of n-M curve $\Delta n / \Delta M$ [min⁻¹/mNm]

The ratio of the speed variation to the torque variation. The smaller the value, the more powerful the motor.

$$\frac{\Delta n}{\Delta M} = \frac{R}{k_M^2} \cdot \frac{1}{2\pi}$$

Terminal inductance, phase to phase L [μ H]

The inductance measured between two phases at 1 kHz.

Mechanical time constant τ_m [ms]

The time required by the motor to reach a speed of 63 % of its final no-load speed, from standstill.

$$\tau_m = \frac{R \cdot J}{k_M^2}$$

Rotor inertia J [gcm²]

The dynamic moment of inertia of the rotor.

Angular acceleration α_{max} [rad/s²]

The acceleration obtained from standstill under no-load conditions and at nominal voltage.

$$\alpha_{max} = \frac{M_H}{J}$$

Thermal resistance R_{th1} ; R_{th2} [K/W]

R_{th1} corresponds to the thermal resistance between the winding and housing. R_{th2} corresponds to the thermal resistance between the housing and the ambient air. R_{th2} can be reduced by enabling exchange of heat between the motor and the ambient air (for example, a thermally coupled mounting configuration, using a heat sink, and/or forced air cooling).

Thermal time constant τ_{w1} ; τ_{w2} [s]

The thermal time constant specifies the time needed for the winding (τ_{w1}) and housing (τ_{w2}) to reach a temperature equal to 63 % of final steady state value.

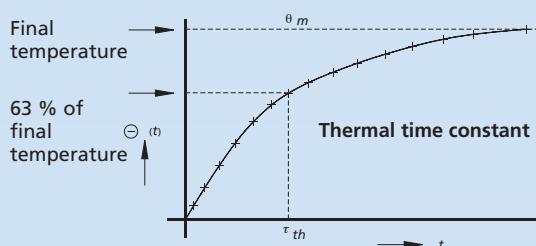

Operating temperature range [°C]

Indicates the minimum and maximum standard motor operating temperature, as well as the maximum allowable temperature of the standard motor winding.

Shaft bearings

The bearings used for the Brushless DC-Servomotor.

Shaft load max. [N]

The output shaft load at a specified shaft diameter for the primary output shaft. For motors with ball bearings the load and lifetime are in accordance with the values given by the bearing manufacturers. This value does not apply to second, or rear shaft ends.

Shaft play [mm]

The play between the shaft and bearings, including the additional bearing play in the case of ball bearings.

Housing material

The housing material and the surface protection.

Mass [g]

The average mass of the basic motor type.

Direction of rotation

Most motors are designed for clockwise (CW) and counter-clockwise (CCW) operation; the direction of rotation is reversible.

Please note that for motors with integrated electronics, the direction of rotation may not be reversible.

Speed up to n_{max} [min⁻¹]

The maximum recommended motor speed for continuous operation at a given cooling level. This value is based on the recommended operating range for the standard motor bearings and the winding. All higher values have negative effects on the maximum achievable service life of the motor.

Number of pole pairs

Indicates the number of pole pairs of the standard motor.

Hall sensors

Describes the type of motor commutation feedback components in the standard motor.

Magnet material

Describes the basic type of the magnet used in the standard motor.

Unspecified mechanical tolerances:

Tolerances in accordance with ISO 2768.

≤ 6 = ± 0,1 mm

≤ 30 = ± 0,2 mm

≤ 120 = ± 0,3 mm

The tolerances of non-specified values are available on request.

All mechanical dimensions related to the motor shaft are measured with an axial preload of the shaft toward the motor.

Autoclavable

FAULHABER Brushless DC Motors specified "for Autoclave Sterilisation" have been specifically designed to withstand steam sterilization processes. The sterilization cycle used as reference is the following:

Reference Autoclave Sterilization Cycle:

Sterilizer, Pulse Vacuum Steam Sterilizer

Air Removal Pre Vacuum	ca. 0,9 mbar
Holding Temperature	134 °C
Holding Pressure	2100 mbar
Relative Humidity	100 %
Holding Time	18 minutes
Vacuum Drying	ca. 0,9 mbar

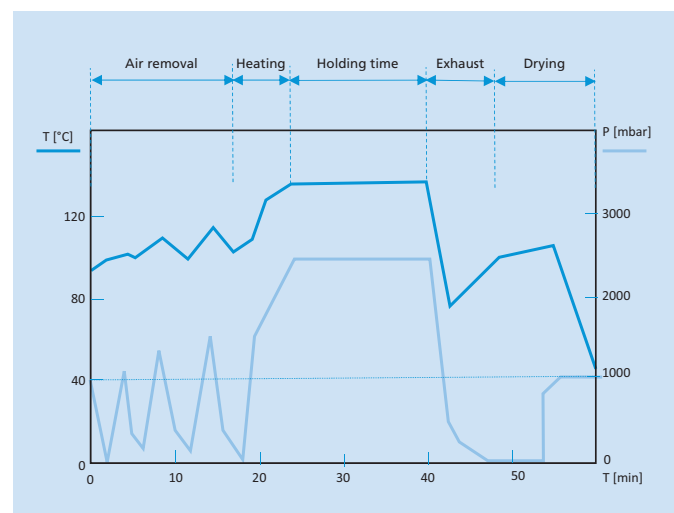

The above mentioned sterilization cycle does not include any preparation activities such as cleaning or disinfection. The typical number of cycles that the brushless DC motor will withstand is indicated in the datasheet. This value could be exceeded if the motor is encapsulated in the final assembly.

Brushless DC-Servomotors

Technical Information

Rated values for continuous duty operation

The following values are measured at nominal voltage, without integrated drive electronics, at an ambient temperature of 22 °C.

Rated Torque M_N [mNm]

The maximum continuous duty torque (S1 Operation) at nominal voltage resulting in a steady state temperature not exceeding either the maximum winding temperature and/or operating temperature range of the motor. Additionally the motors are specified either with a 25 % reduction of the R_{th2} value or with an additional mounting condition on a metal flange. Both types of diagram approximate the cooling of the motor given by a typical method of installation. This value can be exceeded if the motor is operated intermittently, for example, in S2 mode and/or if more cooling is applied.

Rated Current (thermal limit) I_N [A]

The typical maximum continuous current at steady state resulting from the rated continuous duty torque. This value includes the effects of a loss of k_M (torque constant) as it relates to the temperature coefficient of the winding, losses due to the effects of the dynamic coefficient of friction which include the Foucault (eddy current) losses, as well as the thermal characteristics of the given magnet material. This value can be exceeded if the motor is operated intermittently, in start/stop mode, in the starting phase and/or if more cooling is used.

Rated Speed n_N [min⁻¹]

The typical speed at steady state resulting from the application of the given rated torque. This value includes the effects of motor losses on the slope of the n/M curve.

Rated Slope of the n - M curve

An approximation of the slope of the curve at a given rated operating point. This value is derived from the no load speed and the speed under load.

$$\frac{n_0 - n_N}{M_N}$$

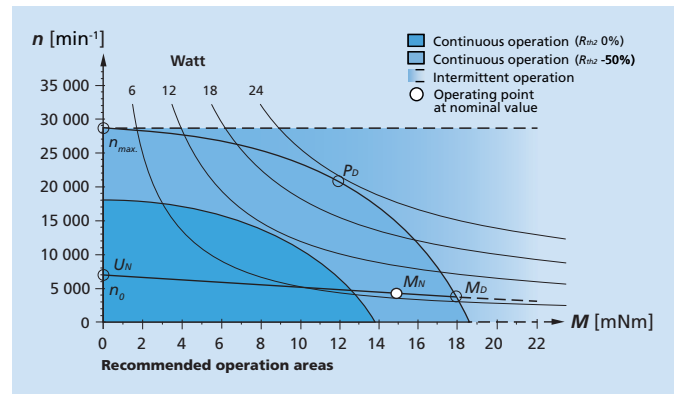

Example: Power diagram for rated values at continuous operation.

Explanations on the performance diagram

The performance diagram shows the range of possible operating points of a drive at an ambient temperature of 22 °C and includes both the operation in the thermally insulated and in the cooled state. The possible speed ranges are shown in dependence on the shaft torque.

The sector shown dashed describes potential operating points in which the drive can be engaged in intermittent operation or with increased cooling.

Continuous torque M_D [mNm]

Describes the max. continuous torque in the steady state at nominal voltage and with a thermal reduction of the R_{th2} value by 50 %. The continuous speed decreases linearly vis-à-vis the continuous torque. In the case of slotted flat brushless motors, this point is indicated with the motor mounted on a metal flange and is the same as M_N . The continuous torque is independent of the continuous output power and can be exceeded if the motor is operated intermittently, for example, in S2 operation and/or if more cooling is applied.

Continuous output power P_D [W]

Describes the max. possible output power in continuous operation in steady state with a thermal reduction of the R_{th2} value by 50 %. The value is independent of the continuous torque, responds linearly to the cooling factor and can be exceeded if the motor is operated intermittently, for example, in S2 operation and/or if more cooling is applied.

Nominal voltage curve U_N [V]

The nominal voltage curve describes the operating points at U_N in the uncooled and cooled state. In steady state, the starting point corresponds to the no-load speed n_0 of the drive. Operating points above this curve can be attained by an increase, operating points below by a reduction of the nominal voltage.

Additional Information for Slotted Brushless Motors

The performance curves for slotted motors with a housing will be significantly different than the diagrams of the motors without housing. Typically motors without a housing will have a higher performance due to the effects of ambient air flow cooling.

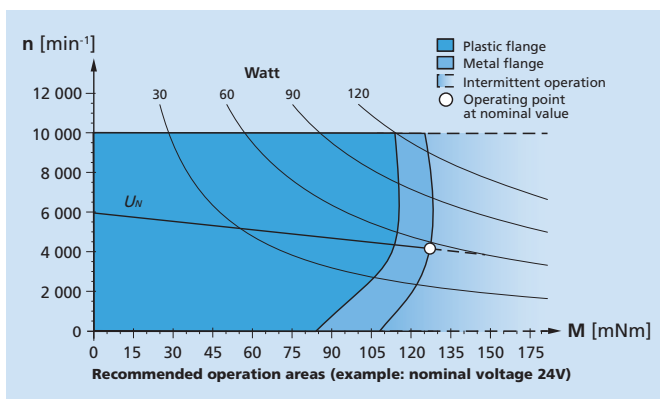

Example: Performance diagram for rated values with continuous operation. (BXT R)

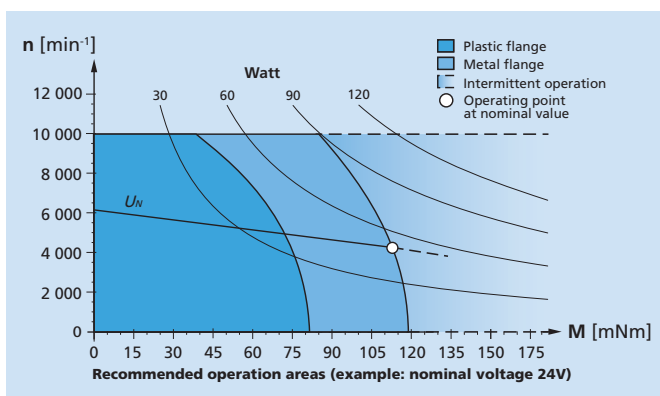

Example: Performance diagram for rated values with continuous operation. (BXT H)

Brushless DC-Servomotors

Basic design

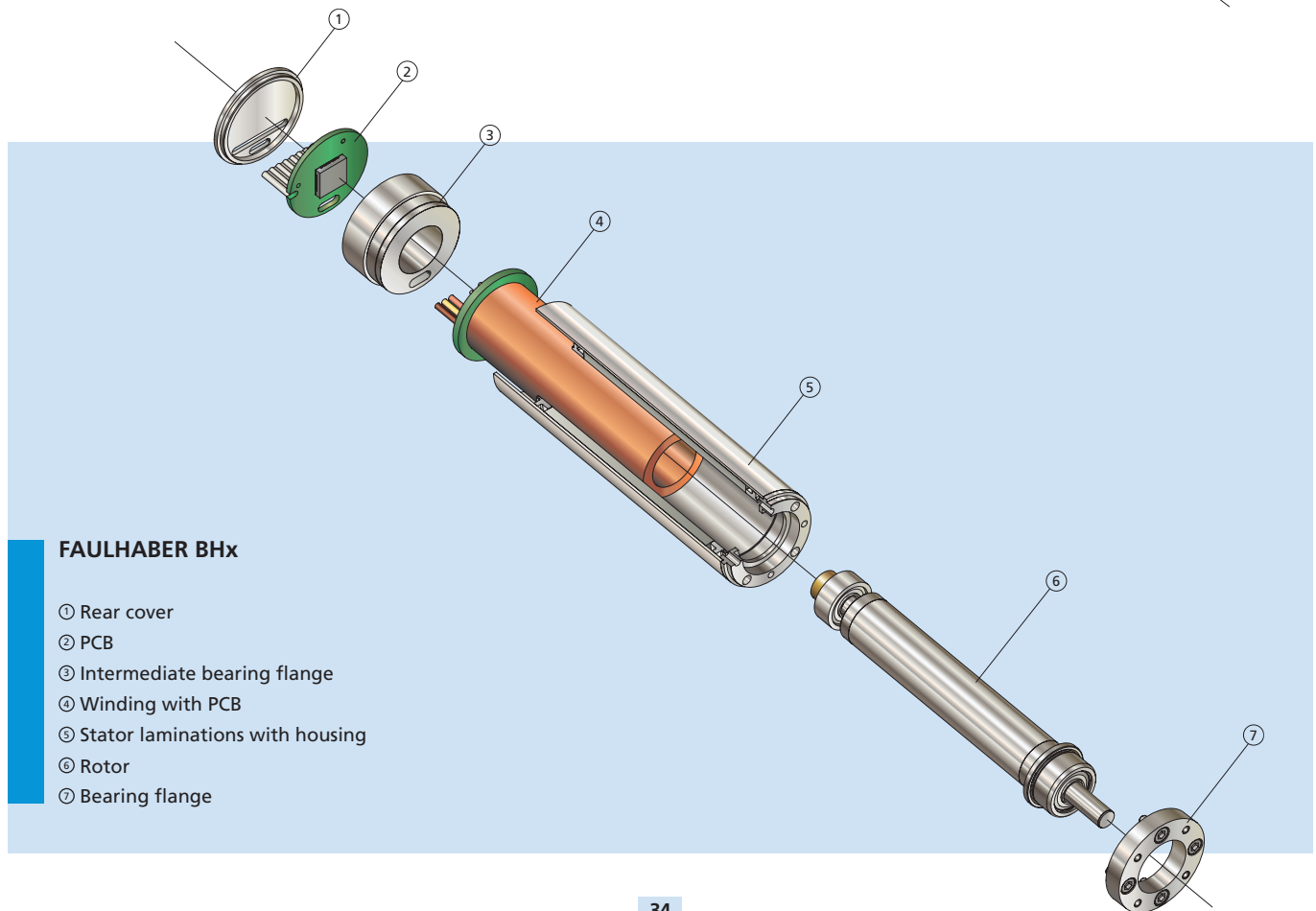
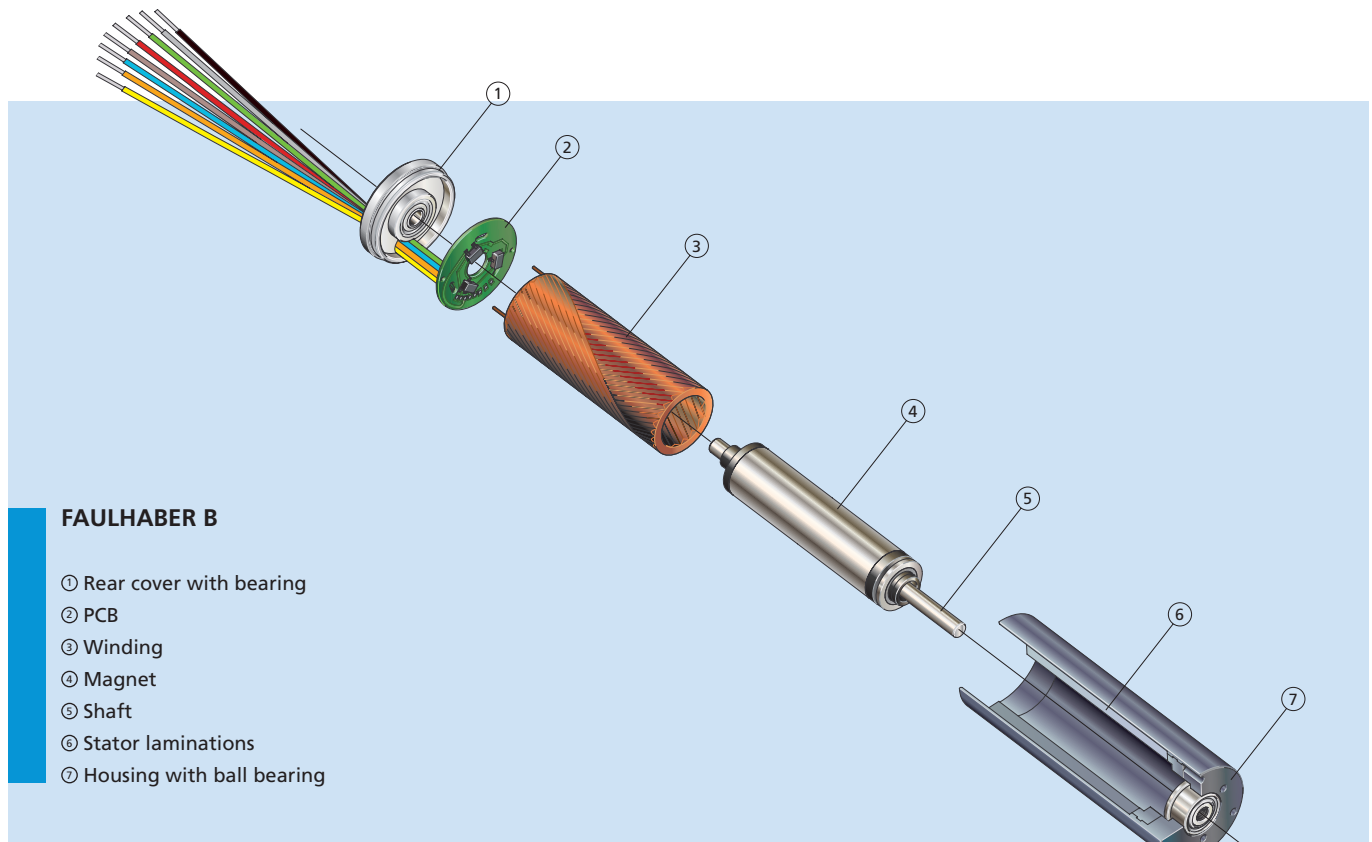

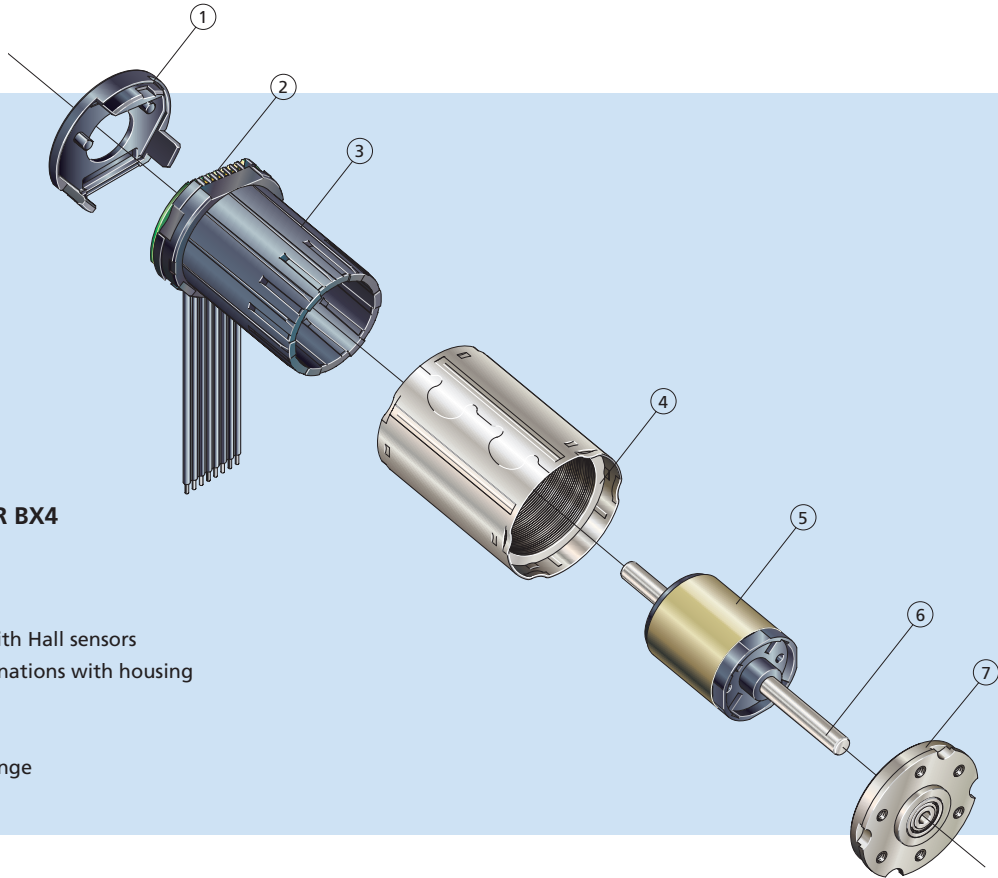
FAULHABER BX4

- ① Rear cover
- ② PCB
- ③ Winding with Hall sensors
- ④ Stator laminations with housing
- ⑤ Magnet
- ⑥ Shaft
- ⑦ Bearing flange

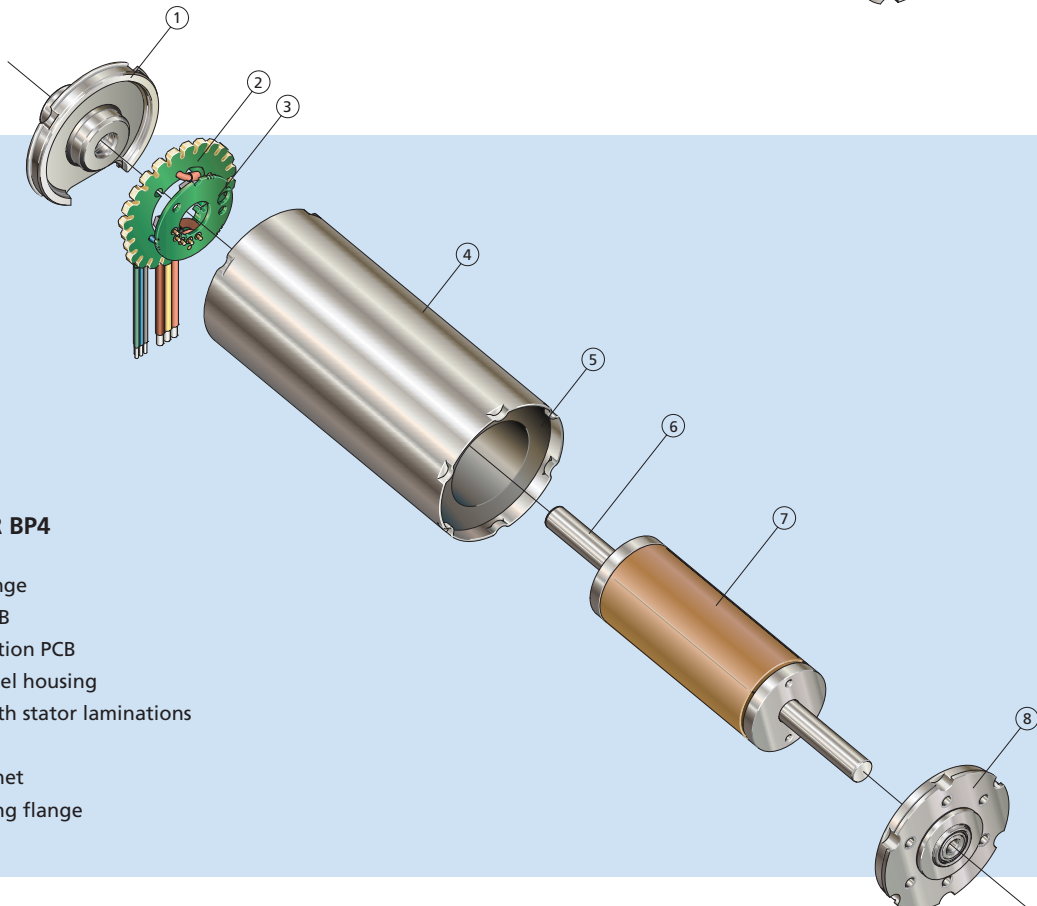
FAULHABER BP4

- ① Bearing flange
- ② Winding PCB
- ③ Hall connection PCB
- ④ Stainless steel housing
- ⑤ Winding with stator laminations
- ⑥ Shaft
- ⑦ 4 Pole magnet
- ⑧ Front bearing flange

Brushless Flat DC-Micromotors

Basic design

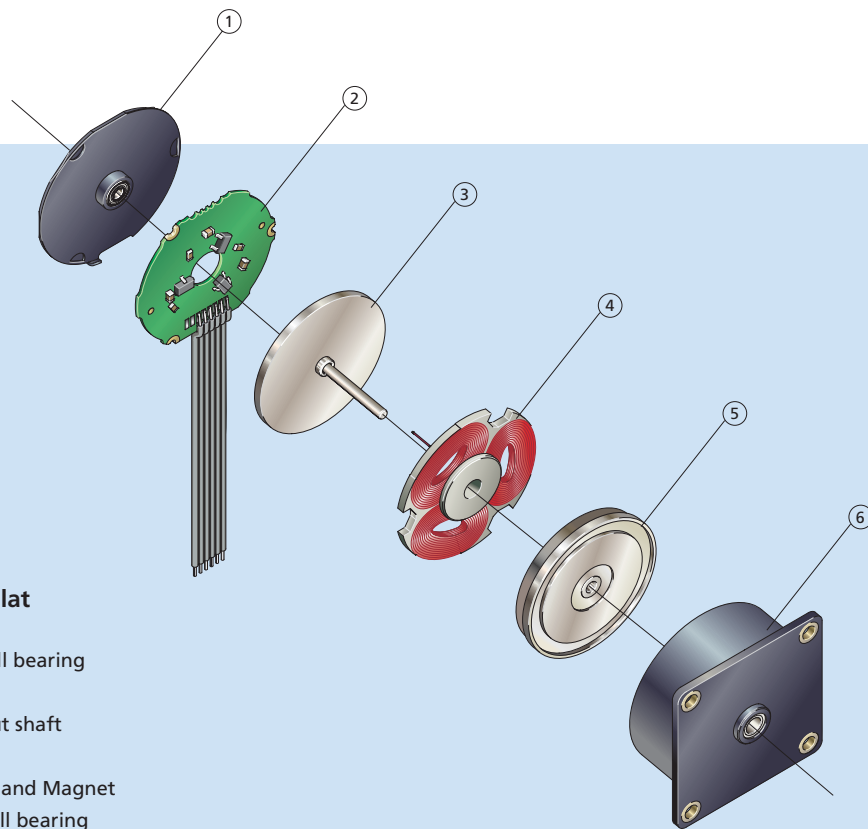

FAULHABER B-Flat

- ① End cap with ball bearing
- ② Hall Sensor PCB
- ③ Rotor and output shaft
- ④ Stator Winding
- ⑤ Rotor, Back-Iron and Magnet
- ⑥ Housing with ball bearing

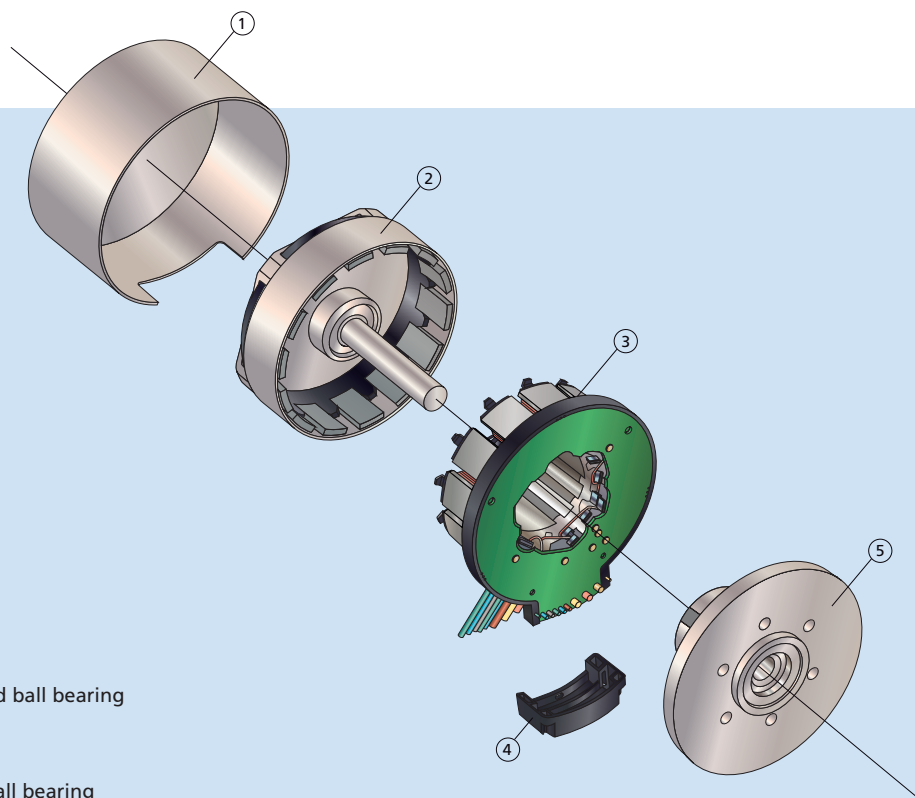

FAULHABER BXT

- ① Housing (for BXT H)
- ② Rotor with shaft and ball bearing
- ③ Stator with PCB
- ④ Cover
- ⑤ Front flange with ball bearing

Notes



Brushless DC-Servomotors 2 Pole Technology, sensorless

The brushless, sensorless DC-Servomotors can be used even in the most challenging applications where space is extremely limited. After many years of development and experience in microsystem technology, FAULHABER has succeeded in reducing the size of all components and modules to a minimum in order to provide reliable drive functions even with the smallest of dimensions. The brushless DC-Servomotors are sensorless and available with matching, highly compact gearheads for increasing the output torque, and speed controllers. The brushless DC-Servomotors provide a technology basis that can be modified for projects according to the requirements of the individual customer.

Series

0308 ... B 0515 ... B

Key Features

Motor diameter	3 ... 5 mm
Motor length	8 ... 15 mm
Nominal voltage	3 ... 6 V
Speed	up to 96.000 min ⁻¹
Torque	up to 0,13 mNm
Continuous output	up to 0,44 W



Product Code

05	Motor diameter [mm]
15	Motor length [mm]
G	Shaft type
006	Nominal voltage [V]
B	Product family

FAULHABER B-Micro

Advantages of this series at a glance

- Extremely compact design.
Diameters ranging from 3 mm to 5 mm
- For applications where space is very limited
- 2-pole design with medium to high speeds
- Matching, highly compact gearheads available
- Matching speed controllers available

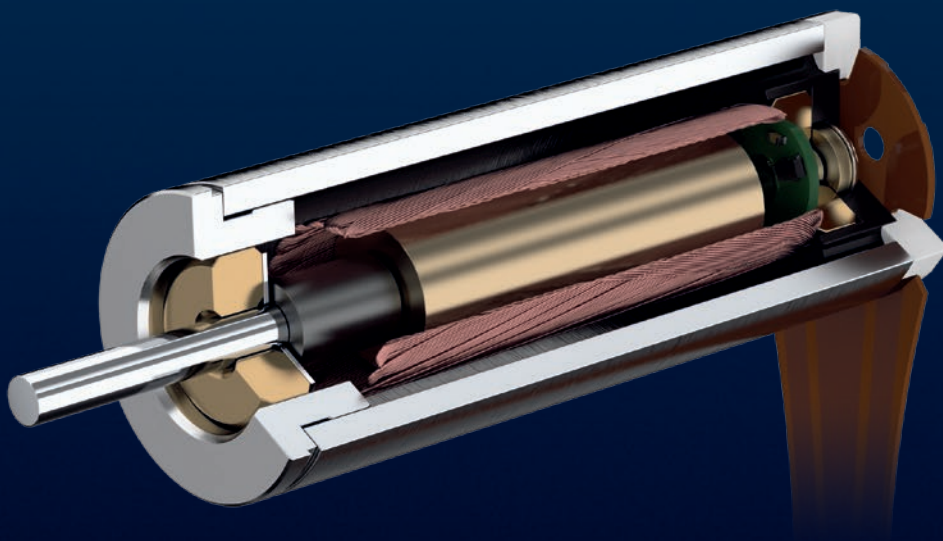

Brushless DC-Servomotors 2 Pole Technology

The original FAULHABER brushless DC servomotors. These ironless slotless motors are built for use in highly challenging areas of application and environmental conditions from the vacuum of space to medical device technology. They are precise, have extremely long operational lifetimes, and are highly reliable. They are available with a wide variety of complementary products such as high resolution encoders and precision gearheads. For maximum integration and reduction of size the standard digital hall sensors in the motors can be replaced with optional analog (linear) hall sensors which can eliminate the need for an encoder in most applications.

Series

0620 ... B	0824 ... B
1028 ... B	1218 ... B
1226 ... B	1628 ... B
2036 ... B	2057 ... B
2444 ... B	3056 ... B
3564 ... B	4490 ... B
4490 ... BS	

Key Features

Motor diameter	6 ... 44 mm
Motor length	18 ... 90 mm
Nominal voltage	24 ... 48 V
Speed	up to 100.000 min ⁻¹
Torque	up to 217 mNm
Continuous output	up to 282 W



Product Code

35	Motor diameter [mm]
64	Motor length [mm]
K	Shaft type
024	Nominal voltage [V]
B	Product family

FAULHABER B

Advantages of this series at a glance

- High density ironless system FAULHABER winding
- Extremely smooth speed control
- Digital or analog hall sensors available
- Sensitive positioning control

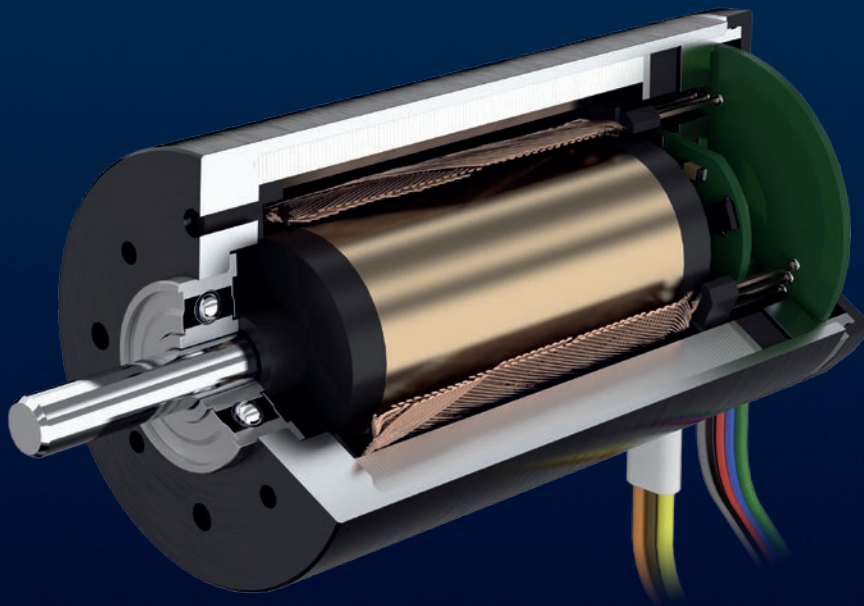

Brushless DC-Servomotors 2 Pole Technology

The BHx series uses 2-pole brushless technology based on an innovative and robust design to deliver high power in a compact size. These motors come in 2 distinct versions to support a wide variety of different application needs: the BHT variant is dedicated to high torque for large impulsive cycles, and the BHS model is focused on very high speed for continuous use.

BHx series is capable of driving variable load with minimum speed fluctuation to guarantee smooth behavior at constant speed. Furthermore their low inertia and short response time provide also high dynamics. Those characteristics make BHx series ideal for both-high speed operation and fast accurate positioning, especially in intermittent operation when combined with integrated high resolution encoder. BHx series exhibits low vibration level and low noise to reduce human fatigue and stress inside application environment. Their high efficiency minimizes heat generation and helps to increase comfort when used as handtools.

Series

1660 ... BHS	1660 ... BHT
--------------	--------------

Key Features

Motor diameter	16 mm
Motor length	60 mm
Nominal voltage	24 ... 48 V
Speed	up to 97.000 min ⁻¹
Torque	up to 18,7 mNm
Continuous output	up to 96 W

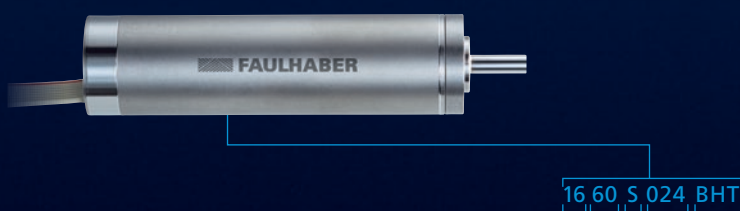

Product Code

16	Motor diameter [mm]
60	Motor length [mm]
S	Shaft type
024	Nominal voltage [V]
BHT	Product family

FAULHABER BHx

Advantages of this series at a glance

- Large power up to 96 W in small diameter
- High speed close to 100'000 min⁻¹ (BHS version)
- Huge impulsive torque > 30 mNm (BHT version)
- Very dynamic and responsive with low inertia
- Low vibration and low noise, suitable for handtools
- Optional integrated encoder

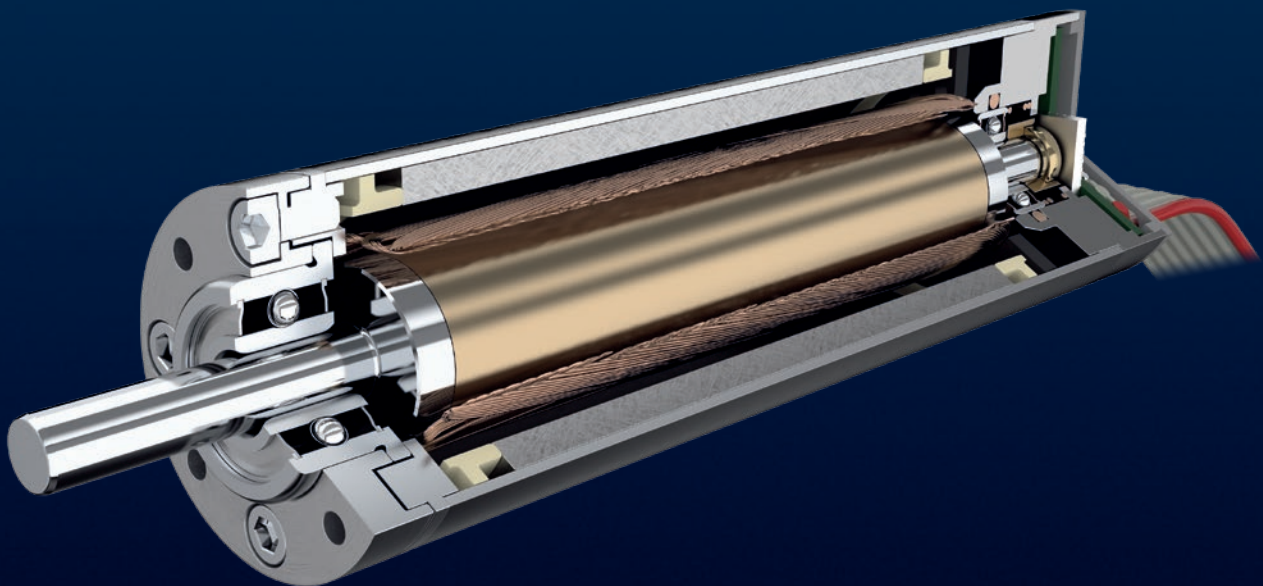

Brushless DC-Servomotors 4 Pole Technology

From dynamic start/stop operation to speed control and high-precision, integrated position control in confined installation spaces – the flexible BX4 modular system can be combined with a wide variety of gearhead and lead screw attachments and offers customised solutions for a broad range of different applications.

The long service life, high torque and an innovative as well as compact design are further outstanding features of this 4-pole product family.

Smooth running, low vibration and low noise mean that these motors can be used in sensitive markets, e.g. medical technology, in addition to market sectors such as automation technology, robotics and machine construction.

Series

2232 ... BX4	2250 ... BX4 S
2250 ... BX4	3242 ... BX4
3268 ... BX4	

Key Features

Motor diameter	22 ... 32 mm
Motor length	32 ... 68 mm
Nominal voltage	6 ... 48 V
Speed	up to 29.000 min ⁻¹
Torque	up to 96 mNm
Continuous output	up to 62 W



Product Code

22	Motor diameter [mm]
50	Motor length [mm]
S	Shaft type
024	Nominal voltage [V]
BX4	Product family

FAULHABER BX4

Advantages of this series at a glance

- High torque and speed rigidity thanks to 4-pole technology
- Position control in extremely confined installation spaces thanks to optional analogue Hall sensors
- Modular, diameter-compliant mounting concept for high-resolution magnetic and optical encoders
- Versions with integrated Speed or Motion Controllers available
- High reliability and long service life
- Dynamically balanced rotor, quiet running

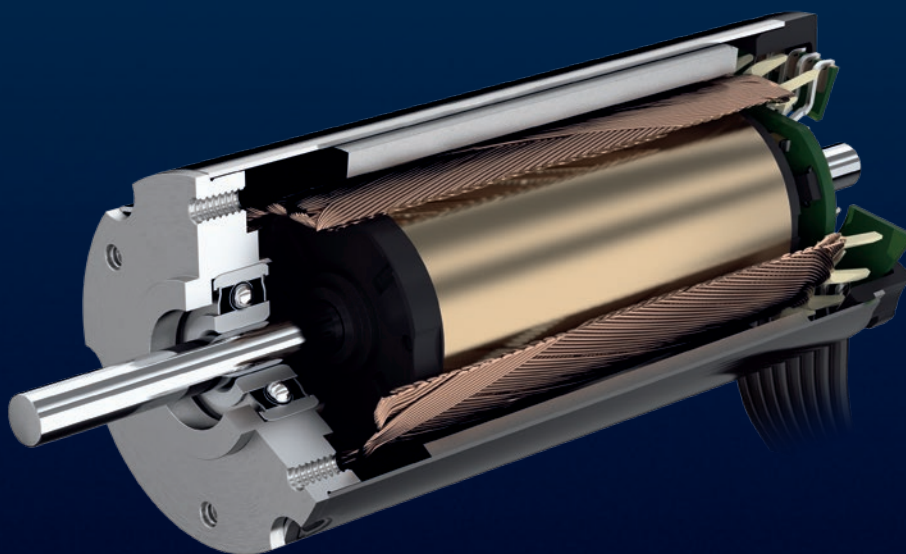

Brushless DC-Servomotors 4 Pole Technology

The four-pole brushless DC-Servomotors of the BP4 series are characterised by their extremely high torques, despite the compact 22 mm and 32 mm diameter design and low weight. At the heart of the motors lies innovative winding technology that not only allows a very high copper content in the stator, but also has a high electrical and geometric winding symmetry. This minimises losses and maximises efficiency. The BP4 series is overload-resistant and suitable for applications involving high power where the lowest possible total weight and smallest possible installation space are required, and also for dynamic start/stop operation.

Series

2264 ... BP4 3274 ... BP4

Key Features

Motor diameter	22 ... 32 mm
Motor length	64 ... 74 mm
Nominal voltage	12 ... 24 V
Speed	up to 34.500 min ⁻¹
Torque	up to 162 mNm
Continuous output	up to 150 W

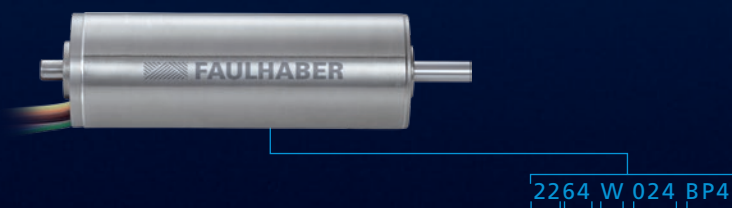

Product Code

22	Motor diameter [mm]
64	Motor length [mm]
W	Shaft type
024	Nominal voltage [V]
BP4	Product family

FAULHABER BP4

Advantages of this series at a glance

- High-power motors with maximum torque
- Continuous output from 133 W to 150 W
- Outstanding ratio of torque to weight and size
- Very high efficiency of up to 91 %
- Fully integrated analogue Hall sensors and matching encoders, gearheads and controllers are available
- For dynamic start/stop operation

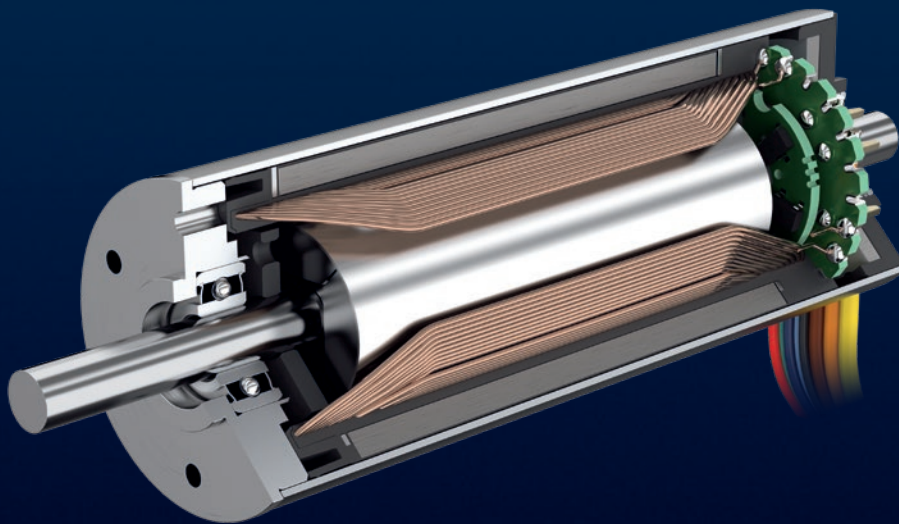

Brushless Flat DC-Micromotors and DC-Gearmotors

The four-pole brushless DC-Servomotors, which have uniquely flat coil technology with three flat, self-supporting copper windings and are used in the B-Flat series, form the basis for drive systems in applications where space is extremely limited. With their powerful rare-earth magnets, the motors deliver a continuous output of 1.5 W to 9 W and at the same time have only minimal inertia. In combination with the integrated gear-heads in extremely flat design, the motors provide a very compact drive system with increased output torque. Due to the electronic commutation of the drives, the service life is many times longer compared to mechanically commutated motors.

Series

1509 ... B	1515 ... B
2610 ... B	2622 ... B

Key Features

Motor diameter	15 ... 26 mm
Motor length	9 ... 22 mm
Nominal voltage	6 ... 12 V
Speed	up to 40.000 min ⁻¹
Torque	up to 100 mNm
Continuous output	up to 9 W

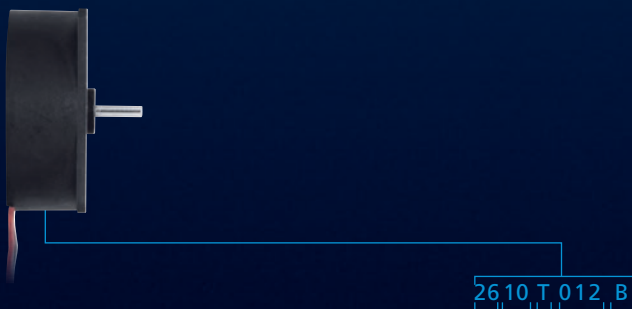

Product Code

26	Motor diameter [mm]
10	Motor length [mm]
T	Shaft type
012	Nominal voltage [V]
B	Product family

FAULHABER B-Flat

Advantages of this series at a glance

- Extremely flat design.
Lengths ranging from 9 mm to 22 mm
- 4-pole design
- Electronic commutation using
three digital Hall sensors
- Integrated spur gearheads
of minimal length with high
gear ratio are available
- Precise speed control

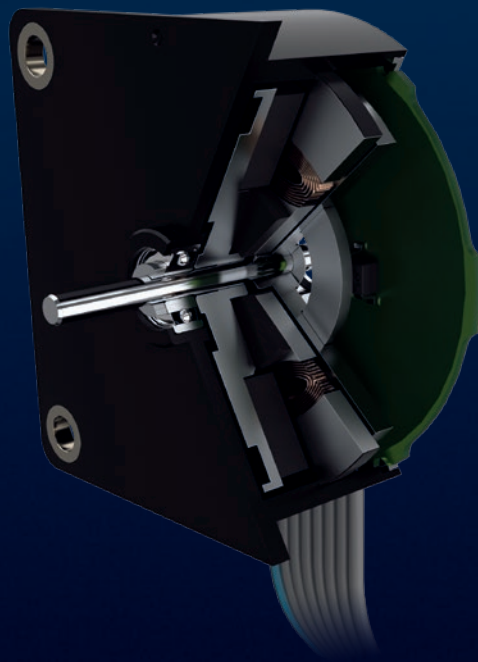

Brushless flat motors with External rotor technology

The external rotor motors of the BXT series set new standards: thanks to innovative winding technology and optimum design, the BXT motors deliver a torque of up to 134 mNm. The ratio of torque to weight and size is unmatched. The iron-core motors with 14 high-performance rare earth magnets on the rotor and 12 teeth on the stator are just 14 mm, 16 mm and 21 mm long, making them suitable for applications that require a short drive solution with high torque. Combined with optical and magnetic encoders, gearheads and controls, the result is a compact drive system.

Series

2214 ... BXT R	2214 ... BXT H
3216 ... BXT R	3216 ... BXT H
4221 ... BXT R	4221 ... BXT H

Key Features

Motor diameter	22 ... 42 mm
Motor length	14 ... 21 mm
Nominal voltage	6 ... 48 V
Speed	up to 10.000 min ⁻¹
Torque	up to 134 mNm
Continuous output	up to 100 W

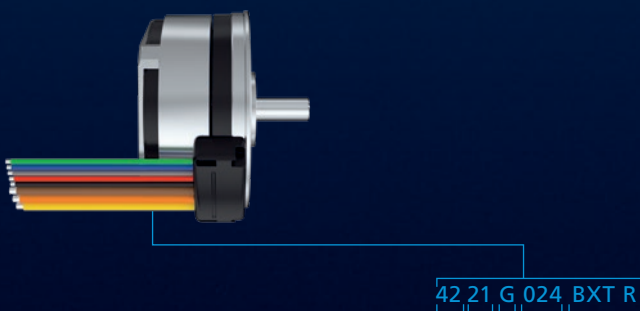

Product Code

42	Motor diameter [mm]
21	Motor length [mm]
G	Shaft type
024	Nominal voltage [V]
BXT	Product family
R	Open construction

FAULHABER BXT

Advantages of this series at a glance

- External rotor motors with very high torque
- Continuous output up to 100 W
- Outstanding ratio of torque to weight and size
- Flat design for space-critical applications. Length range of 14 to 21 mm.
- Matching optical and magnetic encoders, gearheads and controls available
- 14-pole construction

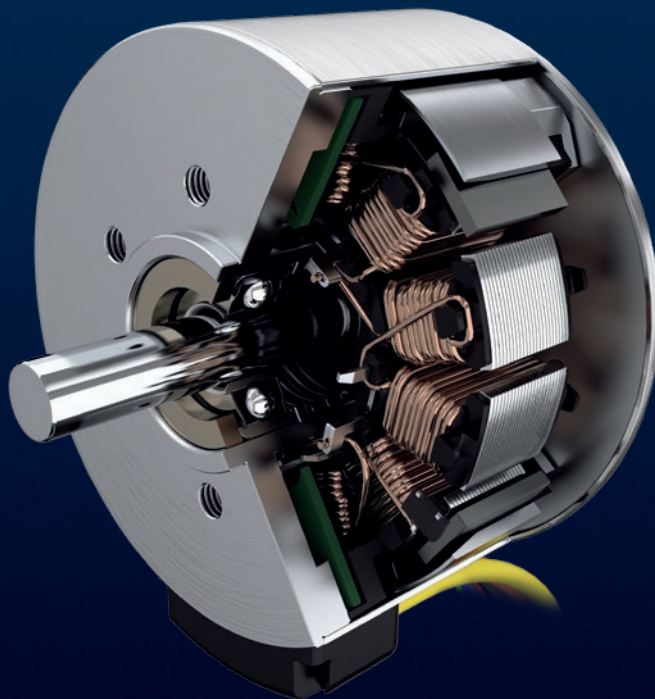

Motors with integrated Electronics



Speed Control Systems

Technical Information

Connection variants

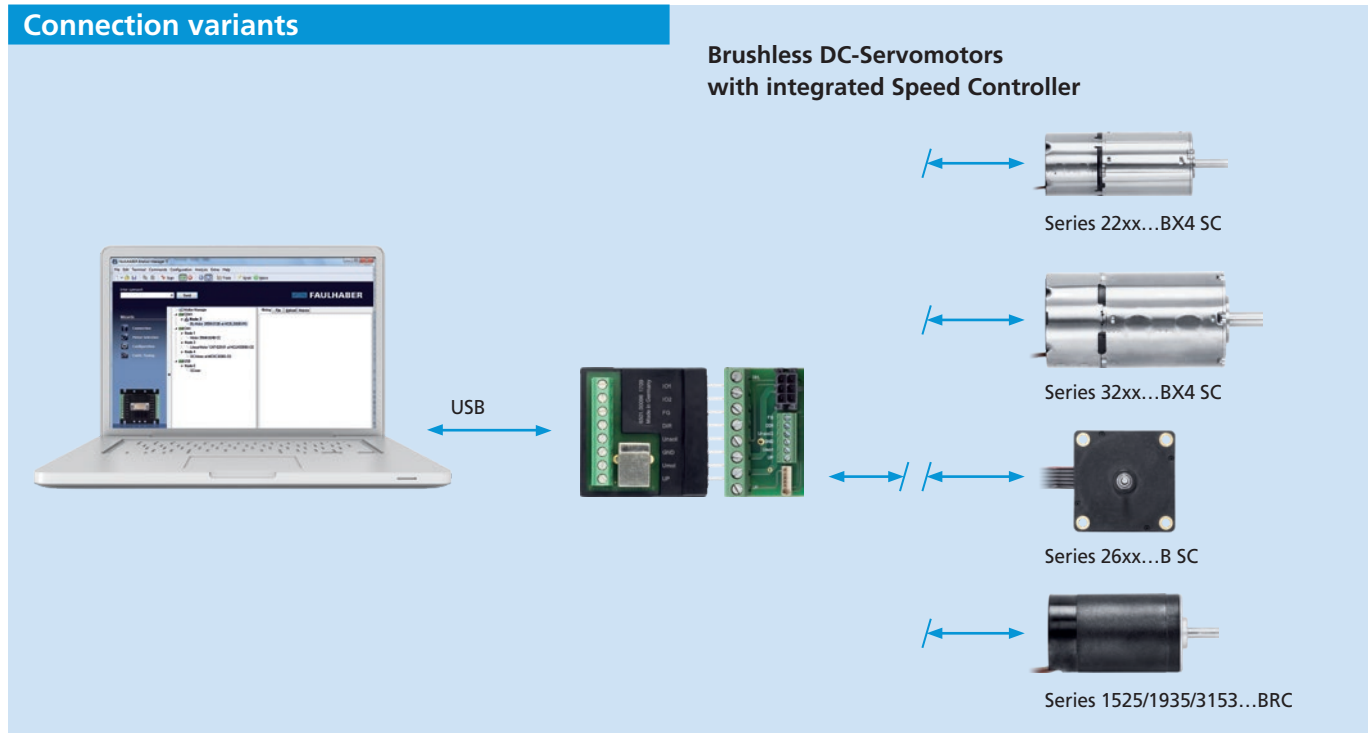

General Information

FAULHABER Speed Control Systems are highly dynamic drive systems with controlled speed. The drive electronics are already integrated and matched to the respective motor.

The compact integration of the Speed Controller as well as the flexible connection possibilities open a wide range of applications in areas such as laboratory technology and equipment manufacturing, automation technology, pick-and-place machines and machine tools, or pumps.

The integration of the control electronics in space-optimised add-on systems reduces space requirements and simplifies installation and start-up.

The integrated electronics facilitate speed control by means of a PI controller with external setpoint input. The direction of rotation can be changed via a separate switching input; the speed signal can be read out via the frequency output.

The motors can optionally be operated as a voltage controller or in fixed speed mode.

Speed Control Systems can be adapted to the application via the FAULHABER Motion Manager software. The type and scaling of the setpoint input, the operating mode and the control parameters can be adjusted. The USB programming adapter for Speed Controllers is used for configuration, and a contacting board is used for connecting the ribbon cables.

Interfaces – discrete I/O

- Analog input as setpoint input for setting the speed via PWM or analog voltage value
- Digital input as switching input for defining the direction of rotation of the motor
- Digital output, can be programmed either as frequency output or as error output

Note

Device manuals for installation and start-up, as well as the "FAULHABER Motion Manager" software, are available on request or on the Internet under www.faulhaber.com.

Speed Control Systems

Technical Information

Brushless DC-Servomotors with integrated Speed Controller 4 Pole Technology

3242 ... BX4 SC

Values at 22°C and nominal voltage		3242 G
Power supply electronic	U_p	
Power supply motor	U_{mot}	
Nominal voltage for motor	U_N	
No-load speed (at U_N)	n_0	
Peak torque (S2 operation for max. 3s/2s)	M	
Torque constant		
PWM switching frequency		

Notes on technical data sheet

The following data sheet values of the Speed Control Systems are measured or calculated at nominal voltage and at an ambient temperature of 22°C.

Power supply for electronics U_p [V DC]

Describes the range of the permissible supply voltage for the control electronics.

Power supply for motor U_{mot} [V DC]

Describes the range of the permissible supply voltage for the base motor integrated in the complete system.

Motor nominal voltage U_N [V]

The voltage applied between two winding phases. This is the voltage at which the data sheet parameters are measured or calculated. Depending on the required speed, a higher or lower voltage can be applied within the permissible range of the supply voltage.

No-load speed n_0 [min^{-1}]

Describes the motor speed when idling and in the steady-state condition at nominal voltage.

Peak torque $M_{max.}$ [mNm]

Specifies the torque that the drive can reach in S2 operation (cold start without additional cooling) at nominal voltage and nominal conditions under constant load for the time specified in the data sheet without exceeding the thermal limit. Unless otherwise defined, the value that applies for the peak torque is equal to two times the continuous torque.

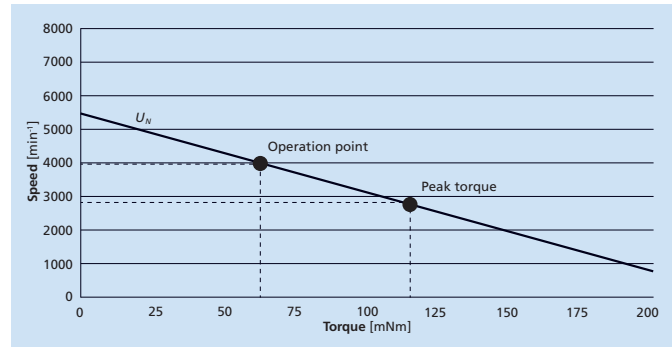

Example: 3242...BX4 SC

Torque constant k_m [mNm/A]

Constant that describes the ratio between motor torque and current input.

Starting torque [M_A]

Load torque with which the motor starts at room temperature and nominal voltage. This value can change depending on the magnet type and magnet temperature as well as the winding temperature.

PWM switching frequency f_{PWM} [kHz]

Pulse width modulation describes the change of the electrical voltage between two values. The motors integrated in the SCS have a low electrical time constant. To keep the losses associated with PWM low, a high switching frequency is necessary.

Electronics efficiency η [%]

Ratio between consumed and delivered power of the control electronics.

Standby current for the electronics I_{el} [A]

Describes the additional current consumption of the complete system that can be attributed to the integrated electronics.

Speed range [min^{-1}]

Describes the maximum no-load speed for continuous operation in the steady-state condition at elevated nominal voltage. Depending on the required speed, higher or lower voltage can be applied within the given system limits.

Mounting of the system on a plastic flange according to installation type IM B 5.

Shaft bearings

The bearings used for the brushless DC motors.

Shaft load, max. permissible [N]

Max. permissible shaft load of the output shaft with specified shaft diameter. The values for load and service life of motors with ball bearings are based on manufacturer specifications. This value is not applicable for a possibly available rear or second shaft end.

Shaft play [mm]

Clearance between the shaft and bearing including the additional bearing clearance in the case of ball bearings.

Operating temperature range [°C]

Shows the minimum and maximum operating temperature of the complete system under nominal conditions.

Housing material

Housing materials and, if necessary, surface treatment.

Mass [g]

The typical mass of the standard system may vary due to the different component variants.

Length dimensions without mechanical tolerance specifications:

Tolerances according to ISO 2768:

≤ 6 = ± 0.1 mm

≤ 30 = ± 0.2 mm

≤ 120 = ± 0.3 mm

The tolerances of non-specified values are available on request.

All mechanical dimensions of the motor shaft are measured with an axial shaft load in the direction of the motor.

Rated Values for Continuous Operation

The following values are measured at nominal voltage, an ambient temperature of 22°C and with mounting type IM B 5.

Mounting type IM B 5 defines the flange mounting of the drive without mounting feet with two bearing plates, free front shaft end and mounting flange close to the bearing.

Rated torque M_N [mNm]

Maximum continuous torque (S1 mode) at nominal voltage at which in the steady-state condition the temperature does not exceed the maximum permissible winding temperature and/or the operating temperature range of the motor. The motor is fastened to a metal flange here, which approximates the amount of cooling available from a typical mounting configuration of the motor. This value can be exceeded if the motor is operated intermittently, for example, in S2 mode and/or if more cooling is applied.

Rated current I_N [A]

Typical maximum continuous current in the steady-state condition which results from the rated torque in continuous operation. This value can be exceeded if the drive is operated intermittently, in start/stop mode, in the starting phase and/or if more cooling is used.

Rated speed n_N [min⁻¹]

Typical rated speed in the steady-state condition which is determined from the given rated torque.

This value takes into account the effects that motor losses have on the slope of the n/M characteristic curve.

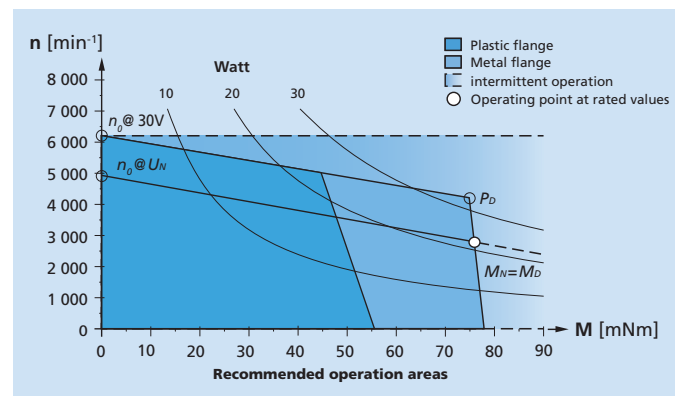

Example: Performance diagram for rated values with continuous operation.

Explanations on the Performance Diagram

The performance diagram shows the possible operating points of the servo-drives.

Operating points in the dark blue area are reached continually in the case of pure flange mounting (IM B5) on a plastic flange (approx. 100mm x 100mm x 10mm) and at an ambient temperature of 22°C.

Operating points in the light blue area up to P_D are reached continually in the case of pure flange mounting (IM B5) on an aluminium flange (approx. 100mm x 100mm x 10mm) and at an ambient temperature of 22°C.

The maximum achievable speed depends on the motor supply voltage. At nominal voltage, the maximum achievable operating points are those on the nominal voltage line through the no-load point and nominal point.

Speeds above the nominal voltage line are reached at an increased supply voltage.

In this case, the maximum voltage for the electronics or motor supply must never be exceeded.

The possible speed ranges are shown in dependence on the shaft torque.

Speed Control Systems

Technical Information

The sector shown dashed describes possible operating points in which the drive can be engaged in intermittent operation or with increased cooling.

Continuous torque M_D [mNm]

Describes the max. recommended continuous torque in the steady-state condition at nominal voltage and mounting on an aluminium flange. With Speed Control Systems, the continuous torque simultaneously corresponds to the rated torque.

Here, the speed is linear to the continuous torque. The continuous torque is independent of the continuous output power and can be exceeded if the motor is operated intermittently, for example, in S2 operation and/or if more cooling is applied.

Continuous output power P_D [W]

Describes the max. possible output power in continuous operation in steady-state condition with mounting on an aluminium flange. The value is independent of the continuous torque, responds linearly to the cooling factor and can be exceeded if the motor is operated intermittently, for example, in S2 operation and/or if more cooling is applied.

Nominal voltage curve U_N [V]

The nominal voltage curve describes the possible continuous operating points at U_N . In steady state, the starting point corresponds to the no-load speed n_0 of the drive. Operating points above this curve can be attained by an increase, operating points below by a reduction of the nominal voltage.

Note



Easy commissioning with the new Motion Manager 6.

Depending on the cooling factor, operating point and ambient temperature, it may be necessary to adjust the current limitation parameters using the operating software. See technical manual for details.

Speed Control Systems

Basic design

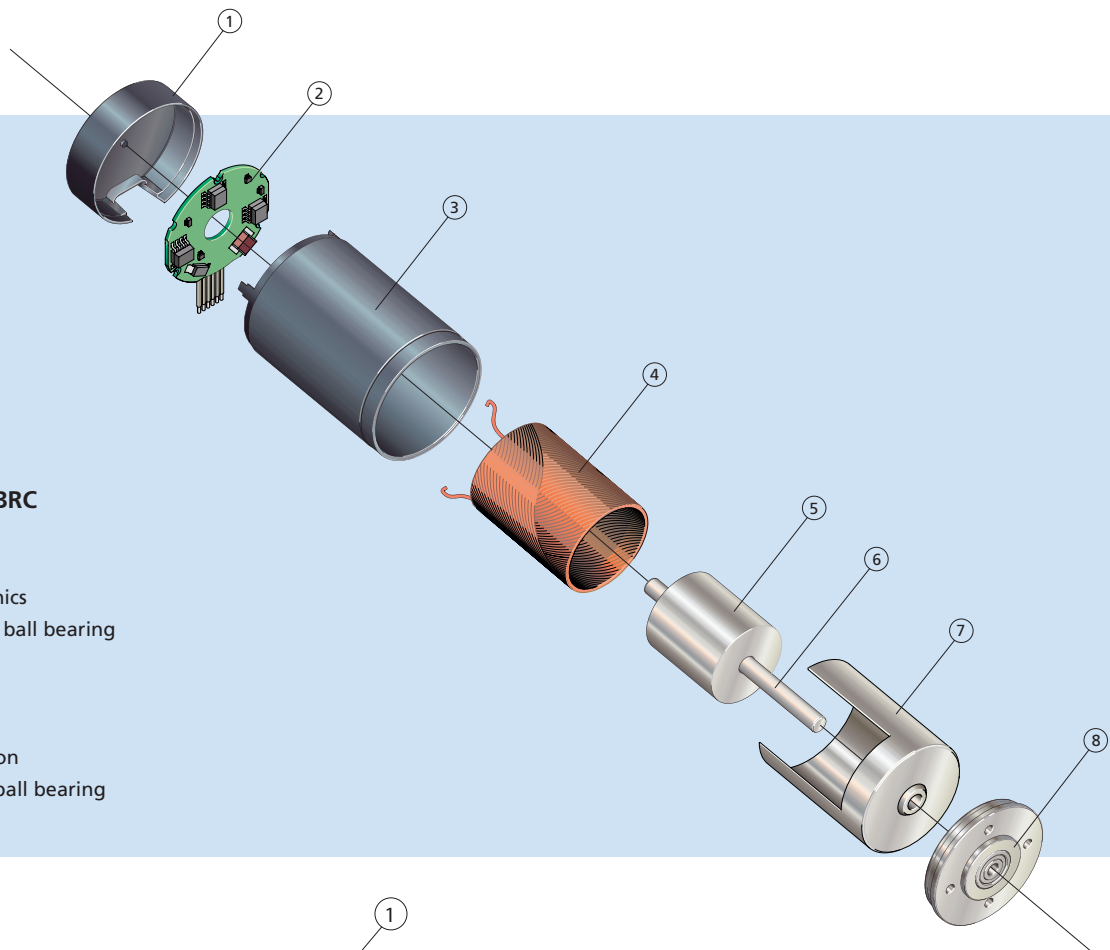

FAULHABER BRC

- ① Rear cover
- ② Drive Electronics
- ③ Housing with ball bearing
- ④ Winding
- ⑤ Magnet
- ⑥ Shaft
- ⑦ Rotor back-iron
- ⑧ Washer with ball bearing

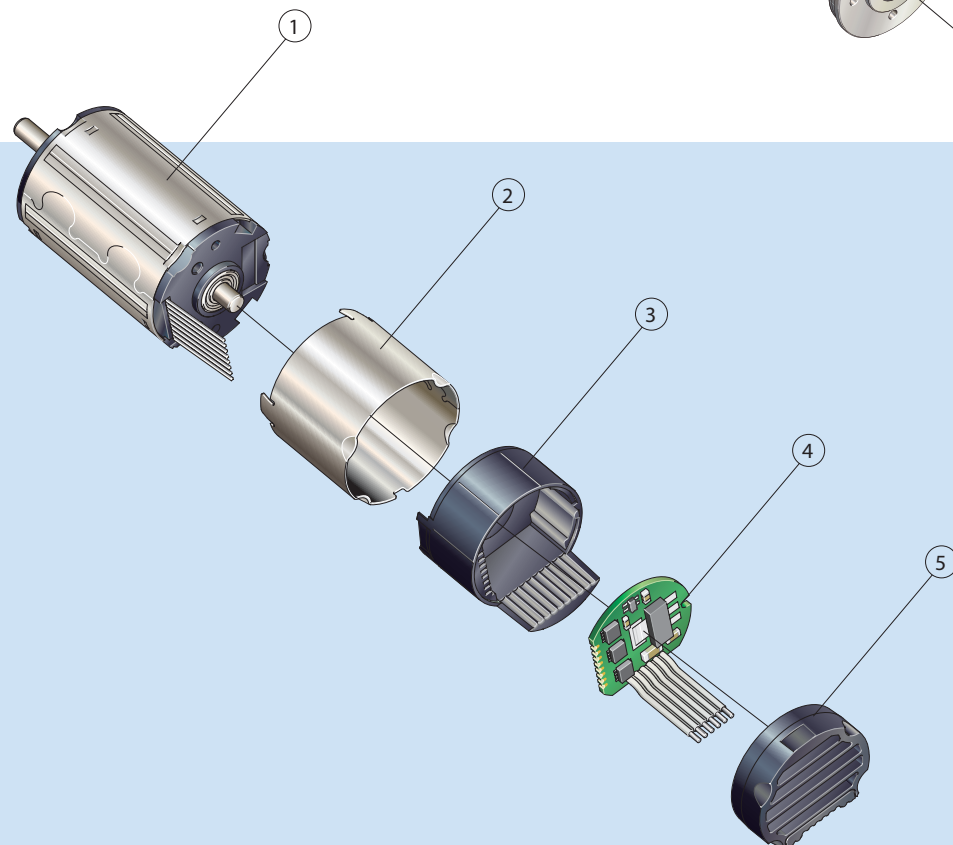

FAULHABER BX4 SC

- ① Motor
- ② Housing
- ③ Mounting flange
- ④ Electronics PCB
- ⑤ End cap

Speed Control Systems

Basic design

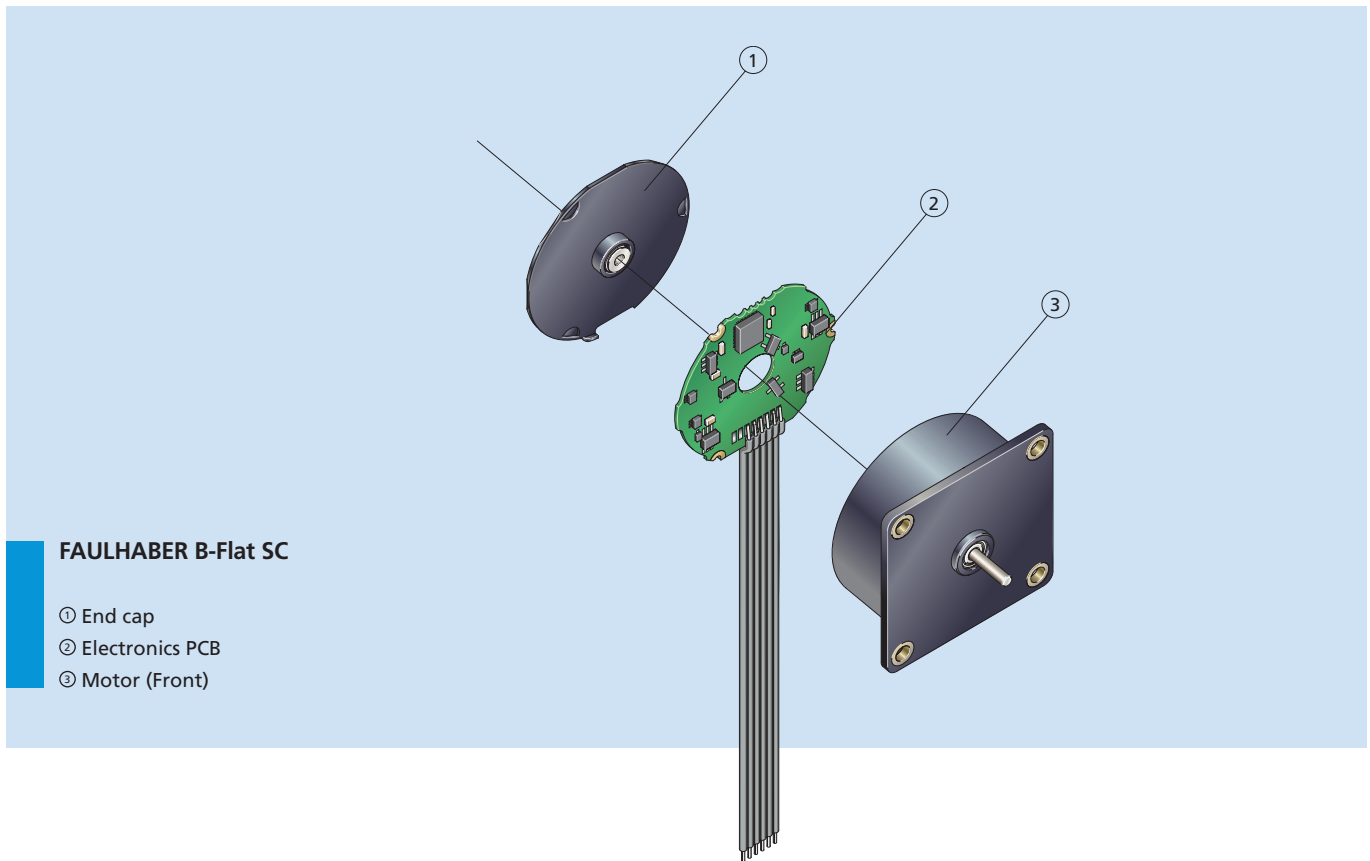

Notes



Brushless DC-Motors with integrated Speed Controller

The efficient motor series with continuously smooth running impresses with an extraordinarily long service life. In optimised continuous operation, the motors of the BRC family convince with their high-performance bearings and cogging-free running in the linear speed and torque range. The brushless motors with integrated speed controller operate with precise speed control.

This allows the operating point and the operating behaviour to be precisely controlled by means of corresponding software. Measuring 15 to 31 mm in diameter, these motors are suitable for installation in extremely confined spaces and – thanks to their robust design – also for applications with high loads. The motors can be operated reversibly in a clockwise or anti-clockwise direction, depending on the required control mode. The frequency output of these motors enables precise reproduction and determination of the speed of the motor.

Series

1525 ... BRC	1935 ... BRC
3153 ... BRC	

Key Features

Motor diameter	15 ... 31 mm
Motor length	25 ... 53 mm
Nominal voltage	6 ... 24 V
Speed	up to 25.000 min ⁻¹
Torque	up to 5,9 mNm
Continuous output	up to 17,5 W



Product Code

31	Motor diameter [mm]
53	Motor length [mm]
K	Shaft type
012	Nominal voltage [V]
BRC	Product family

FAULHABER BRC

Advantages of this series at a glance

- Programmable motor characteristics through integrated speed controller
- Outstanding reliability, long service life
- Dynamically balanced rotor, quiet running
- No cogging
- Wide, more linear speed/torque range
- Smooth running

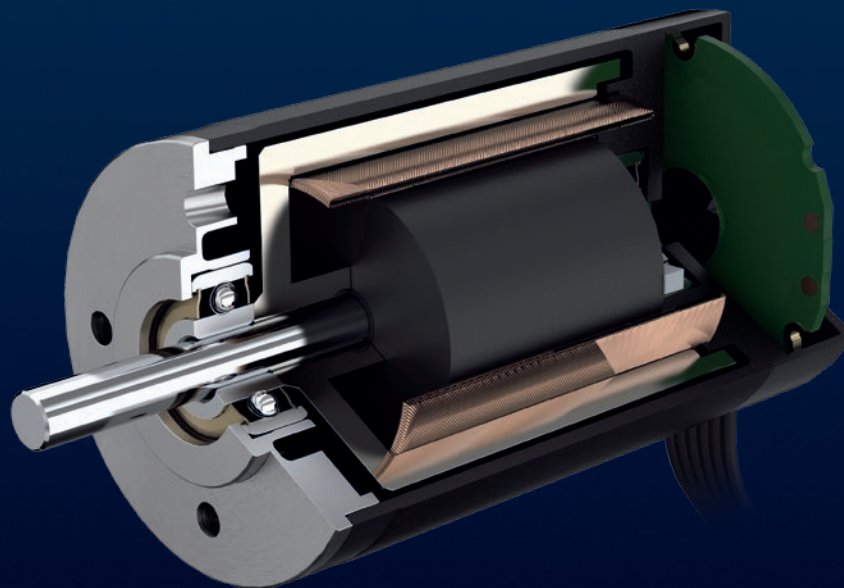

Brushless DC-Servomotors with integrated Speed Controller

The drives with integrated speed controller combine the advantages of brushless DC-Servomotors with diameter-compliant control electronics installed in the mounted motor unit measuring just 18mm in length.

Combinable with various precision gearheads, they can be used in a wide variety of market sectors such as laboratory technology, equipment manufacturing, automation technology or machine construction. The default factory preconfiguration in combination with the Motion Manager allows quick and easy commissioning of the system.

The selectable Hall sensor type (digital/analogue) ensures optimum coverage over a wide speed range. The integrated current limitation matched to the respective type protects the motor against overloading and therefore against potential destruction. The two-wire version SCDC allows brushed DC-Motors to be replaced easily in certain applications.

Series

2232 ... BX4 SC	2250 ... BX4S SC
2250 ... BX4 SC	3242 ... BX4 SC
3242 ... BX4 SCDC	3268 ... BX4 SC
3268 ... BX4 SCDC	

Key Features

Motor diameter	22 ... 32 mm
Motor length	49,6 ... 85,4 mm
Nominal voltage	12 ... 24 V
Speed	up to 14.000 min ⁻¹
Torque	up to 99 mNm
Continuous output	up to 53 W



Product Code

22	Motor diameter [mm]
32	Motor length [mm]
S	Shaft type
024	Nominal voltage [V]
BX4	Product family
SC	Integrated Speed Controller

FAULHABER BX4 SC

Advantages of this series at a glance

- High torque and speed rigidity thanks to 4-pole technology
- Speed control in tight installation spaces; thanks to optional analogue Hall sensors, also available in the low speed range from 50 min⁻¹
- Modular, diameter-compliant mounting concept with integrated current limitation
- Simple and convenient programming using the Motion Manager and programming adapter
- High reliability and long service life
- Dynamically balanced rotor, quiet running

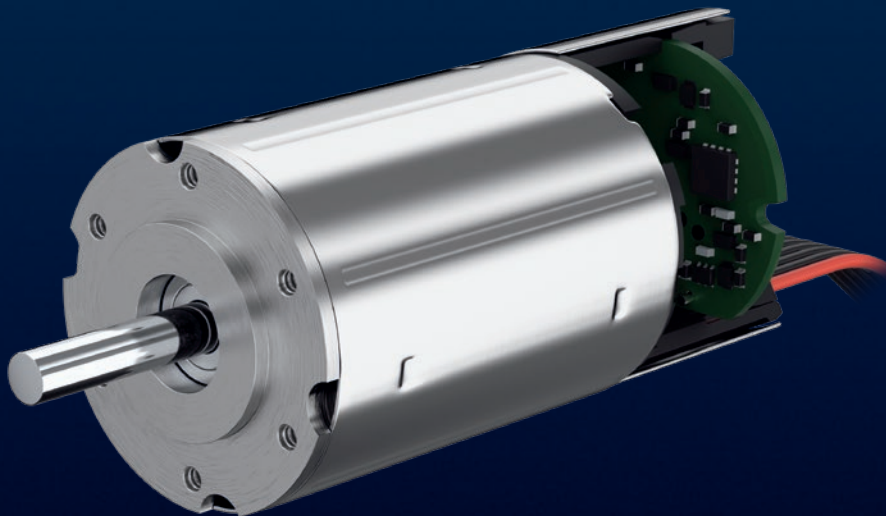

Brushless Flat DC-Micromotors and DC-Gearmotors with integrated Speed Controller

The brushless DC-Servomotors with integrated electronics are based on the motors of the B-Flat series. In the case of the B-Flat series, the four-pole brushless DC-Servomotors with their uniquely flat coil technology with three flat, self-supporting copper windings form the basis for drive systems in applications where installation space is extremely limited. As an integrated electronic actuation unit, a speed controller is already available for these motors. What makes this speed controller so special is that it is fully integrated on the motor circuit board and does not increase the length of the motor in any way. In combination with the extremely flat, integrated gearheads, these motors provide an extremely compact drive system with increased output torque.

Series

2610 ... B SC 2622 ... B SC

Key Features

Motor diameter	26 mm
Motor length	10,4 ... 22 mm
Nominal voltage	6 ... 12 V
Speed	up to 13.000 min ⁻¹
Torque	up to 100 mNm
Continuous output	up to 1,6 W

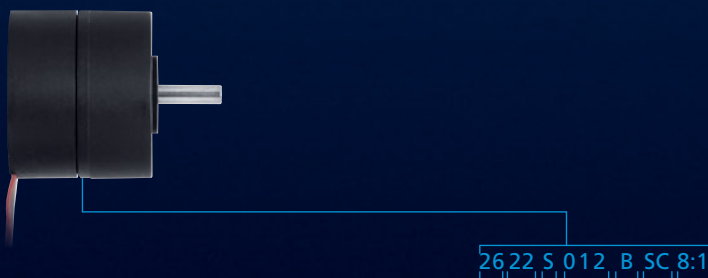

Product Code

26	Motor diameter [mm]
22	Motor length [mm]
S	Shaft type
012	Nominal voltage [V]
B	Product family
SC	Integrated Speed Controller
8:1	Gearhead reduction

FAULHABER B-Flat SC

Advantages of this series at a glance

- Extremely flat design. Lengths ranging from 10 mm to 22 mm with speed controller already integrated
- 4-pole design
- Easy to use
- Integrated spur gearheads of minimal length with high gear ratio are available
- Precise speed control

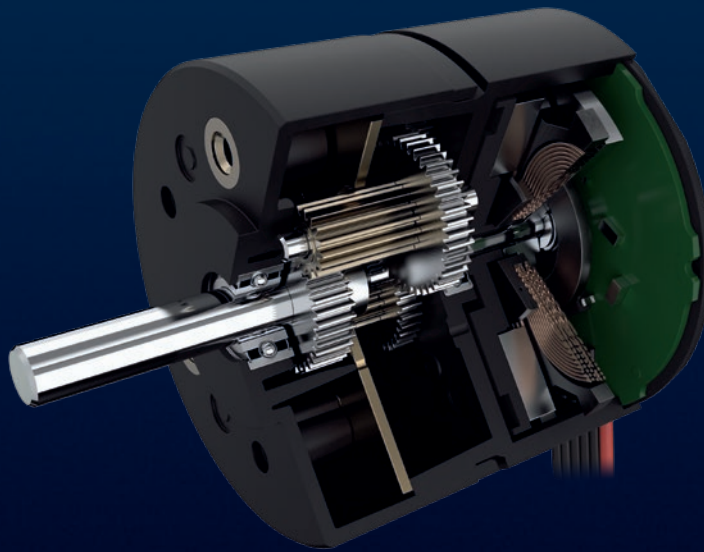

Motion Control Systems

Feature Comparison

General Information

The space-optimized FAULHABER Motion Control systems are available in various series. The different variants are suitable for a variety of market segments and the flexible connection possibilities open a wide range of applications in areas such as equipment manufacturing, pick-and-place machines and machine tools, robotics or special machinery construction. They can be put into operation easily and quickly via Motion Manager, which is available for download at no charge.

Generation V2.5

- Proven technology for BL motors in various sizes and performance classes
- Very simple configuration and start-up
- Numerous configuration options
- Successfully used in medical and laboratory technology, equipment manufacturing, automation, medical technology and aerospace

Generation V3.0

A new generation of integrated Motion Controllers for applications that go beyond the features and performance offered by the V2.5 series.

- More power
- Faster control
- New operating modes
- Flexible use of the I/Os for setpoints and actual values
- Additional I/Os and interfaces
- Sequential programs can be programmed in BASIC for simple, local automation in all interface technologies
- Expanded diagnostic functions
- Simple start-up via Motion Manager beginning with version 6.0

	Generation V2.5	Generation V3.0
Voltage ranges	<ul style="list-style-type: none"> ■ Motor: max. 30V ■ Electronics: max. 30V, optionally separated 	<ul style="list-style-type: none"> ■ Motor: max. 50V ■ Electronics: max. 50V, separated standard
PWM switching frequency	78 kHz	100 kHz
Peak torque	Up to 190 mNm	Up to 320 mNm
Motor types	22xx BX4 CxD 32xx BX4 Cx 3564 B Cx	32xx BX4 RS / CO / ET 3274 BP4 RS / CO / ET
Inputs/outputs	DigIn: max. 3 DigOut: max. 1 AnIn: 1 (not all I/Os available depending on wiring)	DigIn: 3 DigOut: 2 AnIn \pm 10V: 2 (standard)
Communication	<ul style="list-style-type: none"> ■ RS232 ■ CANopen 	<ul style="list-style-type: none"> ■ RS232 ■ EtherCAT ■ CANopen ■ USB
Controller	Position, speed, current limiting	Position, speed, current / torque
Operating modes	<ul style="list-style-type: none"> ■ Depending on the interface variant, position, speed and current control with setpoint input via the interface or analog (RS) 	<ul style="list-style-type: none"> ■ Profile Position mode (PP) and Profile Velocity mode (PV), taking into account profile settings ■ Cyclic Synchronous Position, speed or torque (CSP, CSV or CST) ■ Analog input for position, speed, torque or voltage (APC, AVC, ATC, volt)
Profile operation	Linear trapezoidal profiles in all operating modes	Linear or \sin^2 speed in PP and PV modes
Autonomous processes	Available in the versions with RS232 interface.	Up to eight sequential programs in all versions, with optional password protection
Protection class	n/a	IP 54 (optionally with shaft seal)

Motion Control Systems V2.5

Technical Information

Connection variants

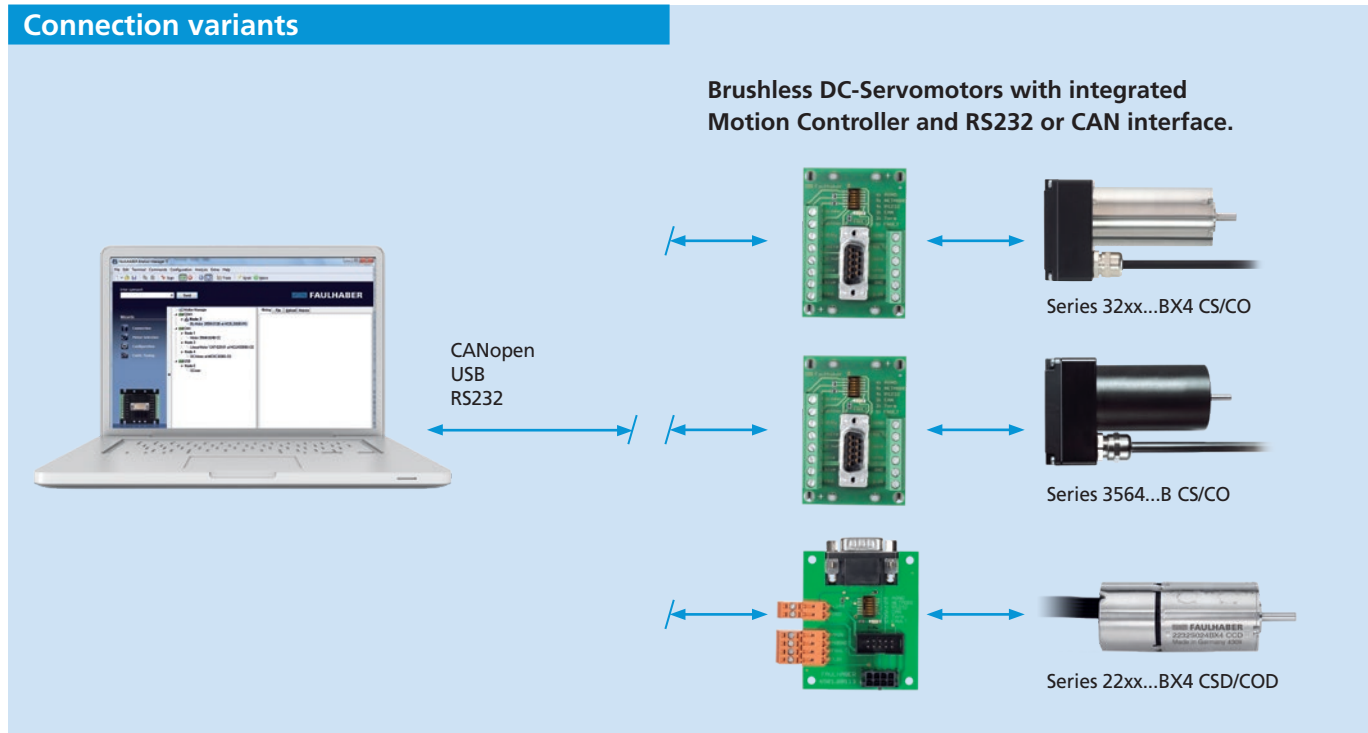

Features

FAULHABER Motion Control Systems of generation V2.5 are highly dynamic positioning systems. The drive electronics are already integrated and matched to the motor. The function of the Motion Control Systems is completely identical to the external MCBL 300x FAULHABER Motion Controllers of generation V2.5.

In addition to use as a servo drive with controlled position, the speed can also be controlled. Via an integrated current control, the torque is limited and the drive protected against overload.

Motion Control Systems of generation V2.5 are available with RS232 or with CAN interface and, as a result, can also be integrated in networks. In addition to operation on a PC, the systems can also be operated on all common industrial controls.

The integration of the motor and control electronics reduces space requirements and simplifies installation and start-up.

Benefits

- Compact construction
- Modular design, various performance ratings
- Minimal wiring required
- Parametrization via "FAULHABER Motion Manager" software
- Wide range of accessories
- Adapter for connection to USB interface
- Simple start-up

Product code



3268	motor series
G	shaft type
024	nominal voltage
BX4	electronic commutation brushless
CS	Serial interface RS232

3268 G 024 BX4 CS

Motion Control Systems V2.5

Configuration, networking, interfaces

Operating modes

Positioning operation

The drive moves to the preset target position and, in doing so, maintains the specified limits for speed and position. The dynamics of the control can be adapted to a wide range of loads. Limit switches can be evaluated directly. The position can be initialised via limit switches or a reference switch.

Speed control

The drive controls the the preset target speed via a PI speed controller without lasting deviation.

Current control

Protects the drive by limiting the motor current to the set peak current. By means of integrated thermal models, the current is limited to the continuous current if necessary.

Motion profiles

Acceleration and brake ramp as well as the maximum speed can be preset in speed and positioning operation.

Autonomous operation

In version RS, freely programmable processes can be stored in the Motion Controller. Operation is then also possible without RS232 interface.

Protective features

- Protection against ESD
- Overload protection for electronics and motor
- Self-protection from overheating
- Overvoltage protection in generator mode

Operating modes (CS)

- Position control
 - with setpoint input via the interface
 - with analog setpoint
 - gearing mode
 - stepper motor operation
- Speed control
 - with setpoint input via the interface
 - with analog setpoint
- Torque control
 - with setpoint input via the interface
 - with analog setpoint
- Operation as Servo Amplifier in voltage controller mode

Operating modes (CO)

- Profile Position mode (PP)
- Profile Velocity mode (PV)
- Homing mode

Options

Separate supply of power to the motor and electronic actuator is optional (important for safety-critical applications). Third Input is not available with this option. Depending on the drive, additional programming adapters and connection aids are available. The modes and parameters can be specially pre-configured on request.

Interfaces – discrete I/O

Setpoint input

Depending on the operating mode, setpoints can be input via the command interface, via an analog voltage value, a PWM signal or a quadrature signal.

Error output (Open Collector)

Configured as error output (factory setting). Also usable as digital input, free switch output, for speed control or signaling an achieved position.

Additional digital inputs

For evaluating reference switches.

Networking

FAULHABER Motion Control Systems of generation V2.5 are available in all two networking variants.

RS – systems with RS232 interface

Ideal for equipment manufacturing and for all applications in which the controller is also to be used without a higher level controller. Using Net mode, it is also possible to operate multiple RS controllers on an RS232 interface.

CO – CANopen acc. to CiA 402

The ideal variant for the operation of a FAULHABER Motion Controller on a PLC – directly via the CANopen interface or via a gateway on, e.g., Profibus/ProfiNET or on EtherCAT.

Interfaces – Bus Connection

Version with RS232

For coupling to a PC with a transfer rate of up to 115 kbaud. Multiple drives can be connected to a single controller using the RS232 interface. As regards the control computer, no special arrangements are necessary. The interface also offers the possibility of retrieving online operational data and values.

A comprehensive ASCII command set is available for programming and operation. This can be preset from the PC using the “FAULHABER Motion Manager” software or from another control computer.

Additionally, there is the possibility of creating complex processes from these commands and storing them on the drive. Once programmed as a speed or positioning controller via the analog input, as step motor or electronic gear unit, the drive can operate independently of the RS232 interface.

Version with CANopen CO

A controller variant with CANopen interface is available to allow optimal integration in a wide variety of different applications. CANopen is ideal for networking microdrives because the interface can also be integrated in small electronics modules. Its size and the efficient communication procedures mean that it is ideally suited for use in industrial automation.

The CO version provides the CiA 402 standard operating modes. All the parameters are directly stored in the object directory. Configuration can therefore be performed with the help of the FAULHABER Motion Manager or by applying available standardized configurations tools common to the automation market.

The CO version is particularly suitable for users who already use various CANopen devices or operate the Motion Controllers on a PLC. With dynamic PDO mapping it is possible to achieve highly efficient networking on the CAN.

Features CO

	CO
NMT with node guarding	•
Baud rate	1 Mbit max., LSS
EMCY object	•
SYNCH object	•
Server SDO	1 x
PDOs	4 x Rx 4 x Tx each with dynamic mapping
PDO ID	adjustable
Configuration	Motion Manager from V5
Trace	Any PDO
Standard operating modes	•
- Profile Position Mode - Profile Velocity Mode - Homing	

The model supports the CANopen communication profile acc. to CiA 301 V4.02. Transfer rate and node number are set via the network in accordance with the LSS protocol as defined in CiA 305 V1.11.

For this purpose, we recommend using the latest version of the FAULHABER Motion Manager.

Note

Device manuals for installation and commissioning, communication and function manuals as well as the “FAULHABER Motion Manager” software are available on request or on the Internet under www.faulhaber.com.

Motion Control Systems V2.5

Technical Information

General Information

System description

The drive systems integrate a brushless DC servomotor, a high-resolution encoder and a Motion Controller in a compact, complete drive unit.

Due to the fact that motor commutation is achieved electronically and not mechanically, the service life of a FAULHABER Motion Control Systems depends mainly on the service life of the motor bearings.

FAULHABER uses high-precision, preloaded ball bearings in all of its systems with integrated Motion Controller. Factors affecting the life of the motor bearings include the static and dynamic axial and radial bearing loads, the ambient thermal conditions, the speed, vibrational and shock loads, and the precision of the shaft coupling to the given application.

For highly dynamic servo applications requiring very high torque in the most compact dimensions, the integrated FAULHABER BX4 Series 4-pole, DC-Servomotors are ideal. Their robust design with very few parts and no glued components means that they are extremely durable and well suited for harsh ambient conditions such as extreme temperatures and high vibration and shock loads.

Thanks to their robust construction and their compact design, the FAULHABER Motion Control Systems of the V2.5 generation are perfectly suited for use in automation applications.

Modifications and accessories

FAULHABER specialises in the adaptation of its standard products for customer-specific applications. The following standard options and accessory parts are available for FAULHABER Motion Control Systems:

- Configurable shaft lengths
- Modified shaft dimensions and pinion configurations such as flats, gears, pulleys and eccenters
- Modifications for applications with higher speeds and/or higher loads
- Customized special configuration and firmware
- Separate voltage supply for motor and electronics
- Configuration and connection adapter

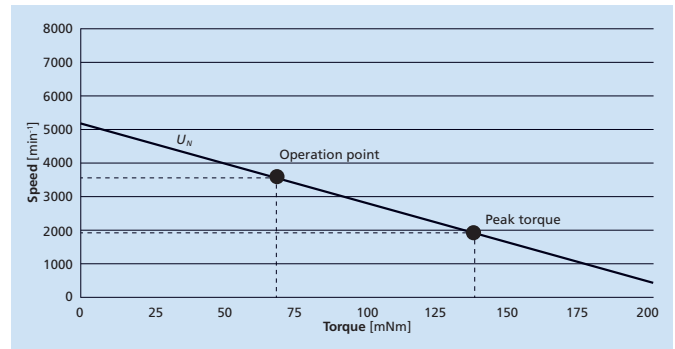
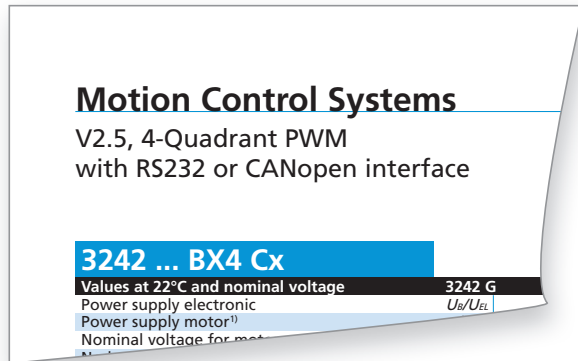

Example: 3242...BX4 Cx

Explanatory Notes for Data Sheets

The following data sheet values of the Motion Control Systems are measured or calculated at nominal voltage and at an ambient temperature of 22°C.

In their standard version, MCSs of generation V2.5 do not have separate supply inputs for motor and electronics, but can optionally be equipped with these inputs (via 3rd input).

Power supply for electronics U_B / U_{EL} [V DC]

Describes the range of the permissible supply voltage for the integrated control electronics.

Power supply for motor $-- / U_B$ [V DC]

Describes the range of the permissible supply voltage for the base motor integrated in the complete system.

Motor nominal voltage U_N [V]

The voltage applied between two winding phases. This is the voltage at which the data sheet parameters are measured or calculated. Depending on the required speed, a higher or lower voltage can be applied within the permissible range of the supply voltage.

No-load speed n_0 [min^{-1}]

Describes the motor speed when idling and in the steady-state condition at nominal voltage and sinus commutation.

Peak torque M_{max} [mNm]

Specifies the torque that the drive can reach in S2 operation (cold start without additional cooling) at nominal voltage and nominal conditions under constant load for the time specified in the data sheet without exceeding the thermal limit. Unless otherwise defined, the value that applies for the peak torque is equal to two times the continuous torque.

Torque constant k_m [mNm/A]

Constant that describes the ratio between motor torque and current input.

PWM switching frequency f_{PWM} [kHz]

Pulse width modulation describes the change of the electrical voltage between two values. The motors integrated in the MCS have a low electrical time constant. To keep the losses associated with PWM low, a high switching frequency is necessary.

Electronics efficiency η [%]

Ratio between consumed and delivered power of the control electronics.

Standby current for the electronics I_{el} [A]

Describes the additional current consumption of the complete system that can be attributed to the integrated electronics.

Speed range [min^{-1}]

Describes the maximum no-load speed for continuous operation in the steady-state condition at elevated nominal voltage (30 V). Depending on the required speed, higher or lower voltage can be applied within the given system limits.

Mounting of the system on a plastic flange according to installation type IM B 5.

Shaft bearings

The bearings used for the brushless DC motors.

Shaft load, max. permissible [N]

Max. permissible shaft load of the output shaft with specified shaft diameter. The values for load and service life of motors with ball bearings are based on manufacturer specifications. This value is not applicable for a possibly available rear or second shaft end.

Motion Control Systems V2.5

Technical Information

Shaft play [mm]

Clearance between the shaft and bearing including the additional bearing clearance in the case of ball bearings.

Operating temperature range [°C]

Shows the minimum and maximum operating temperature of the complete system under nominal conditions.

Housing material

Housing materials and, if necessary, surface treatment.

Mass [g]

The typical mass of the standard system may vary within the individual interface variants due to the different component variants.

Length dimensions without mechanical tolerance specifications:

Tolerances according to ISO 2768:

≤ 6 = ± 0.1 mm

≤ 30 = ± 0.2 mm

≤ 120 = ± 0.3 mm

The tolerances of non-specified values are available on request.

All mechanical dimensions of the motor shaft are measured with an axial shaft load in the direction of the motor.

Rated Values for Continuous Operation

The following values are measured at nominal voltage, an ambient temperature of 22°C and with mounting type IM B 5.

Mounting type IM B 5 defines the flange mounting of the drive without mounting feet with two bearing plates, free front shaft end and mounting flange close to the bearing.

Rated torque M_N [mNm]

Maximum continuous torque (S1 mode) at nominal voltage at which in the steady-state condition the temperature does not exceed the maximum permissible winding temperature and/or the operating temperature range of the motor. The motor is fastened to a metal flange here, which approximates the amount of cooling available from a typical mounting configuration of the motor. This value can be exceeded if the motor is operated intermittently, for example, in S2 mode and/or if more cooling is applied.

Rated current I_N [A]

Typical maximum continuous current in the steady-state condition which results from the rated torque in continuous operation. This value can be exceeded if the drive is operated intermittently, in start/stop mode, in the starting phase and/or if more cooling is used.

Rated speed n_N [min⁻¹]

Typical rated speed in the steady-state condition which is determined from the given rated torque.

This value takes into account the effects that motor losses have on the slope of the n/M characteristic curve.

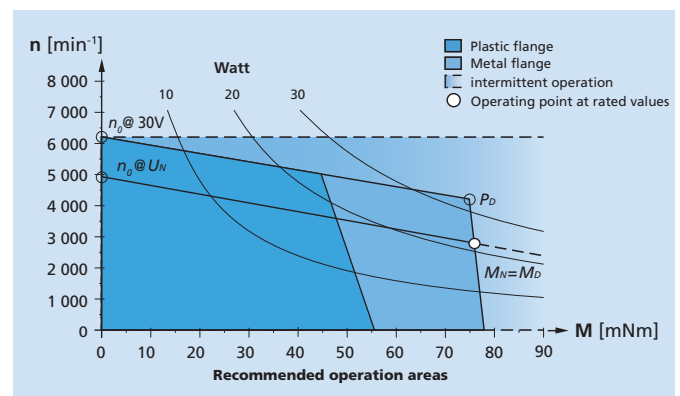

Example: Performance diagram for rated values with continuous operation.

Explanations on the Performance Diagram

The possible speed ranges are shown in dependence on the shaft torque.

The performance diagram shows the possible operating points of the servo-drives.

Operating points in the dark blue area are reached continually in the case of pure flange mounting (IM B5) on a plastic flange (approx. 100mm x 100mm x 10mm) and at an ambient temperature of 22°C.

Operating points in the light blue area up to P_D are reached continually in the case of pure flange mounting (IM B5) on an aluminium flange (approx. 100mm x 100mm x 10mm) and at an ambient temperature of 22°C.

The maximum achievable speed depends on the motor supply voltage. At nominal voltage, the maximum achievable operating points are those on the nominal voltage line through the no-load point and nominal point.

Speeds above the nominal voltage line are reached at an increased supply voltage.

In this case, the maximum voltage for the electronics or motor supply must never be exceeded.

The sector shown dashed describes possible operating points in which the drive can be engaged in intermittent operation or with increased cooling.

Continuous torque M_D [mNm]

Describes the max. recommended continuous torque in the steady-state condition at nominal voltage and mounting on an aluminium flange. With Motion Control Systems, the continuous torque simultaneously corresponds to the rated torque.

Here, the speed is linear to the continuous torque. The continuous torque is independent of the continuous output power and can be exceeded if the motor is operated intermittently, for example, in S2 operation and/or if more cooling is applied.

Continuous output power P_D [W]

Describes the max. possible output power in continuous operation in steady-state condition with mounting on an aluminium flange. The value is independent of the continuous torque, responds linearly to the cooling factor and can be exceeded if the motor is operated intermittently, for example, in S2 operation and/or if more cooling is applied.

Nominal voltage curve U_N [V]

The nominal voltage curve describes the possible continuous operating points at U_N . In steady state, the starting point corresponds to the no-load speed n_0 of the drive. Operating points above this curve can be attained by an increase, operating points below by a reduction of the nominal voltage.



Easy commissioning with the new Motion Manager 6.

Depending on the cooling factor, operating point and ambient temperature, it may be necessary to adjust the current limitation parameters using the operating software. See technical manual for details.

Motion Control Systems V2.5

Basic design

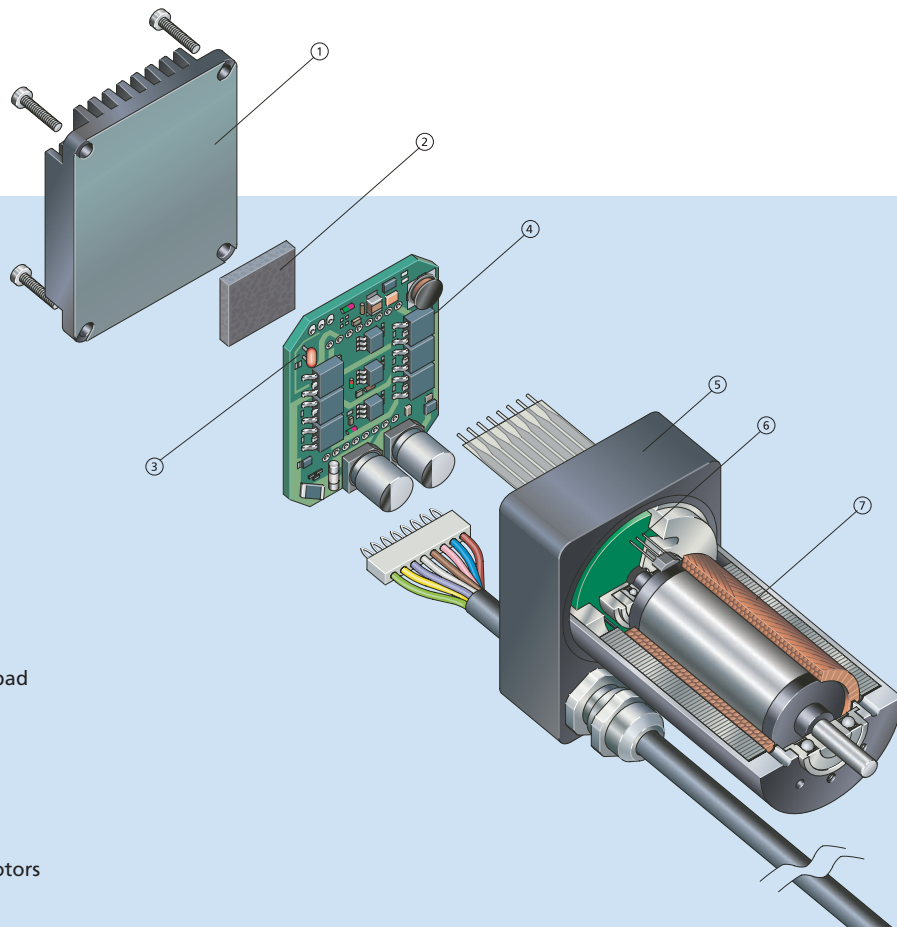

FAULHABER B Cx

- ① Heat sink/cover
- ② Thermal conduction pad
- ③ Thermal protection
- ④ Motion Controller with power stage
- ⑤ Housing
- ⑥ Analog Hall sensors
- ⑦ Brushless DC-Servomotors

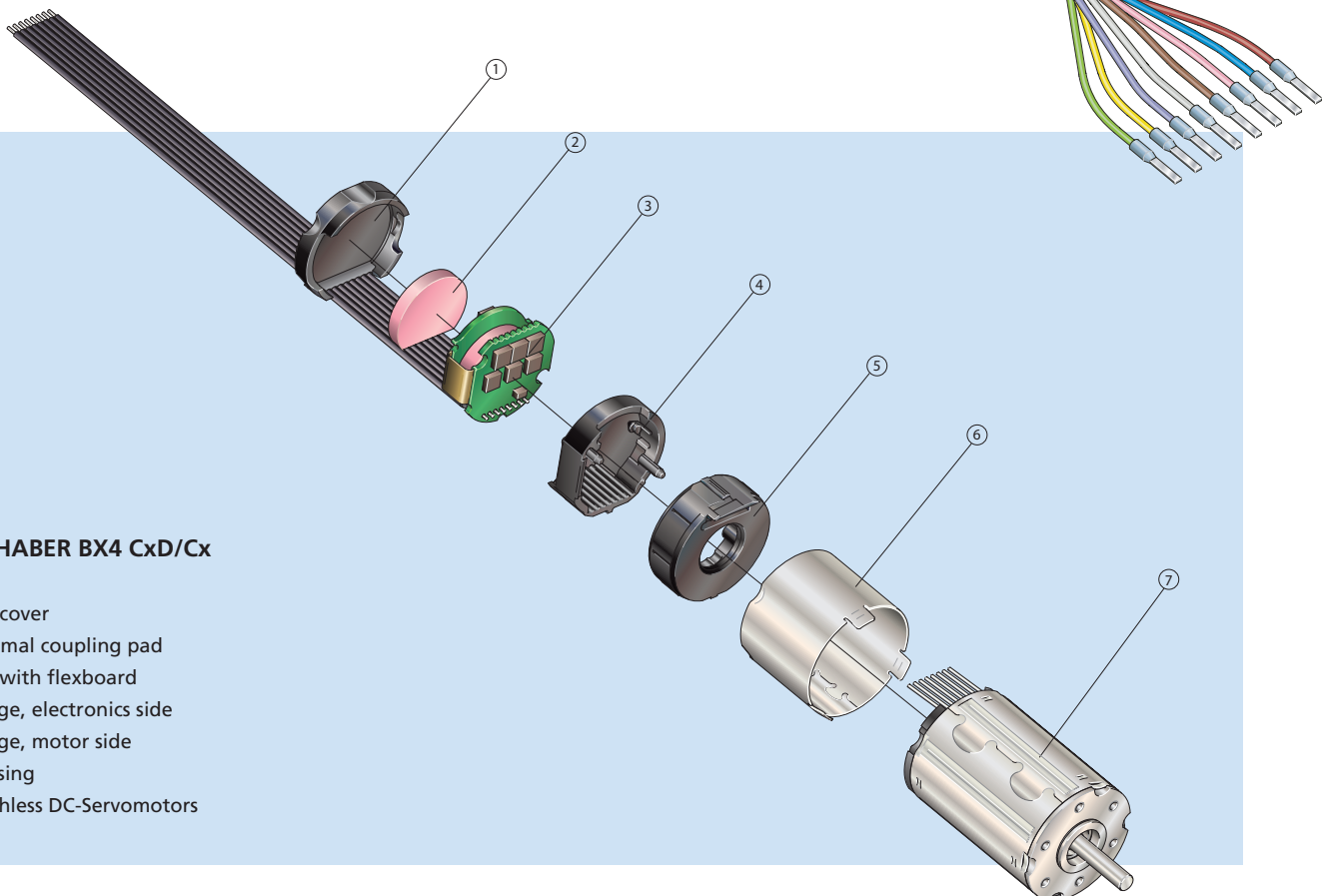

FAULHABER BX4 CxD/Cx

- ① End cover
- ② Thermal coupling pad
- ③ PCB with flexboard
- ④ Flange, electronics side
- ⑤ Flange, motor side
- ⑥ Housing
- ⑦ Brushless DC-Servomotors

Motion Control Systems V3.0

Technical Information



Features

FAULHABER Motion Control systems of generation V3.0 are highly dynamic positioning systems in three motor designs for use in combination with matched gearheads and ball screws from the FAULHABER product portfolio. The motor parameters are preconfigured ex works. Adaptation to the path is performed during commissioning using the FAULHABER Motion Manager from version 6.0.

In addition to use as a servo drive with controlled position, the speed or current can also be controlled. The actual values for speed and position are ascertained via the integrated encoders. Limit switches and reference switches can be directly connected.

The control setpoints can be preset via the communication interface, via the analogue input or a PWM input or can come from internally stored sequential programs.

Supported as communication interfaces are – depending on the device – RS232 or CANopen and optionally EtherCAT. All functions of the drive are available here without limitation via all interfaces.

FAULHABER Motion Control Systems of generation V3.0 are available in three motor variants and are, thus, perfectly scalable:

- MCS 3242 ... BX4
- MCS 3268 ... BX4
- MCS 3274 ... BP4

The possible applications are diverse: from laboratory automation to industrial equipment manufacturing, automation technology and robotics to aerospace.

The electrical connection of the systems is established via M12 plugs and extension cables. The flange profile is identical for all sizes.

Benefits

- Perfectly scalable thanks to various sizes
- Very dynamic control
- Various setpoint interfaces
- Stand-alone operation possible in all variants
- Connection via standard M12 plugs
- Fast feedback with status LEDs
- Commissioning with the free FAULHABER Motion Manager from version 6.0
- Configuration via programming adapter

Product code



MCS	Motion Control System
3268	Motor series
G	Type of drive
024	Nominal voltage - motor
BX4	Brushless electronic commutation
ET	EtherCAT interface

MCS_3268_G_024_BX4_ET

Motion Control Systems V3.0

Technical Information

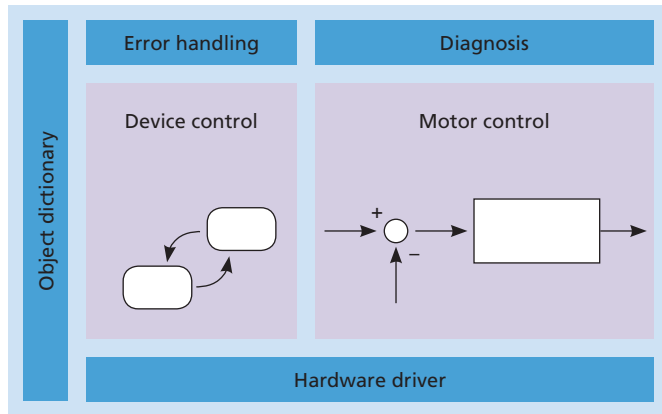

Operating modes

Motor control

Current, speed and position of the drive can be controlled via the controller cascade. By means of the optional pilot paths, even the fastest movements can be reliably controlled in a reproducible manner. Adjustable filters enable adaptation to a wide range of encoders and loads.

Motion profiles

Acceleration and brake ramp as well as the maximum speed can be preset in speed and positioning operation in the Profile Position Mode (PP) and Profile Velocity Mode (PV) operating modes.

Autonomous operation

Up to eight sequential programs written in BASIC can be stored and executed directly on the controller. One of these can be configured from the autostart application. Access protection can be activated.

Protection and diagnostic functions

FAULHABER Motion Control systems of generation V3.0 protect motors and electronics against overload by means of thermal models. The supply voltage is monitored and can also be used in regenerative operation. External devices are thereby protected against overvoltage during dynamic operation.

Profile Position Mode (PP) / Profile Velocity Mode (PV)

For applications in which only the target of the movement is specified for the controller. The acceleration and brake ramp as well as a possible maximum speed are taken into account via the integrated profile generator. Profile-based movements are, thus, suited for a combination with standard networks, such as RS232 or CANopen.

Cyclic Synchronous Position (CSP) / Cyclic Synchronous Velocity (CSV) / Cyclic Synchronous Torque (CST)

For applications in which a higher-level controller performs the path planning, even synchronised for multiple axes. The setpoints for position, speed and current are constantly updated. Typical update rates are in the range of a few milliseconds. Cyclic modes are, thus, primarily suited for combination with EtherCAT. CANopen can also be used.

Analogue Position Control (APC) / Analogue Velocity Control (AVC) / Analogue Torque Control (ATC)

For applications in which the setpoints of the control are specified as an analogue value or, e.g., via a directly connected reference encoder. These operating modes are therefore particularly well suited for stand-alone operation without higher-level master.

Voltage controller (voltage mode)

In the voltage controller, only a current limiting controller is used. All control loops are closed by a higher-level system. The setpoint can be set via the communication system or via an analogue input.

Interfaces – discrete I/O

Three digital inputs for connecting limit and reference switches or for connecting a reference encoder. The logic levels are switchable.

Two analogue inputs ($\pm 10V$) are available that can be freely used as setpoint or actual value.

Two digital outputs are available that can be freely used as error output, for direct actuation of a holding brake or as flexible diagnosis output.

Options

All controllers can optionally be equipped with an EtherCAT interface.

For highly dynamic applications, the use of a braking chopper can help to dissipate recovered energy.

Networking

RS – systems with RS232 interface

Ideal for device construction and for all applications in which the Motion Controller is to be operated on an embedded controller. Using Net mode, it is also possible to operate multiple RS controllers on an RS232 interface. The transmission rate can lie between 9600 baud and 115 kbaud.

CO – CANopen acc. to CiA 402

The ideal variant for the operation of a FAULHABER Motion Controller on a PLC – directly via the CANopen interface or via a gateway on, e.g., Profibus/ProfiNET or on EtherCAT. Dynamic PDO mapping as well as node guarding or heartbeat are supported. Refresh rates for setpoint and actual values are typically from 10 ms here.

ET – EtherCAT

Motion Controller with direct EtherCAT interface. The controllers are addressed via CoE via the CiA 402 servo drive profile. Ideal in combination with a high-performance industrial controller that also performs path planning and interpolation of the movement for multiple axes. Refresh rates for setpoint and actual values from 0.5 ms are supported.

All described operating modes and functions are available independent of the used communication interface.

Note

Device manuals for installation and commissioning, communication and function manuals as well as the “FAULHABER Motion Manager” software are available on request or on the Internet under www.faulhaber.com.

General Information

System description

The drive systems integrate a brushless DC servomotor, a high-resolution encoder and a Motion Controller in a compact, complete drive unit.

Due to the fact that motor commutation is achieved electronically and not mechanically, the lifetime of a FAULHABER Motion Control System depends mainly on the lifetime of the motor bearings.

FAULHABER uses high-precision, preloaded ball bearings in all of its systems with integrated Motion Controller. Factors affecting the life of the motor bearings include the static and dynamic axial and radial bearing loads, the ambient thermal conditions, the speed, vibrational and shock loads, and the precision of the shaft coupling to the given application.

For highly dynamic servo applications requiring very high torque in the most compact dimensions, the integrated 4-pole DC-Servomotors, FAULHABER BX4 / BP4 series are ideal. Their robust design with very few parts and no glued components means that they are extremely durable and well suited for harsh ambient conditions such as extreme temperatures and high vibration and shock loads.

Thanks to their robust construction, their compact design and the connection concept with industrial-grade standard cables, the new FAULHABER Motion Control Systems are perfectly suited for use in automation applications.

Modifications and accessories

FAULHABER specialises in the adaptation of its standard products for customer-specific applications. The following standard options and accessory parts are available for FAULHABER Motion Control Systems:

- Industrial-grade connection and interface cables with plugs
- Configurable shaft lengths
- Modified shaft dimensions and pinion configurations such as flats, gears, pulleys and eccenters
- Modifications for applications with higher speeds and/or higher loads
- Adaptation of the protection classification via shaft seals
- Connection and configuration adapter
- Customized special configuration and firmware

Motion Control Systems V3.0

Technical Information

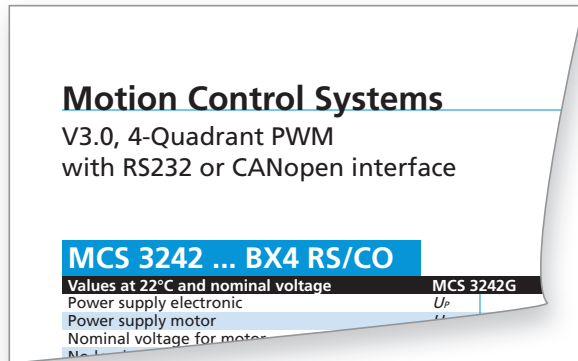

Explanatory Notes for Data Sheets

The following data sheet values of the Motion Control Systems are measured or calculated at nominal voltage and at an ambient temperature of 22°C.

Motion Control Systems generally feature separate supply inputs for motor and electronics with the same ground connection; if necessary, these inputs can also be used as a common supply.

Power supply for electronics U_e [V DC]

Describes the range of the permissible supply voltage for the integrated control electronics.

Power supply for motor U_{mot} [V DC]

Describes the range of the permissible supply voltage for the base motor integrated in the complete system.

Nominal voltage U_N [V]

The voltage applied between two winding phases by means of block commutation. This is the voltage at which the data sheet parameters are measured or calculated. Depending on the required speed, a higher or lower voltage can be applied within the permissible range of the supply voltage.

No-load speed n_0 [min^{-1}]

Describes the motor speed when idling and in the steady-state condition at nominal voltage and sinus commutation.

Peak torque M_{max} [mNm]

Specifies the torque that the drive can reach in S2 operation (cold start without additional cooling) at nominal voltage and nominal conditions under constant load for the time specified in the data sheet without exceeding the thermal limit. Unless otherwise defined, the value that applies for the peak torque is twice the continuous torque.

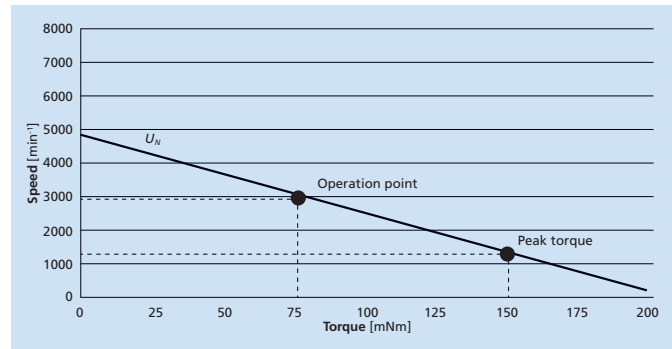

Example: MCS 3242...BX4

Torque constant k_m [mNm/A]

Constant that describes the ratio between motor torque and current input.

PWM switching frequency f_{PWM} [kHz]

Pulse width modulation describes the change of the electrical voltage between two values. The motors integrated in the MCS have a low electrical time constant. To keep the losses associated with PWM low, a high switching frequency is necessary.

Electronics efficiency η [%]

Ratio between consumed and delivered power of the control electronics.

Standby current for the electronics I_{el} [A]

Describes the additional current consumption of the complete system that can be attributed to the integrated electronics.

Shaft bearings

The bearings used for the brushless DC motors.

Shaft load, max. permissible [N]

Max. permissible shaft load of the output shaft with specified shaft diameter. The values for load and lifetime of motors with ball bearings are based on manufacturer specifications. This value is not applicable for a possibly available rear or second shaft end.

Shaft play [mm]

Play between the shaft and bearing including the additional bearing clearance for ball bearings.

Operating temperature range [°C]

Shows the minimum and maximum operating temperature of the complete system under nominal conditions.

Speed range [min⁻¹]

Describes the maximum no-load speed for continuous operation in the steady-state condition at elevated nominal voltage (30 V). Depending on the required speed, higher or lower voltage can be applied within the given system limits.

Mounting of the system on a plastic flange according to assembly method IM B 5.

Housing material

Housing materials and, if necessary, surface treatment.

Protection classification

Defines the level of protection of the housing against contact, foreign bodies and water. The codes that follow designation IP indicate the level of protection a housing offers against contact or foreign bodies (first digit) and humidity or water (second digit).

Maintenance measures are to be performed in defined time intervals due to additional protective measures such as shaft seals > see device manual for details.

Mass [g]

The typical mass of the standard system may vary within the individual interface variants due to the different component variants.

Length dimensions without mechanical tolerance specifications:

Tolerances according to ISO 2768:

≤ 6 = ± 0.1 mm

≤ 30 = ± 0.2 mm

≤ 120 = ± 0.3 mm

The tolerances of non-specified values are available on request.

All mechanical dimensions of the motor shaft are measured with an axial shaft load in the direction of the motor.

Rated Values for Continuous Operation

The following values are measured at nominal voltage, an ambient temperature of 22°C and with assembly method IM B 5.

Assembly method IM B 5 defines the flange mounting of the drive without mounting feet with two bearing plates, free front shaft end and mounting flange close to the bearing.

Rated torque M_N [mNm]

Maximum continuous torque (S1 mode) at nominal voltage at which in the steady-state condition the temperature does not exceed the maximum permissible winding temperature and/or the operating temperature range of the motor. The motor is fastened to a metal flange here, which approximates the amount of cooling available from a typical mounting configuration of the motor. This value can be exceeded if the motor is operated intermittently, for example, in S2 mode and/or if more cooling is applied.

Rated current I_N [A]

Typical maximum continuous current in the steady-state condition which results from the rated torque in continuous operation. This value can be exceeded if the drive is operated intermittently, in start/stop mode, in the starting phase and/or if more cooling is used.

Rated speed n_N [min⁻¹]

Typical rated speed in the steady-state condition which is determined from the given rated torque.

This value takes into account the effects that motor losses have on the slope of the n/M characteristic curve.

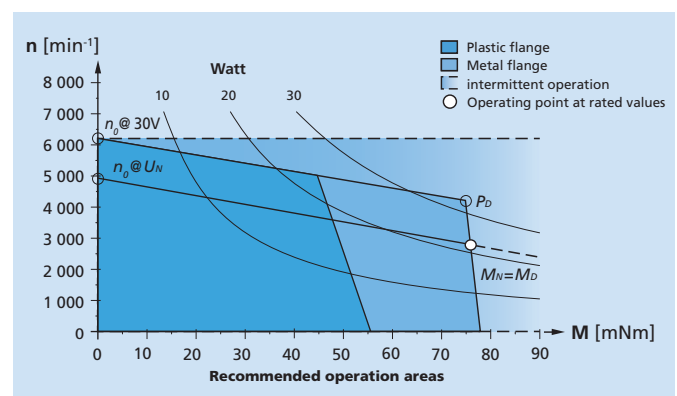

Example: Performance diagram for rated values with continuous operation.

Motion Control Systems V3.0

Technical Information

Explanations on the Performance Diagram

The possible speed ranges are shown in dependence on the shaft torque. The performance diagram shows the possible operating points of the servo-drives.

Operating points in the dark blue area are reached continually in the case of pure flange mounting (IM B5) on a plastic flange (approx. 100mm x 100mm x 10mm) and at an ambient temperature of 22 °C.

Operating points in the light blue area up to PD are reached continually in the case of pure flange mounting (IM B5) on an aluminium flange (approx. 100mm x 100mm x 10mm) and at an ambient temperature of 22 °C.

The maximum achievable speed depends on the motor supply voltage. At nominal voltage, the maximum achievable operating points are those on the nominal voltage line through the no-load point and nominal point.

Speeds above the nominal voltage line are reached at an increased supply voltage. In this case, the maximum voltage for the electronics or motor supply must never be exceeded.

The sector shown dashed describes possible operating points in which the drive can be engaged in intermittent operation or with increased cooling.

Continuous torque M_D [mNm]

Describes the max. recommended continuous torque in the steady-state condition at nominal voltage and mounting on an aluminium flange. With Motion Control Systems, the continuous torque simultaneously corresponds to the rated torque.

Here, the speed is linear to the continuous torque. The continuous torque is independent of the continuous output power and can be exceeded if the motor is operated intermittently, for example, in S2 operation and/or if more cooling is applied.

Continuous output P_D [W]

Describes the max. possible output power in continuous operation in steady-state condition with mounting on an aluminium flange. The value is independent of the continuous torque, responds linearly to the cooling factor and can be exceeded if the motor is operated intermittently, for example, in S2 operation and/or if more cooling is applied.

Nominal voltage curve U_N [V]

The nominal voltage curve describes the possible continuous operating points at U_N . In steady state, the starting point corresponds to the no-load speed n_0 of the drive. Operating points above this curve can be attained by an increase, operating points below by a reduction of the nominal voltage.



Easy commissioning with the new Motion Manager 6.

Depending on the cooling factor, operating point and ambient temperature, it may be necessary to adjust the current limitation parameters using the operating software. See technical manual for details.

Notes



Brushless DC-Servomotor with integrated Motion Controller

The 3564...B Cx series stands out first and foremost due to its extremely constant speed control coupled with very smooth-running operation.

These features make the servo-drive with compact integrated Motion Controller ideal for use in vibration-sensitive applications, e.g. in optics, in welding and balancing machines used in special machinery construction as well as in measuring or weighing systems. Integrated current control limits the torque of the drive if necessary, reliably protecting the drive against overload.

The interface (RS232 or CANopen) allows simple connection to networks. The integration of motor and control electronics in a single unit minimises both space and wiring requirements, thereby simplifying installation and commissioning. The control electronics are already perfectly matched to the motor when the unit leaves the factory. Programming is simple and convenient using the Motion Manager.

Series

3564 ... B Cx

Key Features

Motor diameter	□ 40 x 54 mm
Motor length	84 mm
Nominal voltage	24 V
Speed	up to 14.000 min ⁻¹
Torque	up to 71 mNm
Continuous output	up to 73 W



Product Code

35	Motor diameter [mm]
64	Motor length [mm]
K	Shaft type
024	Nominal voltage [V]
B	Product family
CS	Integrated Motion Controller, RS232 interface

FAULHABER B Cx

Advantages of this series at a glance

- Wide speed range from 1 to 14,000 min⁻¹
- RS232 or CANopen interface, adapter for connection to USB interface
- Compact mounting concept with integrated current limitation
- Simple and convenient programming using the Motion Manager and programming adapter
- Minimal wiring requirements
- Smooth running operation



Brushless DC-Servomotor with integrated Motion Controller

The highly dynamic positioning systems of generation V2.5 are available in two motor diameters with integrated, diameter-compliant Motion Controllers or with mounted, highly compact Motion Controllers. The different versions with their high torque, outstanding volume/performance ratio as well as highly dynamic control characteristics are suitable for a wide variety of market sectors, e.g. medical and laboratory technology, automation technology, robotics or special machinery construction. Integrated current control limits the torque of the drive if necessary, reliably protecting the drive against overload.

The interface (RS232 or CANopen) allows simple connection to networks. The integration of motor and control electronics in a single unit minimises both space and wiring requirements, thereby simplifying installation and commissioning. The control electronics are already perfectly matched to the motor when the unit leaves the factory. Programming is simple and convenient using the Motion Manager.

Series

2232 ... BX4 CxD	2250 ... BX4 CxD
3242 ... BX4 Cx	3268 ... BX4 Cx

Key Features

Motor diameter	Ø 22; □ 40 x 54 mm
Motor length	50 ... 90 mm
Nominal voltage	12 ... 24 V
Speed	up to 11.300 min ⁻¹
Torque	up to 96 mNm
Continuous output	up to 48 W



22 32 S 024 BX4 CS D

Product Code

22	Motor diameter [mm]
32	Motor length [mm]
S	Shaft type
024	Nominal voltage [V]
BX4	Product family
CS	Integrated Motion Controller, RS232 interface
D	Diameter-compliant

WE CREATE MOTION

FAULHABER BX4 CxD/Cx

Advantages of this series at a glance

- Wide speed range from 1 to 11,300 min⁻¹
- RS232 or CANopen interface, adapter for connection to USB interface
- Compact mounting concept with integrated current limitation
- Simple and convenient programming using the Motion Manager and programming adapter
- Minimal wiring requirements
- Smooth running operation

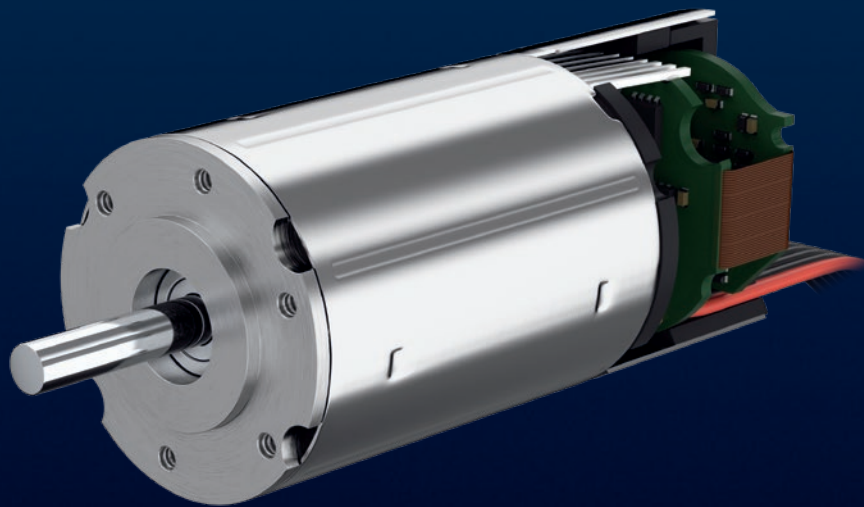

Brushless DC-Servomotor with integrated Motion Controller

The motion control systems of the most recent generation V3.0 are available in three performance classes with a continuous torque of 76 to 160 mNm. The drives comprise a brushless DC-Servomotor, a high-resolution actual value encoder and a Motion Controller in a complete, compact drive unit. The large number of different communication interfaces, the highly dynamic controllability, the robust design with protection class IP 54 as well as the industry standard connection concept via M12 connectors enable use in industrial environments ranging from automation technology and industrial special machinery construction to robotics and aerospace.

In combination with precision gearheads or high-quality lead screw systems, this results in complete system solutions for a wide variety of different applications. The systems can be used with any of the interface variants, both as stand-alone axes or in slave mode at various master controls. Furthermore, flexible usage possibilities are supported by various libraries and application notes that are available for download on the home page. All features of the drives are available here without restriction via all of the standard interfaces.

Series

MCS3242 ... BX4 RS/CO	MCS3242 ... BX4 ET
MCS3268 ... BX4 RS/CO	MCS3268 ... BX4 ET
MCS3274 ... BP4 RS/CO	MCS3274 ... BP4 ET

Key Features

Motor diameter	□ 42 x 50 mm
Motor length	75 ... 100 mm
Nominal voltage	24 V
Speed	up to 11.600 min ⁻¹
Torque	up to 160 mNm
Continuous output	up to 140 W



Product Code

MCS	Motion Control System
3242	Motor series
G	Shaft type
024	Nominal voltage [V]
BX4	Product family
ET	EtherCAT interface

FAULHABER MCS

Advantages of this series at a glance

- Maximum torque in compact installation space
- Interfaces: RS232, CANopen, EtherCAT, configuration via USB
- Optionally available with protection class IP 54
- Simple and convenient programming using the Motion Manager and programming adapter
- Standardised plug and connection cable concept
- Can be universally used in slave or stand-alone operation
- Extensive protective and diagnostic functions, local status LEDs

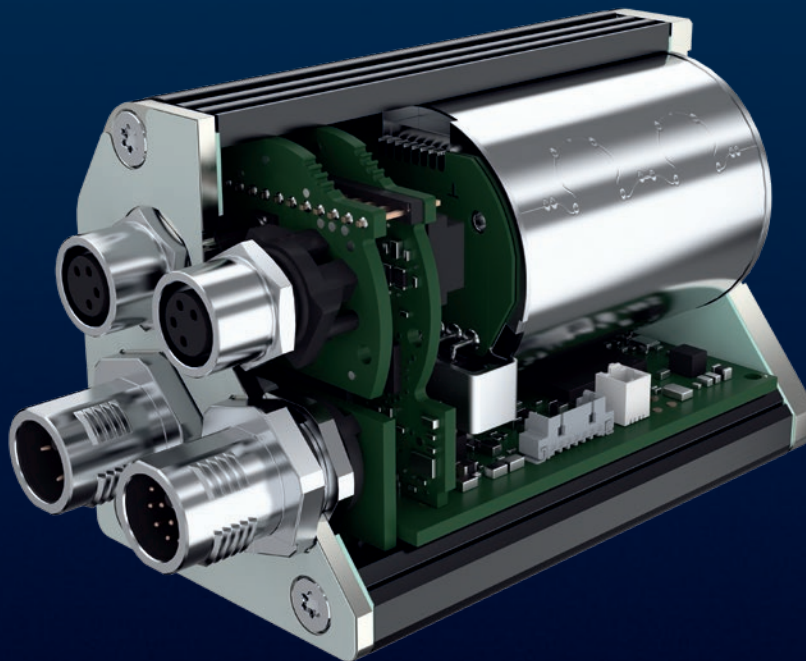

Stepper Motors

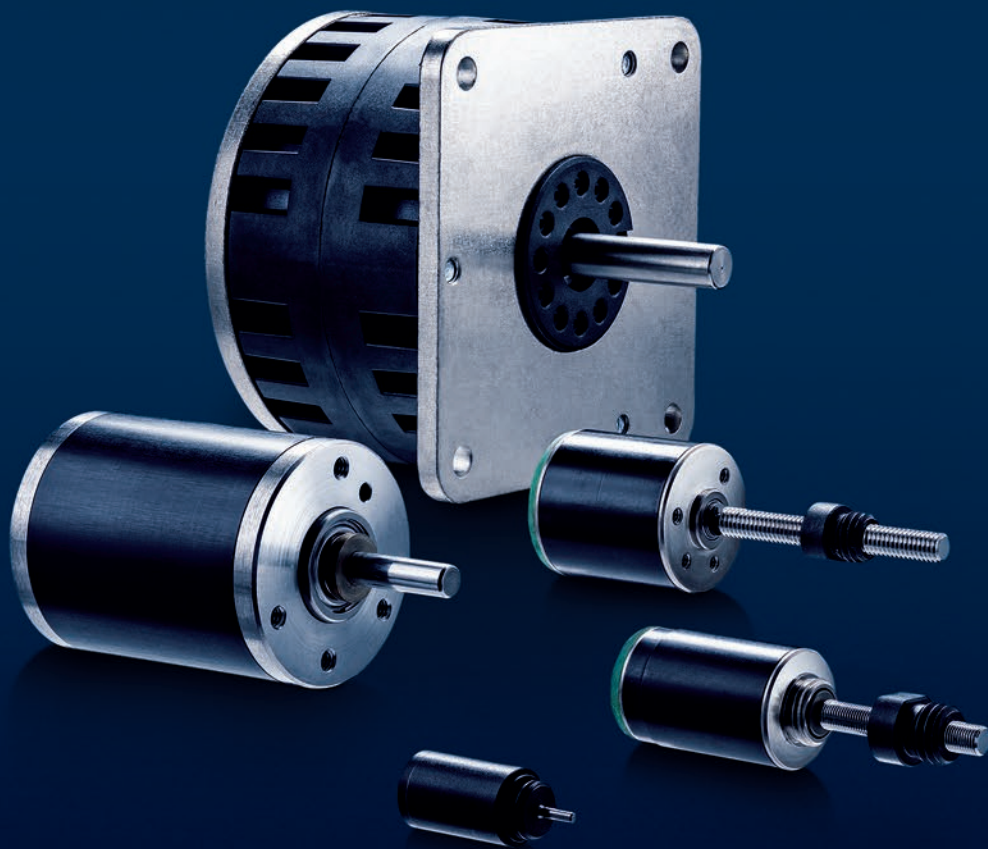

Stepper Motors

Technical Information

Stepper Motors	
Two phase with Disc Magnet, 20 steps per revolution	
Series DM0620	
Values at 20°C	DM0620
Nominal current per phase (both phases ON)	
Boosted current per phase (both phases ON)	
Nominal voltage per phase (both phases ON)	
Phase resistance	
Phase inductance (1 kHz)	
Holding torque (at nominal current)	

Notes on technical datasheet

Nominal current per phase I_0 [A]

The current supplied to the motor phases that will not exceed, at an ambient temperature of 20 °C, the thermal limits of the motor.

Boosted current per phase [A]

Maximum current which can be supplied to the motor phases for a short period of time not to exceed the thermal capacity of the motor.

Nominal voltage per phase [V]

Voltage necessary to reach the nominal current per phase.

Phase resistance [Ω]

Winding resistance per phase. Tolerance +/- 12%, steady state.

Phase inductance [mH]

Winding inductance per phase measured at 1kHz.

Holding torque M [mNm]

The torque generated by the motor at nominal current.

Holding torque at boosted current $M_{boosted}$ [mNm]

The torque the motor generates at boosted current. The magnetic circuit of the motor will not be affected by this boosted current, however, to avoid thermal overload the motor should only be boosted intermittently.

Residual torque, typ [mNm]

The typical torque applied to the shaft to rotate it without current to the motor. Residual torque is useful to hold a position without any current to save battery life or to reduce motor temperature.

Back-EMF amplitude [V/k step/s]

Amplitude of the back-EMF measured at 1000 steps/s.

Electrical time constant [ms]

Time needed to establish 63% of the max. possible phase current under a given operation point.

Rotor inertia J [kgm²]

This value represents the inertia of the complete rotor.

Step angle (full step) [degree]

Number of angular degrees the motor moves per full-step.

Angular accuracy [% of full step]

The percentage position error per full step, at no load and nominal current. This error is not cumulative between steps.

Angular acceleration, max [rad/s²]

Maximum acceleration the motor can reach in boosted mode and without any load.

$$\alpha_{max} = \frac{M_{boosted}}{J}$$

Resonance frequency (at no load) [Hz]

The step rate at which the motor at no load will demonstrate resonance. The resonance frequency is load dependent. For the best results the motor should be driven at a higher frequency or in half-step or microstepping mode outside of the given frequency.

$$f = \frac{1}{2\pi} \cdot \sqrt{\frac{M}{J}}$$

Thermal resistance R_{th1} ; R_{th2} [K/W]

R_{th1} corresponds to the value between the coil and the housing. R_{th2} corresponds to the value between the housing and the ambient air. R_{th2} can be reduced by enabling exchange of heat between the motor and the ambient air (for example using a heat sink or forced air cooling). If only one value is provided, R_{th} , it is the equivalent resistance between the coil and the air.

Thermal time constant τ_{w1} ; τ_{w2} [s]

The thermal time constant specifies the time needed for the winding respectively the housing to reach a temperature equal to 63% of the final steady state value.

Operating temperature range [°C]

Temperatures at which the motor can operate.

Winding temperature, max. [°C]

Maximum temperature supported by the windings and the magnets.

Shaft bearings

Self lubricating sintered sleeve bearings or preloaded ball bearings are available.

Stepper Motors

Technical Information

Shaft load, max. [N]

The output shaft load at a specified shaft diameter for the front output shaft. For motors with ball bearings the load and lifetime are in accordance with the values given by the bearing manufacturers. This value does not apply to second, or rear shaft ends. In case of ball bearings, if the bearing preload is exceeded, reversible shaft displacement of $\sim 200\mu\text{m}$ may occur.

Shaft play max. [mm]

The play between the shaft and bearings.

Housing material

Material of the motor housing.

Mass [g]

Is the motor mass in grams.

Magnet material

The basic type of magnet used in the standard motor.

How to select a Stepper Motor

The selection of a stepper motor requires the use of published torque speed curves based on the load parameters.

It is not possible to verify the motor selection mathematically without the use of the curves.

To select a motor the following parameters must be known:

- Motion profile
- Load friction and inertia
- Required resolution
- Available space
- Available power supply voltage

1. Definition of the load parameters at the motor shaft

The target of this step is to determine a motion profile needed to move the motion angle in the given time frame and to calculate the motor torque over the entire cycle using the application load parameters such as friction and load inertia.

The motion and load profiles of the movement used in this example are shown below.

Depending on the motor size suitable for the application it is required to recompute the load parameters with the motor inertia as well.

In the present case it is assumed that a motor with an outside diameter of maximum 15 mm is suitable and the data has been computed with the inertia of the AM1524.

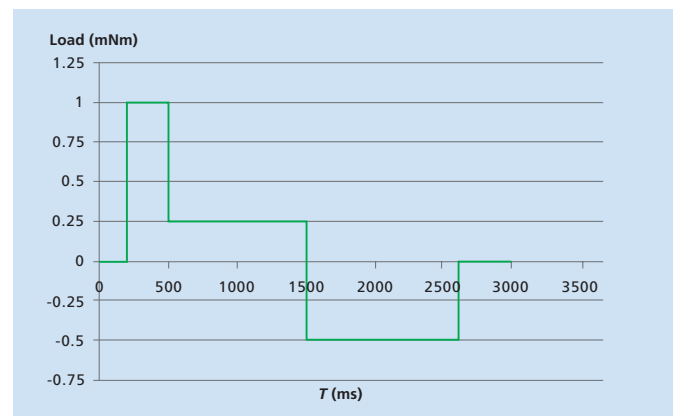
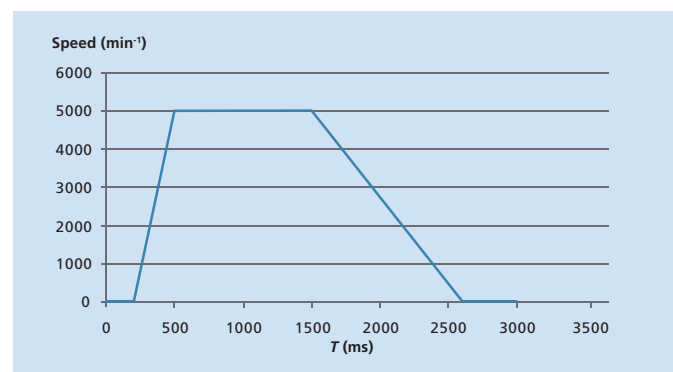

2. Verification of the motor operation.

The highest torque/speed point for this application is found at the end of the acceleration phase. The top speed is then $n = 5000 \text{ min}^{-1}$, the torque is $M = 1 \text{ mNm}$.

Using these parameters you can transfer the point into the torque speed curves of the motor as shown here with the AM1524 curves.

To ensure the proper operation of the motor in the application, it is highly recommended to use a design margin of 30% during the torque calculation. The shown example assures that the motor will correctly fulfil the requested application conditions.

The use of a higher supply voltage (typically 2.5 to 5 x higher than the nominal voltage) provides a higher torque at higher speed (please refer to the torque-speed curves).

In case no solution is found, it is possible to adapt the load parameters seen by the motor by the use of a reduction gearhead.

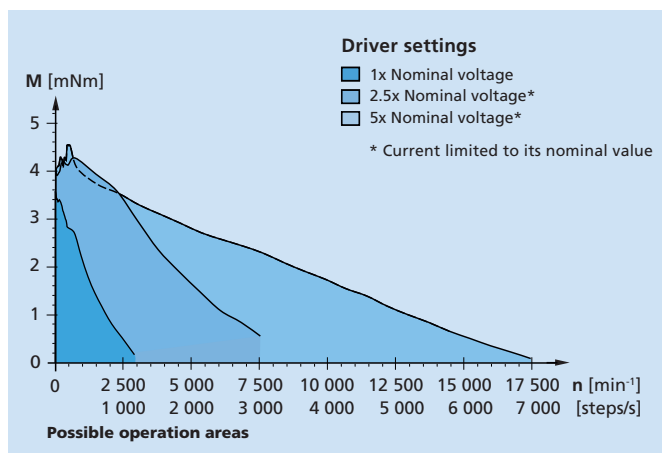

3. Verification of the resolution

It is assumed that the application requires a 9° angular resolution.

The motor selected, the AM1524, has a full step angle of 15° which is not suitable in full step mode. It can be operated either in half-step, or in microstepping. With microstepping, the resolution can be increased even higher but the angular accuracy is reduced because the error angle (expressed in % of a full-step) is independent from the number of microsteps.

For that reason the most common solution for adapting the motor resolution to the application requirements is the use of a gearhead or a lead-screw where linear motion is required.

4. Operation at low speed

All stepper motors exhibit a resonance frequency. These are typically below 100Hz. When operating at this frequency stepper motors will exhibit uncontrolled perturbations in speed, direction of rotation and a reduced torque. Thus, if the application requires a speed lower or equal to the resonance frequency, it is recommended to drive the motor in microstepping mode where the higher the microstepping rate, the better performance can be achieved. This will greatly decrease the effects of the resonant frequency and result in smoother speed control.

5. Verification in the application

Any layout based on such considerations has to be verified in the final application under real conditions.

Please make sure that all load parameters are taken into account during this test.

Direction of rotation

All motors will rotate in CCW direction when using the following commutation sequence : 1.A+B+ 2.A-B+ 3.A-B- 4.A+B-. Only exception is the AM1524 which runs CW using here above commutation sequence.

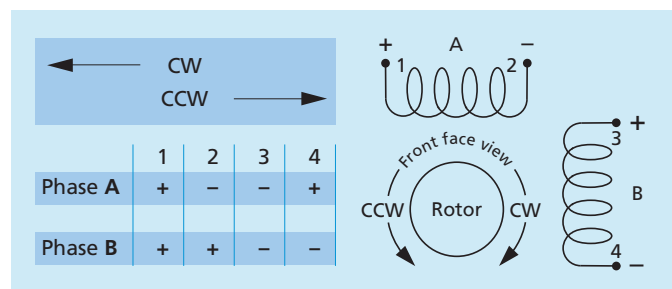

Stepper Motors

Technical Information

General application notes

In principle each stepper motor can be operated in three modes: full step (one or two phases on), half step or microstep.

Holding torque is the same for each mode as long as dissipated power (I^2R losses) is the same. The theory is best presented on a basic motor model with two phases and one pair of poles where mechanical and electrical angle are equal.

- In full step mode (1 phase on) the phases are successively energised in the following way:
1. A+ 2. B+ 3. A- 4. B-
- Half step mode is obtained by alternating between 1-phase-on and 2-phases-on, resulting in 8 half steps per electrical cycle: 1. A+ 2. A+B+ 3. B+ 4. A-B+ 5. A- 6. A-B- 7. B- 8. A+B-
- If every half step should generate the same holding torque, the current per phase is multiplied by $\sqrt{2}$ each time only 1 phase is energised.

The two major advantages provided by microstep operation are lower running noise and higher resolution, both depending on the number of microsteps per full step limited by the capability of the controller.

As explained above, one electrical cycle or revolution of the field vector (4 full steps) requires the driver to provide a number of distinct current values proportional to the number of microsteps per full step.

For example, 8 microsteps require 8 different values which in phase A would drop from full current to zero following the cosine function from 0° to 90° , and in phase B would rise from zero to full following the sine function.

These values are stored and called up by the program controlling the chopper driver. The rotor target position is determined by the vector sum of the torques generated in phase A and B:

$$M_A = k \cdot I_A = k \cdot I_o \cdot \cos \varphi$$

$$M_B = k \cdot I_B = k \cdot I_o \cdot \sin \varphi$$

where M is the motor torque, k is the torque constant and I_o the nominal phase current.

For the motor without load the position error is the same in full, half or microstep mode and depends on distortions of the sinusoidal motor torque function due to detent torque, saturation or construction details (hence on the actual rotor position), as well as on the accuracy of the phase current values.

Stepper Motors

Basic design

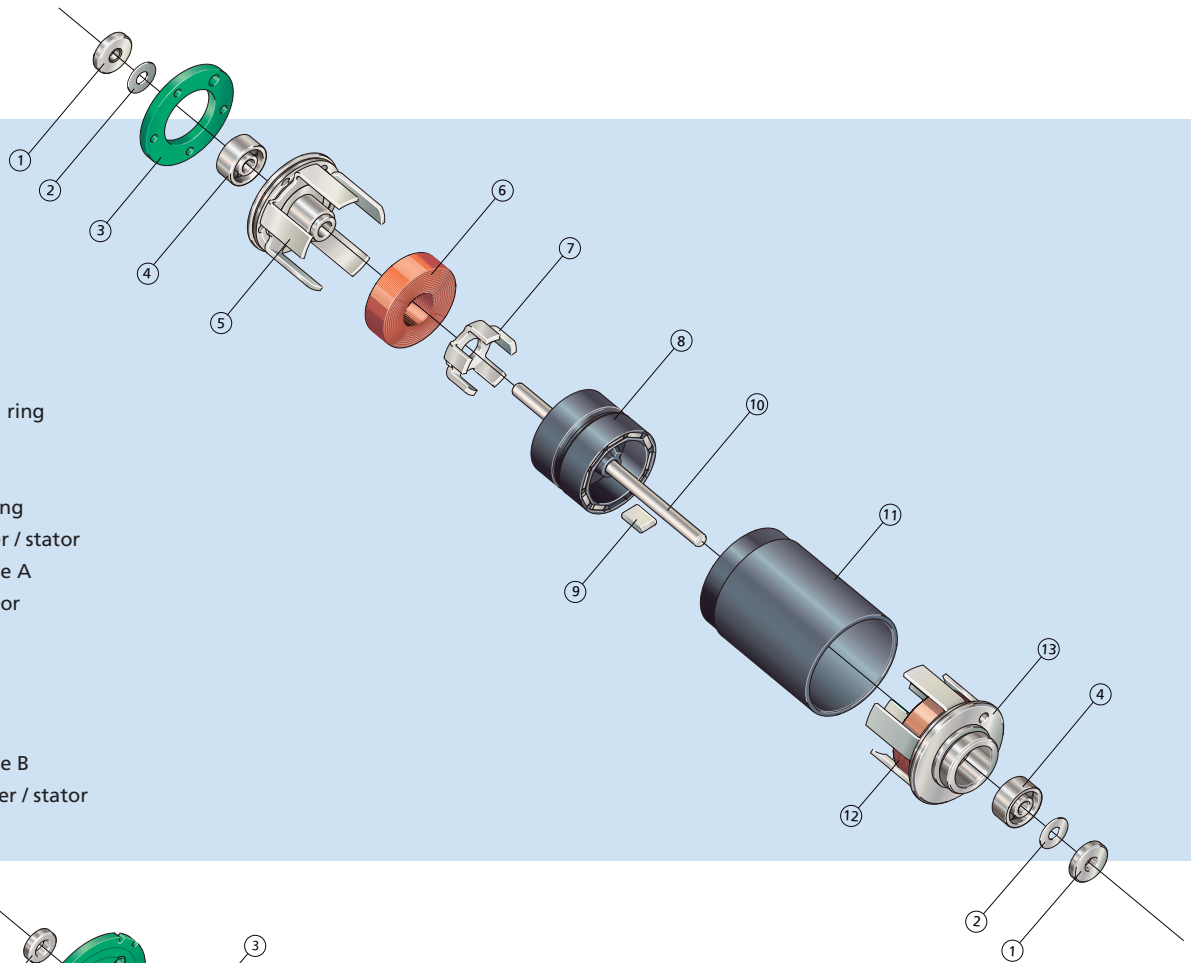

Two phase

- ① Retaining ring
- ② Washer
- ③ PCB
- ④ Ball bearing
- ⑤ Rear cover / stator
- ⑥ Coil, Phase A
- ⑦ Inner stator
- ⑧ Rotor
- ⑨ Magnets
- ⑩ Shaft
- ⑪ Housing
- ⑫ Coil, Phase B
- ⑬ Front cover / stator

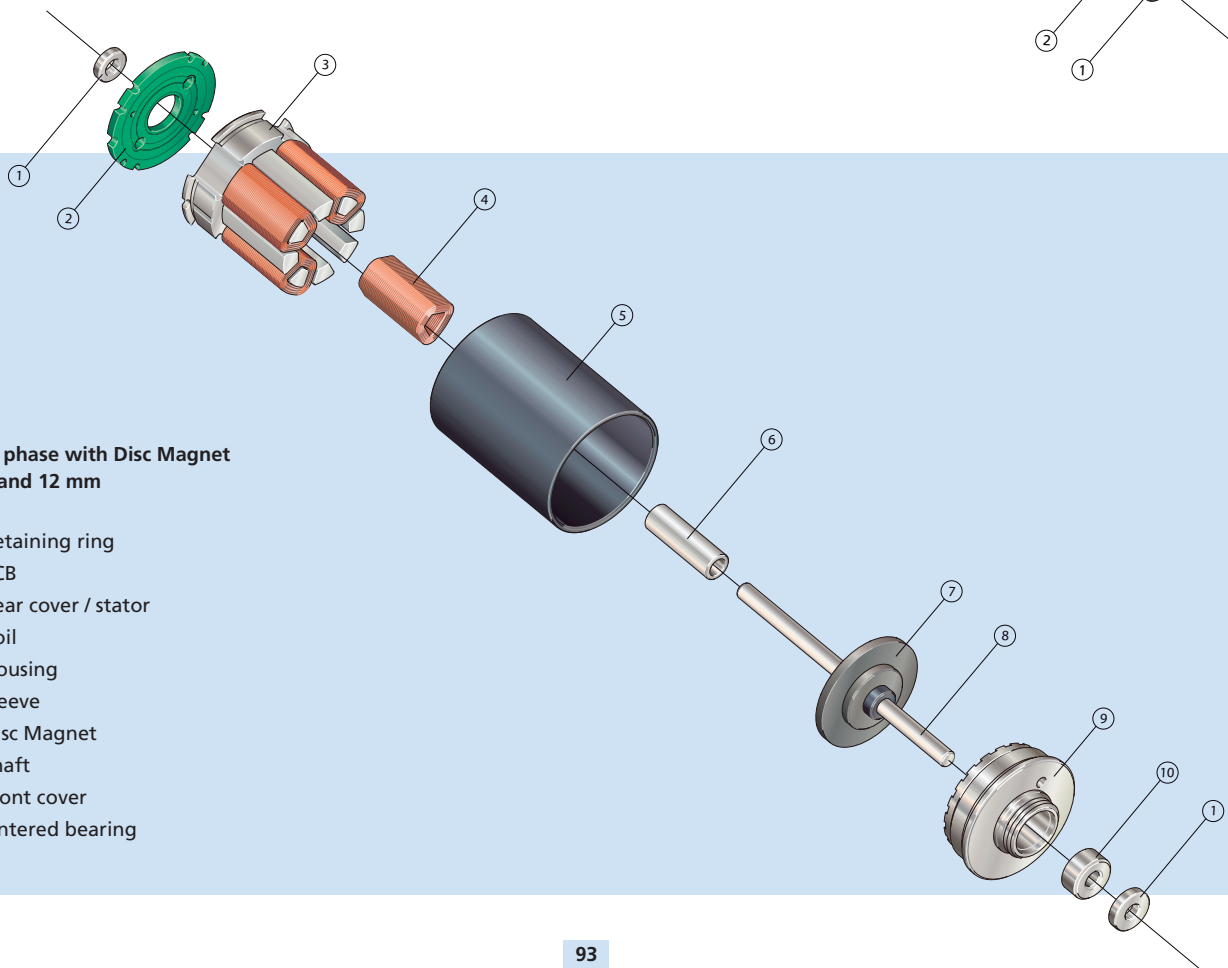

Two phase with Disc Magnet Ø 6 and 12 mm

- ① Retaining ring
- ② PCB
- ③ Rear cover / stator
- ④ Coil
- ⑤ Housing
- ⑥ Sleeve
- ⑦ Disc Magnet
- ⑧ Shaft
- ⑨ Front cover
- ⑩ Sintered bearing

Stepper Motors

Basic design

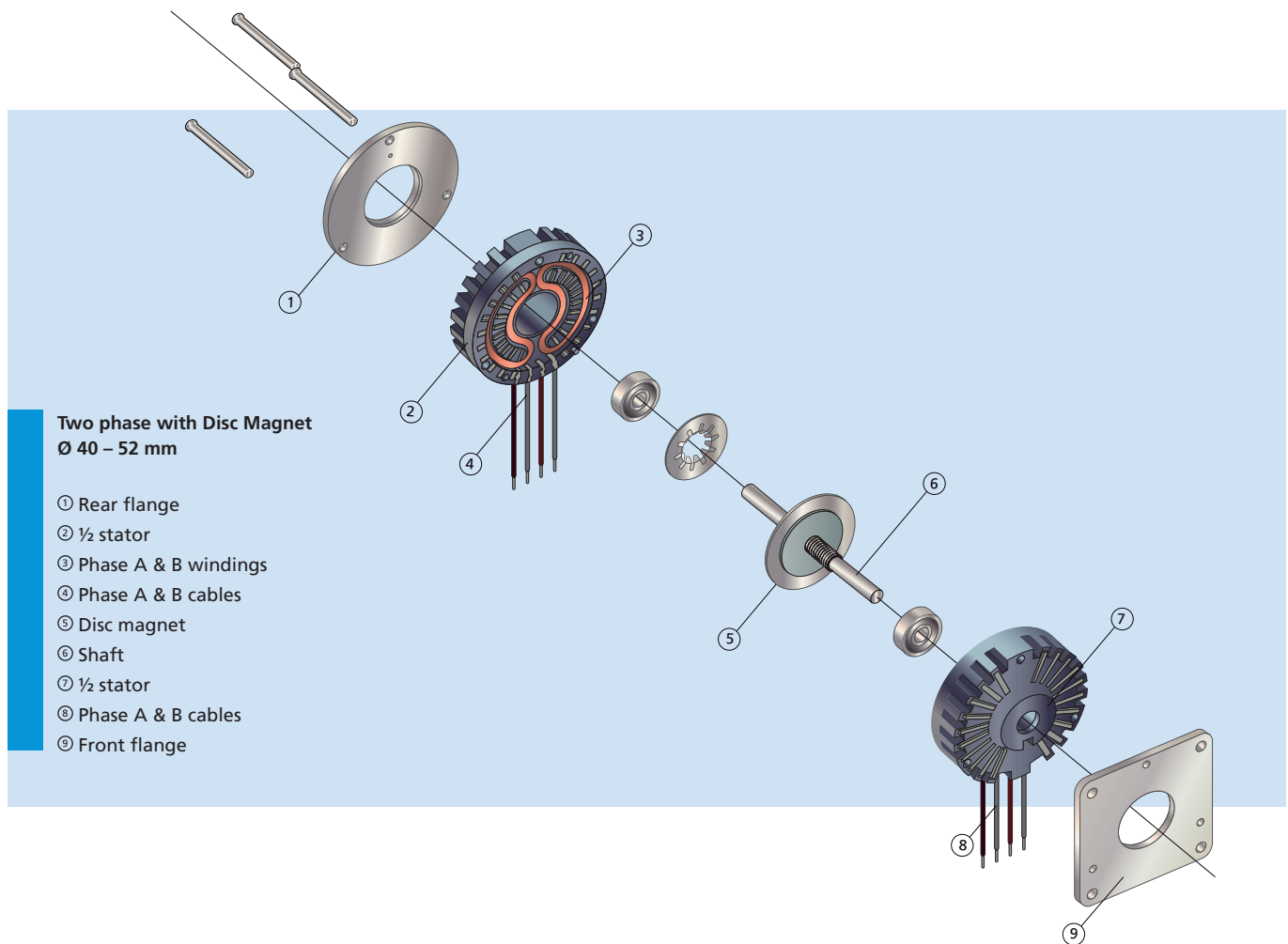

Notes

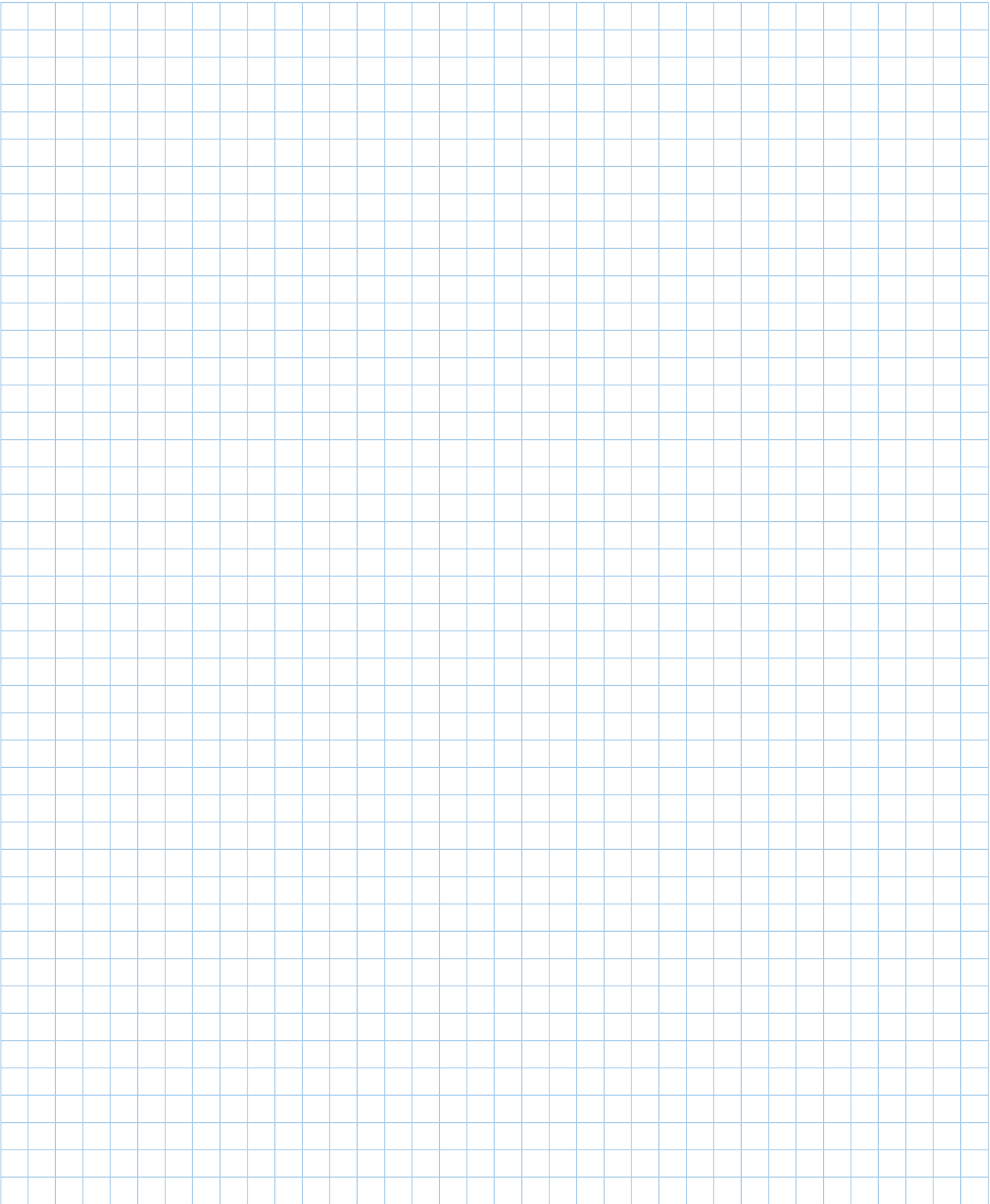

Stepper motors – 2 phases permanent magnet Technology

The FAULHABER stepper motors are two phase multi-polar motors with permanent magnets. The use of rare-earth magnets provides an exceptionally high power to volume ratio. Their rotor design with very low inertia makes them ideally suited for applications requiring very fast acceleration or change of directions and allows to start from the first step with a given speed, reducing further time needed for the acceleration ramp. Their short length and light weight allow them to be used in highly integrated systems.

Thanks to a robust design they can be selected for the harshest environments. Precise, open-loop, speed and position control can be achieved with the application of full step, half step, or microstepping electronics.

The FAULHABER stepper motors can be combined with lead-screws or gearheads enabling to reach operational points that are today unmatched in the market.

Series

DM0620	AM2224R3
AM0820	DM40100R
AM1020	DM52100S
DM1220	DM52100R
AM1524	DM52100N
AM2224	

Key Features

Outer diameter	6 ... 52 mm
Motor length	9,5 ... 32,6 mm
Number of steps per revolution	20 / 24 / 100
Holding torque (boost)	0,25 (0,39) ... 200 (450) mNm



DM 0620 2R 0080 11

Product Code

DM	Motor design
06	Motor diameter [mm]
20	Steps per revolution
-	Version (if applicable)
2R	Bearings
0080	Winding
11	Motor execution

FAULHABER Steppers

Advantages of this series at a glance

- Cost effective positioning drive without encoder
- High power density
- Very high acceleration
- Ultra-fast change of direction capability
- Long operational lifetimes
- Wide operational temperature range
- Speed range up to 16 000 min⁻¹ using a current mode chopper driver
- Possibility of full step, half step and microstep operation
- Extremely low rotor inertia

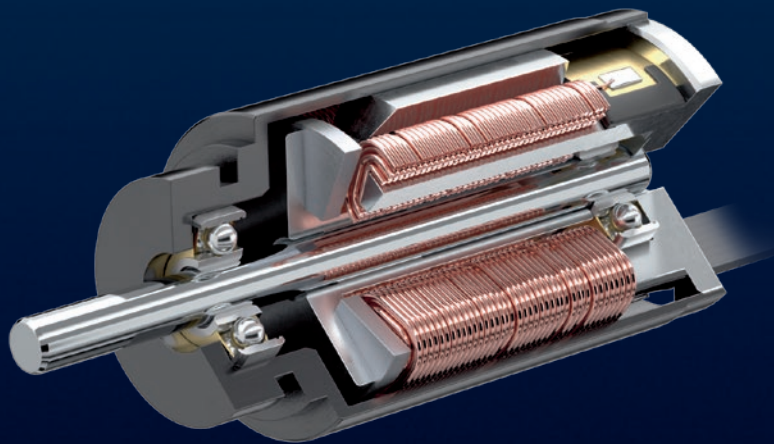

Linear DC-Servomotors



Linear DC-Servomotors

Technical Information

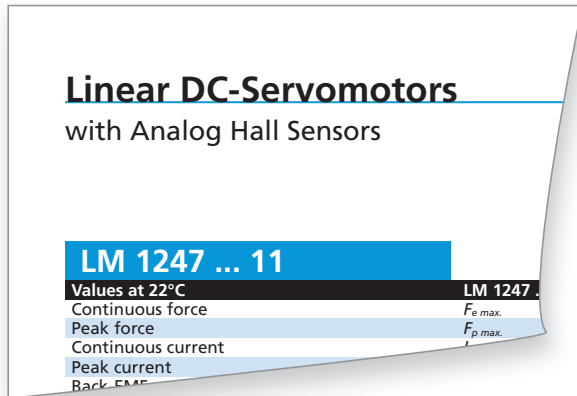

Notes on technical datasheet

All values at 22 °C.

Continuous force $F_{e \max.}$ [N]

The maximum force delivered by the motor at the thermal limit in continuous duty operation and with a reduced thermal resistance R_{th2} by 55%.

$$F_{e \max.} = k_F \cdot I_{e \max.}$$

Peak force $F_{p \max.}$ [N]

The maximum force delivered by the motor at the thermal limit in intermittent duty operation (max. 1 s, 10% duty cycle) and with a reduced thermal resistance R_{th2} by 55%.

$$F_{p \max.} = k_F \cdot I_{p \max.}$$

Continuous current $I_{e \max.}$ [A]

The maximum motor current consumption at the thermal limit in continuous duty operation and with a reduced thermal resistance R_{th2} by 55%.

$$I_{e \max.} = \sqrt{\frac{T_{125} - T_{22}}{R \cdot (1 + \alpha_{22} \cdot (T_{125} - T_{22})) \cdot (R_{th1} + 0,45 \cdot R_{th2})}} \cdot \frac{\sqrt{2}}{\sqrt{3}}$$

Peak current $I_{p \max.}$ [A]

The maximum motor current consumption at the thermal limit in intermittent duty operation (max. 1 s, 10% duty cycle) and with a reduced thermal resistance R_{th2} by 55%.

Back-EMF constant k_E [V/m/s]

The constant corresponding to the relationship between the induced voltage in the motor phases and the linear motion speed.

$$k_E = \frac{2 \cdot k_F}{\sqrt{6}}$$

Force constant k_F [N/A]

The constant corresponding to the relationship between the motor force delivered and the motor line current with sine wave commutation.

Terminal resistance, phase-phase R [Ω] $\pm 12\%$

The resistance measured between two motor phases.

This value is directly influenced by the coil temperature (temperature coefficient: $\alpha_{22} = 0,0038 \text{ K}^{-1}$).

Terminal inductance, phase-phase L [μH]

The inductance measured between two phases at 1 kHz.

Stroke length $s_{\max.}$ [mm]

The datasheet parameters are only valid if the rod movement is within the given stroke range, $s_{\max.}$. Aligning the rod and stator axial centres, the allowed movement is therefore half the overall stroke length.

Repeatability σ_r [μm]

The typical measured difference when repeating several times the same movement under the same conditions.

Measurements done with FDS MC (-01, 11 versions) and 3rd party sin/cos motion controller (-02, 12 versions).

Accuracy σ_a [μm]

The typical positioning error. This value corresponds to the difference between the set position and the exact measured position of the system. Measurements done with FDS MC (-01, 11 versions) and 3rd party sin/cos motion controller (-02, 12 versions).

Acceleration $a_{e \max.}$ [m/s^2]

The maximum theoretical no-load acceleration from standstill in continuous duty operation.

$$a_{e \max.} = \frac{F_{e \max.}}{m_m}$$

Speed $v_{e \max.}$ [m/s]

The maximum theoretical no-load speed from standstill, considering a triangular speed profile and maximum stroke length.

$$v_{e \max.} = \sqrt{a_{e \max.} \cdot s_{\max.}}$$

Thermal resistance R_{th1} ; R_{th2} [K/W]

R_{th1} corresponds to the value between coil and housing.

R_{th2} corresponds to the value between housing and ambient air.

The listed values refer to a motor totally surrounded by air.

R_{th2} can be reduced with a heat sink and/or forced air cooling.

Linear DC-Servomotors

Technical Information

Thermal time constant $\tau_{w1}; \tau_{w2}$ [s]

The thermal time constant of the coil (τ_{w1}) and housing (τ_{w2}), respectively.

Operating temperature range [°C]

The minimum and maximum permissible operating temperature values of the motors.

Rod weight m_m [g]

The typical weight of the rod (cylinder with magnets).

Total weight m_t [g]

The typical total weight of the linear DC-Servomotor.

Magnetic pitch τ_m [mm]

The distance between two equal poles.

Rod bearings

The material and type of bearings.

Housing material

The material of the motor housing.

Direction of movement

The direction of movement is reversible, determined by the control electronics.

Force calculation

To move a mass on a slope, the motor needs to deliver a force to accelerate the load and overcome all forces opposing the movement.

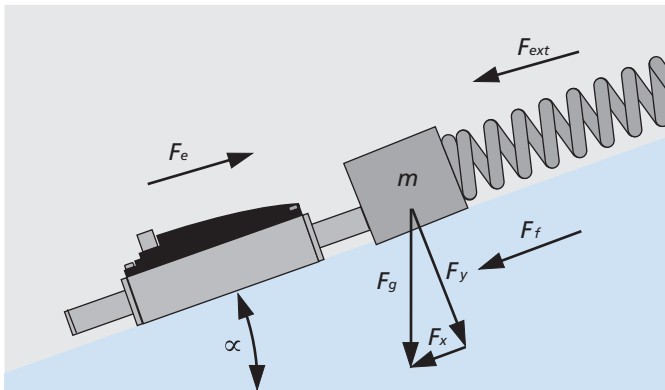

The sum of forces shown in above figure has to be equal to:

$$\sum F = m \cdot a \quad [\text{N}]$$

Entering the various forces in this equation it follows that:

$$F_e - F_{ext} - F_f - F_x = m \cdot a \quad [\text{N}]$$

where:

F_e :	Continuous force delivered by motor	[N]
F_{ext} :	External force	[N]
F_f :	Friction force $F_f = m \cdot g \cdot \mu \cdot \cos(\alpha)$	[N]
F_x :	Parallel force $F_x = m \cdot g \cdot \sin(\alpha)$	[N]
m :	Total mass (incl. rod)	[kg]
g :	Gravity acceleration	[m/s ²]
a :	Acceleration	[m/s ²]

Speed profiles

Shifting any load from point A to point B is subject to the laws of kinematics.

Equations of a uniform straight-line movement and uniformly accelerated movement allow definition of the various speed vs. time profiles.

Prior to calculating the continuous duty force delivered by the motor, a speed profile representing the various load movements needs to be defined.

Triangular speed profile

The triangular speed profile simply consists of an acceleration and a deceleration time.

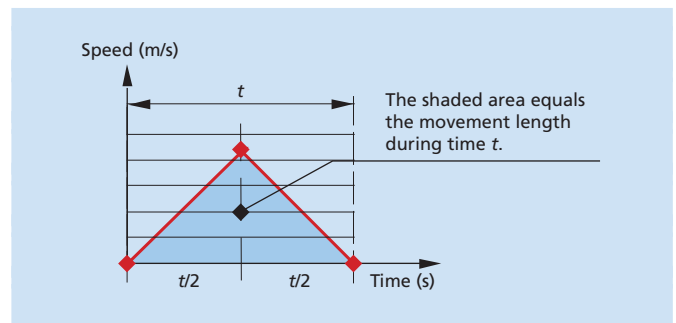

Displacement: $s = \frac{1}{2} \cdot v \cdot t = \frac{1}{4} \cdot a \cdot t^2 = \frac{v^2}{a} \quad [\text{m}]$

Speed: $v = 2 \cdot \frac{s}{t} = \frac{a \cdot t}{2} = \sqrt{a \cdot s} \quad [\text{m/s}]$

Acceleration: $a = 4 \cdot \frac{s}{t^2} = 2 \cdot \frac{v}{t} = \frac{v^2}{s} \quad [\text{m/s}^2]$

Trapezoidal speed profile

The trapezoidal speed profile, acceleration, speed and deceleration, allow simple calculation and represent typical real application cases.

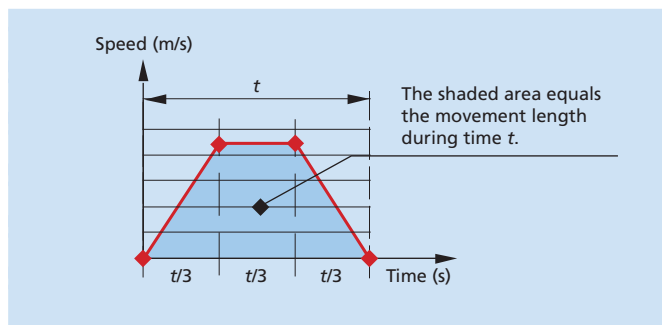

Displacement: $s = \frac{2}{3} \cdot v \cdot t = \frac{1}{4,5} \cdot a \cdot t^2 = 2 \cdot \frac{v^2}{a}$ [m]

Speed: $v = 1,5 \cdot \frac{s}{t} = \frac{a \cdot t}{3} = \sqrt{\frac{a \cdot s}{2}}$ [m/s]

Acceleration: $a = 4,5 \cdot \frac{s}{t^2} = 3 \cdot \frac{v}{t} = 2 \cdot \frac{v^2}{s}$ [m/s²]

How to select a linear DC-Servomotor

This section describes a step-by-step procedure to select a linear DC-Servomotor.

Speed profile definition

To start, it is necessary to define the speed profile of the load movements.

Movement characteristics are the first issues to be considered. Which is the maximum speed? How fast should the mass be accelerated? Which is the length of movement the mass needs to achieve? How long is the rest time?

Should the movement parameters not be clearly defined, it is recommended to use a triangular or trapezoidal profile.

Let's assume a total mass of 500 g that needs to be moved 20 mm in 100 ms on a slope having a rising angle of 20° considering a trapezoidal speed profile.

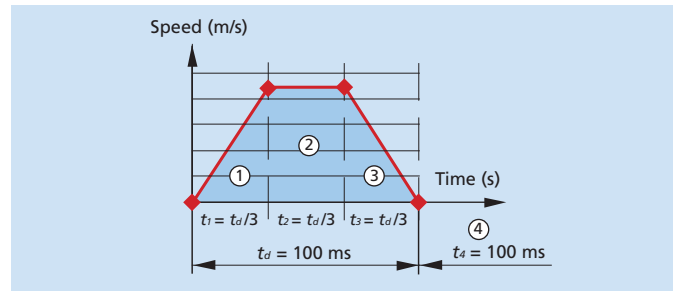

	Unit	①	②	③	④
s (displacement)	m	0,005	0,01	0,005	0
v (speed)	m/s	0 ... 0,3	0,3	0,3 ... 0	0
a (acceleration)	m/s ²	9,0	0	-9,0	0
t (time)	s	0,033	0,033	0,033	0,100

Calculation example

Speed and acceleration of part ①

$$v_{max} = 1,5 \cdot \frac{s}{t} = 1,5 \cdot \frac{20 \cdot 10^{-3}}{100 \cdot 10^{-3}} = 0,3 \text{ m/s}$$

$$a = 4,5 \cdot \frac{s}{t^2} = 4,5 \cdot \frac{20 \cdot 10^{-3}}{(100 \cdot 10^{-3})^2} = 9 \text{ m/s}^2$$

Force definition

Assuming a total mass of 500 g and a friction coefficient of 0,2, the following forces result:

Force	Unit	Symbol	Forward				Backward			
			①	②	③	④	①	②	③	④
Friction	N	F_f	0,94	0,94	0,94	-0,94	0,94	0,94	0,94	0,94
Parallel	N	F_x	1,71	1,71	1,71	1,71	-1,71	-1,71	-1,71	-1,71
Acceleration	N	F_a	4,5	0	-4,5	0	4,5	0	-4,5	0
Total	N	F_t	7,15	2,65	-1,85	0,77	3,73	-0,77	-5,27	-0,77

Calculation example

Friction and acceleration forces of part ①

$$F_f = m \cdot g \cdot \mu \cdot \cos(\alpha) = 0,5 \cdot 10 \cdot 0,2 \cdot \cos(20^\circ) = 0,94 \text{ N}$$

$$F_a = m \cdot a = 0,5 \cdot 9 = 4,5 \text{ N}$$

Motor selection

Now that the forces of the three parts of the profile are known, requested peak and continuous forces can be calculated in function of the time of each part.

The peak force is the highest one achieved during the motion cycle.

$$F_p = \max(|7,15|, |2,65|, |-1,85|, |0,77|, |3,73|, |-0,77|, |-5,27|, |-0,77|) = 7,15 \text{ N}$$

Linear DC-Servomotors

Technical Information

The continuous force is represented by the expression:

$$F_e = \sqrt{\frac{\sum (t \cdot F_t^2)}{2 \cdot \sum t}} = \dots$$

$$F_e = \sqrt{\frac{0,033 \cdot 7,15^2 + 0,033 \cdot 2,65^2 + 0,033 \cdot (-1,85)^2 + 0,1 \cdot 0,77^2 + 0,033 \cdot 3,73^2 + 0,033 \cdot (-0,77)^2 + 0,033 \cdot (-5,27)^2 + 0,1 \cdot (-0,77)^2}{2 \cdot (0,033 + 0,033 + 0,033 + 0,1)}} = 2,98 \text{ N}$$

With these two values it is now possible to select the suitable motor for the application.

Linear DC-Servomotor **LM 1247-020-11**

$s_{max.} = 20 \text{ mm}$; $F_{e \text{ max.}} = 3,6 \text{ N}$; $F_p \text{ max.} = 10,7 \text{ N}$

Coil winding temperature calculation

To obtain the coil winding temperature, the continuous motor current needs to be calculated.

For this example, considering a force constant k_f equal to 6,43 N/A, gives the result:

$$I_e = \frac{F_e}{k_f} = \frac{2,98}{6,43} = 0,46 \text{ A}$$

With an electrical resistance of 13,17 Ω , a total thermal resistance of 23,2 $^{\circ}\text{C}/\text{W}$ ($R_{th1} + R_{th2}$) and a reduced thermal resistance R_{th2} by 55% ($0,45 \cdot R_{th2}$), the resulting coil temperature is:

$$T_c (I) = \frac{R \cdot (R_{th1} + 0,45 \cdot R_{th2}) \cdot (I_e \cdot \frac{\sqrt{3}}{2})^2 \cdot (1 - \alpha_{22} \cdot T_{22}) + T_{22}}{1 - \alpha_{22} \cdot R \cdot (R_{th1} + 0,45 \cdot R_{th2}) \cdot (I_e \cdot \frac{\sqrt{3}}{2})^2} = \dots$$

$$T_c (I) = \frac{13,17 \cdot (3,2 + 0,45 \cdot 20,0) \cdot (0,46 \cdot \frac{\sqrt{3}}{2})^2 \cdot (1 - 0,0038 \cdot 22) + 22}{1 - 0,0038 \cdot 13,17 \cdot (3,2 + 0,45 \cdot 20,0) \cdot (0,46 \cdot \frac{\sqrt{3}}{2})^2} = 85,26 \text{ }^{\circ}\text{C}$$

Motor characteristic curves

Motion profile:

Trapezoidal ($t1 = t2 = t3$), back and forth

Motor characteristic curves of the linear DC-Servomotor with the following parameters:

Displacement distance: 20 mm

Friction coefficient: 0,2

Slope angle: 20°

Rest time: 0,1 s

The motor characteristic curves are dependent on movement parameters (speed profile, displacement distance, friction coefficient, slope angle and rest time). Consequently by modifying one or more of these input data, the motor characteristic curves will change accordingly. Comparing the above diagram with the one reported in the datasheet of the LM 1247-020-11 it can immediately be seen that with the same linear motor we get different curves by only changing the slope angle (in this example 20° and in the datasheet 0°).

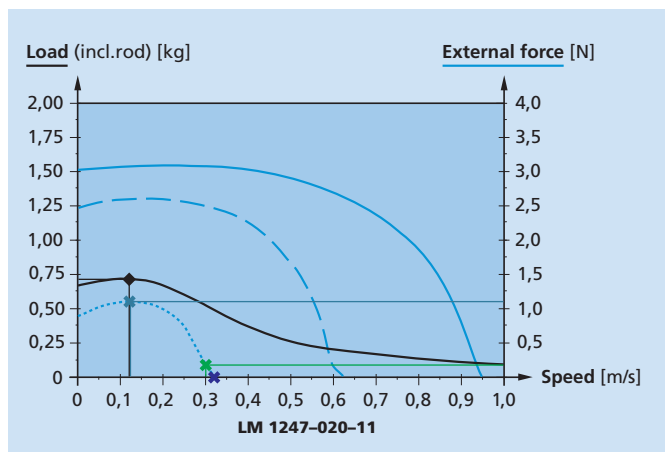

Load curve

Allows knowing the maximum applicable load (incl. rod) for a given speed with 0 N external force.

The graph shows that a maximum load (incl. rod) (◆) of 0,72 kg can be applied at a speed of 0,125 m/s.

External force curve

Allows knowing the maximum applicable external force for a given speed with a load of

- 0,1 kg —————
 - 0,2 kg - - - - -
 - 0,5 kg ·······

Considering the 0,5kg curve, the graph shows that the max. achievable speed without external forces, but with a load of 0,5 kg is 0,32 m/s (✕).

The maximum applicable external force (✕) at a speed of 0,3 m/s is 0,17 N.

The external peak force (✕) is achieved at a speed of 0,125 m/s, corresponding to a maximum applicable external force of 1,1 N.

Linear DC-Servomotors

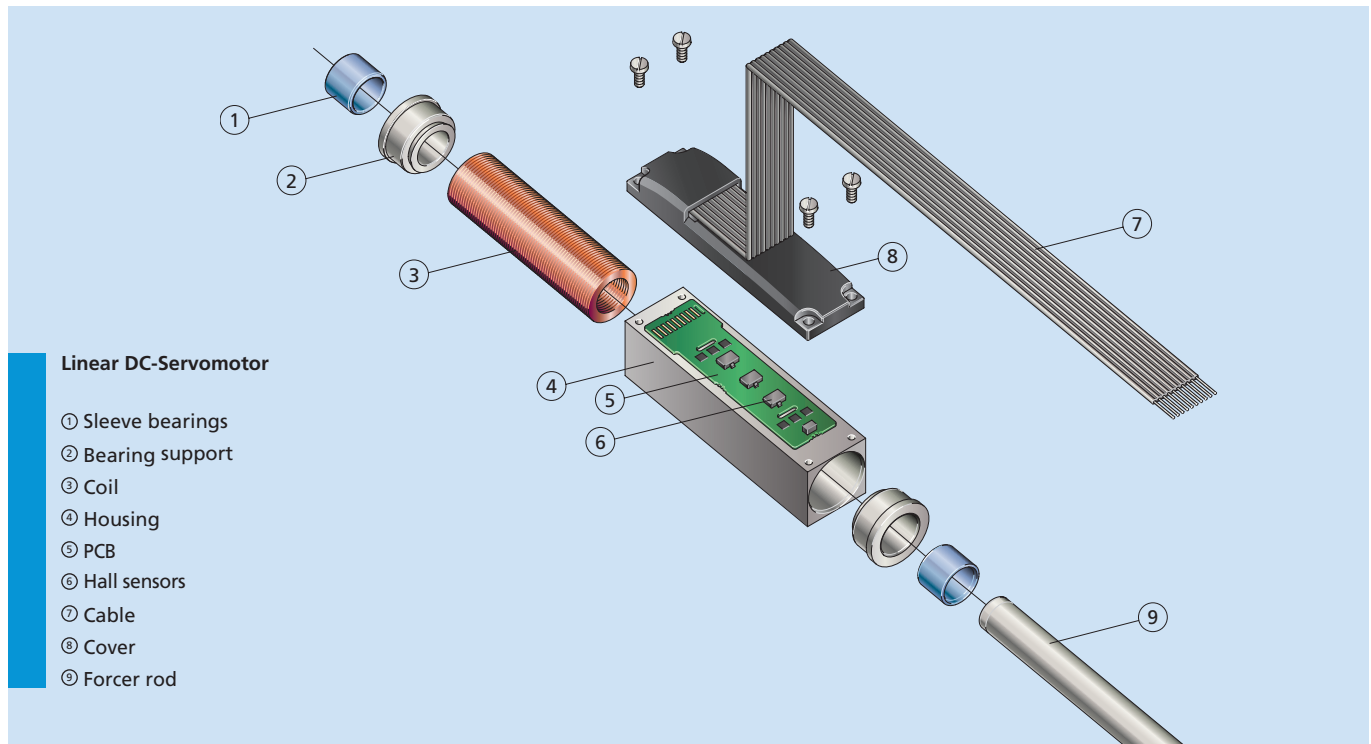

Linear DC-Servomotor

- ① Sleeve bearings
- ② Bearing support
- ③ Coil
- ④ Housing
- ⑤ PCB
- ⑥ Hall sensors
- ⑦ Cable
- ⑧ Cover
- ⑨ Forcer rod

Features

FAULHABER technology combines the speed and robustness of a pneumatic system with the flexibility and reliability features of an electro-mechanical linear motor. The innovative design with a 3-phase self-supporting coil and non-magnetic metal housing offers outstanding performance.

The absence of residual static force and the excellent relationship between the linear force and current make these motors ideal for use in micro-positioning applications. Position control of the Linear DC-Servomotor is made possible by the built-in Hall sensors.

Performance lifetime of the Linear DC-Servomotors is mainly influenced by the wear of the sleeve bearings, which depends on operating speed and applied load of the cylinder rod.

Benefits

- High dynamics
- Excellent force to volume ratio
- No residual force present
- Non-magnetic metal housing
- Compact and robust construction
- No lubrication required
- Simple installation and configuration

Product code



LM	Linear Motor
12	Motor width □ [mm]
47	Motor length [mm]
020	Stroke length [mm]
11	Sensors type: linear

LM1247-020-11

Precision Gearheads



Precision Gearheads

Technical Information

General information

Life performance

The operational lifetime of a reduction gearhead and motor combination is determined by:

- Input speed
- Output torque
- Operating conditions
- Environment and Integration into other systems

Since a multitude of parameters prevail in any application, it is nearly impossible to state the actual lifetime that can be expected from a specific type of gearhead or motor-gearhead combination. A number of options to the standard reduction gearheads are available to increase life performance: ball bearings, all metal gears, reinforced lubrication etc.

Bearings – Lubrication

Gearheads are available with a range of bearings to meet various shaft loading requirements: sintered sleeve bearings, ball bearings and ceramic bearings. Where indicated, ball bearings are preloaded with spring washers of limited force to avoid excessive current consumption.

A higher axial shaft load or shaft pressfit force than specified in the data sheets will neutralise the preload on the ball bearings.

The satellite gears in the 38/1-2 Series Planetary Gearheads are individually supported on sintered sleeve bearings. In the 38A and 44/1 Series, the satellite gears are individually supported on needle or ball bearings.

All bearings are lubricated for life. Relubrication is not necessary and not recommended. The use of non-approved lubricants on or around the gearheads or motors can negatively influence the function and life expectancy.

The standard lubrication of the reduction gears is such as to provide optimum life performance at minimum current consumption at no-load conditions. For extended life performance, all metal gears and heavy duty lubrication are available. Specially lubricated gearheads are available for operation at extended temperature environments and under vacuum.

Notes on technical datasheet

Unspecified tolerances

Tolerances in accordance with ISO 2768 medium.

≤ 6	=	± 0,1 mm
≤ 30	=	± 0,2 mm
≤ 120	=	± 0,3 mm

Input speed

The recommended maximum input speed for continuous operation serves as a guideline. It is possible to operate the gearhead at higher speeds. However, to obtain optimum life performance in applications that require continuous operation and long life, the recommended speed should be considered.

Ball bearings

Ratings on load and lifetime, if not stated, are according to the information from the ball bearing manufacturers.

Operating temperature range

Standard range as listed on the data sheets.

Special executions for extended temperature range available on request.

Reduction ratio

The listed ratios are nominal values only, the exact ratio for each reduction gearhead can be calculated by means of the stage ratio applicable for each type.

Output torque

Continuous operation.

The continuous torque provides the maximum load possible applied to the output shaft; exceeding this value will reduce the service life.

Intermittent operation.

The intermittent torque value may be applied for a short period. It should be for short intervals only and not exceed 5% of the continuous duty cycle.

Direction of rotation, reversible

All gearheads are designed for clockwise and counter-clockwise rotation. The indication refers to the direction of rotation as seen from the shaft end, with the motor running in a clockwise direction.

Backlash

Backlash is defined by the amount by which the width of a tooth space exceeds the width of the engaging tooth on the pitch circle. Backlash is not to be confused with elasticity or torsional stiffness of the system.

The general purpose of backlash is to prevent gears from jamming when making contact on both sides of their teeth simultaneously. A small amount of backlash is desirable to provide for lubricant space and differential expansion between gear components. The backlash is measured on the output shaft, at the last geartrain stage.

Precision Gearheads

Technical Information

Zero Backlash Gearheads

The spur gearheads, series 08/3, 12/5, 15/8, 16/8 and 22/5, with dual pass geartrains feature zero backlash when pre-loaded with a FAULHABER DC-Micromotor.

Preloaded gearheads result in a slight reduction in overall efficiency and load capability.

Due to manufacturing tolerances, the preloaded gearheads could present higher and irregular internal friction torque resulting in higher and variable current consumption in the motor.

However, the unusual design of the FAULHABER zero backlash gearheads offers, with some compromise, an excellent and unique product for many low torque, high precision positioning applications.

The preloading, especially with a small reduction ratios, is very sensitive. This operation is achieved after a defined burn-in in both directions of rotation. For this reason, gearheads with pre-loaded zero backlash are only available when factory assembled to the motor.

The true zero backlash properties are maintained with new gearheads only. Depending on the application, a slight backlash could appear with usage when the gears start wearing. If the wearing is not excessive, a new preload could be considered to return to the original zero backlash properties.

Assembly instructions

It is strongly recommended to have the motors and gearheads factory assembled and tested. This will assure perfect matching and lowest current consumption.

The assembly of spur and hybrid gearheads with motors requires running the motor at very low speed to ensure the correct engagement of the gears without damage.

The planetary gearheads must not be assembled with the motor running. The motor pinion must be matched with the planetary input-stage gears to avoid misalignment before the motor is secured to the gearhead.

When face mounting any gearhead, care must be taken not to exceed the specified screw depth. Driving screws beyond this point will damage the gearhead. Gearheads with metal housing can be mounted using a radial set screw.

How to select a Precision Gearhead

This section gives an example of a step-by-step procedure on how to select a reduction gearhead.

Application data

The basic data required for any given application are:

Required torque	M	[mNm]
Required speed	n	[min ⁻¹]
Duty cycle	δ	[%]
Available space, max.	diameter/length	[mm]
Shaft load	radial/axial	[N]

The assumed application data for the selected example are:

Output torque	M	=	120 mNm
Speed	n	=	30 min ⁻¹
Duty cycle	δ	=	100%
Space dimensions, max.	diameter	=	18 mm
	length	=	60 mm
Shaft load	radial	=	20 N
	axial	=	4 N

To simplify the calculation in this example, the duty cycle is assumed to be continuous operation.

Preselection

A reduction gearhead which has a continuous output torque larger than the one required in the application is selected from the catalogue.

If the required torque load is for intermittent use, the selection is based on the output torque for intermittent operation.

The shaft load, frame size and overall length with the motor must also meet the minimum requirements.

The product selected for this application is the planetary gearhead, type 16/7.

Output torque, continuous operation	$M_{max.}$	=	300 mNm
Recommended max. input speed for			
- Continuous operation	n	≤	5 000 min ⁻¹
- Shaft load, max.	radial	≤	30 N
	axial	≤	5 N

Calculation of the reduction ratio

To calculate the theoretical reduction ratio, the recommended input speed for continuous operation is divided by the required output speed.

$$i_N = \frac{\text{Recommended max. input speed}}{\text{required output speed}}$$

From the gearhead data sheet, a reduction ratio is selected which is equal to or less than the calculated one.

For this example, the reduction ratio selected is 159 : 1.

Calculation of the input speed n_{input}

$$n_{input} = n \cdot i \quad [\text{min}^{-1}]$$

$$n_{input} = 30 \cdot 159 = 4\,770 \quad \text{min}^{-1}$$

Calculation of the input torque M_{input}

$$M_{input} = \frac{M \cdot 100}{i \cdot \eta} \quad [\text{mNm}]$$

The efficiency of this gearhead is 60%, consequently:

$$M_{input} = \frac{120 \cdot 100}{159 \cdot 60} = 1,26 \quad \text{mNm}$$

The values of

Input speed	n_{input}	= 4 770	min ⁻¹
and			

Input torque	M_{input}	= 1,26	mNm
--------------	-------------	--------	-----

are related to the motor calculation.

The motor suitable for the gearhead selected must be capable of producing at least two times the input torque needed.

For this example, the DC-Micromotor type 1624 E 024 S supplied with 14 VDC will produce the required speed and torque.

For practical applications, the calculation of the ideal motor-gearhead drive is not always possible.

Detailed values on torque and speed are usually not clearly defined.

It is recommended to select suitable components based on a first estimation, and then test the units in the application by varying the supply voltage until the required speed and torque are obtained.

Recording the applied voltage and current at the point of operation, along with the type numbers of the test assembly, we can help you to select the ideal motor-gearhead.

The success of your product will depend on the best possible selection being made!

For confirmation of your selection and peace of mind, please contact our sales engineers.

Precision Gearheads

Planetary Gearheads

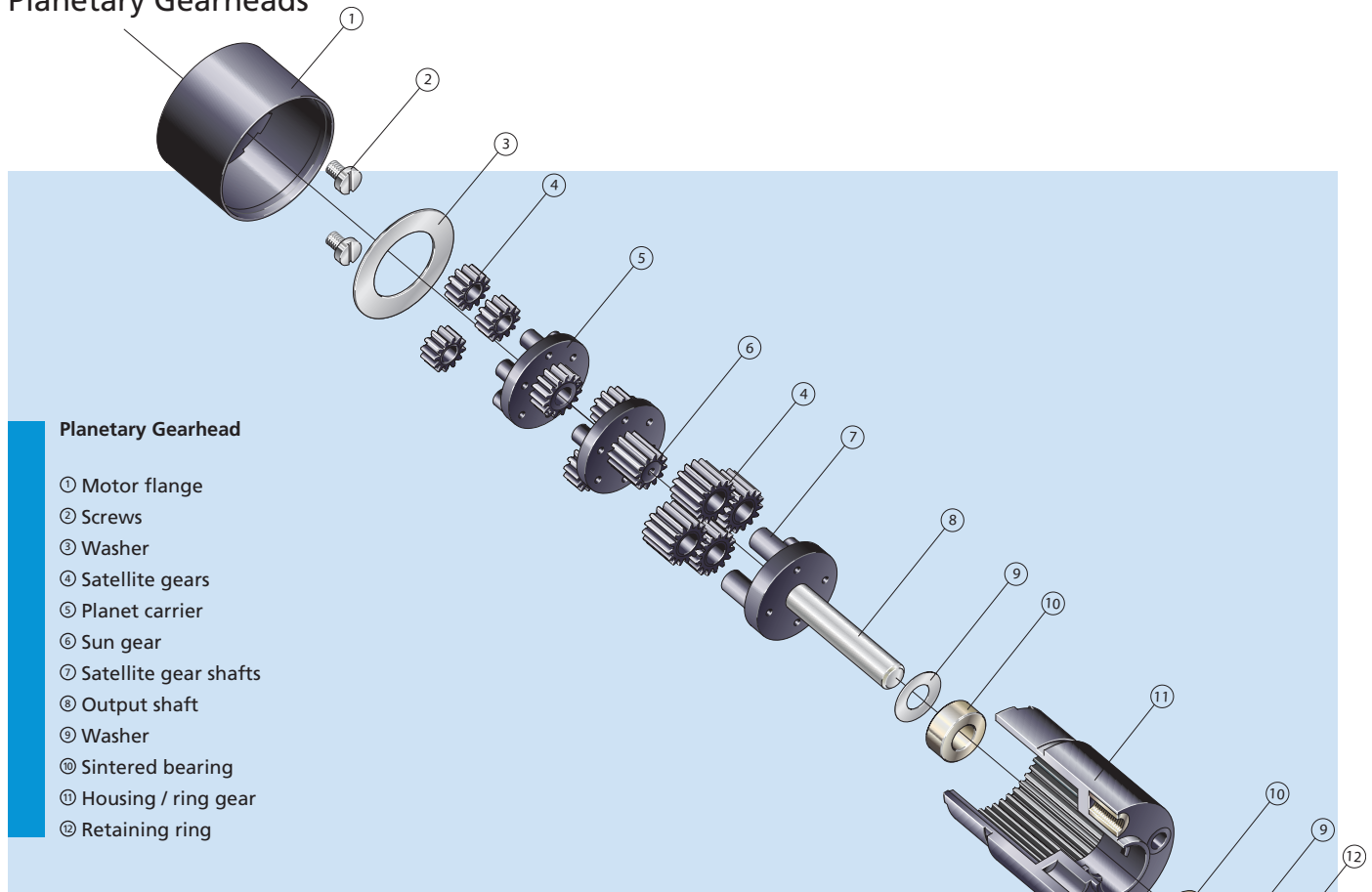

Planetary Gearhead

- ① Motor flange
- ② Screws
- ③ Washer
- ④ Satellite gears
- ⑤ Planet carrier
- ⑥ Sun gear
- ⑦ Satellite gear shafts
- ⑧ Output shaft
- ⑨ Washer
- ⑩ Sintered bearing
- ⑪ Housing / ring gear
- ⑫ Retaining ring

Features

Their robust construction make the planetary gearheads, in combination with FAULHABER DC-Micromotors, ideal for high torque, high performance applications. In most cases, the geartrain of the input stage is made of plastic to keep noise levels as low as possible at higher speed. All steel input gears as well as a modified lubrication are available for applications requiring very high torque, vacuum, or higher temperature compatability.

For applications requiring medium to high torque FAULHABER offers planetary gearheads constructed of high performance plastics. They are ideal solutions for applications where low weight and high torque density play a decisive role. The gearhead is mounted to the motor with a threaded flange to ensure a solid fit.

Benefits

- Available in all plastic or metal versions
- Use of high performance plastic and ceramic materials
- Available with a variety of shaft bearings including sintered, ceramic, and ball bearings
- Modified versions for extended temperature and special environmental conditions are available
- Custom modifications available

Product code

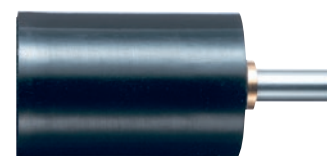

All metal planetary gearhead series 12/4

26	Outer diameter [mm]
A	Version
64:1	Reduction ratio

26A 64:1

Precision Gearheads

Spur Gearheads

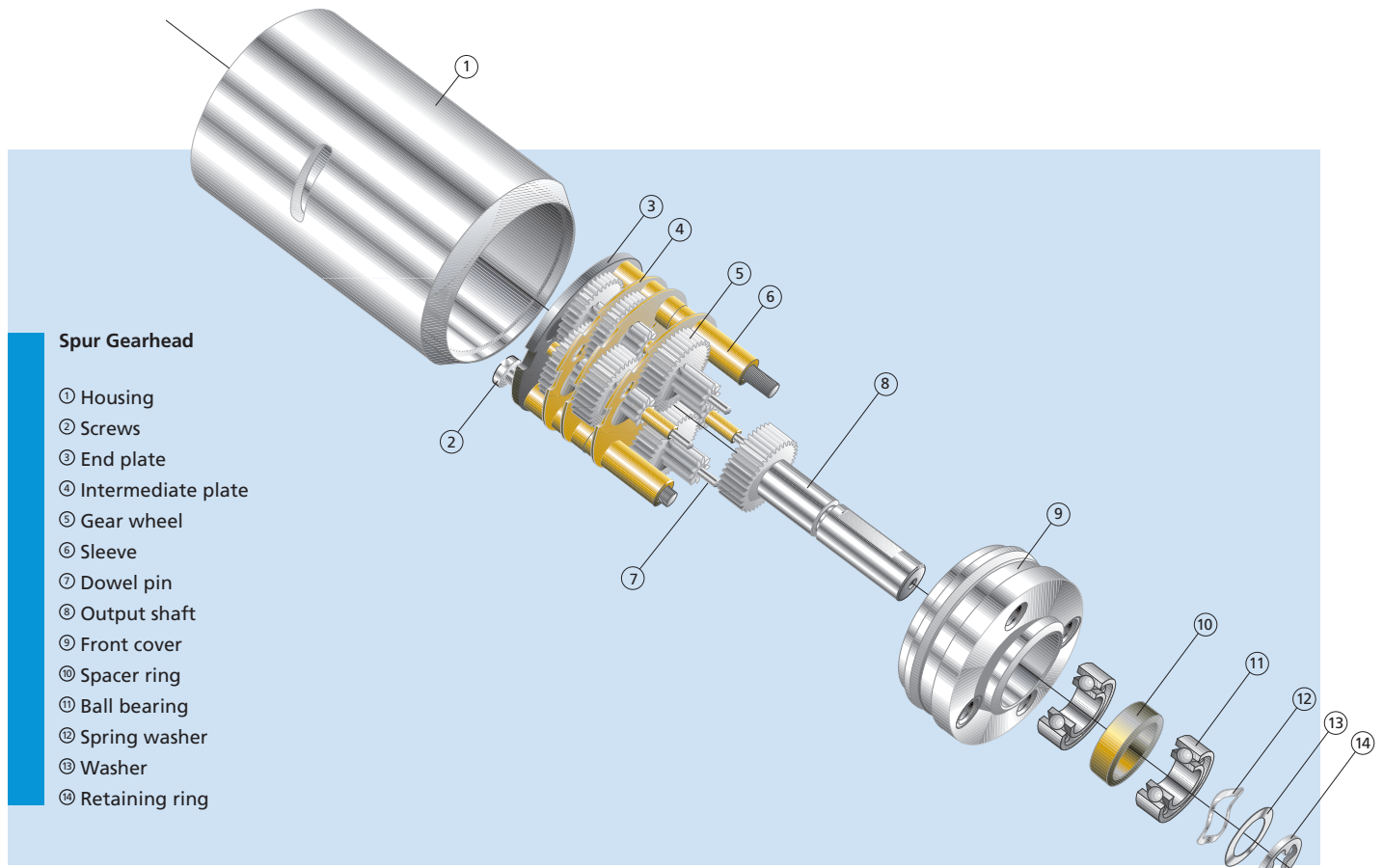

Spur Gearhead

- ① Housing
- ② Screws
- ③ End plate
- ④ Intermediate plate
- ⑤ Gear wheel
- ⑥ Sleeve
- ⑦ Dowel pin
- ⑧ Output shaft
- ⑨ Front cover
- ⑩ Spacer ring
- ⑪ Ball bearing
- ⑫ Spring washer
- ⑬ Washer
- ⑭ Retaining ring

Features

A wide range of high quality spur gearheads are available to compliment FAULHABER DC-Micromotors. The all metal or plastic input-stage geartrain assures extremely quiet running. The precise construction of the gearhead causes very low current consumption in the motor, giving greater efficiency. The gearhead is sleeve mounted on the motor, providing a seamless in-line fit. The FAULHABER Spur Gearheads are ideal for high precision, low torque and low noise applications.

gear passes to each other and locking them in place on the motor pinion gear. They are ideal for positioning applications with a very high resolution and moderate torque. Zero backlash gearheads can only be delivered preloaded from the factory.

Benefits

- Available in a wide variety of reduction ratios including very high ratios
- Zero backlash versions are available
- Available with a variety of shaft bearings including sintered, ceramic, and ball bearings

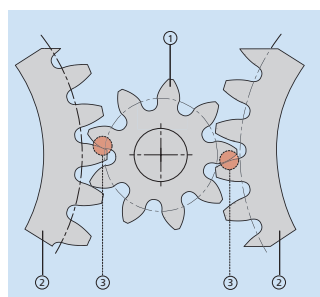

Zero Backlash Spur Gearhead

- ① Motor pinion
- ② Dual-pass geartrain input stage
- ③ Zero backlash preloaded engagement

FAULHABER offers a special version of a spur gearhead with zero backlash. These gearheads consist of a dual pass spur geartrain with all metal gears. The backlash is reduced to a minimum by counter-rotating the two individual

Product code



22	Outer diameter [mm]
/5	Version
377:1	Reduction ratio

22/5 377:1

Planetary Gearheads

The GPT planetary gearheads exhibit high torque and enhanced input speed in compact dimensions. Their improved efficiency and numerous reduction ratios uniformly distributed help to exploit the maximum motor power.

Their geartrain is designed for robustness to sustain intermittent or sudden load changes. Depending on the diameter size, these gearheads can sustain input speed up to 20.000 min⁻¹ or output torque up to 25 Nm when operating in intermittent cycles. The GPT product family is also particularly suited for accurate positioning applications granted by a low backlash characteristic.

These gearheads can be combined with an extensive range of DC or brushless motors and they come with various shaft configurations to adapt to many applications. They are ideal for different types of robots – inspection, assembly, rehabilitation or exoskeletons – as well as for production and laboratory automation, for packaging machines, measurement and testing equipment or for semiconductor handling.

Series

22GPT	32GPT
42GPT	

Key Features

Gearhead diameter	22 ... 42 mm
Material	stainless steel
Continuous torque	0,45 ... 18 Nm
Continuous input speed	up to 15.000 min ⁻¹
Intermittent torque	0,6 ... 25 Nm
Intermittent input speed	up to 20.000 min ⁻¹
Radial load	up to 390 N
Reduction ratio	from 3:1 up to 1294:1



22 GPT 89:1 KS1

Product Code

22	Gearhead diameter
GPT	Product family
89:1	Reduction ratio
KS1	Standard options

FAULHABER GPT

Advantages of this series at a glance

- Compact length
- High continuous torque
- Very robust for intermittent or impulsive cycles
- High intermittent speed up to 20.000 min⁻¹
- Reduced backlash
- Many reduction ratios
- Large selection of motor combinations
- Many standard options

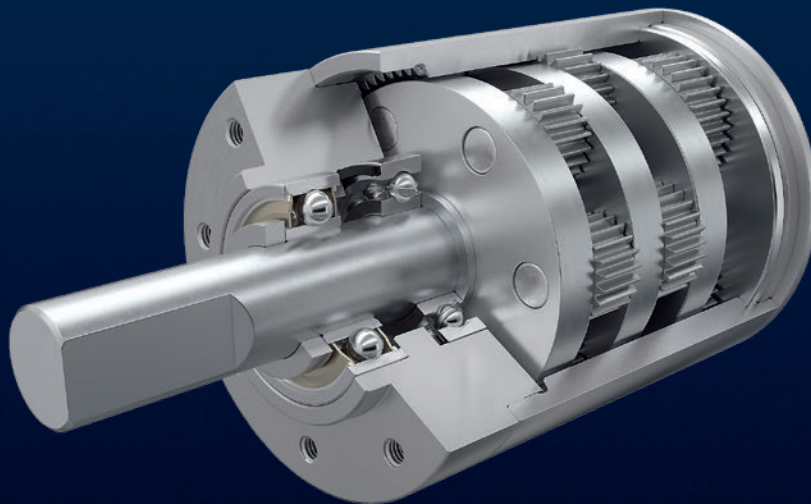

Precision Gearheads

Technical Information

General information

The FAULHABER GPT metal planetary gearhead series are designed to provide high torque in compact dimensions, they can support large input speeds and are suited for a wide range of applications like robotics, industrial machines and laboratory equipment. The GPT product family is designed to leverage at best the maximum power of FAULHABER DC-Micromotors and Brushless DC-Servomotors. Besides high torque performance, GPT series are also particularly well suited for positioning applications granted by their low backlash characteristics.

On top of optimizing performance for continuous operation, GPT series are also designed to sustain strong torque impulses and large speed variations when used in intermittent cycles. A large number of reduction ratios uniformly distributed are available to select the most appropriate configuration to fit various torque or speed operating points required by the application.

A large selection of options are available to match different ambient conditions and make the mechanical integration inside applications faster and smoother through various shaft configurations.

The main advantages of the GPT series are:

- compactness with short length
- high torque and high inputs speeds
- very robust with high intermittent or impulsive torque
- many reduction ratios
- minimum backlash
- high efficiency
- different shaft configurations
- large selection of motors combinations

Service Life

The operational lifetime of a reduction gearhead and motor combination is determined by:

- input speed and output torque, resulting in output power
- motor operating temperature
- operation mode (continuous, intermittent or impulsive) and duty cycle
- output shaft load (radial or axial load)
- operating conditions like temperature, dust and other ambient conditions
- environment and integration into other systems

Since a multitude of parameters prevail in any application, it is nearly impossible to state the actual lifetime that can be expected from a specific type of gearhead or motor-gearhead combination. A number of options to the standard reduction gearheads are available to increase life performance: ball bearings, different lubrication etc.

Bearings – Lubrication

Gearheads are available with different bearings to meet various requirements. Where indicated, ball bearings are preloaded with spring washers of limited force to avoid excessive current consumption.

A higher axial shaft load than specified in the data sheets will neutralize the preload on the ball bearings.

All bearings are lubricated for life. Relubrication is not necessary and not recommended. The use of non-approved lubricants on or around the gearheads or motors can negatively influence the function and life expectancy.

The standard lubrication of the reduction gears is such as to provide optimum life performance at minimum current consumption at no-load conditions. Special lubricated gearheads are available for operation at extended temperature environments and under vacuum.

Operating limits

In order to avoid short service life or early damage, gearheads are intended to be used within the following limits:

- maximum output torque
- and maximum input speed
- and maximum output power

Values at 22°C				
		1	2	2
Number of gear stages				
Reduction ratio (rounded) ¹⁾		3:1 3,6:1 4,5:1 6,6:1	9:1	11:1 14:1 16:1 20:1 24:1 30:1 44:1
Continuous torque, max.	Nm	0,45	0,8	0,8
Intermittent torque, max.	Nm	0,6	1,1	1,1
Peak torque	Nm	1	2,5	2,5
Continuous input speed, max.	min ⁻¹	9 000	10 000	12 000
Intermittent input speed, max.	min ⁻¹	11 000	12 000	15 000
Continuous output power, max.	W	21	12	12
Intermittent output power, max.	W	30	18	18
Efficiency, max.	%	92	84	83

An important aspect to consider is that gearhead cannot operate simultaneously at maximum output torque and maximum input speed, such operating condition would result in a power transmission generating excessive heat dissipation and would degrade significantly service life. For such reason, a limitation relative maximum output power is also specified in the datasheet.

These speed, torque and power limits are specified to different values depending on the operating mode, either continuous operation or intermittent operation, for which intermittent operation refers to an operating duty cycle of 20% on-time.

Those limits are represented in a graphical form to illustrate the recommended area of operations for continuous and intermittent operations. Such graph reports the output speed versus output torque on both logarithmic scales.

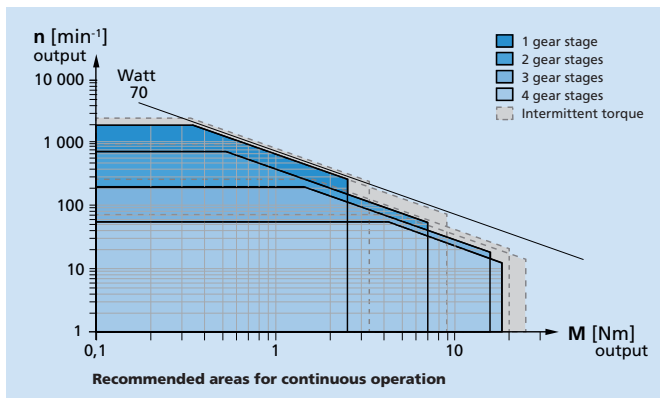

The limits also vary depending on the number of reduction stages and is also depending on the reduction ratio as expressed in the datasheet through the various columns reporting performance based on reduction ratios.

These limit values are referring to the only gearhead for ambient temperature around 22°C and do not consider any external effects relative to the gearhead. Ambient conditions, influence of integration in the system application and motor behavior like motor temperature are not considered when defining those maximum operating limits.

Efficiency

Datasheets report the maximum efficiency of the gearhead based on its configuration as per number of stage and reduction ratio. Such efficiency value refers only to continuous operation mode.

intermittent output power, max.	vv	30	18	18
Efficiency, max.	%	92	84	82

Such maximum efficiency occurs on a specific operating point in terms of speed and torque and it depends also on the gearhead configuration and on the specific reduction ratio.

For each specific configuration, the gearhead efficiency varies with speed and torque. The following graph reports the typical behavior of gearhead efficiency.

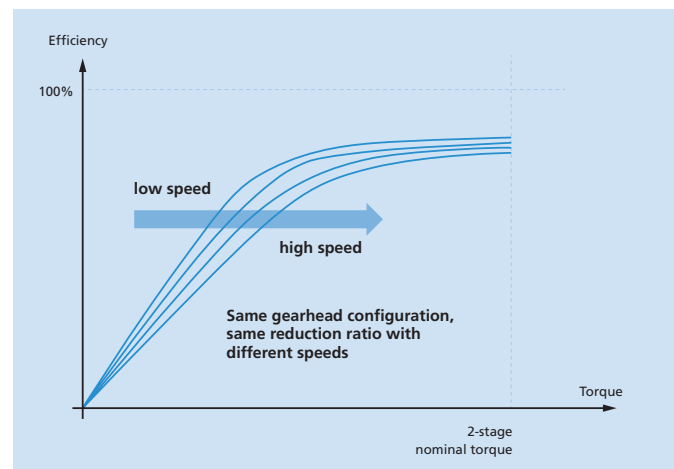
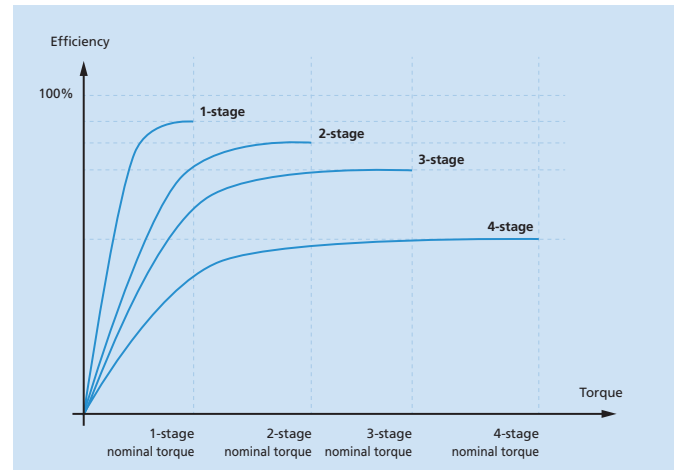

In order to achieve a good efficiency the gearhead should ideally be used at torque level above 30% of nominal torque. The primary parameter to ensure good efficiency is torque while speed affect also efficiency but a minor proportion. To provide good efficiency a gearhead should not be used at low torque and high speed.

Besides motor current consumption, the impact of efficiency is related to heat dissipation inside the gearhead which also depends on the input power transmitted by the motor. Such heat dissipation is increasing gearhead temperature and contribute to degrade lubricant over time, impacting thus service life.

Precision Gearheads

Technical Information

Motor Combinations

GPT gearhead series can be combined with a wide range of DC motors, 4-pole and 2-pole brushless motors, for smaller diameter size also combination with stepper motors are available. This gearhead series are optimized to leverage at best the torque and speed range of the different FAULHABER motor families.

Combinations with motors come assembled from the factory. Motor-gearhead combination cannot be assembled other than on the factory line.

When combining a motor with GPT gearhead series, the motor should be selected with enough performance capabilities to avoid bringing the motor at a too high steady temperature. Such high temperatures would produce extra heat transfer towards the gearhead and could degrade prematurely the lubricant, thus impacting service life of the combination unit.

To achieve long service life, a general guideline is to ensure that the motor won't exceed a temperature of 60°C to 70°C at steady state during operation. Such motor temperatures will avoid premature degradation of lubricant inside the gearhead.

Modifications and standard options

GPT gearhead series are available with a big range of standard options and modifications. Some of these options are made available to match particular requirements related to specific applications with special ambient conditions, others are made to ease the product integration inside the application system, others to enhance particular performance parameters for specific needs.

Such product options refers to:

- output shaft shape and dimensions
- ambient conditions like particular temperature range or special environmental conditions as vacuum.
- different motor cable or terminals orientation when integrating the combination unit inside the application
- other requirements related to output load fixed on the output shaft

Most options are modifying the basic product so that characteristics will differ from the performance of the standard version. This latest aspect should be considered when selecting an option and eventual questions should be addressed to your local sales representative.

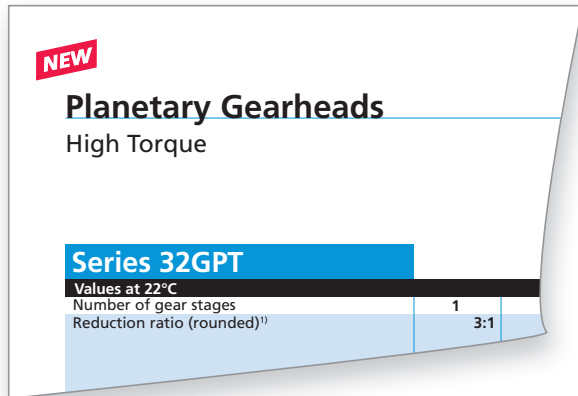

Notes on technical datasheet

Unspecified tolerances

Tolerances in accordance with ISO 2768 medium.

≤ 6	= ± 0,1 mm
≤ 30	= ± 0,2 mm
≤ 120	= ± 0,3 mm

Reduction ratio

The listed ratios are nominal values only, the exact ratio for each reduction gearhead can be calculated by means of the stage ratio applicable for each type.

Output torque

Continuous operation: The continuous torque provides the maximum possible load applied to the output shaft; exceeding this value will reduce the service life.

Intermittent operation: The intermittent torque value may be applied for a short period. It should be for short intervals only and not exceed 20% of the continuous duty cycle.

Peak torque: This torque limit represents the absolute maximum torque supported by the gearhead for unexpected events generated randomly on the output shaft load. Such peak torque cannot occur in cyclic mode or in a timely repetitive manner. This parameter is not intended to be used as a dimensioning constraints to drive any loads. Gearhead output is able to support such torque value with a non-repetitive scheme few hundreds to few thousand times during its operation without impacting service life.

Input speed

Continuous operation: The recommended maximum input speed for continuous operation serves as a guideline. It is possible to operate the gearhead at higher speeds.

However, to obtain optimum life performance in applications that require continuous operation and long life, the recommended speed should be considered.

Intermittent operation: The intermittent input speed value may be applied for a short period. It should be for short intervals only and not exceed 20% of the continuous duty cycle. Operating gearhead at speeds higher than intermittent maximum value is not recommend as it will reduce significantly service life, and in some cases it could generate early damage with abrupt stop.

Output Power

Continuous operation: The recommended maximum output power for continuous operation serves as a guideline. It is possible to operate the gearhead momentarily with higher output power for brief period. However, to obtain optimum life performance in applications that require continuous operation and long life, the recommended continuous output power should be considered.

Intermittent operation: The intermittent output power value may be applied for a short period. It should be for short intervals only and not exceed 20% of the continuous duty cycle. Operating gearhead at higher power than intermittent maximum value is not recommend as it will reduce drastically service life.

Efficiency

The maximum efficiency refers to the continuous operation mode. Such value varies depending on the number of stages and could also depend on the reduction ratio. The gearhead efficiency varies depending on the speed-torque operating point. For low torque value below 30% of nominal torque, efficiency could be significantly reduced. Efficiency varies in minor proportion with speed, at highest speed efficiency is slightly reduced.

Input inertia

Maximum input inertia can be used to determine the necessary torque required to ensure a particular acceleration of the geartrain typically for positioning applications with high dynamics. Such inertia value is referred to the gearhead input at the motor output shaft and including the motor pinion. Such value is depending on the geartrain configuration (e.g.: number of satellite gears), the number of stage and thus on the reduction ratio also. The reported value is the maximum one considering the various possible configuration of the geartrain.

Precision Gearheads

Technical Information

Torsional stiffness

Torsional stiffness represents the angular rigidity of the whole geartrain including the output shaft. This parameter is reporting the output torque necessary to twist the output shaft by one degree when the gearhead input is fixed. This is a typical measured on several samples.

Backlash

Backlash: Backlash is defined by the amount by which the width of a tooth space exceeds the width of the engaging tooth on the pitch circle. Backlash is not to be confused with elasticity or torsional stiffness of the system.

The general purpose of backlash is to prevent gears from jamming when making contact on both sides of their teeth simultaneously. A small amount of backlash is desirable to provide for lubricant space and differential expansion between gear components. The backlash is measured on the output shaft, at the last geartrain stage.

Backlash represent the angular play of the whole geartrain when rotating the gearhead output shaft with no load while the gearhead input is fixed. Such angular play consider the angle between both clockwise and counterclockwise end positions of the output shaft, without applying torque. This reported value is typical measured on several samples.

Backlash under load: The backlash under load between 2 angular positions is depending on the torque load in the CW and CCW directions for those respective positions. Such backlash is the sum of the backlash at no-load and the contribution of the torsional stiffness depending the torque values in these 2 load positions as illustrated the graph below:

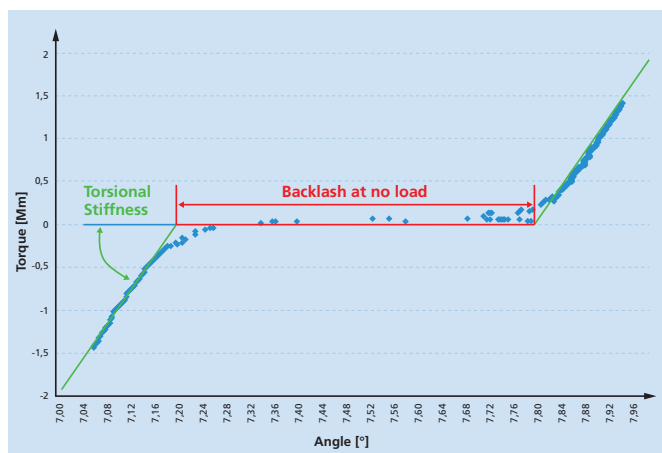

Shaft load

Radial load: The maximum output shaft load represents the maximum dynamic load (when output shaft is rotating) that can be applied radially at a particular distance from the output flange and that the gearhead ball bearing system can support without impacting the service life. In case the radial load would be applied at another distance this value should be extrapolated appropriately.

Axial load: The maximum axial load is the maximum dynamic load (when output shaft is rotating) when pressing the shaft towards the inner side of the gearhead without damaging prematurely the bearing system and without impacting service life.

Shaft press fit force

The press fit force is the maximum static force that can be axially applied to gearhead output shaft in order to mount a coupling element, for example a pulley or a pinion. This is a static force while the geartrain is stand-still and not rotating. Please note that this force does not refer to any operating conditions of the gearhead when used inside the application.

Shaft play

Radial Play: The radial play is the maximum clearance that the output shaft can move radially when measured at a specific distance from the front flange. Such radial play measure depends on the position of measurement along the shaft and on the force used for measurement. The radial play value assumes that maximum force reported in the datasheet will not exceed the maximum radial load.

Axial Play: The axial play on the gearhead output shaft is the maximum distance that the output shaft move in the axial direction when pushing the shaft towards the inner side of the gearhead. Such axial play value depends on the ball bearing system and the relative preload design. The axial play assumes that maximum axial load force reported in the datasheet is not exceeded. When pulling the shaft in the direction out from the gearhead, a minimum play is required to avoid ball bearings to jam, such play in pull direction depends on the bearing preload design.

Operating temperature range

Standard range as listed on the data sheets. Service lifetime is also influenced by the operating temperature, especially for high temperature above 70°C.

Special executions for extended temperature range available on request.

Direction of rotation, reversible

All gearheads are designed for clockwise and counter-clockwise rotation. The indication refers to the direction of rotation as seen from the shaft end, with the motor running in a clockwise direction.

Ball bearings

Ratings on load and lifetime, if not stated, are according to the information from the ball bearing manufacturers.

Length

The length *L2* without motor reported in the datasheet is the length of the stand-alone gearhead excluding any adaptation flange. The length *L1* with motor is reporting the total length of the combination including the motor, the coupling flange and the gearhead.

Linear Components

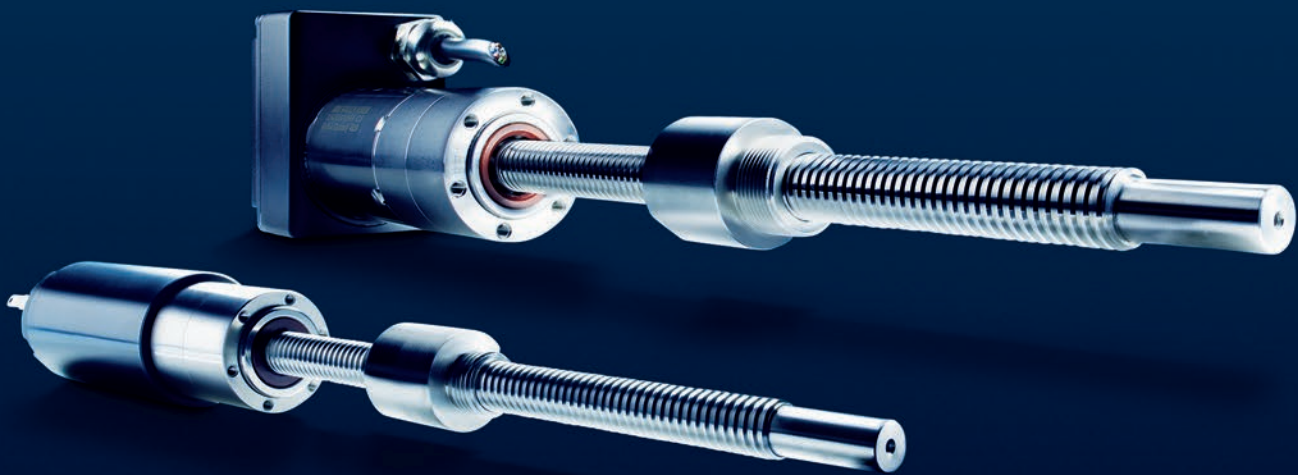

Ball Screw

Technical information

General information

Function:

Ball screws convert rotational movements into an axial movement. Ball screws, which are designed as a recirculating ball screw, have a very high level of efficiency in comparison with planetary screw drives (such as trapezoidal screws or metric screws) due to the lower rolling friction that occurs. In addition, the superior manufacturing precision enables a very low axial play, accompanied by a very high positioning accuracy.

In addition to the ball screw, the BS product series also includes both the bearing and the coupling to the motor. The duplex bearing used in this case – a pair of angular ball bearings with backlash-free mounting – enables the absorption of axial tensile and compressive forces. The high-precision pin coupling transmits the motor torque to the screw virtually backlash-free.

Mounting

A number of threaded holes are provided on the front of the housing for the purpose of attaching the motor-screw combination.

Because of the high-precision raceways and the low-backlash or backlash-free adjustment, the ball screw nut cannot compensate for radial deviations between screw axis and any additional guides of an attachment to the nut. A radial decoupling element must be provided here if necessary. This relates to deviations of the radial distance (misalignment) and angular deviations (tipping) of the guides.

In order to reduce radial forces on the bearing, it is recommended that the screw is supported by an additional bearing.

Handling

The ball raceways on the ball screws are exposed. For this reason, the screw drives have to be protected against dirt and contamination. The ball screw nut must never, either in operation or during mounting, be moved out beyond the raceway area of the ball screw.

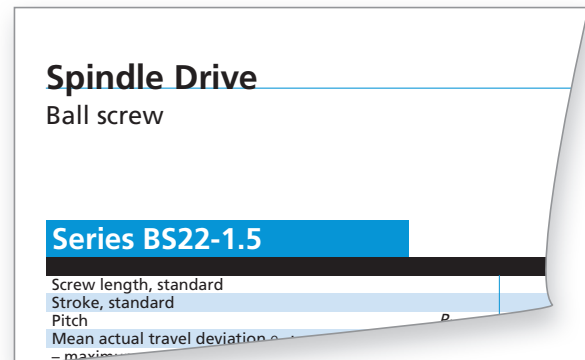

Notes on technical datasheet

Ball screw length, standard [mm]

Designates the length of the ball screw between the front of the housing and the end of the ball screw.

Stroke [mm]

Maximum path which the ball screw nut may axially travel. The metric fastening thread of the ball screw nut can protrude beyond the raceway area of the ball screw.

Pitch P_h [mm]

Axial displacement when rotating the ball screw by 360° relative to the ball screw nut.

Average actual travel deviation, max. permissible e_p [μm]

The averaged deviation of the actual travel from the ideal nominal travel is called the average actual travel deviation e_{0a} . This is limited by the value e_p over the entire travel ($e_{0a} \leq e_p$).

Tolerance of travel variation v_{up} [μm]

In parallel with the average actual travel deviation, short-wave travel variations can occur. The bandwidth, represented as a blue band in the following, is limited by the value of the tolerance of travel variation v_{up} .

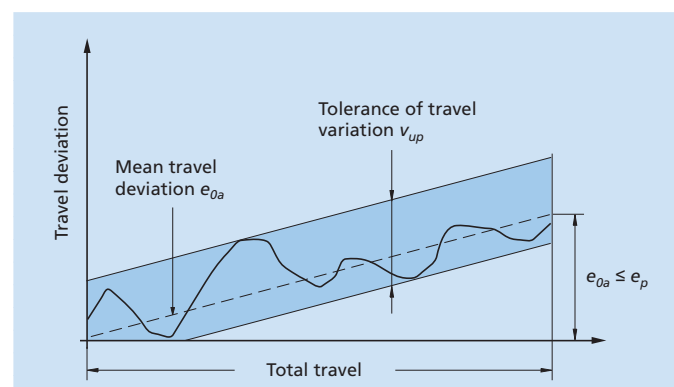

Ball Screw

Technical information

Efficiency η_{max} [%]

Describes the ratio between the power input and power output of the ball screw at axial load $F_{m\ max}$.

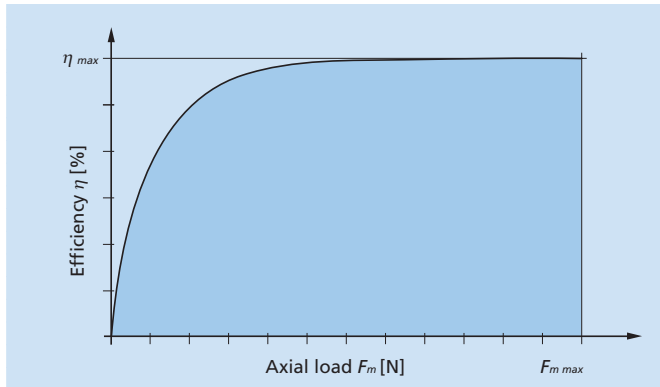

Please observe the dependence of the efficiency on the axial load, especially for small axial loads.

Operating temperature range [C°]

Designates the maximum and minimum permissible operating temperature of the ball screw.

Axial load capacity, dynamic C_{am} [N]

Parameter for calculating the theoretical service life. This corresponds to a constant axial load in a constant direction, at which a theoretical service life of 10^6 revolutions is achieved. This is based on a life expectancy of 90%.

Axial load capacity, static C_{oa} [N]

Maximum permissible axial loading of the ball screw nut. Unless specified otherwise, this is also the maximum permissible axial loading of the ball screw. To prevent exceeding of the permissible loading, the motor current must be limited if necessary.

Max. permissible shaft loading, radial $F_{rs\ max}$ [N]

Maximum permissible radial loading of the ball screw. This is dependent on the acting lever arm.

Screw nut, axial play [μ m]

Maximum axial displacement of the ball screw nut in relation to the ball screw, if these are not twisted towards each other. This is determined using an axial test force of 3.5 N.

Max. permissible nut loading, radial $F_{rn\ max}$ [N]

Maximum permissible radial loading of the ball screw nut.

Direction of rotation

Direction of rotation of the ball screw, observed from the direction of the ball screw. With a right-hand thread the clockwise direction of rotation of the drive shaft (= rotating clockwise) results in an increase in the distance between drive and ball screw nut.

Recommended values

The maximum permissible values for continuous operation in order to obtain an optimal service life are listed below. The values are mathematically independent of each other.

Continuous axial load $F_{m\ max}$ [N]

Designates the maximum recommended axial load during continuous operation.

Intermittent axial load $F_{p\ max}$ [N]

Designates the maximum permissible axial load. The motor current must be limited if necessary in order to prevent exceeding of the permissible loading.

Rotational speed, max. [min^{-1}]

Designates the maximum permissible rotational speed.

Linear speed, max. [mm/s]

Designates the maximum permissible linear speed. This results from the product of the maximum permissible rotational speed and the pitch P_h .

Calculations

Calculation of the motor drive torque

The minimum required motor drive torque can be derived as follows

$$M_{mot} = \frac{F_m \cdot P_h \cdot 100}{2\pi \cdot \eta}$$

Required motor torque	M_{mot}	[mNm]
Continuous axial load	F_m	[N]
Pitch	P_h	[mm]
Efficiency	η	[%]

Calculation of the motor drive speed

$$n_{mot} = \frac{v \cdot 60}{P_h}$$

Required motor speed	n_{mot}	[min ⁻¹]
Linear speed	v	[mm/s]
Pitch	P_h	[mm]

Calculation of the theoretical lifetime

The service life depends on the following factors:

- Axial load
- Linear speed
- Operating conditions
- Environment and installation in other systems

As a very large number of parameters come into play in any application, a precise service life definition is not possible.

As a non-binding reference value a theoretical service life can be calculated on the basis of standard ISO 3408:

The theoretical service life is generally defined by the number of revolutions. Alternatively, it can also be specified in hours or as travel. It is based on a life expectancy of 90%.

The theoretical service life is calculated as follows:

$$L_{rev} = \left(\frac{C_{am}}{F_m} \right)^3 \cdot 10^6$$

$$L_h = \frac{L_{rev}}{n_m \cdot 60}$$

$$L_s = P_h \cdot \left(\frac{C_{am}}{F_m} \right)^3 \cdot 10^3$$

Service life in revolutions	L_{rev}	[rev]
Service life in hours	L_h	[h]
Service life in meters	L_s	[m]
Dynamic axial load capacity	C_{am}	[N]
Continuous axial load	F_m	[N]
Average motor speed	n_m	[min ⁻¹]
Pitch	P_h	[mm]

Ball Screw

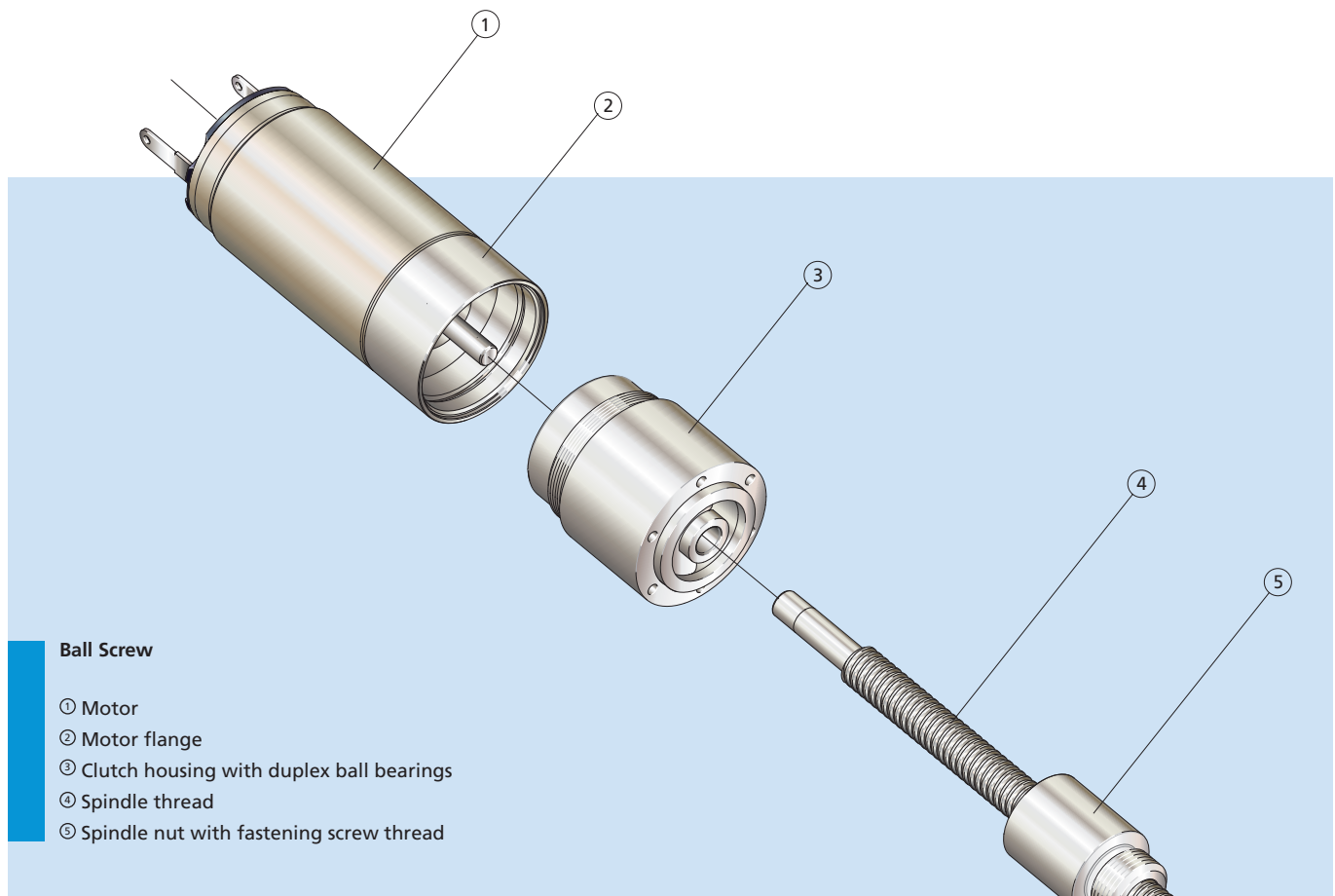

Features

Thanks to their high-precision mechanical design, FAULHABER ball screws are ideally suited for positioning tasks requiring a high degree of accuracy. Combinations with DC-Micromotors with high-resolution encoders, integrated Motion Controllers or Stepper Motors represent a superior system solution for the most demanding applications in optical systems, special machine construction, automation or medical technology.

Compact design in conjunction with numerous modification options translates into the perfect drive solution for a wide range of applications.

Benefits

- Long service life
- High efficiency
- Variable length
- Customized versions with special lubrication for extended application areas
- High positioning accuracy thanks to considerably reduced play

Product code



BS	Ball screw
22	Coupling diameter [mm]
1.5	Pitch [mm]

BS 22-1.5

Lead Screws and Options

Technical Information

Lead screws parameters

Resolution (travel/step)

A lead screw combined with a PRECstep® stepper motor can achieve a positioning with a resolution of 10µm.

The resolution of the position depends on the pitch and number of steps per revolution:

$$P = \frac{P_h}{n}$$

With P_h the pitch of the screw and n the number of steps per revolution of the motor.

Driving the motor with half-stepping or microstepping will improve the resolution up to a certain extent.

The resolution must be balanced with another parameter: the precision.

Precision

The motor step angle accuracy is one parameter, together with the axial play between the nut and the lead screw, influencing the precision of the linear displacement. It varies between ± 3 and $\pm 10\%$ of a full step angle depending on the motor model (see line 9 on motor datasheet) and remains the same with microstepping. It is however not cumulative.

Axial play

An axial play up to 30µm is measured with optional nuts offered in this catalogue. However, it is possible to negate the axial play by implementing a preloading system in the design of the application (for instance with a spring mechanism).

The "zero" axial play between the lead screw and motor housing is ensured thanks to a preload of the motor ball bearings (in standard configuration: spring washer on rear ball bearing). An axial play up to 0.2 mm will occur if the axial load on the lead screw exceeds the ball bearing preload.

This does not cause any damage to the motor and is reversible. This occurs only while pulling on the shaft. On request, customization can overcome this limitation.

To avoid irreversibly damaging the motor, the maximum axial load should always remain under the maximal push force the motor can generate with a mounted lead screw.

Lead Screw

Linear actuation for positioning tasks

Series M2 x 0,2 x L1

Ordering information	L1 (mm) =
Order code (no bearing tip)	
Order code (with bearing tip)	
Nominal diameter	2.0
Pitch	
Material	

Backdriving

Backdriving the motors while applying an axial load on the lead screws is impossible. The pitch vs. diameter ratio does not allow it.

Force vs speed curves

The force that a linear system can provide depends on the type of screw and stepper motor selected. Torque vs speed curves for each solution are provided in this catalogue. Those curves do already consider a 40% safety factor on the motor torque as well as a conservative lead screw efficiency in the calculation.

Tip for bearings

Ideally, the application should handle radial loads and the lead screw only axial loads. If it is not the case, it is possible to get lead screws with a tip suitable for bearing at its front end in order to handle radial loads. With this configuration, a special care to the alignment of the motor and bearing must be paid to not deteriorate the thrust force achievable. Optional mating ball bearings are available in the dedicated datasheet for options.

Nut

Optional nuts offered in this catalogue are shaped with a flat in order to prevent its rotations in the application. Alternatively, tapped holes on the application are a convenient solution since metric taps are readily available.

Lead Screws and Options

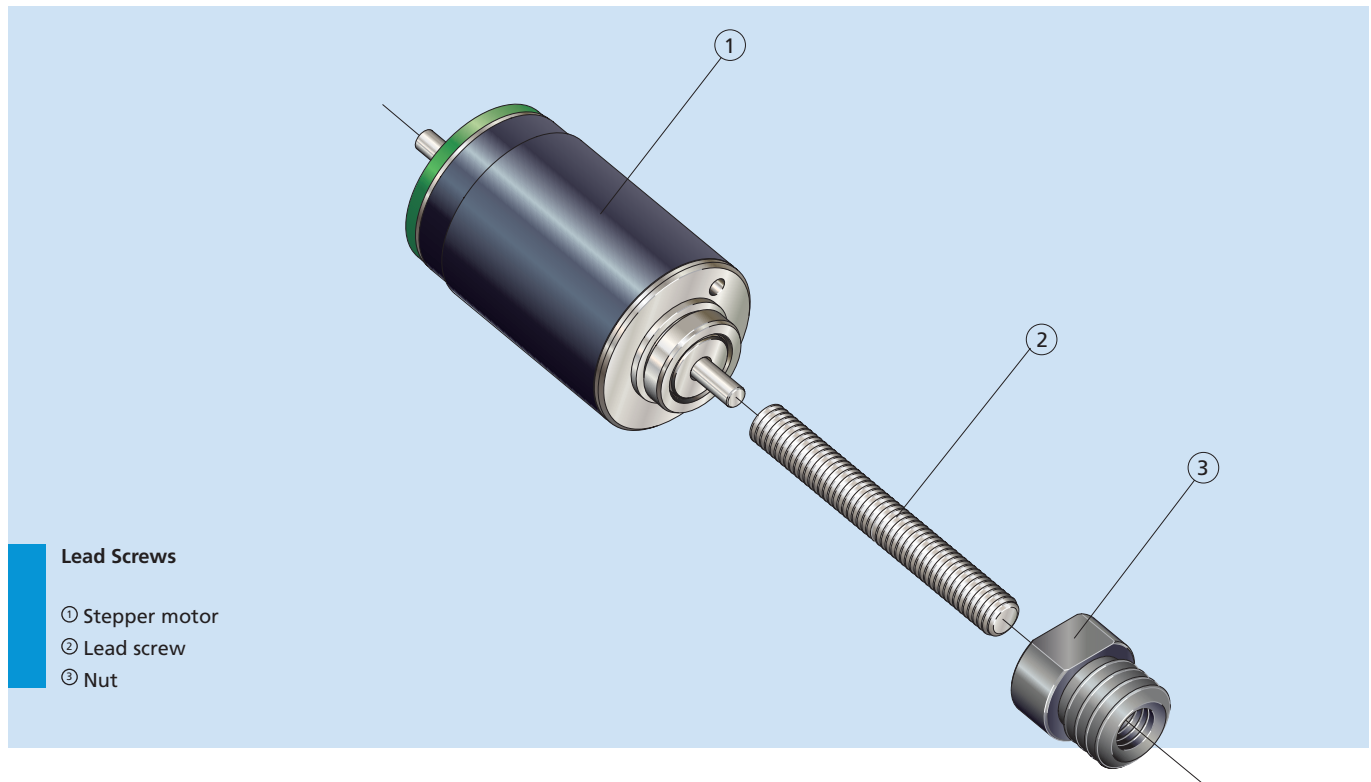

Lead Screws

- ① Stepper motor
- ② Lead screw
- ③ Nut

Features

Stepper motors can be used for more than just a rotation. When combined with lead screws, they provide a high accuracy linear positioning system that provides the benefits of a stepper (open loop control, long life, high torque density, etc.).

The lead screws available on stepper motors are all based on metric dimensions (M1.2 up to M3) and specifically designed to be assembled with PRECstep® stepper motors. The technique used to produce the thread ensures a very high precision and consistency of quality. A large choice of standard lengths is available from stock and customization is possible on request.

Such a combination is ideal for any application such as requiring accurate linear movement or lens adjustment (zoom, focus), microscope stages or medical syringes.

Benefits

- Cost effective positioning drive without encoder
- High accuracy
- Wide range of lead screws available
- Short lead time for standard length
- Flexibility offered by optional nuts and ball bearings
- Custom length on request

Product code

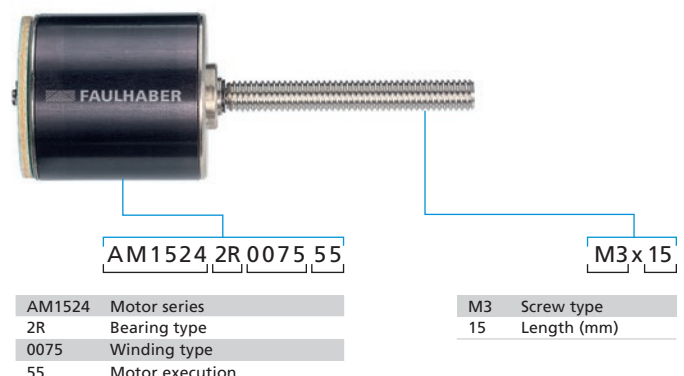

AM1524	Motor series
2R	Bearing type
0075	Winding type
55	Motor execution

M3	Screw type
15	Length (mm)

Notes

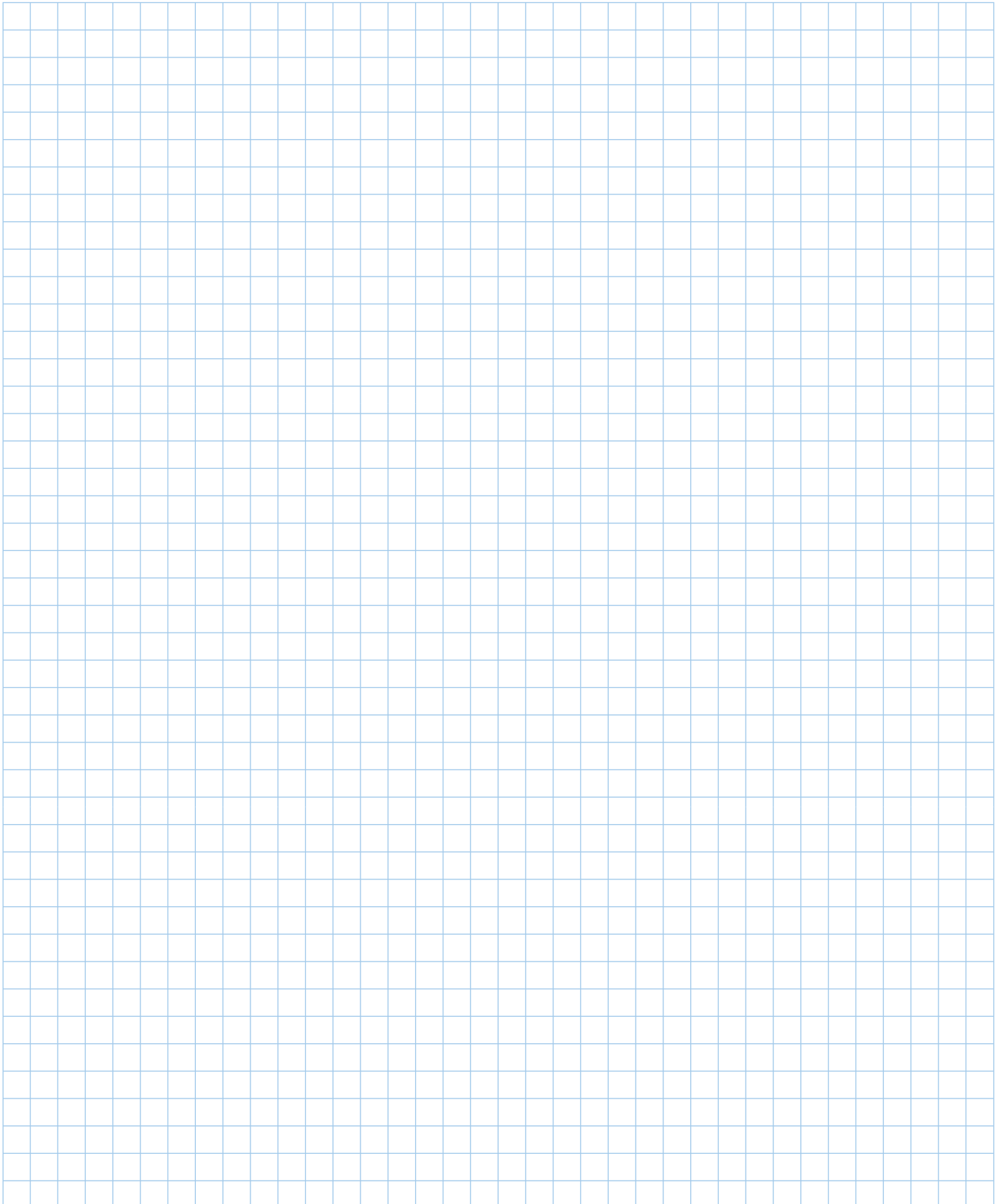

Encoders



Encoders

Technical Information

General information

FAULHABER Motors are available with a variety of sensors and encoders for providing solutions to a wide range of drive applications – from speed control to high-precision positioning.

Sensors and encoders

FAULHABER Motors are offered in combination with sensors and encoders. An encoder is a sensor for angle measurement that is usually used for speed or position control. The term sensor refers to digital or analog Hall sensor which, in the FAULHABER Brushless DC-Motors, are usually mounted directly on the motor circuit board. Digital Hall sensors are used primarily for the commutation of the Brushless DC-Motors and for simple speed control. Almost all FAULHABER Brushless DC-Motors are equipped standard with three integrated digital Hall sensors.

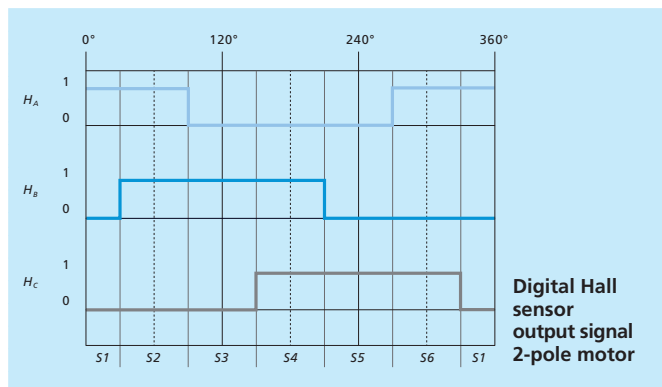

In addition, analog Hall sensors are generally available as an option.

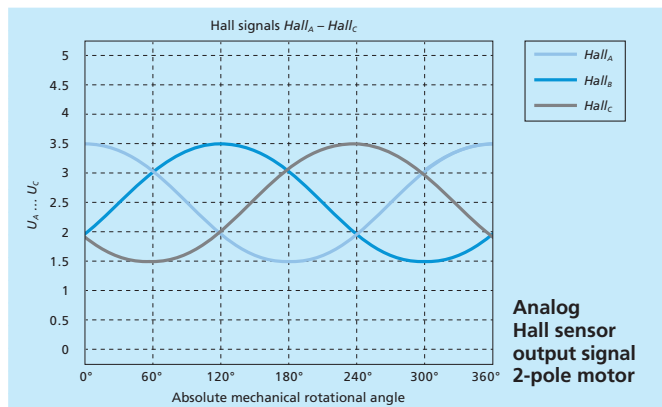

Due to the higher resolution, the analog Hall sensors can also be used for precise speed or position control, making them an especially economical, lightweight and compact alternative to encoders. The option for analog Hall sensors can be found directly in the data sheets of the motors

under “Controller combinations”. If this option is selected, no encoder is needed. The space and cost advantages make analog Hall sensors the preferred solution for most positioning applications with Brushless DC-Motors. When selecting this option, it is recommended that the sensors be operated with FAULHABER Controllers, which are perfectly designed for the analog Hall signals.

Functionality

Measurement principle

The FAULHABER Sensors and Encoders are based on magnetic or optical measurement principles.

Magnetic encoders are especially insensitive to dust, humidity and thermal and mechanical shock. In magnetic encoders, sensors are used that determine the changes of the magnetic field. The magnetic field is changed by the movement of a magnetic object. This can be the magnet of the motor or an additional sensor magnet with a defined measuring element that is secured to the shaft of the motor. With encoders, an additional sensor magnet is usually necessary.

In the case of integrated digital or analog Hall sensors, the movement of the rotor magnet of the motor can be measured directly. With the integrated Hall sensors, an additional sensor magnet is therefore normally not necessary.

Optical encoders are characterised by a very high position accuracy and repeatability and a very high signal quality due to the precise measuring element. Furthermore, they are insensitive to magnetic interference. In optical encoders, a code disc with a measuring element is used that is attached to the shaft of the motor. A distinction is made between reflective and transmissive optical encoders. With reflective encoders, the light from an LED is reflected back to the code disc by a reflective surface and collected by photodetectors. Reflective optical encoders are especially compact since the LED, the photodetectors and the electronics can be mounted on the same circuit board or even on the same chip. FAULHABER therefore primarily uses reflective optical encoders. With transmissive encoders, the light from the LED passes through slits in the code disc and is collected by photodetectors on the other side of the code disc.

Encoders

Technical Information

Moving Element

Depending on the measurement principle and dimensional constraints different moving elements are applied in different types of FAULHABER Encoders. The moving element has a significant impact on the accuracy and resolution of the encoder. In general, the higher the physical (native) resolution of the moving element, the higher the resolution and accuracy of the encoder as a whole.

In magnetic encoders, simple, two-pole sensor magnets and magnetic rings are used. The magnetic rings have several signal periods per revolution through the use of a special tooth structure or targeted magnetisation. The number of signal periods corresponds to the physical resolution of the magnetic rings.

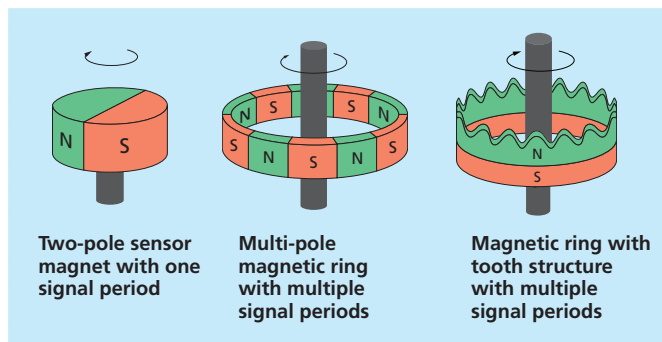

In optical encoders, moving elements in the form of code discs are used. With reflective encoders, these consist of a series of surfaces that alternately reflect or absorb light. With transmissive encoders, the code discs consist of a series of bars and slits. The number of reflective surfaces or slits corresponds to the physical resolution. In general, optical encoders can have a significantly higher native resolution than magnetic encoders.

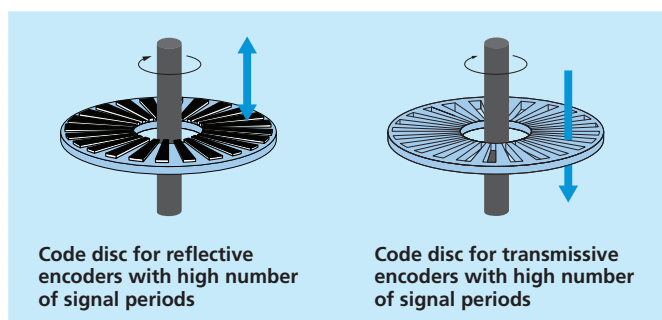

Signal processing and interpolation

In addition to the sensors for signal acquisition, the FAULHABER Encoders also include electronic components for signal processing. These process the signals from the sensors and generate the standardised output signals of the encoders. In many cases, the signals are also interpolated, i.e., multiple signal periods are generated by interpolating a single physically measured signal period. The physical resolution of the measuring element can thereby be increased many times over.

Characteristic encoder features

The quality of an encoder is largely determined by the resolution and the accuracy.

Resolution

The resolution is the number of edges or steps that an encoder produces within a revolution. The resolution is determined from the physical resolution of the moving element and the interpolation of the physical signal via the electronics. Due to the large amount of information that is made available per motor revolution, a high resolution offers various advantages for a drive system:

- Smoother speed control and lower audible noise
- Operation at lower speed

A high resolution in excess of 4 000 edges or steps is relevant if the motor is used as a direct drive for positioning or if the motor is operated at very low speeds.

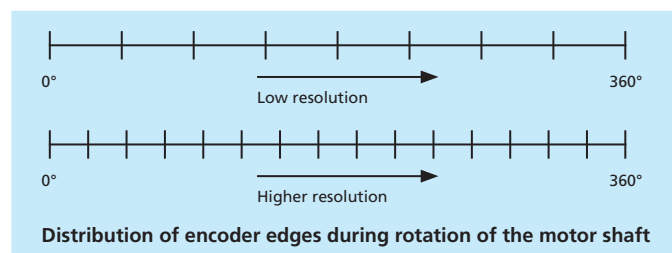

Accuracy

Independent of the resolution, the accuracy also plays an important role. The accuracy is determined by the physical resolution of the moving element and the precision with which not only the moving element and the encoder are manufactured, but the entire drive system as well. If an encoder has a high accuracy, it always transmits the signals at the same spacing for each and every motor revolution and thus has a high signal quality.

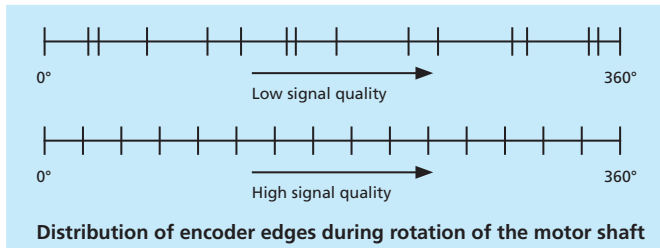

The most important parameter for the signal quality of the FAULHABER Encoders is the phase shift tolerance ($\Delta\Phi$). If the phase shift tolerance is low, the encoder transmits uniform signals. While FAULHABER magnetic encoders have a high signal quality with a phase shift tolerance of approximately 45° , FAULHABER optical encoders demonstrate an especially high signal quality with a phase shift tolerance of approximately 20° . Optical encoders are generally more accurate than magnetic encoders.

Detailed information for the calculation of the phase shift tolerance can be found in the chapter “Notes on technical data sheet” under the heading “phase shift”.

A high accuracy or a high signal quality has multiple advantages for a drive system:

- Exact determination of the position and, thus, accurate positioning
- Smoother speed control and lower audible noise

A high accuracy is relevant above all if the motor is used as a direct drive and exact positioning is necessary.

To position a drive system precisely, a highly accurate encoder is not enough. Tolerances in the entire drive system must be taken into account, such as the concentricity tolerance of the motor shaft. The accuracy and the phase shift tolerance of the FAULHABER Encoders is therefore determined in combination with the FAULHABER Motors. The specified position accuracy and repeatability is the system accuracy that a FAULHABER Motor-Encoder combination actually achieves in an application.

Output signal

Incremental encoder

Incremental encoders transmit a specific number of uniformly distributed pulses per revolution. All FAULHABER Incremental Encoders have at least two channels: *A* and *B*. Both channels supply a square wave signal, shifted by 90° with respect to one another, i.e., one quarter cycle *C*. Through the shift of the pulses, the direction of rotation of the motor can be determined.

The highest angular resolution of incremental encoders is not determined by the number of pulses per revolution but rather the total number of signal edges.

For encoders with at least two channels, the state of channel *A* or channel *B* changes every 90° due to the phase offset. The edges, i.e., the state change of the encoder channels, are evaluated for determining the position. Because four edges occur per pulse, the resolution of the FAULHABER Incremental Encoders is four times their pulse number. Thus, an encoder with 10 000 pulses per revolution, for example, has 40 000 edges per revolution, which corresponds to a very high angular resolution of $360^\circ/40\,000 = 0,009^\circ$.

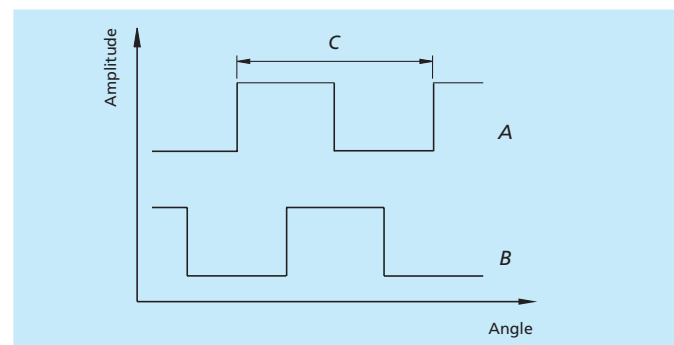

An incremental encoder does not measure absolute positions, but rather relative positions. Incremental encoders determine a position relative to another reference position. For this purpose, the signal edges must be counted forward or backward by the motor control using a square counter according to their edge sequence. This position value is lost if the power supply is interrupted. A positioning system must therefore move to a defined reference position during commissioning or after a power interruption to initialise the position counter (homing). For the determination of the reference position, an external additional sensor, such as a reference switch or limit switch, is usually used.

To determine the reference position with an especially high level of accuracy, the FAULHABER 3 Channel Encoders have an additional channel – the index. Here, a single index pulse is generated once per revolution. External reference switches or limit switches can have a comparably high position error due to environmental influences and can sometimes trigger a little earlier, sometimes a little later. To nevertheless accurately determine the reference position, the drive system can move back after the limit switch until the first signal edge of the index pulse occurs. This point can then be used as an exact reference position.

The index pulse has a width of 90° and always occurs at defined states of channels *A* and *B*. For longer travel distances and multiple revolutions of the encoder, the index pulse can also be used to verify the counted number of edges.

Encoders

Technical Information

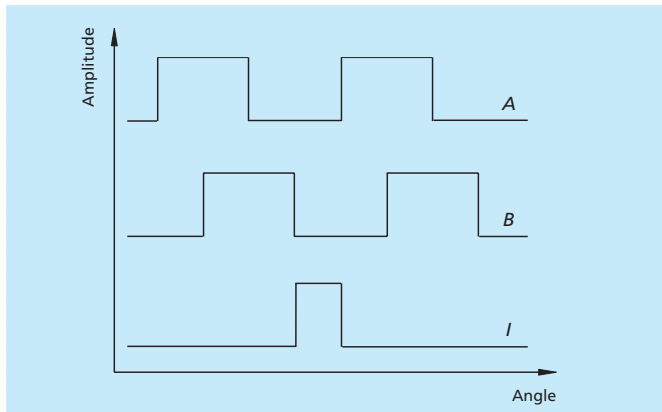

Absolute encoder

Unlike the incremental encoder, an absolute encoder determines absolute positions, not relative positions. After switching on the absolute encoder, an absolute return value is available for each position of the motor shaft. A distinction is made between single turn and multi turn encoders. The FAULHABER Absolute Encoders are single turn encoders.

With the single turn encoders, each position of the motor shaft corresponds to a specific return value. After a complete revolution of the motor shaft, the signals repeat. Thus, the single turn encoder supplies no absolute information about the number of completed revolutions. Positioning over more than one revolution is, however, still possible with the single turn encoder. Like with the incremental encoder, this is performed by counting the number of revolutions forward or backward using a counter on the motor control. For travel distances greater than one motor revolution, referencing is therefore necessary after a power interruption. No referencing is necessary for travel distances of less than one motor revolution.

Unlike single turn encoders, multi turn encoders also capture the number of travelled revolutions by means of an additional sensor and an electronic memory element or via a gearhead. Thus, multi turn encoders supply an absolute return value over multiple revolutions of the motor shaft within a defined maximum amount of revolutions that can be captured by the electronic memory element or the gearhead. Referencing is generally not necessary if the maximum amount of revolutions is not exceeded.

The analog Hall sensors, which are mounted directly in the FAULHABER Brushless DC-Motors as an option, supply absolute return values within one revolution of the motor shaft in combination with the motors with 2-pole technology and absolute return values within half of a revolution of the motor shaft in combination with motors with 4-pole technology. When using the analog Hall sensors, a

reference motion is, therefore, not necessary if positioning within one or one half revolution of the motor shaft.

The resolution of an absolute encoder is defined via the number of steps per revolution and is specified in bits. Absolute encoders generate a serial code from multiple bits. The FAULHABER Absolute Encoders support the SSI Interface with BISS-C Protocol. BISS-C supports communication with clock speeds of up to 2 MHz. Here, the absolute position value (DATA) is transferred in synch with a cycle (CLK) specified by the controller.

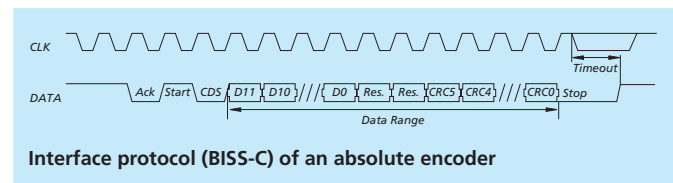

Line Driver

Some of the FAULHABER Encoders are equipped with a Line Driver. The Line Driver generates an additional differential signal for all channels. With an incremental encoder with three channels, A , B , I and \bar{A} , \bar{B} and \bar{I} are thus available. With an absolute encoder, the inverted signals \overline{CLK} and \overline{DATA} are available in addition to CLK and $DATA$. Electromagnetic interference can thereby be eliminated during signal transmission. Especially if the encoder signals must be transmitted over long distances of 5 m and more and for position control, the use of a Line Driver is therefore recommended.

On the control side, these differential signals must be combined again with a receiver module. The actually achievable line length is dependent on the ambient conditions and the type of analysis. Ideally, the differential signals are twisted pairs as well as shielded against the motor phases to allow the coupled interference at the end of the line to be decoded as error-free as possible. For longer line lengths, one may wish to consider buffering the encoder voltage supply at the end of the line on the encoder side to ensure a stable voltage supply. Furthermore, a line terminator with characteristic impedance (100 ... 120 Ω) may be useful with longer line lengths.

This must be tested in the given application. The Line Drivers from FAULHABER are TIA-422 compatible. TIA-422, also known as EIA-422 or RS-422, is an interface standard for cable-based differential, serial data transfer.

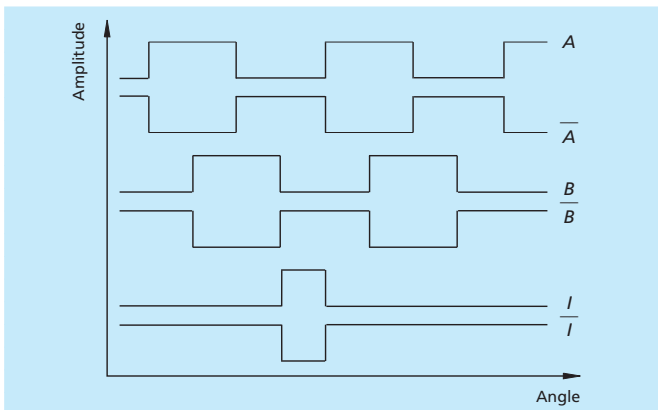

CMOS and TTL

The FAULHABER Encoders are normally compatible with the CMOS and TTL standard. This means that the “low” logic state is typically at 0V and the “high” logic state at 5V. It is important to note that the tolerances indicated in the controller specification must be observed.

Integrated solutions

Many FAULHABER Encoders are highly integrated into the existing geometry of the motor. By integrating the solutions in the motor, they are especially lightweight, compact and economical.

For the Brushless DC-Motors, these include the integrated digital and analog Hall sensors and encoders IEM3-1024 and AESM-4096. The outer dimensions of the motors are not affected by these solutions.

For the DC-Micromotors of the FAULHABER SR series, the following integrated encoders are available, which lengthen the motors by just 1,4 – 1,7 mm: IE2-16, IE2-400, IE2-1024, IEH2-4096 and IEH3-4096.

In combination with the Flat DC-Micromotors, the FAULHABER SR-Flat series includes integrated encoders that lengthen the motors by just 2,3 mm: IE2-8 and IE2-16.

Encoders

magnetic Encoder, digital outputs,
2 channels, 16 - 4096 lines per revolution

Series IEH2-4096

Lines per revolution	N	16
Frequency range, up to ¹⁾	f	5
Signal output, square wave		2
Supply voltage	U_{DD}	4.5
Current consumption, typical ²⁾		
Output current, max. ³⁾		

Notes on technical data sheet

Lines per revolution (N)

Specifies how many pulses are generated at the incremental encoder outputs per channel on each motor shaft revolution. Through the phase offset of encoder channels A and B, four edges are available per line. Thus, the resolution of the incremental encoder is four times the number of pulses. If, for example, an encoder has 1 024 lines per revolution, the resolution is 4 096 edges per revolution.

Steps per revolution

The value for “steps per revolution” specifies the number of position values per motor shaft revolution. The value is generally used with absolute encoders and corresponds to the resolution or number of edges for incremental encoders.

Resolution

Number of binary bits of the output signal. The steps per revolution of an absolute or incremental encoder correspond to the resolution of $2^{\text{number of bits}}$.

Frequency range, up to (f)

Indicates the maximum encoder frequency. This is the maximum frequency at which the encoder electronics can switch back and forth between the low and high signal level. The maximum achievable operating speed (n) for the encoder can be derived from this value and the pulse number (N). If this frequency range and the resulting speed are exceeded, the result may be the transmission of incorrect data or the premature failure of the encoder. For very high-speed applications, it may be necessary to select a correspondingly low pulse number.

$$n = \frac{60 \cdot f}{N}$$

Encoders

Technical Information

Signal output

With incremental encoders, square wave signals are output. 2 channel encoders have two channels: *A* and *B*. 3 channel encoders have an additional index channel.

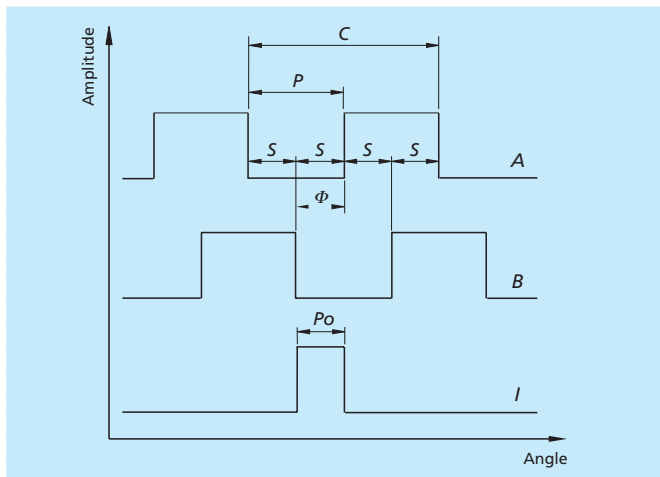

With absolute encoders, a digital word is output. FAULHABER Encoders use a SSI Interface with BISS-C Protocol. SSI is an interface for absolute encoders with which absolute position information is made available via serial data transfer.

Supply voltage (U_{DD})

Defines the range of supply voltage necessary for the encoder to function properly. To avoid damaging the encoder, this range must always be adhered to.

Current consumption (I_{DD})

Indicates the current consumption of the encoder at the given operating voltage. Normally, typical and partial maximum values are specified.

Output current, max. (I_{OUT})

Indicates the maximum allowable output current at the signal outputs. If necessary, this value should be aligned with the controller that is used.

Pulse width (P)

Width of the output pulse (in °e) of encoder channels *A* and *B*. It is ideally 180 °e.

Index pulse width (P_0)

The index pulse width specifies the width of the index pulse (in °e) and is ideally 90 °e.

The index pulse width error (ΔP_0) is the deviation from the ideal value of 90 °e.

Permissible deviation ΔP_0 :

$$\Delta P_0 = \left| 90^\circ - \frac{P_0}{P} * 180^\circ \right|$$

Phase shift, channel *A* to *B* (Φ)

The phase shift (in °e) in between output signals *A* and *B* is referred to as phase shift and is ideally 90 °e.

The phase shift tolerance ($\Delta\Phi$) is the deviation of two successive edges at outputs *A* and *B* from the ideal value of 90 °e.

Permissible deviation $\Delta\Phi$:

$$\Delta\Phi = \left| 90^\circ - \frac{\Phi}{P} * 180^\circ \right|$$

Logic state width (S)

Distance of two adjacent edges (in °e) between the two channels *A* and *B*. There are four logic state widths (S) per cycle. Ideally, a logic state width is 90 °e.

Cycle (C)

The duration of a total period (in °e) on channel *A* or *B*. Normally, a cycle is 360 °e.

Signal rise/fall time, max. (tr/tf)

Maximum time for changing from the lower to the higher signal level or vice versa. This describes the edge steepness of the encoder signals. C_{LOAD} specifies the maximum permissible load of the signal line at which the edge steepness is still reached.

Clock frequency, max. (CLK)

Maximal permissible clock frequency for reading the BISS-C Protocol.

Input - low / high level (CLK)

The level of the CLK input signal must lie in the specified value range in order to ensure reliable signal detection.

Setup time after power on, max.

Maximum time to availability of the output signals, as of when supply voltage is applied.

Timeout

Refers to the time after which communication is terminated by the encoder, when the master is no longer transmitting a clock rate.

Inertia of sensor magnet / code disc (J)

Indicates the amount by which the rotor inertia of the motor is increased by the sensor magnet or the code disc.

Operating temperature range

Indicates the minimum and maximum permissible operating temperature for encoder operation.

Accuracy

Indicates the average position error of the encoder in mechanical degrees ($^{\circ}m$). This describes the extent to which the current position of the encoder can deviate from the target position.

Repeatability

Indicates the average repeatability error of the encoder in mechanical degrees ($^{\circ}m$). This describes the average deviation of multiple position values for the encoder when positioning at the same position multiple times. Repeatability shows how precisely a certain position can be reached when repeatedly moving to the same position.

Hysteresis

Indicates the dead angle during a change in direction in which no information related to the position is output.

Edge spacing, min.

The minimum spacing between two successive edges of channels A and B . For a reliable evaluation of the square wave signal, a controller that is able to detect this minimum edge spacing is required. If no information on the minimum edge spacing is available, this can also be determined as an approximate value.

$$T_{min} = \frac{1}{f \cdot 4} \cdot \left(1 - \frac{\Delta\Phi}{90^{\circ}}\right)$$

Mass

The typical mass of the encoder, including housing and adapter flange with standard cable without connector.

Encoders

Technical Information

How to select an appropriate sensor

This chapter describes how a suitable sensor is selected for FAULHABER Motors. Which sensors can be used depends primarily on the selected motor technology. A distinction is to be made between:

- DC-Motors
- Brushless DC-Motors
- Stepper Motors
- Linear DC-Servomotors

Depending on the motor technology, the sensor is necessary not only for speed or position control, but also for the commutation of the motors.

	Commutation	Speed control	Position control
DC-Motors			
Sensors		■ encoders	■ encoders
Without sensors	■ mechanical	■ back-EMF	
Brushless DC-Motors			
Sensors	Block commutation: ■ integrated digital Hall sensors Sinus commutation: ■ integrated analog Hall sensors ■ encoders	■ integrated digital Hall sensors ■ integrated analog Hall sensors ■ encoders	■ integrated analog Hall sensor ■ encoders
Without sensors	Block commutation: ■ back-EMF	■ back-EMF	
Stepper Motors			
Sensors		■ encoders	■ encoders
Without sensors	■ stepper mode	■ stepper mode	■ stepper mode
Linear DC-Servomotors			
Sensors	■ integrated analog Hall sensors		■ integrated analog Hall sensors

DC-Motors

Commutation

The commutation of DC-Motors with precious metal or graphite brushes is mechanical and therefore requires neither a sensor nor a motor control.

Speed and position control

For some applications, the DC-Motors are operated without a sensor and without a controller. In these cases, a specific voltage is applied to the motors at which a specific speed is produced when operated at a constant load.

A controller is necessary in order to regulate the speed. Simple speed control is possible by measuring the back electromotive force (EMF). For precise speed control, an encoder is necessary. For position control, an encoder is absolutely required.

For DC-Motors, a large selection of incremental encoders is available.

Brushless DC-Motors

Commutation

The Brushless DC-Motors are electronically commutated. For their operation, a controller is therefore always necessary.

Most of the FAULHABER Brushless DC-Motors are equipped with three digital, integrated Hall sensors that determine the position of the motor shaft and supply a commutation signal.

The exception here are motors for simple speed applications, which can be commutated with the help of the back electromotive force (EMF). Here, the controller evaluates the zero crossing of the back-EMF and then commutates the motor after a speed-dependent delay. The zero crossing of the back-EMF cannot be evaluated while the motor is at a standstill and, thus, the position of the rotor cannot be detected. When starting, it is therefore possible that the motor first moves in the wrong direction.

If digital Hall sensors are selected or in sensorless operation with back-EMF, the Brushless DC-Motors are block commutated. With block commutation, the voltage characteristics of the three 120° offset windings are block shaped. The windings are abruptly switched every 60°. The FAULHABER Speed Controllers use this commutation form.

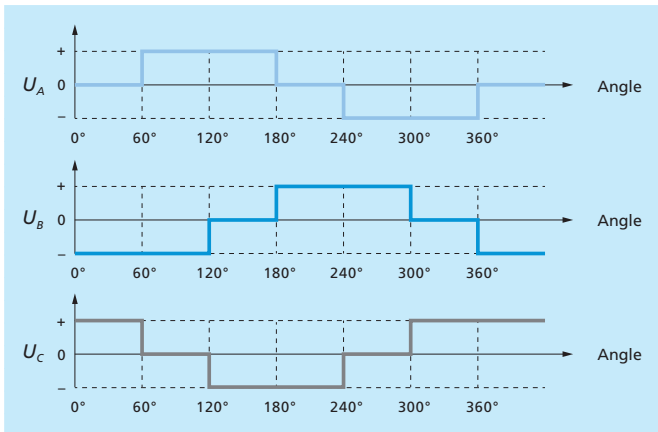

A better running smoothness with a lower torque ripple is achieved through sinus commutation.

With sinus commutation, the phase voltages have a sinusoidal characteristic. The FAULHABER Motion Controllers use this commutation form as standard. For sinus commutation, analog Hall sensors or encoders are required.

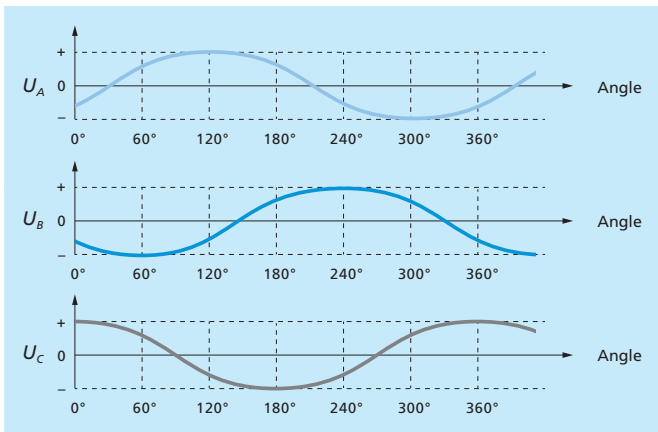

Speed and position control

For speed control, digital Hall sensors are generally used. The back electromotive force is only suitable for simple speed control at higher speeds. Analog Hall sensors or an encoder are necessary if the drive system is operated at low speeds or a very high running smoothness is required.

For position control, encoders or integrated Hall sensors are needed. Almost all FAULHABER Brushless DC-Motors are offered with integrated analog Hall sensors as an option. For most applications, operation with the analog Hall sensors is recommended. Encoders are needed if the application requires a higher resolution or accuracy or if the motor is operated at very low speeds.

For the Brushless DC-Motors, a large selection of incremental and absolute encoders is available.

Stepper Motors

The control of stepper motors in full step, half step and micro step operation enables exact speed and position control in an open control loop. As a result, sensors are not generally needed in the application – a decisive cost advantage of stepper motors. A closed control loop is, however, often required during development for verifying the function or for minimizing power consumption and motor heating. The FAULHABER product range includes magnetic (IE3) and optical encoders (PE22) compatible with the stepper motor series. Other combinations of stepper motors with encoders are possible on request.

Linear DC-Servomotors

The linear DC-Servomotors are equipped with analog Hall sensors. By integrating sensors in the motor, this solution is very compact, lightweight and economical. As a result, an additional encoder is not necessary.

Encoders

Optical Encoders

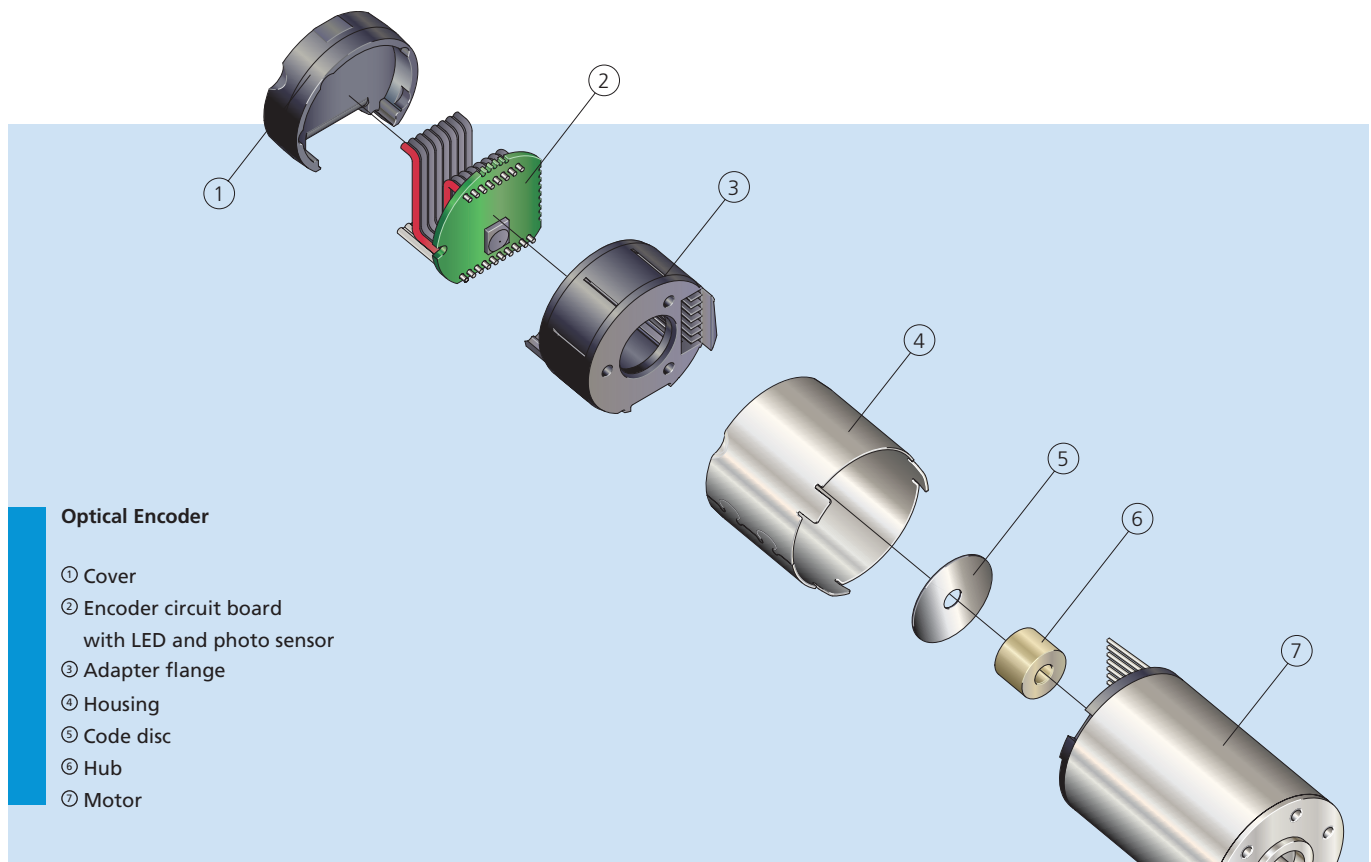

Optical Encoder

- ① Cover
- ② Encoder circuit board
with LED and photo sensor
- ③ Adapter flange
- ④ Housing
- ⑤ Code disc
- ⑥ Hub
- ⑦ Motor

Function

Encoders of the IER3-10000 (L) series consist of a high-resolution code disc that is attached to the motor shaft, a light source and a photo sensor with interpolator and driver stages. The light from the light source is reflected or absorbed by the code disc. The reflected light is collected by the photo sensor and the signal processed into a high-resolution encoder signal. With this, two square wave signals that are phase-shifted by 90 °e, as well as an index signal to display output shaft rotation, are available at the outputs. A Line Driver is also available as an option.

The high-precision optical encoders are ideally suited for position control.

Features and benefits

- Very high resolution of up to 40 000 edges per revolution (corresponds to a 0,009° angle resolution)
- Very high position accuracy, repeatability and high signal quality
- Various resolutions available as standard feature
- Insensitive to magnetic interference

Product code



IER	encoder series
3	3 channel
6800	lines per revolution
L	with integrated Line Driver

IER 3 - 6800 L

Encoders

Magnetic Encoders

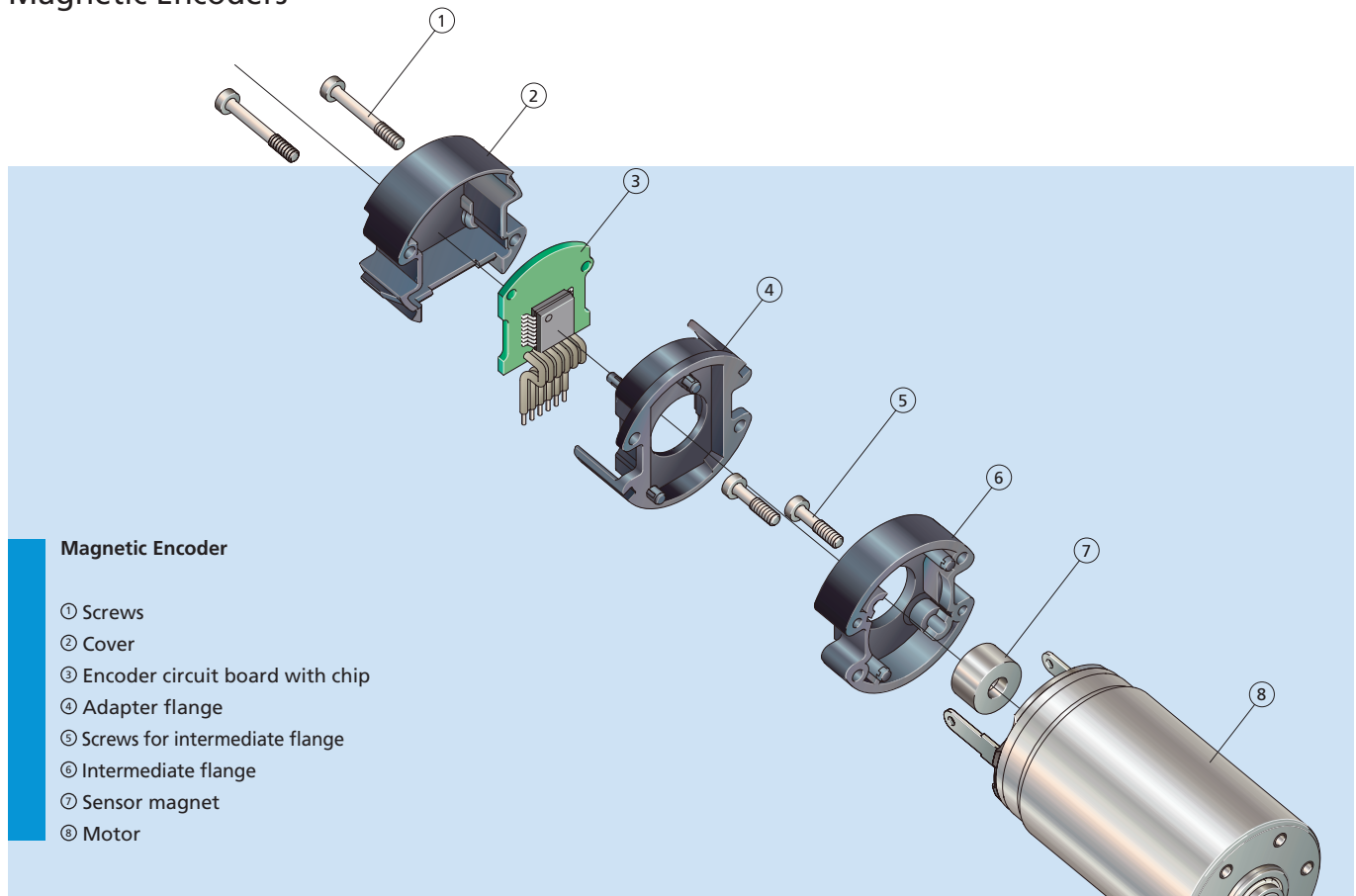

Function

Encoders of the IE3-1024 (L) series consist of a diametrically magnetized, two-pole sensor magnet which is fastened to the motor shaft. A special angle sensor for detecting the motor shaft position is positioned in an axial direction in relation to the sensor magnet. The angle sensor comprises all necessary functions, such as Hall sensors, an interpolator and driver stages. Analog signals of the sensor magnets are detected by the Hall sensors and, after suitable amplification, passed along to the interpolator. By means of a special processing algorithm, the interpolator generates the high-resolution encoder signal.

With this, two square wave signals that are phase-shifted by 90 °e, as well as an index signal to display output shaft rotation are available at the outputs.

Features and benefits

- Compact modular system and robust housing
- Various resolutions available as standard feature
- Index channel for referencing a rotation of the drive shaft
- Also available as Line Driver version
- Standardized electronic encoder interface
- Flexible customer-specific modifications including custom resolution, direction of rotation, index pulse width and index position are possible

Product code



IE	encoder series
3	3 channel
1024	lines per revolution
L	with integrated Line Driver

IE3 - 1024 L

Encoders

Integrated Magnetic Encoders

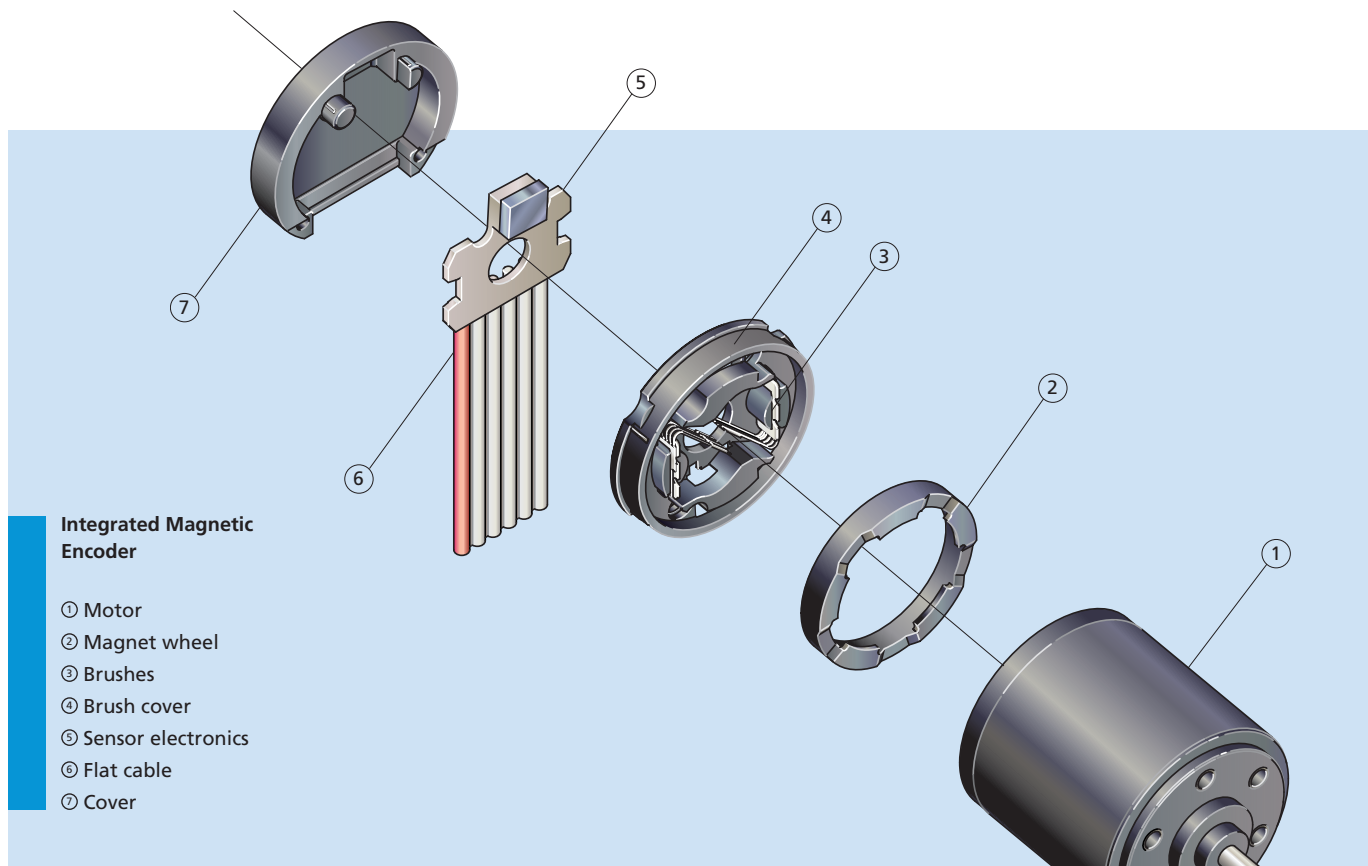

Function

The encoders of the IEH2-4096 and IEH3-4096 series consist of a multi-part magnetic ring, which is attached to the rotor, and an angle sensor. The angle sensor comprises all necessary functions, such as Hall sensors, an interpolator and driver stages. Analog signals of the sensor magnets are detected by the Hall sensors and, after suitable amplification, passed along to the interpolator.

By means of a special processing algorithm, the interpolator generates the high-resolution encoder signal. With this, two square wave signals that are phase-shifted by 90 °e, with up to 4 096 lines per revolution, as well as one additional index signal are available at the outputs.

The encoder is integrated in the motors of the SR series and lengthens these by just 1,4 mm.

Features and benefits

- Extremely compact
- High resolution of up to 16 384 edges per revolution (corresponds to a 0,022° angle resolution)
- No pull-up resistors are necessary at the outputs because there are no open collector outputs
- Symmetric switching edges, CMOS and TTL-compatible
- Different resolutions, according to encoder type, from 16 to 4 096 lines, are available for standard delivery
- High signal quality

Product code



IEH encoder series

2 2 channel

4096 lines per revolution

IEH2 - 4096

Encoders

Absolute Encoders

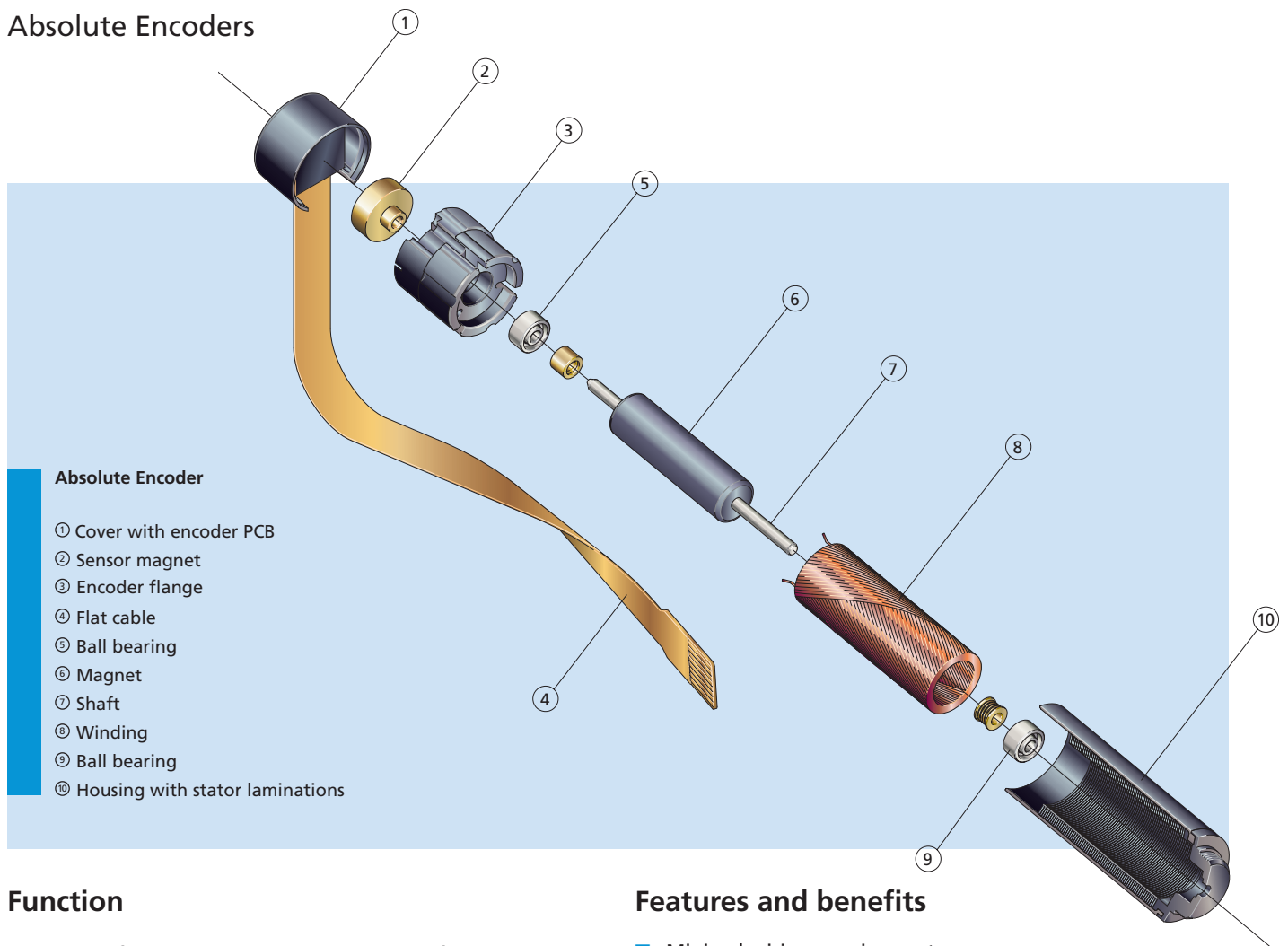

Absolute Encoder

- ① Cover with encoder PCB
- ② Sensor magnet
- ③ Encoder flange
- ④ Flat cable
- ⑤ Ball bearing
- ⑥ Magnet
- ⑦ Shaft
- ⑧ Winding
- ⑨ Ball bearing
- ⑩ Housing with stator laminations

Function

Encoders of the AESM-4096 series consist of a diametrically magnetized, two-pole sensor magnet which is fastened to the motor shaft. A special angle sensor for detecting the motor shaft position is positioned in an axial direction in relation to the sensor magnet. The angle sensor comprises all necessary functions, such as Hall sensors, an interpolator and driver stages. The analog signal of the sensor magnet detected by the Hall sensors is processed, after appropriate amplification, by a special algorithm to produce a high-resolution encoder signal. At the output there is absolute angle information available with a resolution of 4 096 steps per revolution. This data can be queried by a SSI Interface with BISS-C Protocol. The absolute encoder is ideal for commutation, speed control and position control.

Features and benefits

- Minimal wiring requirement
- Absolute angle information directly after power-on
- No referencing necessary
- Enhanced control characteristics even at low rotational speeds
- Flexible customisation of resolution and direction of rotation is possible

Product code



AESM	encoder series
4096	steps per revolution

AESM - 4096

Drive Electronics



Speed Controller

Technical Information

Connection variants

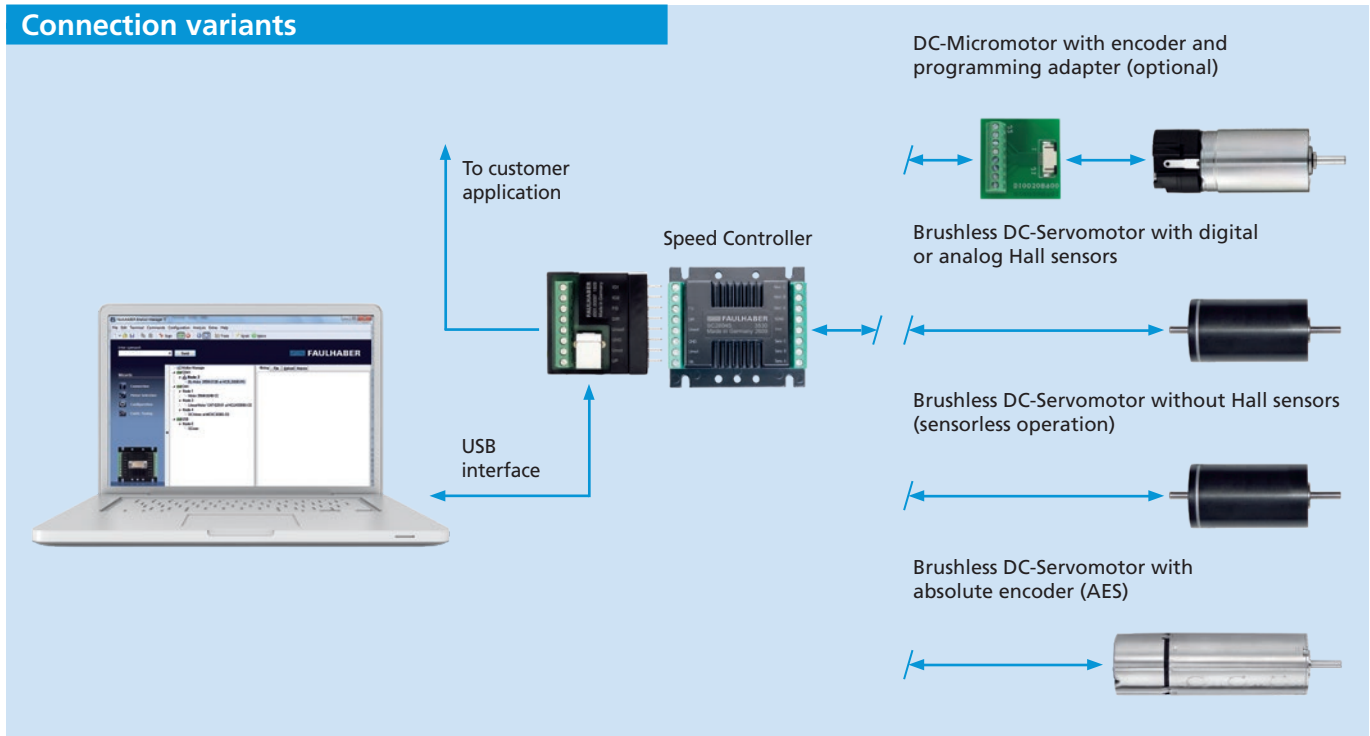

General Information

FAULHABER Speed Controllers are highly dynamic speed controllers for controlling:

- DC-Motors with and without incremental encoder
- BL motors with analog or digital Hall sensors
- BL motors with AES absolute encoder
- BL motors with digital Hall sensors and incremental encoders

Depending on the size and delivery state, different motor and sensor combinations can be operated on the Speed Controller.

Controller	DC sensorless	DC + encoder	BL sensorless	BL + D-Hall	BL + A-Hall	BL + AES
SC 1801	•	•	•	•	(2)	(2)
SC 2402/2804	•	•	•	• (1)	(2)	(2)
SC 5004/5008	-	•	-	• (1)	(2)	(2)

1) Optionally also available with additional incremental encoder input
 2) Optionally available

The different sizes as well as the flexible connection possibilities open a wide range of applications in areas such as laboratory technology and equipment manufacturing, automation technology, pick-and-place machines and machine tools, or pumps.

Product code

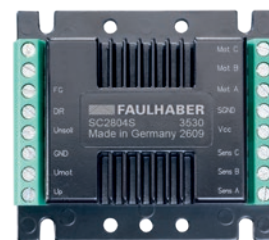

- SC Speed Controller
- 28 Max. supply voltage (28V)
- 04 Max. continuous output current (4A)
- S Housing with screw terminal
- 3530 Operating mode (brushless motor with digital Hall sensors)

SC_28_04_S_3530

Speed Controller

Technical Information

General Information

FAULHABER Speed Controllers can be adapted to the application via the FAULHABER Motion Manager software. The type and scaling of the setpoint input, the operating mode and the control parameters can be adjusted. The USB programming adapter for Speed Controllers is used for configuration.

Speed Controllers are available with or without housing. The variants with housing are connected via screw terminals; the unboxed circuit-board variants can be directly plugged into a master board.

Interfaces – discrete I/O

- Analog input as set value input for setting the speed via PWM or analog voltage value
- Digital input as switching input for defining the direction of rotation of the motor
- Digital output, can be programmed either as frequency output or as error output

Note

Device manuals for installation and start-up, as well as the "FAULHABER Motion Manager" software, are available on request or on the Internet under www.faulhaber.com. Not all Speed Controllers are suitable for all operating modes. Detailed information on the individual operating modes can be found in the respective data sheets as well as in the technical manual.

Benefits

- Compact design
- Scalable in current and voltage
- Simple wiring
- Adapted versions for connecting different motors
- Integrated current limiting (motor protection)
- Controller setting can be configured in combination with Motion Manager via programming adapters
- Extensive range of supported DC-micromotors and brushless DC-servomotors

Speed Controller

Description & Operating Modes

Operating modes

The speed is controlled via a PI controller with variable parameters.

Depending on the version, the speed is determined via the connected sensor system or sensorless from the motor current.

Setpoint specification can be performed using an analog value or a PWM signal. The direction of rotation is changed via a separate switching input; the speed signal can be read out via the frequency output.

The motors can optionally be operated as a voltage controller or in fixed speed mode.

BL motors with digital or analog Hall sensors

In the "BL motors with Hall sensors" configuration, the motors are operated with speed control, whereby the signals from the Hall sensors are used for commutation and determination of the actual speed.

BL motors without Hall sensors (sensorless mode)

No Hall sensors are used in this configuration; instead, the back-EMF of the motor is used for commutation and speed control.

BL motors with absolute encoder

This mode can only be selected in combination with the appropriate hardware.

In this configuration, the encoder outputs an absolute position. This is used for commutation as well as for speed control. Owing to the high resolution of the encoder, it is possible to achieve low speeds in this mode.

BL motors with digital Hall sensors and brake/enable input

In this configuration, the motors are operated with speed control. The additional brake and enable inputs enable easier connection of the control to e.g. PLCs or safety circuits.

BL motors with digital Hall sensors and encoder

In this configuration, the Hall sensors output the information for commutation. The speed is controlled according to the signal from the incremental encoder.

For this reason, it is also possible to achieve extremely low speeds with a high-resolution encoder.

DC-Motors with encoder

In the "DC motors with encoder" configuration, the motors are operated with speed control. An incremental encoder is required as a speed actual value encoder.

DC-Motors without encoder

In the "sensorless DC motors" configuration, the motors are operated with speed control whereby, depending on the load condition, either the back electromotive force (EMF) or IxR compensation is used for speed actual value acquisition.

Matching to the respective motor type is required for this operating mode.

A number of other parameters can also be changed using the "**FAULHABER Motion Manager**" software:

- Controller parameters
- Output current limiting
- Fixed speed
- Encoder resolution
- Speed setpoint specification via analog or PWM signal
- Maximum speed or maximum speed range

Protective functions

FAULHABER Speed Controllers determine the temperature of the motor winding from the motor load characteristic. Dynamically, a peak current which is typically 2 times larger than the continuous current is available as a result; with a continuously higher load, the current is limited to the set continuous current.

In the case of frequent reversing operation with large connected masses, it is recommended to use a Motion Controller.

Special functions

For special applications, special functions such as ramps, switchable fixed speeds or more complex processes can be implemented ex works depending on the additional inputs. This allows FAULHABER Speed Controllers to be optimally adapted to the requirements of the specific application.

Speed Controller

Description & Operating Modes

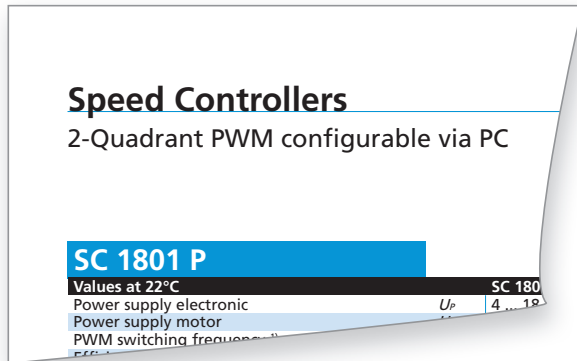

Notes on technical data sheet

The following data sheet values of the Speed Controllers are measured or calculated at an ambient temperature of 22°C.

Speed Controllers generally feature separate supply inputs for motor and electronics with the same ground connection; if necessary, these inputs can also be used as a common supply.

Power supply for electronics U_e [V DC]

Describes the range of the permissible supply voltage for the control electronics.

Power supply for motor U_{mot} [V DC]

Describes the range of the permissible supply voltage of the connected motor.

PWM switching frequency f_{PWM} [kHz]

Pulse width modulation describes the change of the electrical voltage between two values. The motors connected to the SCs have a low electrical time constant. To keep the losses associated with PWM low, a high switching frequency is necessary.

Electronics efficiency η [%]

Ratio between consumed and delivered power of the control electronics.

Max. continuous output current I_{cont} [A]

Describes the current that the controller can continuously deliver to the connected motor at 22°C ambient temperature without additional cooling.

Max. peak output current I_{max} [A]

Describes the current that the controller can reach in S2 operation (cold start without additional cooling) at nominal conditions under constant load for the time specified in the data sheet without exceeding the thermal limit. Unless otherwise defined, the value that applies for the peak current is equal to two times the continuous current.

Standby current for the electronics I_{el} [A]

Describes the additional current consumption of the control electronics.

Operating temperature range [°C]

Shows the minimum and maximum operating temperature under nominal conditions.

Housing material

Housing materials and, if necessary, surface treatment.

Mass [g]

The typical mass of the standard controller may vary due to the different components.

Note

Speed range

The speed that can be reached in combination with a motor depends on the available voltage, the respective motor type and the maximum processing speed of the selected speed controller.

The maximum speed range refers to motors with one pole pair. On motors with a larger number of pole pairs, the speed range decreases accordingly.

$$\text{Maximum speed} = \frac{\text{Maximum speed with number of pole pairs 1}}{\text{Number of pole pairs of the connected motor}}$$

Motion Controllers

Feature Comparison

General Information

FAULHABER Motion Controllers are highly dynamic positioning systems, available in housed and unhoused variants and control DC, LM or BL motors. The Motion Controllers are configured here via the FAULHABER Motion Manager.

The drives can be operated in the network via the CANopen or EtherCAT fieldbus interface (only MC V3.0). In smaller setups, networking can also be performed via the RS232 interface. The Motion Controllers operate in the network in principle as a slave; master functionality for actuating other axes is not provided.

After basic commissioning via Motion Manager, the controllers can alternatively also be operated without communication interface.

Generation V2.5

- Proven technology for BL, DC and LM motors
- Very simple configuration and start-up

- Numerous configuration options
- Successfully used in medical and laboratory technology, equipment manufacturing, automation, medical technology and aerospace
- Also available in very small sizes

Generation V3.0

A new generation of controllers for applications that go beyond the features and performance offered by the V2.5 controller series.

- More power, faster control, new operating modes
- One controller for all motor types and encoder systems
- Flexible use of the I/Os for setpoints and actual values
- Additional I/Os and interfaces
- Sequential programs can be programmed in BASIC for simple, local automation in all interface technologies
- Expanded diagnostic functions
- Simple start-up via Motion Manager beginning with version 6.0

	Generation V2.5		Generation V3.0	
	MCxx 3002	MCxx 3003/06	MC 5004	MC 5005/10
Voltage ranges	<ul style="list-style-type: none"> ■ Motor: max. 30V ■ Electronics: max. 30V, optionally separated 		<ul style="list-style-type: none"> ■ Motor: max. 50V ■ Electronics: max. 50V, separated standard 	
Continuous current	2A	3 / 6A	4A	5 / 10A
Peak current	3A	10A	12A	15 / 30A
Motor types	<ul style="list-style-type: none"> ■ MCDC: DC + Encoder ■ MCBL: BL + A-Hall ■ MCLM: LM + A-Hall ■ MCBL AES: BL + AES Encoder 		<ul style="list-style-type: none"> ■ DC motors with pos. / speed sensor ■ BL motors with pos. / speed sensor ■ LM motors with pos. / speed sensor 	
Speed and position sensors	see motor types		<ul style="list-style-type: none"> ■ DC motors: incremental¹⁾, AES Encoder¹⁾, SSI encoder¹⁾, analog value (potentiometer/tachometer) ■ BL/LM motors: D-Hall, D-Hall + Encoder¹⁾, A-Hall, AES encoder¹⁾, SSI encoder¹⁾, analog value (potentiometer/tachometer) 	
Inputs/outputs	MCDC: DigIn: max. 5 DigOut: max. 1 AnIn ±10V: 1	MCBL/MCLM: DigIn: max. 3 DigOut: max. 1 AnIn ±10V: 1	DigIn: 8 DigOut: 3 AnIn ±10V: 2	DigIn: 3 DigOut: 2 AnIn ±10V: 2
	Optional connection of a second reference encoder (Gearing mode). Not all I/Os available depending on wiring.		Optional connection of a second reference encoder (Gearing mode).	
Communication	RS232 or CANopen		USB, RS232 and/or CANopen, EtherCAT	
Controller	Position, speed, current limiting		Position, speed, current / torque	
Operating modes	<ul style="list-style-type: none"> ■ Depending on the interface variant, position, speed and current control with setpoint input via the interface or analog (RS) 		<ul style="list-style-type: none"> ■ Profile Position mode (PP) and Profile Velocity mode (PV), taking into account profile settings ■ Cyclic Synchronous Position, speed or torque (CSP, CSV or CST) ■ Analog input for position, speed, torque or voltage (APC, AVC, ATC, volt) 	
Profile operation	Linear trapezoidal profiles in all operating modes		Linear or sin ² speed in PP and PV modes	
Autonomous processes	Available in the versions with RS232 interface		Up to eight sequential programs in all versions, with optional password protection	

¹⁾ with and without Line driver

Motion Controllers

Technical Information

Connection variants

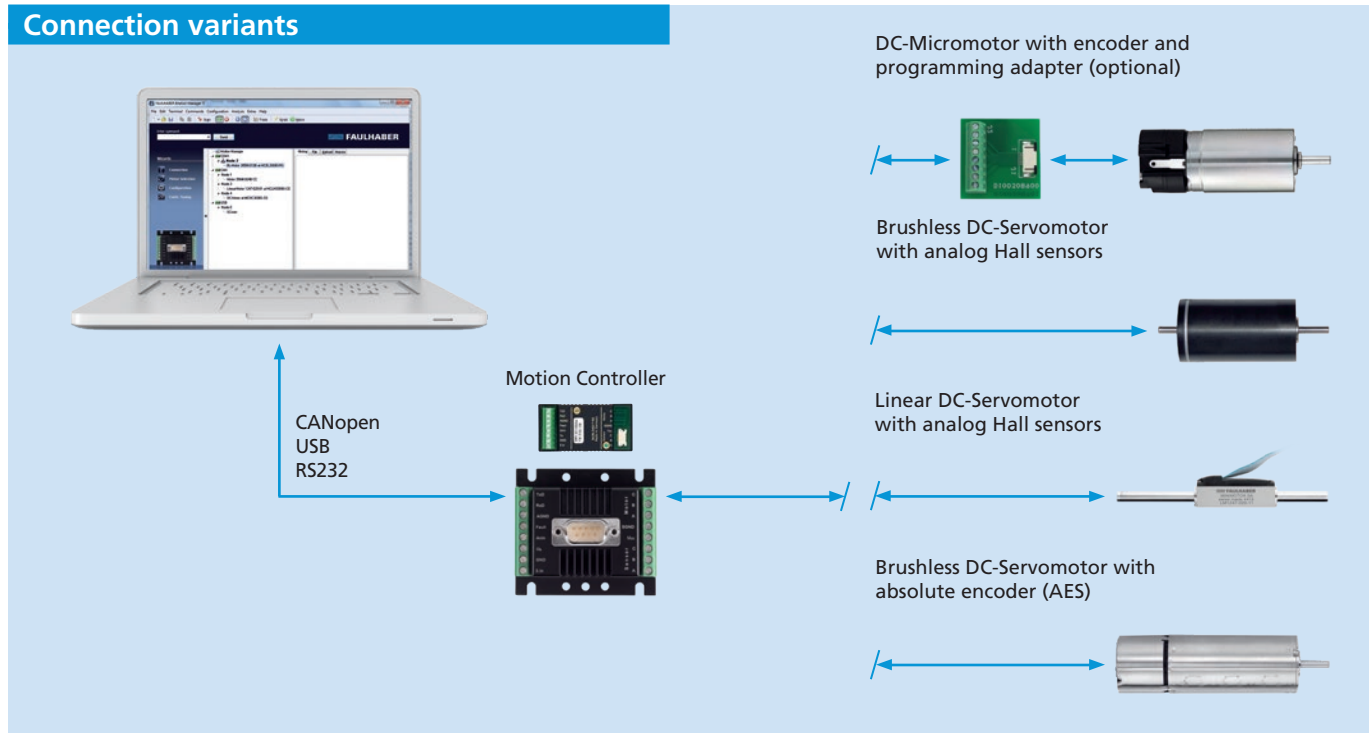

Features

FAULHABER Motion Controllers of generation V2.5 are highly dynamic positioning systems for controlling different motors and sensor systems:

- MCDC 300x: DC-Motors with incremental encoder
- MCBL 300x: BL-motors with analog Hall signals
- MCLM 300x: LM-motors with analog Hall signals
- MCBL 300x AES: BL-motors with absolute encoder

In addition to use as a servo drive with controlled position, the speed can also be controlled. Via the integrated current control, the torque is limited and the electronics or the connected motor protected against overload.

Motion Controllers of generation V2.5 are available in various sizes and performance classes as well as with RS232 or with CAN interface and, as a result, can also be integrated in networks. In addition to operation on a PC, the systems can also be operated on all common industrial controls.

The Motion Controllers are available with or without housing. The variants with housing are connected via screw terminals; the unboxed circuit-board variants can be directly plugged into a master board.

Benefits

- Compact design
- Can be controlled either via RS232 or CAN interface
- Minimal wiring requirements
- Configurable using the "FAULHABER Motion Manager" software and USB interface
- Extensive range of accessories
- Simple start-up

Product code

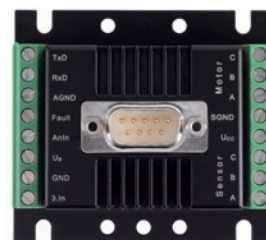

MC	Motion Controller
BL	For Brushless DC-Motors
30	Max. supply voltage (30 V)
06	Max. continuous output current (6 A)
S	Housing with screw terminal
CO	CAN interface

MC BL 30 06 S CO

Motion Controllers

Configuration, networking, interfaces

Operating modes

Positioning operation

The drive moves to the preset target position and, in doing so, maintains the specified limits for speed and position. The dynamics of the control can be adapted to a wide range of loads. Limit switches can be evaluated directly. The position can be initialised via limit switches or a reference switch.

Speed control

The drive controls the preset target speed via a PI speed controller without lasting deviation.

Current control

Protects the drive by limiting the motor current to the set peak current. By means of integrated thermal models, the current is limited to the continuous current if necessary.

Motion profiles

Acceleration and brake ramp as well as the maximum speed can be preset in speed and positioning operation.

Autonomous operation

In version RS, freely programmable processes can be stored in the Motion Controller. Operation is then also possible without RS232 interface.

Protective features

- Protection against ESD
- Overload protection for electronics and motor
- Self-protection from overheating
- Overvoltage protection in generator mode

Operating modes (RS version)

- Position control
 - with setpoint input via the interface
 - with analog setpoint
 - gearing mode
 - stepper motor operation
- Speed control
 - with setpoint input via the interface
 - with analog setpoint
- Torque control
 - with setpoint input via the interface
 - with analog setpoint
- Operation as Servo Amplifier in voltage controller mode

Operating modes (CO version)

- Profile Position mode (PP)
- Profile Velocity mode (PV)
- Homing mode

Options

Separate supply of power to the motor and electronic actuator is optional (important for safety-critical applications).

Third input is not available with this option. Depending on the controller, additional programming adapters and connection aids are available. The modes and parameters can be specially pre-configured on request.

Interfaces – discrete I/O

Setpoint input

Depending on the operating mode, setpoints can be input via the command interface, via an analog voltage value, a PWM signal or a quadrature signal.

Error output (Open Collector)

Configured as error output (factory setting). Also usable as digital input, free switch output, for speed control or signaling an achieved position.

Additional digital inputs

For evaluating reference switches.

Interfaces – position encoder

Depending on the model, one of the listed interfaces for the position and speed sensor is supported.

Analog Hall signals

Three analog Hall signals, offset by 120°, in Brushless DC-Motors and Linear DC-Servomotors.

Incremental encoder

In DC-Micromotors and as additional sensors for Brushless DC-Motors.

Absolute encoder

Serial SSI port, matching Brushless DC-Servomotors with AES encoders.

Motion Controllers

Configuration, networking, interfaces

Networking

FAULHABER Motion Controllers of generation V2.5 are available in all two networking versions.

RS – systems with RS232 interface

Ideal for equipment manufacturing and for all applications in which the controller is also to be used without a higher level controller. Using Net mode, it is also possible to operate multiple RS controllers on an RS232 interface.

CO – CANopen acc. to CiA 402

The ideal variant for the operation of a FAULHABER Motion Controller on a PLC – directly via the CANopen interface or via a gateway on, e.g., Profibus/ProfiNET or on EtherCAT.

The CO version provides the CiA 402 standard operating modes. All the parameters are directly stored in the object directory. Configuration can therefore be performed with the help of the FAULHABER Motion Manager or by applying available standardized configurations tools common to the automation market.

The CO version is particularly suitable for users who already use various CANopen devices or operate the Motion Controllers on a PLC. With dynamic PDO mapping it is possible to achieve highly efficient networking on the CAN.

Interfaces – Bus Connection

Version with RS232

For coupling to a PC with a transfer rate of up to 115 kbaud. Multiple drives can be connected to a single controller using the RS232 interface. As regards the control computer, no special arrangements are necessary. The interface also offers the possibility of retrieving online operational data and values.

A comprehensive ASCII command set is available for programming and operation. This can be preset from the PC using the “FAULHABER Motion Manager” software or from another control computer.

Additionally, there is the possibility of creating complex processes from these commands and storing them on the drive. Once programmed as a speed or positioning controller via the analog input, as step motor or electronic gear unit, the drive can operate independently of the RS232 interface.

Version with CANopen CO

A controller variant with CANopen interface is available to allow optimal integration in a wide variety of different applications. CANopen is ideal for networking microdrives because the interface can also be integrated in small electronics modules. Its size and the efficient communication procedures mean that it is ideally suited for use in industrial automation.

Features CO

	CO
NMT with node guarding	•
Baud rate	1 Mbit max., LSS
EMCY object	•
SYNCH object	•
Server SDO	1 x
PDOs	4 x Rx 4 x Tx each with dynamic mapping
PDO ID	adjustable
Configuration	Motion Manager from V5
Trace	Any PDO
Standard operating modes - Profile Position Mode - Profile Velocity Mode - Homing	•

The model supports the CANopen communication profile acc. to CiA 301 V4.02. Transfer rate and node number are set via the network in accordance with the LSS protocol as defined in CiA 305 V1.11.

For this purpose, we recommend using the latest version of the FAULHABER Motion Manager.

Note

Device manuals for installation and commissioning, communication and function manuals as well as the "FAULHABER Motion Manager" software are available on request or on the Internet under www.faulhaber.com.

Motion Controllers

Configuration, networking, interfaces

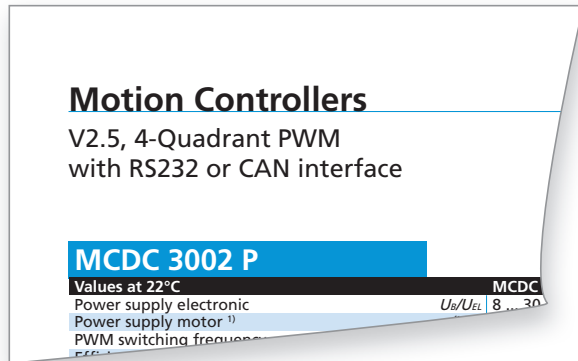

Notes on technical data sheet

The following data sheet values of the Motion Controllers of generation V2.5 are measured or calculated at an ambient temperature of 22°C. In their standard version, the Motion Controllers do not have separate supply inputs for motor and electronics, but can optionally be equipped with these inputs (via 3rd input).

Power supply for electronics U_B / U_{EL} [V DC]

Describes the range of the permissible supply voltage for the control electronics.

Power supply for motor -- U_B [V DC]

Describes the range of the permissible supply voltage of the connected motor.

PWM switching frequency f_{PWM} [kHz]

Pulse width modulation describes the change of the electrical voltage between two values. The motors connected to the MCs have a low electrical time constant. To keep the losses associated with PWM low, a high switching frequency is necessary.

Electronics efficiency η [%]

Ratio between consumed and delivered power of the control electronics.

Max. continuous output current I_{cont} [A]

Describes the current that the controller can continuously deliver to the connected motor at 22°C ambient temperature without additional cooling.

Max. peak output current I_{max} [A]

Describes the current that the controller can reach in S2 operation (cold start without additional cooling) at nominal conditions under constant load for the time specified in the data sheet without exceeding the thermal limit. Depending on the size and version, the value is up to three times higher for the ratio of peak current to continuous current.

Standby current for the electronics I_{el} [A]

Describes the additional current consumption of the control electronics.

Operating temperature range [°C]

Shows the minimum and maximum operating temperature under nominal conditions.

Housing material

Housing materials and, if necessary, surface treatment.

Mass [g]

The typical mass of the standard controller may vary within the individual interface variants due to the different components.

Note

Speed range

The speed that can be reached in combination with a motor depends on the available voltage, the respective motor type and the maximum processing speed of the selected motion controller.

The maximum speed range refers to motors with one pole pair. On motors with a larger number of pole pairs, the speed range decreases accordingly.

$$\text{Maximum speed} = \frac{\text{Maximum speed with number of pole pairs 1}}{\text{Number of pole pairs of the connected motor}}$$

Motion Controller

Technical Information



Features

FAULHABER Motion Controllers of generation V3.0 are highly dynamic, optimally tuned positioning controllers for use in combination with DC-micromotors as well as BL and LM DC-servomotors from FAULHABER's line of motors. The motor type can be configured during commissioning using the FAULHABER Motion Manager from version 6.0.

In addition to use as a servo drive with controlled position, the speed or current can also be controlled. The actual values for speed and position can be ascertained here using a number of supported sensor systems. Limit switches and reference switches can be directly connected.

The control setpoints can be preset via the communication interface, via the analogue input or a PWM input or can come from internally stored sequential programs.

Supported as communication interfaces are – depending on the device – USB and RS232, CANopen and, optionally, EtherCAT. All functions of the drive are available here without limitation via all interfaces.

FAULHABER Motion Controllers of generation V3.0 are available in three sizes and three power classes:

- **MC 5004** – with a continuous current of up to 4 A, can be plugged directly into a motherboard and offers most I/Os
- **MC 5005** – with a continuous current of up to 5 A, is the ideal partner for most motors from the FAULHABER product portfolio
- **MC 5010** – with a continuous current of up to 10 A, is also suitable for applications with higher power requirements. Especially well suited for use in combination with the highly dynamic BL motors.

The possible applications are diverse: from laboratory automation to industrial equipment manufacturing, automation technology and robotics to aerospace.

The connection to the motors is established via pre-configured plugs or extension cables, which are available for all supported motors as options or as accessories.

Benefits

- One controller for all motor types and encoder types
- Very dynamic control
- Ideally matched to FAULHABER DC, BL and LM motors
- Various setpoint and actual value interfaces
- Stand-alone operation possible in all variants
- Connection via simple plug concept
- Fast feedback with status LEDs
- Commissioning with the free FAULHABER Motion Manager from version 6.0
- Extensive mounting accessories available

Product code

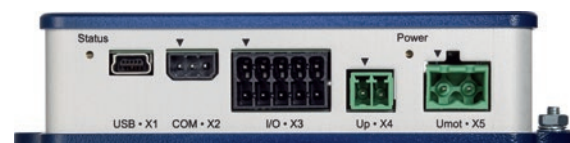

MC	Motion Controller
50	Max. supply voltage (50 V)
05	Max. continuous output current (5 A)
S	Housing with plug-in connections
RS	RS232 interface

MC_50_05_S_RS

Motion Controller

Technical Information

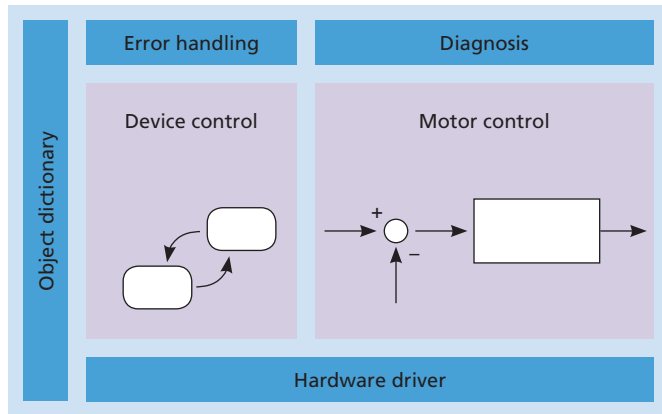

Operating modes

Motor control

Current, speed and position of the drive can be controlled via the controller cascade. By means of the optional pilot paths, even the fastest movements can be reliably controlled in a reproducible manner. Adjustable filters enable adaptation to a wide range of encoders and loads.

Motion profiles

Acceleration and brake ramp as well as the maximum speed can be preset in speed and positioning operation in the Profile Position Mode (PP) and Profile Velocity Mode (PV) operating modes.

Autonomous operation

Up to eight sequential programs written in BASIC can be stored and executed directly on the controller. One of these can be configured from the autostart application. Access protection can be activated.

Protection and diagnostic functions

FAULHABER Motion Controllers of generation V3.0 protect motors and electronics against overload by means of thermal models. The supply voltage is monitored and can also be used in regenerative operation. External devices are thereby protected against overvoltage during dynamic operation.

Profile Position Mode (PP) / Profile Velocity Mode (PV)

For applications in which only the target of the movement is specified for the controller. The acceleration and brake ramp as well as a possible maximum speed are taken into account via the integrated profile generator. Profile-based movements are, thus, suited for a combination with standard networks, such as RS232 or CANopen.

Cyclic Synchronous Position (CSP) / Cyclic Synchronous Velocity (CSV) / Cyclic Synchronous Torque (CST)

For applications in which a higher-level controller performs the path planning, even synchronised for multiple axes. The setpoints for position, speed and current are constantly updated. Typical update rates are in the range of a few milliseconds. Cyclic modes are, thus, primarily suited for combination with EtherCAT. CANopen can also be used.

Analogue Position Control (APC) / Analogue Velocity Control (AVC) / Analogue Torque Control (ATC)

For applications in which the setpoints of the control are specified as an analogue value or, e.g., via a directly connected reference encoder. These operating modes are therefore particularly well suited for stand-alone operation without higher-level master.

Voltage mode (VOLT)

In the voltage mode, only a current limiting controller is used. All control loops are closed by a higher-level system. The setpoint can be set via the communication system or via an analogue input.

Interfaces – discrete I/O

Three to eight digital inputs for connecting limit and reference switches or for connecting a reference encoder. The logic levels are switchable.

Two analogue inputs ($\pm 10V$) are available that can be freely used as setpoint or actual value.

Two to three digital outputs are available that can be freely used as error output, for direct actuation of a holding brake or as flexible diagnosis output.

Interfaces – position encoder

FAULHABER Motion Controllers of generation V3.0 support all sensor systems typically used on micro motors for position and speed as well as analogue or digital Hall signals, incremental encoders with and without Line Driver or protocol-based AES or SSI encoders.

Options

All controllers can optionally be equipped with an EtherCAT interface.

For highly dynamic applications, the use of a braking chopper can help to dissipate recovered energy.

Networking

RS – systems with RS232 interface

Ideal for device construction and for all applications in which the Motion Controller is to be operated on an embedded controller. Using Net mode, it is also possible to operate multiple RS controllers on an RS232 interface. The transmission rate can lie between 9600 baud and 115 kbaud.

CO – CANopen acc. to CiA 402

The ideal variant for the operation of a FAULHABER Motion Controller on a PLC – directly via the CANopen interface or via a gateway on, e.g., Profibus/ProfiNET or on EtherCAT. Dynamic PDO mapping as well as node guarding or heartbeat are supported. Refresh rates for setpoint and actual values are typically from 10 ms here.

ET – EtherCAT

Motion Controller with direct EtherCAT interface. The controllers are addressed via CoE via the CiA 402 servo drive profile. Ideal in combination with a high-performance industrial controller that also performs path planning and interpolation of the movement for multiple axes. Refresh rates for setpoint and actual values from 0.5 ms are supported.

Interfaces – Bus Connection

Configuration

All Motion Controllers of generation V3.0 are equipped with a USB interface. This is intended primarily as a configuration interface. Via a USB to RS232 or USB to CAN converter, the drives can alternatively likewise be configured without restriction.

All described operating modes and functions are available independent of the used communication interface.

The interfaces can also be used in parallel, thereby allowing a drive to be integrated in an industrial interface via the CANopen or EtherCAT interface, while diagnostics are evaluated with the trace function via the USB interface.

General Information

System description

The products of the MC 5004, MC 5005 and MC 5010 series are variants of the FAULHABER Motion Controllers with and without housing and control either DC, LM or BL motors. The Motion Controllers are configured here via the FAULHABER Motion Manager.

The drives can be operated in the network via the CANopen or EtherCAT fieldbus interface. In smaller setups, networking can also be performed via the RS232 interface.

The Motion Controller operates in the network in principle as a slave; master functionality for actuating other axes is not provided.

After basic commissioning via the Motion Manager, the controllers can alternatively also be operated without communication interface.

The controllers of the MC 5004 series can be plugged into a motherboard via the 50-pin connector strip. For this purpose, FAULHABER offers a motherboard for connecting up to four controllers.

The controllers of the MC 5005 and MC 5010 series are secured to a flat base plate via the mounting holes. With optional accessories, mounting is also possible on a DIN rail.

Modifications and accessories

FAULHABER specialises in the adaptation of its standard products for customer-specific applications. The following standard options and accessory parts are available for FAULHABER Motion Controller MC V3.0:

- Connection cables for the supply and motor side
- Adapter sets for encoders
- Connector sets
- Motherboard MC 5004
- Programming adapter
- Starter kits
- Customized special configuration and firmware

Functional safety

STO – Safe Torque Off

The products of the MC 5004 P STO series have a function which safely shuts down the torque via a certified integrated safety circuit.

Disconnection through two redundant optocoupler inputs ensures operation up to safety integrity level SIL3 as defined by IEC 61800-5-2 and performance level PL e as defined by EN ISO 13849-1. Signalling and visualisation is via local LEDs as well as two separate outputs for status and error reporting.

The corresponding EC type examination is available for download at www.faulhaber.com.

Motion Controller

Technical Information

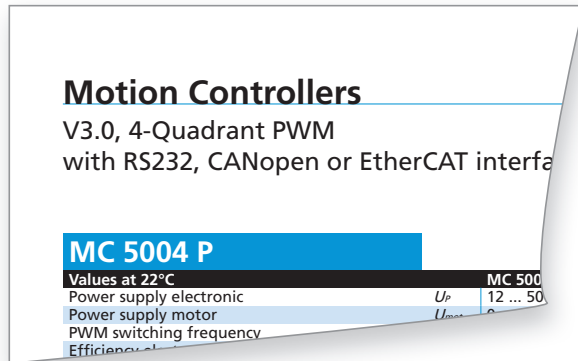

Explanatory Notes for Data Sheets

The following data sheet values of the Motion Controllers are measured or calculated at an ambient temperature of 22°C.

Motion Controllers of generation V3.0 generally feature – with the same ground connection – separate supply inputs for motor and electronics; if necessary, these inputs can also be used as a common supply.

Power supply for electronics U_p [V DC]

Describes the range of the permissible supply voltage for the control electronics.

Power supply for motor U_{mot} [V DC]

Describes the range of the permissible supply voltage for the motors connected to the MCs.

PWM switching frequency f_{PWM} [kHz]

Pulse width modulation describes the change of the electrical voltage between two values. Bell-type armature motors have a low electrical time constant. To keep the losses associated with PWM low, a high switching frequency is necessary. In generation V3.0, this value is fixed at 100 kHz. Through the type of pulse pattern generation (centre aligned), the switching frequency effective at the motor is twice as high.

Electronics efficiency η [%]

Ratio between consumed and delivered power of the control electronics.

Max. continuous output current I_{cont} [A]

Describes the current that the controller can continuously deliver to the connected motor at 22°C ambient temperature without additional cooling.

Max. peak output current I_{max} [A]

Describes the current that the controller can reach in S2 operation (cold start without additional cooling) at nominal conditions under constant load for the time specified in the data sheet without exceeding the thermal limit. Unless otherwise defined, the value that applies for the peak current is equal to three times the continuous current.

Standby current for the electronics I_{el} [A]

Describes the additional current consumption of the control electronics.

Operating temperature range [°C]

Shows the minimum and maximum operating temperature under nominal conditions.

Mass [g]

The typical mass of the standard controller may vary within the individual interface variants due to the different components.

Note

Speed range

The speed that can be reached in combination with a motor depends on the available voltage, the respective motor type and the maximum processing speed of the selected motion controller.

The maximum speed range refers to motors with one pole pair. On motors with a larger number of pole pairs, the speed range decreases accordingly.

$$\text{Maximum speed} = \frac{\text{Maximum speed with number of pole pairs 1}}{\text{Number of pole pairs of the connected motor}}$$

Manuals/Software

Device manuals for installation and commissioning, communication and function manuals as well as the “FAULHABER Motion Manager” software are available on request or on the Internet under www.faulhaber.com.

Motion Controller Software

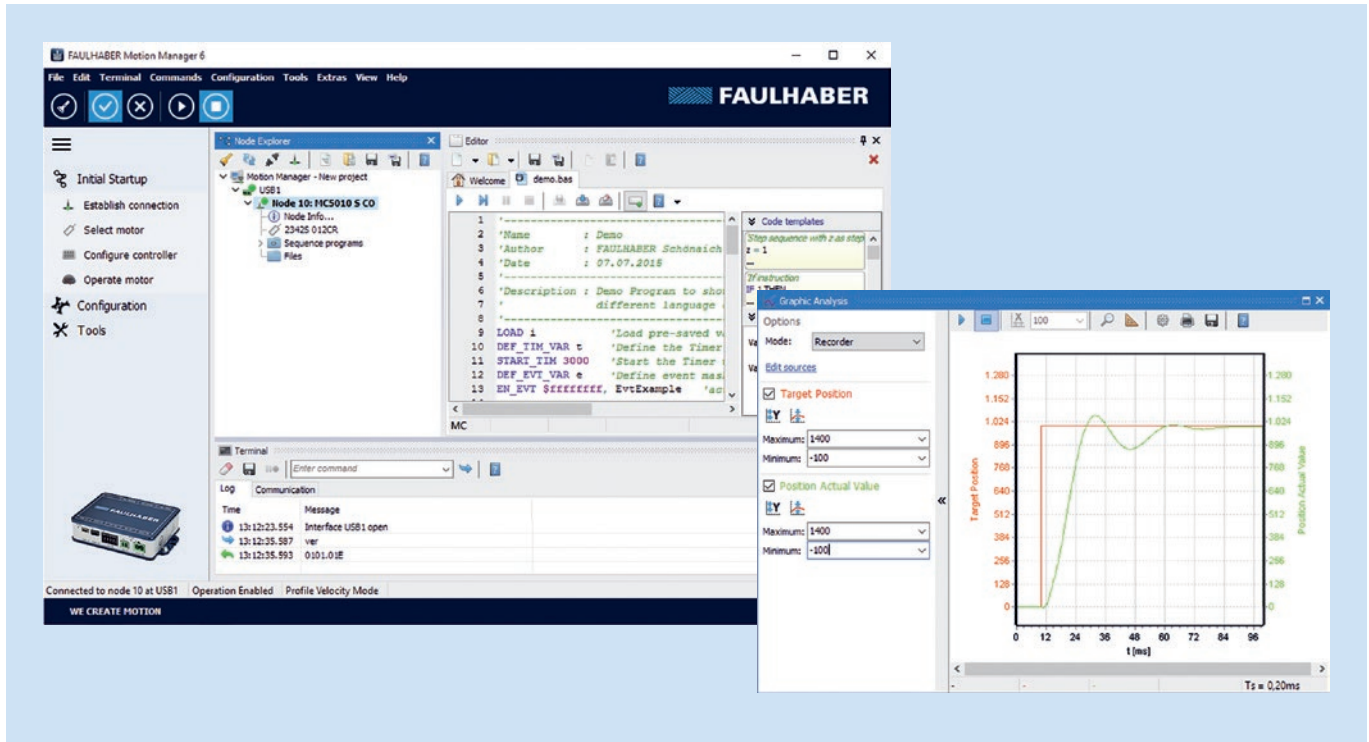

FAULHABER Motion Manager

The powerful 'FAULHABER Motion Manager' software is available for commissioning and configuring drive systems with motion and speed controllers.

Motion Manager generally supports interfaces RS232, USB and CANopen. Depending on the connected device, it may, however, be necessary to use an interface adapter, e.g., during the configuration of a Motion Control System via USB.

The graphical user interface makes uniform and intuitive procedures possible independent of the device family and interface used.

Supported Interfaces	Motion Controllers Motion Control Systems	Speed Controller Speed Control Systems
RS232	•	•
USB	•	•
CANopen	•	

The software is characterised by the following features:

- Start-up support wizards
- Access to connected devices via Node-Explorer
- Configuration of drive functions and controller parameters using convenient, coordinated dialogues for the respective device family
- Context-sensitive online help
- Only for Motion Controllers:
 - Graphical analysis tools for drive behaviours and controller setting
 - Macro function for execution of program sequences
 - Development environment for sequential programmes and Visual Basic Script programmes

New features in Motion Manager 6:

- Completely revised user interface with window docking function
- Node-Explorer with integrated project management
- Support for the MC V3.0 family Motion Controller
 - Controller configuration with route identification
 - Expanded graphical analysis options
 - Further tools for operation and controller tuning

Motion Controller

Software

“FAULHABER Motion Manager” for Microsoft Windows can be downloaded from www.faulhaber.com free of charge.

Commissioning and Configuration

FAULHABER Motion Manager can be used to easily access settings and parameters of the connected controller.

Wizards assist during the commissioning of a controller. Drive units detected on the selected interfaces are displayed in the device explorer.

The current interface and display settings can be saved in project files.

Sequential programs for saving and execution can be created, edited, transferred and executed on the devices. Possibilities for error detection and monitoring the program flow are also available.

The operation of a controller and the execution of motion tasks are performed via:

- Graphical operating elements
- Command entries
- Macro functions
- Programming of sequences via Visual Basic Script (VBScript)

Control parameters such as setpoints and actual values can be recorded in Logger or Recorder mode via a graphical analysis function. Additional tools are available for the creation and optimisation of control parameters.

Stepper motors Motion Controller

Technical Information

Connection variants

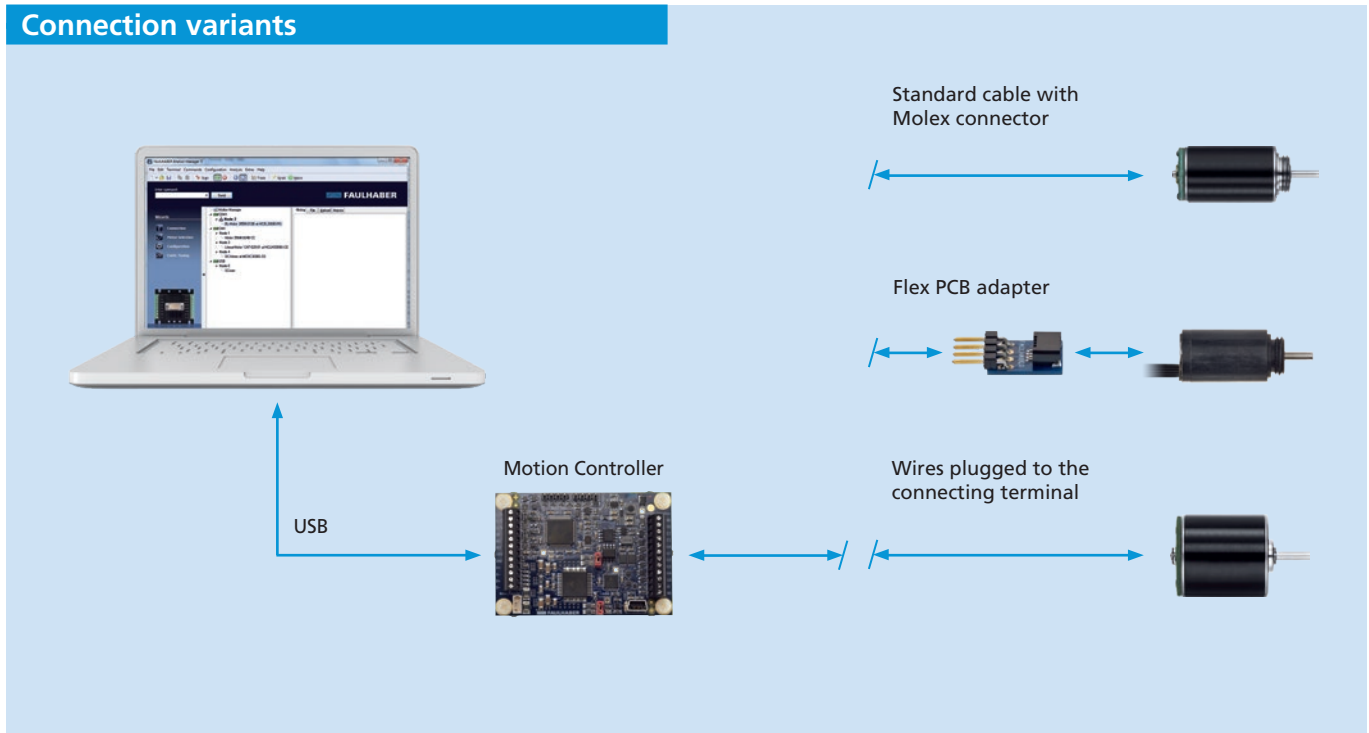

Features

FAULHABER stepper motor motion controllers are highly dynamic positioning systems tailored specifically to the requirements of micro stepper motor operations.

In addition to be able to control the whole FAULHABER stepper motor range, the controllers are capable of managing three axes positioning (requires 2 additional boards). Reference search and encoder management functions are part of the numerous features offered by the controllers.

A complete IDE is included, allowing the user to benefit from the full range of functionalities, through a very comprehensive and user friendly interface.

The integrated systems require less space, as well as making installation much simpler thanks to their reduced wiring.

Benefits

- Fully programmable via software (Graphic User Interface)
- USB interface
- 9V...36VDC / 50mA to 1.1A
- Microstepping up to 1/256
- 4 GPI and 7 GPO
- Can be used as step/direction driver only
- Reference input (for homing functions)
- Compatible with LabView
- Board size: 68mm x 47.5mm

Product Code



MC	Motion Controller
ST	Stepper Motor
36	Max. supply voltage (36V)
01	Max. continuous output current (1A)

MC ST 36 01

Stepper motors Motion Controller

Technical Information

Main characteristics

Motion controller

- Motion profile calculation in real-time
- On the fly alteration of motor parameters (e.g. position, velocity, acceleration)
- High performance microcontroller for overall system control and serial communication protocol handling

Bipolar stepper motor driver

- Up to 256 microsteps per full step
- High-efficient operation, low power dissipation
- Dynamic current control
- Integrated protection

Software

- TMCL™: standalone operation or remote controlled operation
- PC-based application development software TMCL™ – IDE available for free.

Operating modes

Standalone

A program is stored in the controller board memory, and starts when the system is powered ON. The software is able to react with external stimulus, such as digital I/Os, encoders, sensors, etc. Standard processor instructions list as well as complete list of motor positioning control functions are available for the programmer.

Direct mode

Using IDE "direct mode" functions, the user is able to send instructions to the board one by one, through USB link. Status information and position/speed values can be read in real time by the user, thanks to dedicated GUI.

Remote software

The controller can be remotely controlled through USB link, by any user developed software. Labview and C++ libraries are available to be used with the controller.

Special functions

Speed profiles

Motors movements are realized using user definable speed profiles. The latter can be setup using a complete parameter calculator interface, helping the user to find the most suited speed values.

StallGuard™

Stall detection feature allows the controller to react in case of step losses, and can also be used to detect any motor hard stop reach.

CoolStep™

Current flowing to the motor is automatically adapted in case of load variation. This feature allows a reduced power consumption of the whole system.

Homing

Reference search process can be done automatically by the controller on startup. The user can setup the way to perform the operation (direction, switches number, origin location, etc.).

Interfaces

- USB device interface (on-board mini-USB connector)
- 6x open drain outputs (24V compatible)
- REF_L / REF_R / HOME switch inputs (24V compatible with programmable pull-ups)
- 1x S/D input for the on-board driver (on-board motion controller can be deactivated)
- 2x step / direction output for two separate external drivers (in addition to the on-board)
- 1x encoder input for incremental a/b/n encoder
- 3x general purpose digital inputs (24V compatible)
- 1x analog input (0 .. 10V)

Please note: Not all functions are available at the same time as connector pins are shared.

Notes

Device manuals for installation and start up, communication and function manuals, and the "TMCL™ – IDE" software are available on request and on the Internet at www.faulhaber.com.

Stepper motors Motion Controller Software

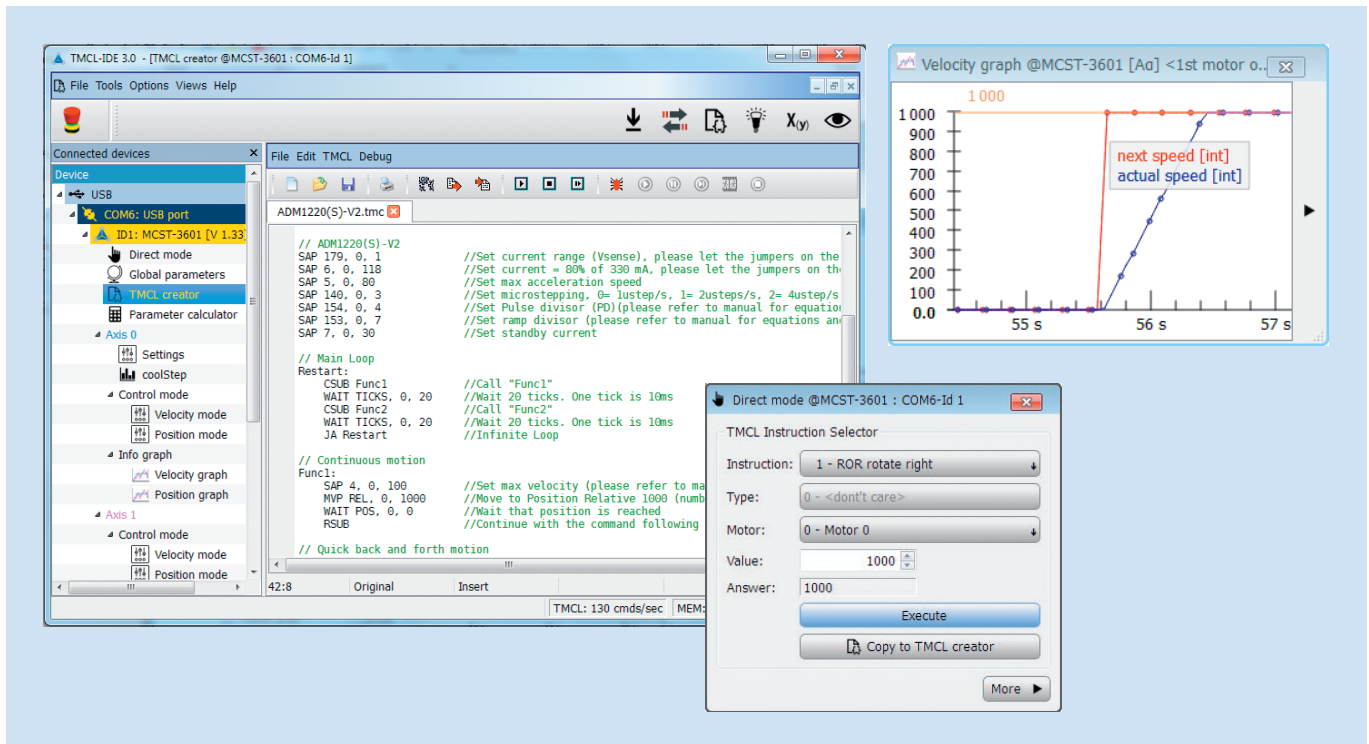

TMCL™ – IDE

The high-performance software solution “TMCL™ – IDE” enables users to control and configure the stepper motors controller, through USB interface.

“TMCL™ – IDE” software and lots of program examples can be downloaded free of charge from www.faulhaber.com.

Startup and configuration

Drivers and libraries are automatically installed together with the TMCL™-IDE software. Connected controller device is immediately detected and recognized by the software. The graphical user interface can be used to read out, change and reload configurations. Individual commands or complete parameter sets and program sequences can be entered and transferred to controller.

Operation of drives is also supported by several wizards, helping user to easily setup all the parameters.

Quickstart, hardware and firmware complete user manuals are also available for the user and can be downloaded free of charge from www.faulhaber.com. Please refer to the Quickstart manual before first use.

More information



[faulhaber.com](https://www.faulhaber.com)



[faulhaber.com/facebook](https://www.faulhaber.com/facebook)



[faulhaber.com/youtubeEN](https://www.faulhaber.com/youtubeEN)



[faulhaber.com/linkedin](https://www.faulhaber.com/linkedin)



[faulhaber.com/instagram](https://www.faulhaber.com/instagram)