

Palm grip

B7 / B8



The palm grip B7 / B8 has different equipment options for many requirements. It is compatible with our multi-axis controller or mounted on hydraulic drives. The palm grip has a highly flexible single wire (0,1 mm², 450 mm long). The mounting piece for the drive rod can be supplied with a tapped hole 12 mm (standard) or 10 mm.

Technical data

Operating temperature	-40°C to +85°C
Degree of protection	Control element up to IP67
Contact complement	1,5A 24 V DC13 (*1 0,1A 24 V DC13)



Example

	B7	-2D	W	K	SE	S9	PA13	-X
Basic unit								
B7	Palm grip left							
B8	Palm grip right							
Digital actuating element								
D	Push button							
	Colour: red, black, yellow, green, white, orange							
D	Push button KDA21 *1							
	Colour: red, black, yellow, green, blue, white, orange							
W	Rocker switch T-0-T, Colour: red, black, yellow, blue, white							
W	Rocker switch 0-T, Colour: red, black, yellow, blue, white							
W	Rocker switch R-0-T, Colour: red, black, yellow, blue, white							
W	Rocker switch R-0-R, Colour: red, black, yellow, blue, white							
W	Rocker switch 0-R, Colour: red, black, yellow, blue, white							
W	Rocker switch R-R, Colour: red, black, yellow, blue, white							
K	Lever switch							
A13	Rotary grip T-0-T							
SE	Sensor button capacitive with external control electronics							
S	Sensor button capacitive without external control electronics (Consistent with V85 / VV85 with interface E1xx to E6xx, E907 and V25/V27 with interfaces E3xx + E4xx)							
V	Vibrator							
	Impulse 24 V DC ED 100%							
Analog actuating element								
S12	Hall-thumb rocker (see page 100)							
	Output 0,5...2,5...4,5 V inverse dual							
V21	Hall-minijoystick (see page 45)							
	Output 0,5...2,5...4,5 V inverse dual							
PA13	Rotary grip							
	Potentiometer T375 2 x 5 kOhm with direction contacts							
H13	Hall-Rotary grip							
	Output 0,5...2,5...4,5 V inverse dual							

Technical details may vary based on configuration or application! Technical data subject to change without notice!

B7 -2D W K SE S9 PA13 -X

Special model

X Special / customer specified

Attachments

Z01	Bellow KMD 109	10300009
Z02	Bellow KMD 190	10300093
Z03	Rosette KBF 905 with 4 screws M5x15 necessary for bellow KMD 190	5209900404

B7

Edition:
Push button installed Pos. 1 - 8

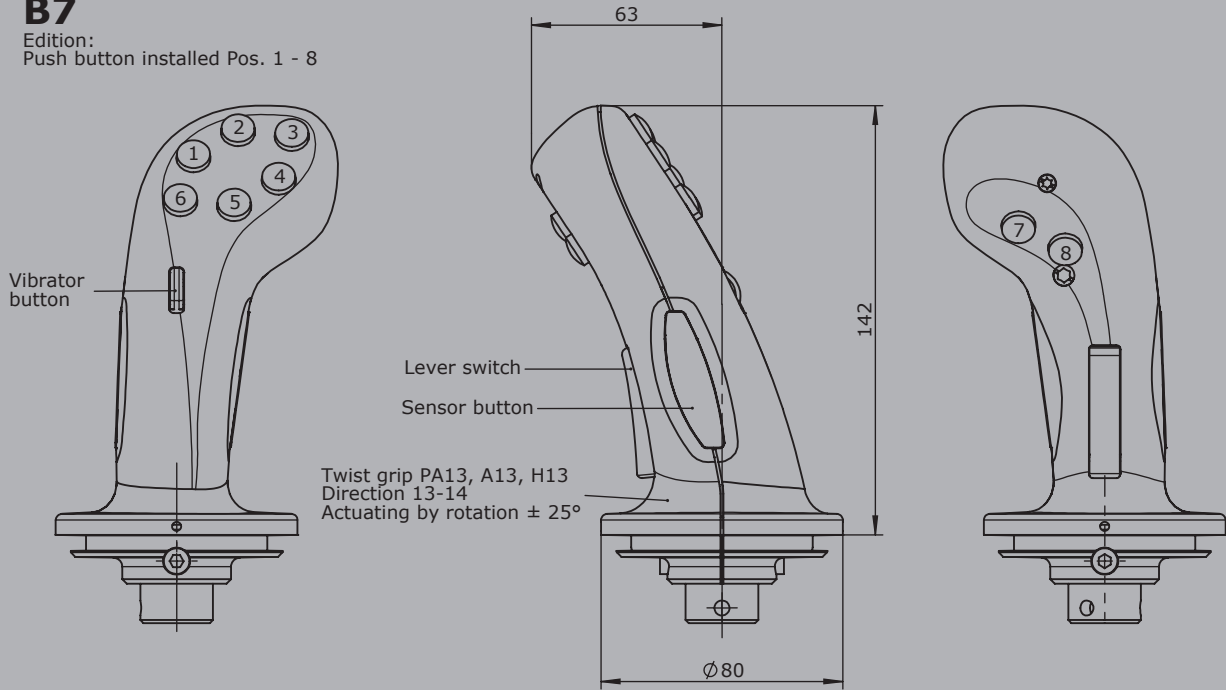

B8

Edition:
Push button installed Pos. 1 - 8

Edition:
Multi-axis controller V21
Push button installed Pos. 5,6,7,8

Edition :
Hall Rocker switch
Push button installed Pos. 1,5,6,8

