

◀40X40X28mm Series▶

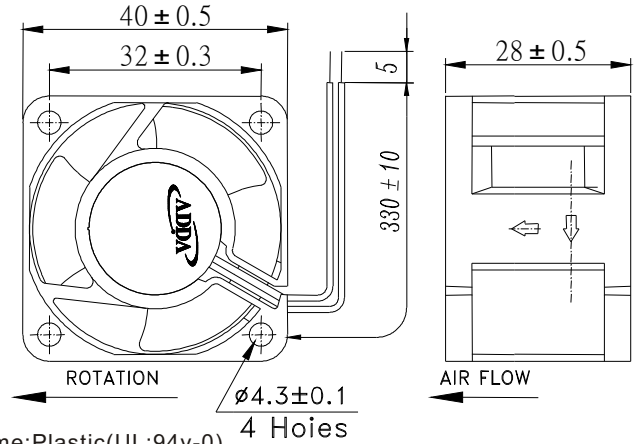

Spot cooling, also suitable for small space requirements, laptops PC and notebook, etc.,

External Dimensions



Frame: Plastic(UL:94v-0)
 Impeller: Plastic(UL:94v-0)
 Bearing: Ball bearing
 Lead wire: UL1007AWG24
 OPERATING TEMP*:-10C~70C
 VOLTAGE AVAILABLE: 12V, 24V
 *:-10C~60C for fans with sleeve/ball combination bearings.

Specifications(Nominal)

*:Noise is measured at the distance of one(1) meter from the axis of intake.

Frame size (mm)	Model No.	Bearing System Type	Rated Voltage (v)	Rated Current (A)	Rated Power (W)	Rated Speed (rpm)	Bearing type: =Ball =Sleeve =1B1S =Hypro bearing				Noise Level (dB/A)	Weight (g)
							Maximum AirFlow (CMM)	Maximum AirFlow (CFM)	Maximum Pressure (InAq)	Maximum Pressure (mmAq)		
	AD0412UB-B31		12	0.23	2.76	10000	0.380	13.50	0.480	11.99	42.5	
	AD0412HB-B31		12	0.22	2.64	9000	0.342	12.13	0.391	9.77	38.8	
	AD0412HB-B32		12	0.22	2.64	9000	0.342	12.13	0.391	9.77	38.8	
	AD0412HB-B33		12	0.22	2.64	9000	0.342	12.13	0.391	9.77	38.8	
40X40X28	AD0412MB-B31		12	0.18	2.16	7500	0.270	9.60	0.232	5.81	36.5	38
	AD0412DB-B31		12	0.07	0.84	4500	0.166	5.90	0.094	2.34	19.2	
	AD0424UB-B31		24	0.23	5.52	13000	0.485	17.22	0.753	18.83	49.7	
	AD0424HB-B31		24	0.12	2.88	8100	0.342	12.13	0.391	9.77	36.2	
	AD0424HB-B33		24	0.12	2.88	8100	0.342	12.13	0.391	9.77	36.2	

Specifications subject to change without notice.

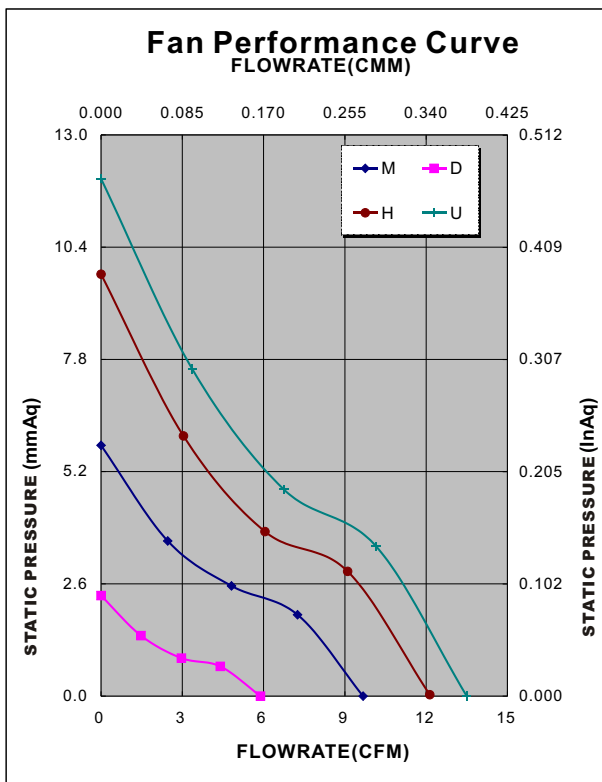

*Motor protective circuit and third lead wire functions

0	1	2	3	4	6	7	8	9	A	B
	✓	✓	✓							

*Safety approvals

✓	✓		✓	✓	

