

Long Life 24mm Diameter, Single-Turn, Carbon Panel Controls



Features

- Long life 24mm diameter, single-turn industrial panel controls
- Carbon film element
- Single unit, single shaft
- High quality, 2,000,000 cycle rotational life
- Low cost
- Independent linearity, $\pm 3\%$ max.
- Metal shaft and bushing
- Linear taper
- 6mm diameter shafts in slot, flat or round end styles
- Standard 15mm or 20mm shaft length
- Panel mount style
- Right angle ear-lug terminals
- Continuous rotation units available as special order

Specifications

Electrical

Standard Resistance Range	1k Ω to 100k Ω
Resistance Tolerance	$\pm 10\%$ standard
End Resistance	3 Ω max.
Resistance Taper	B = linear
Independent Linearity	$\pm 3\%$ max.
Peak Noise (C.R.V.)	3% max.
Power Rating	0.5 watt at +40°C, 0 watt at +85°C
Maximum Input Voltage	200VDC or power rating, whichever is smaller
Insulation Resistance	100M Ω minimum at 1,000VDC
Dielectric Strength	1,000VAC, 1 minute
Adjustment Travel	280°

Mechanical

Mechanical Travel	300° $\pm 5^\circ$
Shaft Torque	100 gf·cm (1.386 oz·in) max.
Stop Strength	9 kgf·cm (124.76 oz·in) min.
Shaft Strength (push)	125 N (12.75 kgf) min.
Shaft Strength (tensile)	125 N (12.75 kgf) min.
Shaft End Play	$\pm 0.4 \times$ (shaft length/30) mm max.
Mounting Nut Torque	15 kgf·cm (207.94 oz·in) min.
Marking	Model type, taper, resistance code, shaft type, terminal identification, date code

Environmental

Temperature Range	-10°C to +85°C
Temperature Characteristics	+80°C, 5 hours $\Delta T/R \leq \pm 5\%$
Temperature Cycle	-10°C, +80°C, 30 minutes each, 5 cycles $\Delta T/R \leq \pm 10\%$
Load Life	+40°C, 0.5 watt, 1,000 hours $\Delta T/R \leq \pm 10\%$
Moisture and Load Life	+40°C, 90-95% RH, 0.5 watt, 500 hours $\Delta T/R \leq \pm 20\%$
Vibration	10-55Hz, 1.5mm amplitude, 3 directions $\Delta T/R \leq \pm 5\%$
Soldering Heat Resistance	350°C $\pm 5^\circ$ C, 3 seconds $\Delta T/R \leq \pm 2\%$
Rotational Life	2,000,000 cycles without load $\Delta T/R \leq \pm 15\%$

$\Delta T/R$ = Total Resistance Change

Note: A long life panel control should only be used in a circuit as a potentiometer (3-terminal voltage divider).

Unit: mm

RVQ24YN03
Panel Mount, Single Unit, Single Shaft
Right Angle Ear-Lug Terminals

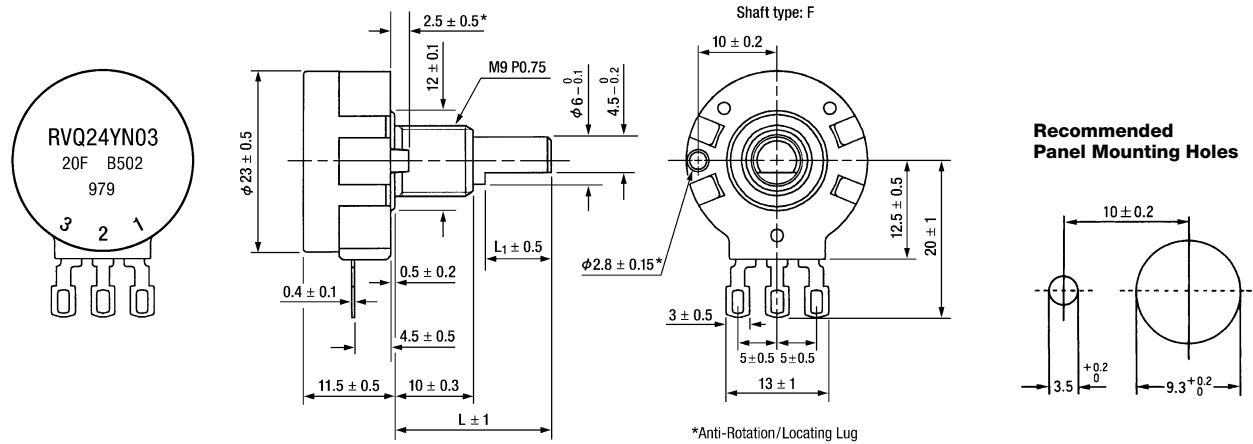

Part Numbering System

RV Q 24 Y N 03 15 S B 104 K

NOTE: FMS = From Mounting Surface

- **Resistance Tolerance: K** = ±10% (standard).
- **Resistance Code:** Expressed in ohms. A three digit code where the first two digits are significant figures, and the third digit indicates the number of zeros that follow these figures (i.e., 100 = 10Ω; 101 = 100Ω; 102 = 1,000Ω; 103 = 10,000Ω; 104 = 100,000Ω). See table for standard resistance values.
- **Resistance Taper: B** = Linear.
- **Shaft End Style: S** = Slotted.
F = Flatted.
R = Round.
- **Standard Shaft Length: 15** = 15mm FMS.
20 = 20mm FMS.
 Up to 50mm shaft length available (special order).
- **Design Type: 03** = Design Variation of 24mm Size.
- **Style: N** = Panel Mount, Single Unit, Single Shaft, Right Angle Ear-Lug Terminals.
- **Operating Temperature Range: Y** = -10°C to +85°C.
- **Size: 24** = 24mm Diameter.
- **Rotational Life: Q** = Long Life, 2,000,000 cycles.
- **TOCOS Series Name: RV** = Carbon Film Element.

Standard Resistance Values and Part Numbering Codes

Standard Nominal Total Resistance Values and Part Numbering Codes

Resistance (Ω)	Code	Resistance (Ω)	Code	Resistance (Ω)	Code
1,000	102	10,000	103	100,000	104
2,000	202	20,000	203		
5,000	502	50,000	503		

Refer to Shaft End Styles Specifications and Hardware Specifications for details and availability.
 For additional information, refer to Guidelines and Precautions for Using Panel Controls.

【高回転寿命形ポテンシオメータ】

200万回転 LIFE : 2,000,000 CYCLES TYPE **RVQ24YN03**

■特徴

FEATURES

- 高性能（回転寿命：200万回、直線性：±3%）でローコスト対応。
- 計測器等、機器のサーボコントロール用の位置、角度検出に最適です。
- 回転角：エンドレス対応可能。
- High quality type（Rotation life：2 million cycles, Independent linearity：±3%Max.） and low-cost type.
- The product will serve as a part most suited to the detection of position and angle of robot and servocontrol of instruments and other equipment.
- The product with endless type rotational angle may be manufactured.

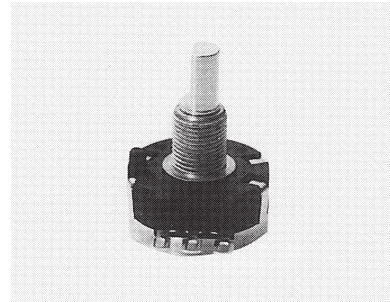

RoHS 指令対応 RoHS compliant

■品名構成

PART NUMBER COMPOSITION

RV Q 24 Y N 03 15 S B 103
 ① ② ③ ④ ⑤ ⑥ ⑦ ⑧ ⑨ ⑩

①種別（炭素系混合体可変抵抗器）

Type : Carbon film type

②高寿命記号

Long Life Type Code

③大きさ Size φ24mm

④使用温度範囲 Operating Temperature range

⑤標準形（1軸1連） Normal Type

⑥品名番号 Type name

⑦シャフト長 Shaft Length

15 : 15mm

⑧シャフト形状 Shaft Type

S : 溝形 Slot

F : 平形 Flat

R : 丸形 Round

⑨抵抗変化特性 Resistance Taper

B : 直線形 Linear

⑩公称全抵抗値（3桁表示）

Nominal total resistance Value Code（3 digits）

103 : 10000Ω

■外形寸法

OUTLINE DIMENSIONS

(Unit : mm)

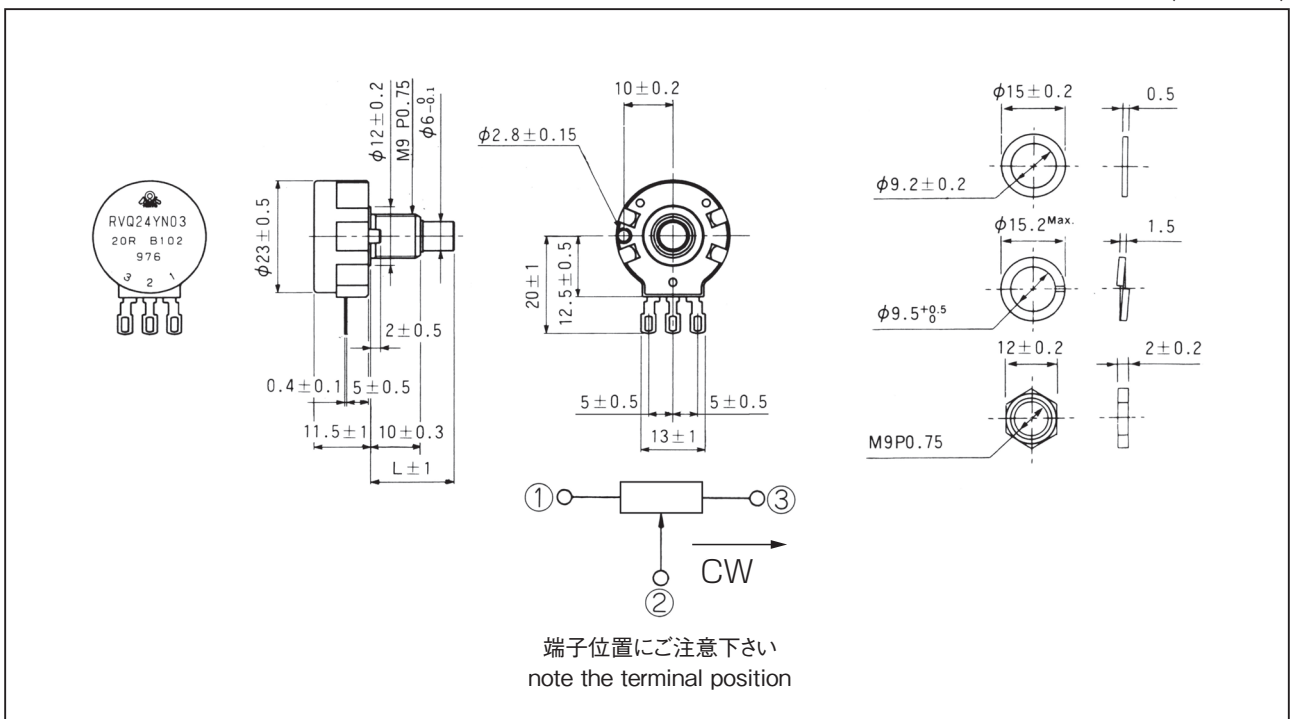

電気的特性

ELECTRICAL CHARACTERISTICS

全抵抗値範囲 Total resistance range	5k Ω , 10k Ω (標準)
全抵抗値許容差 Total resistance tolerance	$\pm 10\%$
残留抵抗値 End resistance	3 Ω 以下 3 Ω Max.
抵抗変化特性 Resistance taper	B (直線型) B (Linear)
摺動雑音 (接触抵抗変化) Contact resistance variation	公称全抵抗値の3%以下 3% Max.
定格電力 Power rating	0.5W/40 $^{\circ}$ C 0W/85 $^{\circ}$ C
最高使用電圧 Max. input voltage	DC200V又は定格電力の小なる方以下 200VDC or power rating, whichever is smaller
電気的有効回転角 Electrical angle	280 $^{\circ}$
絶縁抵抗 Insulation resistance	100M Ω Min./DC 1000V
耐電圧 Dielectric strength	AC 1000V/1 Minute
使用温度範囲 Operating temp. range	-10 $^{\circ}$ C~+85 $^{\circ}$ C
単独直線性 Independent linearity	$\pm 3\%$ Max.

機械的特性

MECHANICAL CHARACTERISTICS

機械的回転角度 Mechanical angle	300 $^{\circ}$ \pm 5 $^{\circ}$
回転トルク Shaft torque	4.9mN \cdot m Max (50gf \cdot cm)
ストップ強度 Stop strength	0.9N \cdot m Min (9kgf \cdot cm Min.)
シャフト強度 (押し強度) Shaft strength (push)	125N Min. (12.75kgf)
シャフト強度 (引っ張り強度) Shaft strength (tensile)	125N Min. (12.75kgf)
シャフト先端の横ガタ Shaft wobble	$\pm 0.4 \times$ (shaft length/30) mm Max.
取付ナット締め付け強度 Bushing nut tightening torque	1.47 N \cdot m Max. (15kgf \cdot cm)

環境特性

ENVIRONMENTAL CHARACTERISTICS

試験項目 Test item	試験条件 Test condition	規格 Standard
はんだ耐熱性 Soldering heat	350 $^{\circ}$ C \pm 5 $^{\circ}$ C, 3 sec.	$\Delta R/R \leq \pm 2\%$
温度特性 Temperature characteristic	+80 $^{\circ}$ C, 5 hours	$\Delta R/R \leq \pm 5\%$
負荷寿命 Load life	+40 $^{\circ}$ C, 0.5W 1,000 hours	$\Delta R/R \leq \pm 10\%$
耐湿負荷寿命 Moisture and load life	+40 $^{\circ}$ C, 90~95%RH 0.5W, 500 hours	$\Delta R/R \leq \pm 20\%$
温度サイクル Temperature cycle	-10 $^{\circ}$ C, +80 $^{\circ}$ C ea. 30 minutes 5 cycles	$\Delta R/R \leq \pm 10\%$
耐振性 Vibration	10~55Hz, 振幅幅 (amplitude) 1.5mm 3 directions	$\Delta R/R \leq \pm 5\%$
回転寿命 Rotation life	2,000,000 cycles, without rating load	$\Delta R/R \leq \pm 15\%$