

Customer: ROXBURGH ELECTRONICS LIMITED

No. SSV96-0304

Date: Jan. 29, 1996

Attention:

Your ref. No:

Your Part. No: 22 6074

SPECIFICATIONS

ALPS:

MODEL RS4511150K

F.E.C. No: 698-040

Sample No. : 6044749M

RECEIPT STATUS

RECEIVED

By. Date

Signature

Name

Title

ALPS ELECTRIC CO., LTD.

HEAD OFFICE
1-7, YUKIGAYA-OHTSUKA-CHO.
OHTA-KU, TOKYO 145 JAPAN

DSG'D Y. Saitoh

APP'D M. Umehara

ENG. DEPT. DIVISION

Sales

SPECIFICATIONS

1. THIS SPECIFICATIONS APPLY TO RS4511114 POTENTIOMETERS.

2. CONTENTS OF THIS SPECIFICATIONS.

4S4512-3c2M, 4S0008-45M
4S0001-200, 4S0001-201
SA518G402A

3. MARKING

• MARKING ON ALL UNITS
DATE CODE, RESIST. VALUE, TAPER, TRADE MARK

Marking ➡ in specifications shows
standard and condition for application

CLASS NO.	TITLE STANDARD TYPE POTENTIOMETER (SLIDE)
-----------	--

ELECTRICAL

1. Overall resistance :

Overall resistance tolerances : $\pm 20\%$ Unit : K Ω

5	10	20	50	100	200	250	500	1,000
---	----	----	----	-----	-----	-----	-----	-------

2. Minimum resistance :

Unit : Ω

Overall resistance (K Ω)	5,10	20,50	100	200, 250	500	1000
Across term.1-2	30	50	100	200	300	500
Across term.2-3	50	70	120	220	320	500

3. Taper : ALPS "B" (SBS49)

4. Rated power : 0.25 Watts.

5. Rated voltage : Rated voltage = $\sqrt{P \cdot R}$ (V)

P : rated power (W)

R : nominal overall resistance (Ω)

When the rated voltage exceeds the maximum operating voltage the maximum operating voltage shall be the rated voltage.

Maximum operating voltage : A.C. 200v , D.C. 10v

6. Dielectric test : Units shall be designed to withstand 300 volts A.C. 50 Hz R.M.S. between resistance elements and case for a period of one minute without damage or arcing.

7. Insulation resistance : Greater than 100 megohms between resistance elements and case when tested by a 250 volts D.C. insulation resistance meter.

8. Sliding lifetest : 15,000 cycles

• Lever shall be operable with speed of 20 mm per sec. without noise by static electricity.

USED ON 45 mm TRAVEL TYPE TONE	NAME RESISTANCE TAPER
ALPS ALPS ELECTRIC CO., LTD. 1-7 YUKIGAYA OTSUKA-CHO OTA-KU TOKYO JAPAN	TITLE SPECIFICATIONS

TAPERED CURVE: ALPS "B"

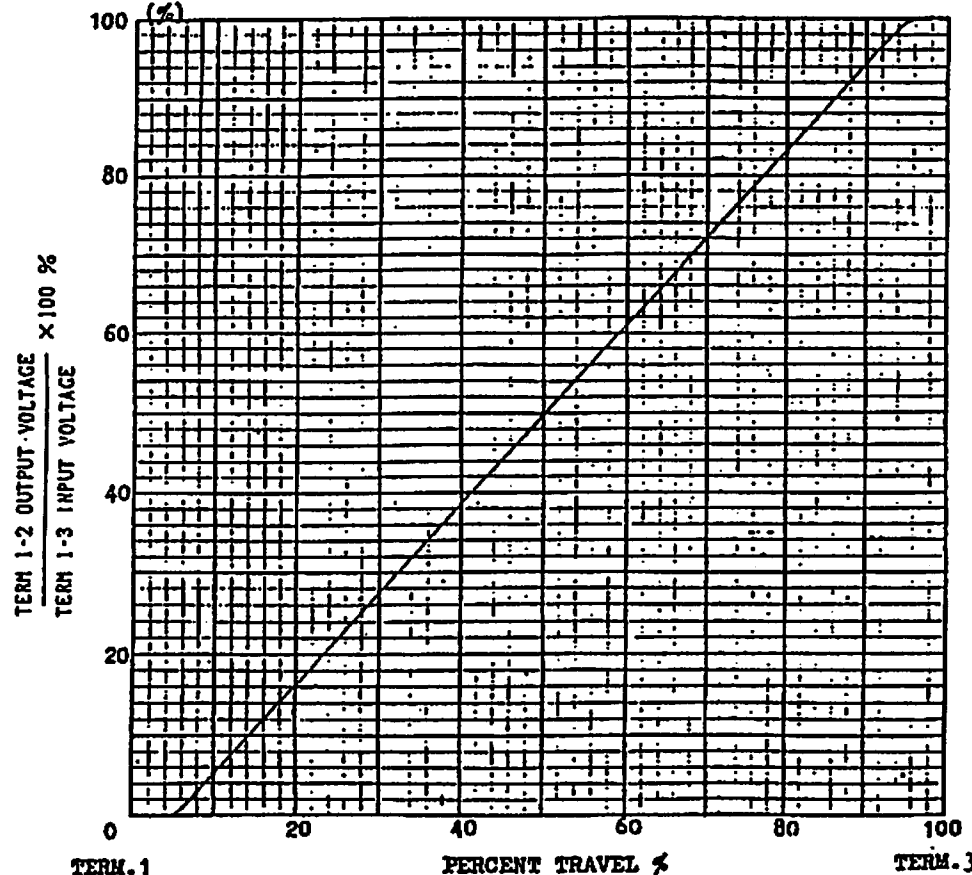

NOTES: PERCENT VOLTAGE CHECK POINT

50% TRAVEL FROM TERM.1

TOLERANCE

40 - 60 %

OR

					ALPS ELECTRIC CO., LTD.		
SYMB	DATE	APPD.	CHKD.	DSGD.	TITLE	SPECIFICATIONS	
					DOCUMENT NO.	4S4518-302M	

SYMB	DATE	APPD.	CHKD.	DSGD.	NAME	RESISTANCE TAPER
					DWG. NO.	SBS49

CLASS.NO.

TITLE
STANDARD TYPE POTENTIOMETER (SLIDE)

MECHANICAL

- Travel : Specified in particular Figure.
- Operating force : 30-250 gf (Note 1)
- Starting force : Operating force + 100 gf max. (Note 1)
(Note 1) Measuring temperature : 5°C - 35°C

Measuring point :

- : 5 mm from lever end (Lever length > 6 mm)
- : 1 mm from lever end (Lever length ≤ 6 mm)
- Sliding speed : 20 mm per sec.

4. Stop strength :

- 5 kgf at a position 5 mm from mounting surface.
(Lever length > 6 mm)
- 5 kgf at a position 2 mm from mounting surface.
(Lever length ≤ 6 mm)

5. Lever lateral play :

When an alternating bending moment of 250 gf.cm is applied perpendicular to the direction of lever travel, the bothside movement of the lever shall be less than $2 (2 \times L / 20)$ mm
L: Lever length on the measurement point from mtg. surface.
(Note 2) Exempt warping of insulated lever.

Lever lateral play



M = 250 gf.cm



L ≤ 5 mm

The bothside movement of the lever shall be less than 1.2 mm

6. Lever strength :

- To be resistant with 5 kgf static force of pull or push applied to lever in thrust direction for 10 seconds without damage.

CLASS.NO.

TITLE
STANDARD TYPE POTENTIOMETER (SLIDE)

- To be resistant with following static force applied to lever in vertical direction to lever driving for 10 seconds without damage.

- 2 kgf.cm over : in case of pot., mounted to chassis with screws.
- 0.5 kgf.cm over : in case of pot., mounted to P.C.B. only with terminals.
- 2 kgf.cm over : in case of pot., mounted to P.C.B. with both terminals and mounting plate.

5 kgf

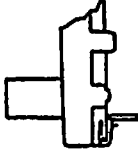

(1)

5 kgf.cm



(2)

7. Lever inclination and twist :

Twist

Inclination 2° max.



2° max.

Inclination

Inclination 2° max.

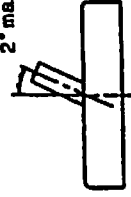

2° max.

8. Resistance to soldering heat : 3 sec. max. at 300°C

ALPS ELECTRIC CO., LTD.

ALPS ELECTRIC CO., LTD.

DATE	APPRO.	CHKD.	DSGD.	TITLE	SPECIFICATIONS
1971.11.10	Shig + 71			Doc. 3 71	DOCUMENT NO. 4S0008-45M (1/2)
DATE	APPRO.	CHKD.	DSGD.	TITLE	SPECIFICATIONS
1971.11.10	Shig + 71			Doc. 3 71	DOCUMENT NO. 4S0008-45M (1/2)

DATE	APPRO.	CHKD.	DSGD.	TITLE	SPECIFICATIONS
1971.11.10	Shig + 71			Doc. 3 71	DOCUMENT NO. 4S0008-45M (1/2)
DATE	APPRO.	CHKD.	DSGD.	TITLE	SPECIFICATIONS
1971.11.10	Shig + 71			Doc. 3 71	DOCUMENT NO. 4S0008-45M (1/2)

ご使用上の注意
PRECAUTION IN USE

1. 偏心ツマミをご使用になる場合
 レハ-の中心より離れたところを作用点としてご使用になる場合、可能な限り
 下図A寸法を短くしてご使用下さい。
 If it will be used the operating point away from the center line of the lever, it should be shorter as possible.
2. レハ-長さについて
 レハ-長さについては、ツマミを含めて、下図B面より極力短いものをご使用願います。レハ-長さについては、作用点までの距離が短いほどしゅう動感が良好となり、長いほど好ましくない感触になります。
 About the length of lever
 If conditions permit, it is advisable to use the shortest possible lever.
 The longer the length up to operating point, the more unfavorable slide feeling will be given.

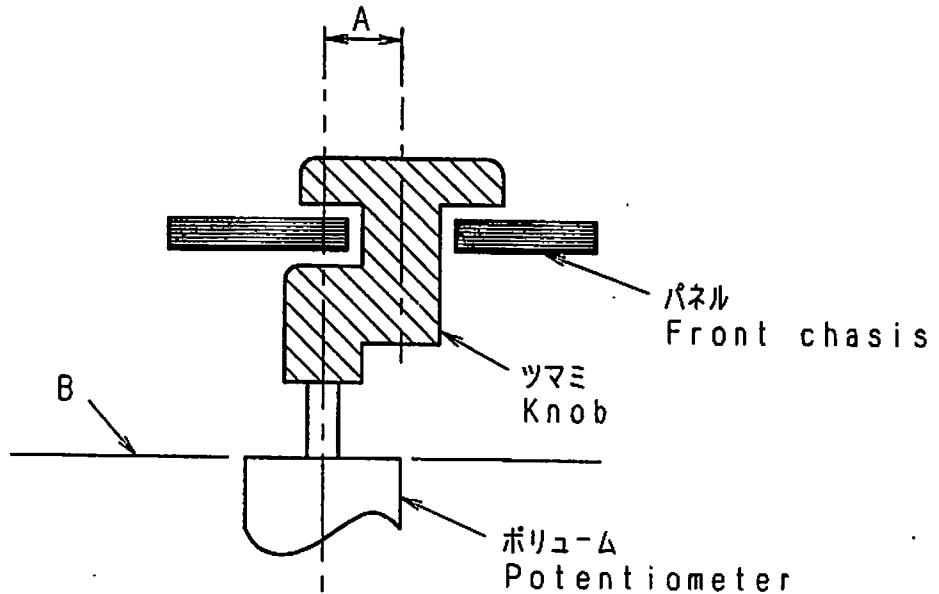

3. レハ-の駆動に関しては上記内容を考慮の上、セット実装を行い
 あらかじめ異常のないことをご確認願います。
 Regarding the operation of the lever, please consider the above mentioned, and make sure nothing is wrong with the operation under installing in your appliance that you plan to use our products actually.
4. ツマミ挿入及びレハ-操作は、ホ-リウムマウント基板に
 ソリ(曲がり)のない状態で行って下さい。
 Knob assembly on the lever and functioning the lever to be performed under the condition of P. C. B. without warp.

					ALPS ELECTRIC CO., LTD.	
			APPD. POI-ENGI '95.7.24 YOSIOKA	CHKD. POI-ENGI '95.7.24 KINURA	DSGD. POI-ENGI '95.7.24 Y. SAITOH	TITLE スライドホ-リウム仕様書 SPECIFICATIONS
ORIGINAL	'91-7-3	Y·Y	K·N	S·A	DOCUMENT NO. 4S0001-200	
SYMB	DATE	APPD	CHKD	DSGD		

はんだ付け条件

FOLLOEW THE NEXT CONDITIONS FOR SOLDERING

1. はんだ SOLDER

JIS Z 3282に規定の63% Snはんだを使用
63% Sn solder specified in JIS Z 3282.

2. 使用基板 BOARD IN USE

両面スルーホール基板又は、片面銅張積層板 板厚 $t=1.6\text{mm}$
Double-faces through-hole board or Single-face
copper laid laminate board.
Plate thickness (t) = 1.6mm

3. 自動はんだ<DIP条件>

- (1) レハ - 位置 センター付近に設定願います。
- (2) フラックス比重 0.83 ± 0.01 (発泡式)
- (3) フラックス高さ フロント基板の板厚の半分の位置にフラックスの上面が接するレベル (図1)
又、ホリウム挿入面への流れ込みのないこと。(フラックス上がり、飛散に注意)
- (4) フロリヒート温度 100°C max. 時間1分以内。(フロント基板のホリウム挿入側の温度)
- (5) はんだ温度 260°C max. 時間5秒以内。 はんだ回数は1回までとする。

IN THE CASE OF DIP SOLDERING

- (1) State of potentiometer
Position a lever in the vicinity of center.
- (2) Specific Gravity of Flux
 0.83 ± 0.01 (foaming type)
- (3) Height of Flux face
A level of the upper face of flux for reaching
the position at a half of the plate thickness
of printed board. (Fig. 1)
Further, no flow of flux invading on the
surface of printed board on the side of
installing potentiometer is allowed.
- (4) Preheat condition
 100°C max., within 1 minute
(Temperature on the side of installing printed
board is designated.)
- (5) Soldering condition
Solder temperature: 260°C max.
Soldering period : within 5 seconds
Time of soldering : only one time is permitted

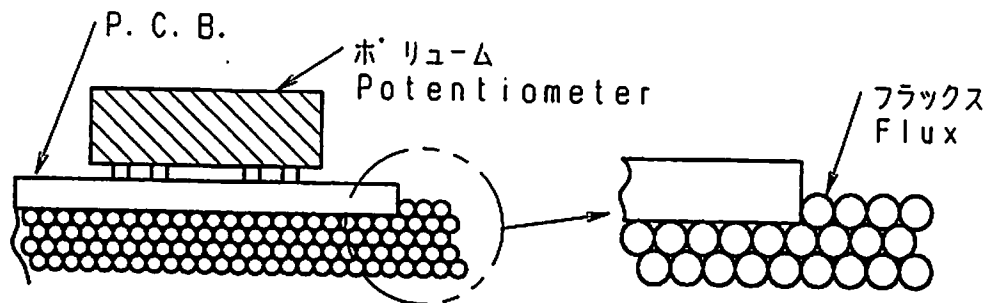

(Fig. 1)

4. 手はんだ IN THE CASE OF MANUAL SOLDERING

はんだ温度 300°C max. 時間3秒以内 はんだ回数は1回までとする。

Solder temperature : 300°C max.

Soldering period : within 3 seconds

Time of soldering : only one time is permitted

					ALPS ALPS ELECTRIC CO., LTD.		
		APPD.	CHKD.	DSGD.	TITLE スライドホリウム仕様書 SPECIFICATIONS 1/2		
		POI-ENGI '95.7.24 YOSIOKA	POI-ENGI '95.7.24 KIMURA	POI-ENGI '95.7.24 Y. SAITO	DOCUMENT NO.		
ORIGINAL	'91-9-3	Y-Y	S-A	S-S	4S0001-201		
SYMB	DATE	APPD	CHKD	DSGD			

5. 注意事項

- (1) はんだ付けの際に、端子にストレスを加えないで下さい。例えば、端子に熱を加えたまま製品を動かしますと、かしめ力、タ及び電気的特性が劣化する恐れがあります。
- (2) 両面スルーホール基板を使用する場合は、ホリウム挿入側の端子取付穴に、はんだランドがないようにご配慮願います。ホリウム挿入側での配線が必要な場合は端子取付穴からの直接取り出しを避けスルーホール配線用の穴を設けるなどのご配慮をお願いします。
- (3) ホリウム挿入側へのはんだ上がりは、はんだ熱による端子接触不良の発生原因となりますので(図2)を参照願います。
- (4) リード配線の場合、ホリウム本体と、はんだ付け部の距離を1mm以上開けてはんだ付け願います。(図3)
- (5) はんだ付けによるホリウムへの影響は、プリント基板の大きさ、ホリウムの取付け位置、はんだ槽の大きさ、等により異なりますのであらかじめ実使用状態で実施し、異常のないことを確認の上、はんだ付けして下さい。

MATTERS TO BE NOTED

- (1) Do not add any stress on terminals in the case of soldering. For instance, forced movement of potentiometer with terminals being heated may probably deteriorate the electric features due to generation of looseness in connection between resistant board and terminals.
- (2) Avoid use of double-faces through-hole board as much as possible. If it is necessary to use it, Do not apply through-hole plating to a hole in which a potentiometer is inserted, and install a land to which terminals are soldered only on a face opposite to the face on the side of installing potentiometer.
- (3) Use caution to soldering process so as to prevent solder from rising up to the surface of printed board on the side of installing potentiometer, because defective contact may take place in terminal connecting part due to soldering heat. (Fig. 2)
- (4) In the case of lead wiring, solder it so that a gap of 1 mm or more may be reserved between the potentiometer body and soldering part. (Fig. 3)
- (5) The grade of influence of soldering exerted on the potentiometer depends upon the size of a printed board, installing position of the potentiometer, and the size of a solder bath etc. Therefore, make sure, in advance, of no abnormal state under the conditions of soldering to be carried out at present.

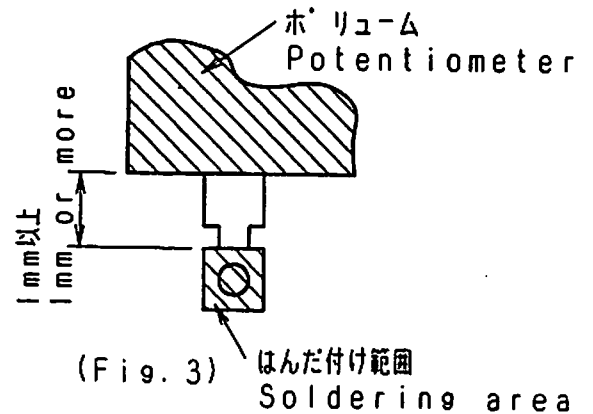
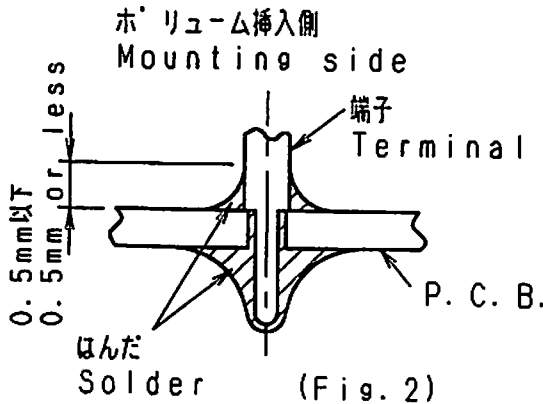

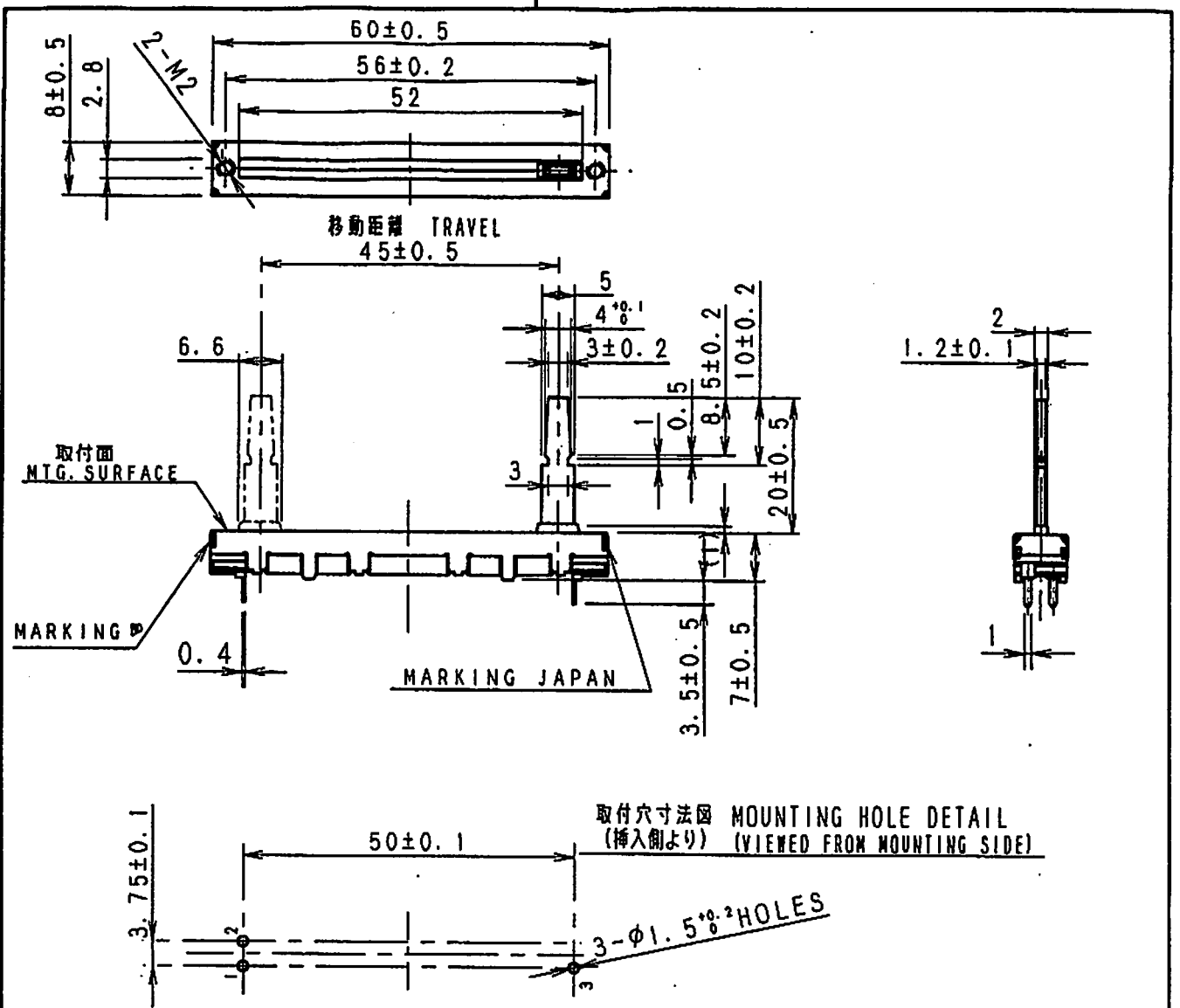

					ALPS ELECTRIC CO., LTD.					
					APPD.	CHKD.	DSGD.	TITLE スライドホリウム仕様書 SPECIFICATIONS 2/2		
					POI-ENGI '95.7.24 YOSIOKA	POI-ENGI '95.7.24 KINURA	POI-ENGI '95.7.24 Y. SAITOH	DOCUMENT NO.		
ORIGINAL	'91-9-3	Y·Y	S·A	S·S						4S0001-201
SYMB	DATE	APPD	CHKD	DSGD						G0444749M



- NOTES
1. MOUNTING SCREW THREAD LENGTH IS CHASSIS THICKNESS +2mmMAX.
取付用ネジの首下長さは、シャーシ板厚 +2mm以下とする。
 2. TOP SIDE OF KNOB SHALL BE MOUNTED TO LEVER WITHIN 30mm LENGTH FROM LEVER MTG. SURFACE.
取付面からつまみ先端まで 30mm以内でご使用願います。

指定なき部分の許容差 TOLERANCES UNLESS OTHERWISE SPEC	
$L \leq 10$	±0.3
$10 < L < 100$	±0.5
$100 \leq L$	±0.8
角度 ANGULAR DIMENSION	±5°

PART NO.	NAME	MATERIAL NAME / CODE	FINISH
 ALPS ELECTRIC CO., LTD.			
		DSGD. 電装 K. SATOU '93-06-16	SCALE 1:1
		CHKD. S. ABE '93-06-16	 TITLE SLIDE POTENTIOMETER SINGLE UNIT
		APPD. Y. YOSHIOKA '93-06-16	UNIT III III
SYMB	DATE	APPD	CHKD
			DSGD
		DOCUMENT NO.	

Standard Type Slide Potentiometer (Super Slide™)

RS□□1 Series

Available in a wide variety; solderable with auto dipping.

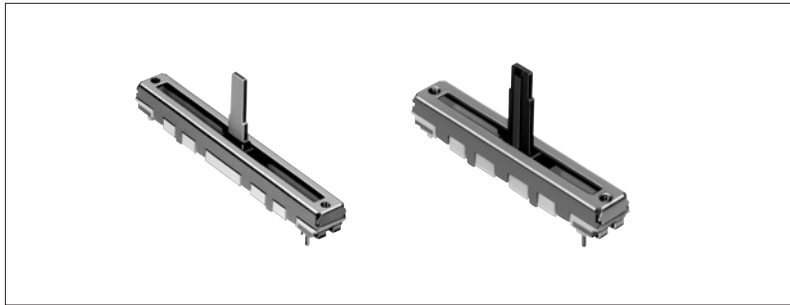

Car Use

Features

- A wide range of products. (stroke length : 15, 20, 25, 30, 45, 60mm)

Applications

- Contrast control for LCD monitors
- Controls for mixers, mini component stereos and electronic instruments
- Controls for accessories, including heaters, dimmers and wipers in vehicle cabins
- Controls for interphones, fan-heaters and electric carpets

Typical Specifications

Items	Specifications
Total resistance tolerance	±20%
Maximum operating voltage	50V AC, 10V DC
Operating force	0.3 to 2.5 N
Operating life	15,000 cycles
Operating temperature range	-25°C to +70°C

Rotary Potentiometers

Slide Potentiometers

Trimmer Potentiometers

Multi Control Devices

Position Sensors

General-use

Mixer

Recommended Products List

Insulated lever

Number of resistor elements	Travel (mm)	Products No.	Lever types	Length of lever (mm)	Total resistance (kΩ)	Resistance taper	Detent	Mounting plate	Minimum packing unit (pcs.)	Drawing No.
Single-unit	30	RS301111J00P	J-1	5	10	15A	Without	Without	100	1
		RS30111AJ01R				1B		With		2
		RS301111J00R			50	Without		1		
		RS301111J00W				15A		With		2
	RS30111AJ01K	A	10	10	1B	Without		Without		3
	RS301111A01G	C				Without		4		
	RS301111C01L					5				
	RS30111AC00V	6								
45	RS45111ABA02	B	5	10	1B	Without	With	7		
30	RS30112AC00J	C					8			
Dual-unit	30	RS30112AJA02	J-1	5	3B					

Metal lever

Number of resistor elements	Travel (mm)	Products No.	Lever types	Length of lever (mm)	Total resistance (kΩ)	Resistance taper	Detent	Mounting plate	Minimum packing unit (pcs.)	Drawing No.		
Single-unit	15	RS15111A900B	9-1	10	10	15A	Without	With	100	9		
	30	RS30111A9012						Without		10		
		RS3011114A02	4	15	20	1B		Without		11		
		RS30111A602N	6					With		12		
	45	RS45111A900F	9-1	10	10	15A		Without		13		
		RS4511119A04						Without		14		
	60	RS6011YA600M	6	15	10	10		Without		With	15	
		RS6011Y19004	9-1					10		1B	Without	16
		RS6011Y1600Q	6					15				Without
	Dual-unit	45	RS451121400A	4	20	20		15A		Without	Without	100
RS45112A400G			19									
60		RS60112A600N	6	15	10	15A	With	20				
		RS60112A600U										

Note

Additional product specifications not included in the above list are also available.

For product specifications, see P.99
 For other detailed specifications, see P.99
 For details of lever types, see P.128, 129

Product Specifications

In addition to the recommended products, the following specifications can also be accommodated.

Standard Type Slide Potentiometers (Super Slide™) Specifications

Type	Travel (mm)	Model	Center detent	For DC use	Mounting plate
Single-unit	15	RS15111	Available	10V DC	Available
	20	RS20111			
	25	RS25111			
	30	RS30111			
	45	RS45111			
60	RS6011Y				
Dual-unit	15	RS15112		10V DC Not available with tap	
	20	RS20112			
	25	RS25112			
	30	RS30112			
	45	RS45112			
60	RS60112				

Rotary Potentiometers
Slide Potentiometers
Trimmer Potentiometers
Multi Control Devices
Position Sensors

Electrical Characteristics

Total resistance (kΩ)	10	20	50	100	200
Total resistance tolerance	±20%				
Resistance taper	1B	4B	10A	15A	

General-use
Mixer

Lever shape and dimensions

Metal lever		Insulated lever	
Code	Dimensions	Code	Dimensions
9-2		J-1	
9-1		A	
6		C	
4			

Corresponding specifications

Resistance taper	3B, 15C	Lever type	
		B	D (Marker colour tone: White, Red)
Dust cover	Available		
Tap	Available (Only the center-positioned)		

For resistance taper, see P.100

Orders other than recommended products

Specify orders for varieties that are not listed in the Recommended Product List, referring to the following example.

Sample part number



Specify the travel distance by symbol

Travel (mm)	Code	Travel (mm)	Code
15	15	30	30
20	20	45	45
25	25	60	60

Number of resistor elements

Single	1 (Enter "Y" for 60 mm travel)
Dual	2

Lever type / Length of operation unit (mm)

Insulated lever

Code	Configuration	Length
J1	J-1	5
0A	A	10
		15
0C	C	10
		15
0B	B	10
		15

Metal lever

Code	Configuration	Length
91	9-1	10
92	9-2	5
04	4	15
		20
06	6	15
		20

Marker type

Code	Style	Color	Length
DR	D	Red	10
DW		White	15

Length of operation unit

If the length is less than 10 mm, add a "0" before the number. (e.x., 5 mm length = "05")

Detent

Code	Detent
C0	Without
C1	Center

Mounting plate

Code	Mounting plate
P0	Without
P1	With

Total resistance

Code	Total resistance (kΩ)	Code	Total resistance (kΩ)
103	10	104	100
203	20	204	200
503	50		

Resistance taper

Code	Resistance taper
A	15A
B	1B
D	10A
W	4B
V	3B
C	15C

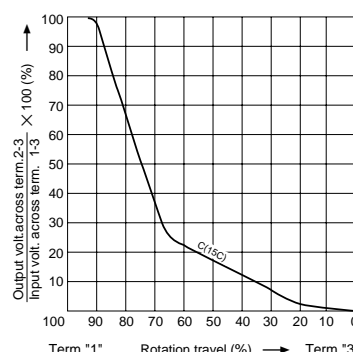
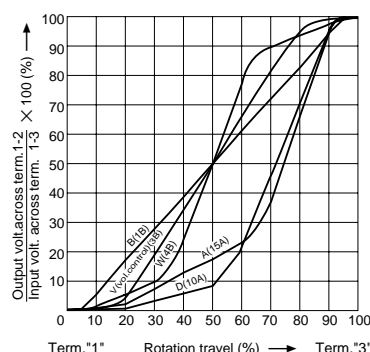

Note

Shows the specification recommended by us.

Dimensions

Unit : mm

No.	Style	PC board mounting hole dimensions
1		
2		
3		
4		

The length of the operating part (L1) can be customized. See P.100

Dimensions

Unit : mm

No.	Style	PC board mounting hole dimensions
5		
6		
7		
8		

The length of the operating part (L1) can be customized. See P.100

Rotary Potentiometers
Slide Potentiometers
 Trimmer Potentiometers
 Multi Control Devices
 Position Sensors

General-use
Mixer

Dimensions

Unit : mm

No.	Style	PC board mounting hole dimensions
9		
10		
11		
12		

The length of the operating part (L1) can be customized. See P.100

Dimensions

Unit : mm

No.	Style	PC board mounting hole dimensions
13		
14		
15		
16		

The length of the operating part (L1) can be customized. See P.100

Rotary Potentiometers
Slide Potentiometers
 Trimmer Potentiometers
 Multi Control Devices
 Position Sensors

General-use
Mixer

Dimensions

Unit : mm

No.	Style	PC board mounting hole dimensions
17		
18		
19		
20		

The length of the operating part (L1) can be customized. See P.100

Products Specifications

Type	Standard type	Miniature type	Slim type
Model	RS□□11□	RS10F1□	RS□□H1□ RS□□M11

Mechanical Characteristics

Operating temperature range		-25 °C to +70 °C		
Solder heat resistance	Manual soldering	Lower than 350°C for less than 3 seconds		
	Dip soldering	Lower than 260°C for less than 5 seconds		
Operating force		0.3 to 2.5N	0.5 to 3.5N	0.2 to 1.1N RS□□M : 0.15 to 0.8N
Stopper strength		50N	Lever style A : 25N J : 40N	30N
Lever push-pull strength			25N	30N RS□□M11 : 20N
Lever wobble (mm)		$\frac{2(2 \times L)}{20}$ (Both sides)	$\frac{2(2 \times L)}{25}$ (Both sides)	1.6 max. Both sides
Detent slip-out force		0.2 to 2N	0.15 to 2N	0.05 to 0.8N RS□□M11 : with click feeling
Lever deviation (mm)		0.5 max. (One side)		
Solderability		230±5°C、3±0.5s		

Electrical Characteristics

Total resistance (kΩ)	10, 20, 50, 100, 200	10, 20, 50, 100	10, 20, 50, 100, 200
Total resistance tolerance	±20%		
Resistance taper	15A, 1B, 4B, 10A, (3B, 15C)	1B, 4B	15A, 1B, 3B

Endurance

Sliding life	15,000 cycles	5,000 cycles	10,000 cycles
--------------	---------------	--------------	---------------

Environmental test

Cold	-25°C for 96h
Long-term heat resistance	+70°C for 96h
Moisture resistance	+40°C, 90 to 95 % RH for 96h

Notes

- "L" in the "Lever Wobble" column of the above table indicates the length of lever.
- Specifications other than those listed above can be customized.
- The resistance law specification in () varies individually.