



Features

- Bushing mount
- Excellent resolution
- High rotational life
- Non-standard features and specifications available

BOURNS®

6637 - Precision Potentiometer

Electrical Characteristics¹

Standard Resistance Range	1 K to 100 K ohms
Total Resistance Tolerance	±10 %
Independent Linearity	±1 %
Effective Electrical Angle	340° ±3°
End Voltage	0.5 % maximum
Output Smoothness	0.1 % maximum
Dielectric Withstanding Voltage (MIL-STD-202, Method 301)	
Sea Level	750 VAC minimum
Power Rating (Voltage Limited By Power Dissipation or 300 VAC, Whichever is Less)	
+70 °C	1 watt
+125 °C	0 watt
Insulation Resistance (500 VDC)	1,000 megohms minimum
Resolution	Essentially infinite

Environmental Characteristics¹

Operating Temperature Range	+1 °C to +125 °C
Storage Temperature Range	-65 °C to +125 °C
Temperature Coefficient Over Storage Temperature Range	±500 ppm/°C maximum
Vibration	15 G
Wiper Bounce	0.1 millisecond maximum
Total Resistance Shift	±5 % maximum
Voltage Ratio Shift	±0.5 % maximum
Shock	50 G
Wiper Bounce	0.1 millisecond maximum
Total Resistance Shift	±5 % maximum
Voltage Ratio Shift	±0.5 % maximum
Load Life	1,000 hours, 1 watt
Total Resistance Shift	±10 % maximum
Rotational Life (No Load)	10,000,000 shaft revolutions
Total Resistance Shift	±10 % maximum
Moisture Resistance (MIL-STD-202, Method 106)	
Total Resistance Shift	±15 % maximum
IP Rating	IP 40

Mechanical Characteristics¹

Mechanical Angle	Continuous
Torque (Starting & Running)	0.40 N-cm (0.5 oz.-in.) maximum
Mounting	170-200 N-cm (15-18 lb.-in.) maximum
Shaft Runout	0.025 mm (0.001 in.) T.I.R.
Shaft End Play	0.13 mm (0.005 in.) T.I.R.
Shaft Radial Play	0.13 mm (0.005 in.) T.I.R.
Backlash	0.1 ° maximum
Weight	16 gm
Terminals	Rear turret type
Soldering Condition	Recommended hand soldering using Sn95/Ag5 no clean solder, 0.025 " wire diameter. Maximum temperature 399 °C (750 °F) for 3 seconds. No wash process to be used with no clean flux.
Marking	Manufacturer's name and part number, resistance value and tolerance, linearity tolerance, wiring diagram, and date code.
Ganging (Multiple Section Potentiometers)	1 up maximum
Hardware	One lockwasher (H-37-2) and one mounting nut (H-38-2) is shipped with each potentiometer.

¹At room ambient: +25 °C nominal and 50 % relative humidity, except as noted.

Recommended Part Numbers

Part Numbers	Resistance (Ω)
6637S-1-102	1,000
6637S-1-502	5,000
6637S-1-103	10,000

BOLDFACE LISTINGS ARE IN STOCK AND READILY AVAILABLE THROUGH DISTRIBUTION.

FOR OTHER OPTIONS CONSULT FACTORY.

Product Dimensions

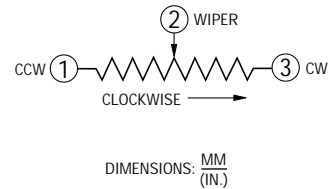
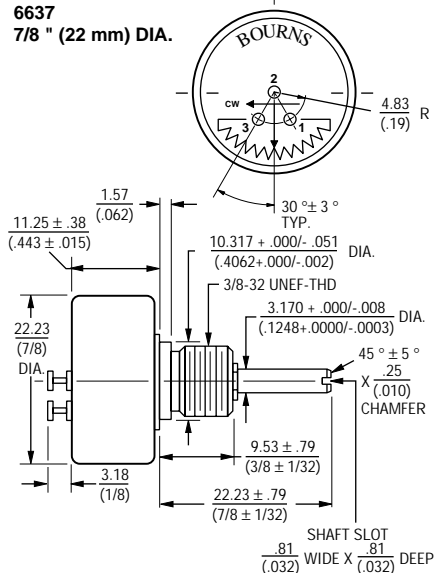



7/8", 1 5/16" ϕ SINGLE TURN BUSHING- OR SERVO MOUNT POTENTIOMETERS CONDUCTIVE PLASTIC ELEMENT

- Infinite resolution element
- Standard linearity: 1.0%
- Extended temperature range: -65°C to $+125^{\circ}\text{C}$
- Output smoothness: 0.1% standard
- Custom design capability available
- Molded-in rear terminals

STANDARD SPECIFICATIONS	7/8" ϕ MODEL 6537 MODEL 6637	7/8" ϕ MODEL 6538 MODEL 6638	1 5/16" ϕ MODEL 6657
Servo Mount			
Bushing Mount			
Electrical Characteristics			
Resistance Range	1 K Ω to 100 K Ω		
Resistance Tolerance	$\pm 10\%$		
Linearity (Independent)	$\pm 1.0\%$		
Resolution	Essentially infinite		
Effective Electrical Angle	$340^{\circ} \pm 3^{\circ}$		
End Voltage	0,5% max.		
Output Smoothness	0,1%		
Power Rating	70 $^{\circ}\text{C}$ 1,0 W	1,0 W	1,5 W
	125 $^{\circ}\text{C}$	0 W	
Dielectric Strength	Sea Level	750 V~ min.	
Insulation Resistance	500 V =	500 Meg. Ω min.	1000 Meg. Ω min.
Environmental Characteristics			
Operating Temperature Range	-65°C to $+125^{\circ}\text{C}$		
Vibration	15 G		
Wiper Bounce	0.1 millisecond max.		
Shock	50 G		
Wiper Bounce	0.1 millisecond max.		
Mechanical and Physical Characteristics			
Mechanical Angle	Continuous		
Shaft Runout	0.005 in. T. I. R.	0.001 in. T. I. R.	0.001 in. T. I. R.
Shaft End Play	0.005 in. T. I. R.		
Shaft Radial Play	0.005 in. T. I. R.	0.003 in. T. I. R.	0.003 in. T. I. R.
Backlash	0.1 $^{\circ}$ max.		
Pilot Diameter Runout (Servo)	0.0025 in. T. I. R.	0.0025 in. T. I. R.	—
Lateral Runout (Servo)	0,003 in. T. I. R.	0.003 in. T. I. R.	—
Rotational Life, shaft revolutions	10,000,000	20,000,000	10,000,000
Torque, Starting and Running	0.5 oz.-in. max.	0.25 oz.-in. max.	0.5 oz.-in. max.
Terminals	Rear turret type		
Ball Bearings	—	Front and rear	—
Markings	Manufacturer's name and part number, resistance value and tolerance, linearity tolerance, wiring diagram, date code.		

Specifications are subject to change without notice.

ORDERING INFORMATION

Resistance Ω	7/8" Servo Mount		7/8" Bushing Mount		15/16" Bushing Mount
1,000	● 6537S-1-102	● 6538S-1-102	● 6637S-1-102	● 6638S-1-102	● 6657S-1-102
2,000	6537S-1-202	6538S-1-202	6637S-1-202	6638S-1-202	6657S-1-202
5,000	● 6537S-1-502	6538S-1-502	● 6637S-1-502	6638S-1-502	● 6657S-1-502
10,000	● 6537S-1-103	● 6538S-1-103	● 6637S-1-103	● 6638S-1-103	● 6657S-1-103
20,000	6537S-1-203	6538S-1-203	6637S-1-203	6638S-1-203	6657S-1-203
50,000	6537S-1-503	6538S-1-503	6637S-1-503	6638S-1-503	6657S-1-503
100,000	6537S-1-104	6538S-1-104	6637S-1-104	6638S-1-104	6657S-1-104

The last three digits of the part number represent the resistance in standard code.

● Preferred resistance values

DIMENSIONS (INCH)

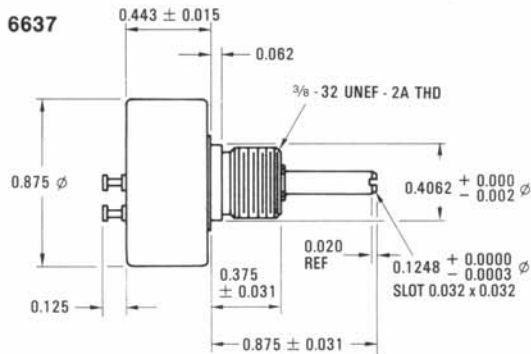

6637S-004 = same shaft as 6657

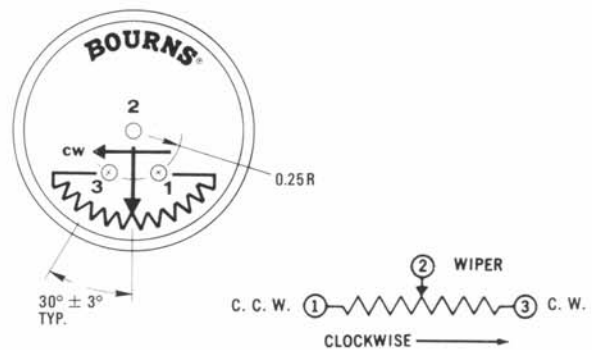
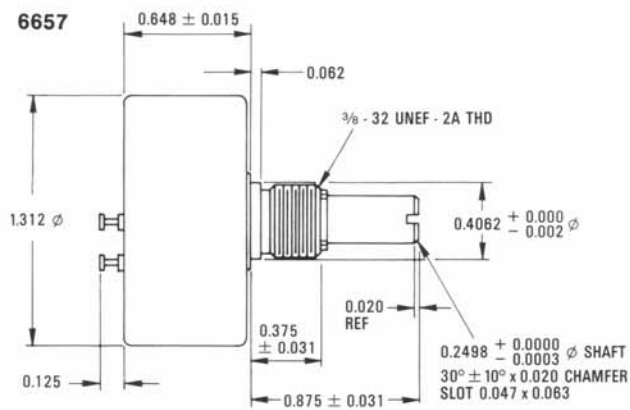
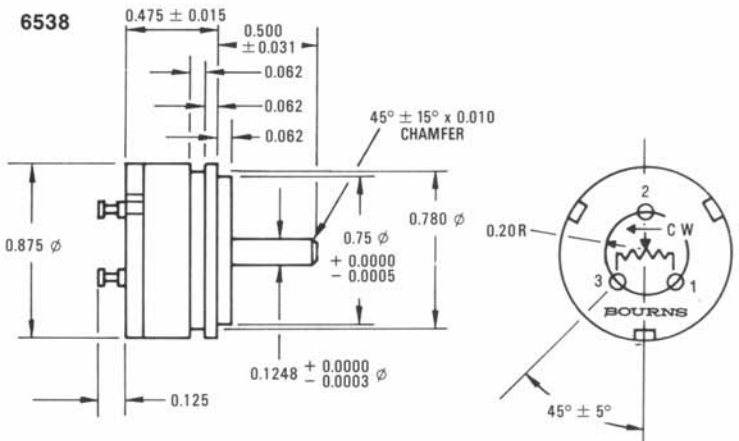
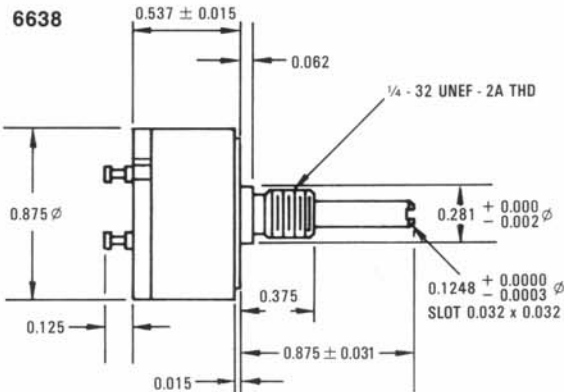
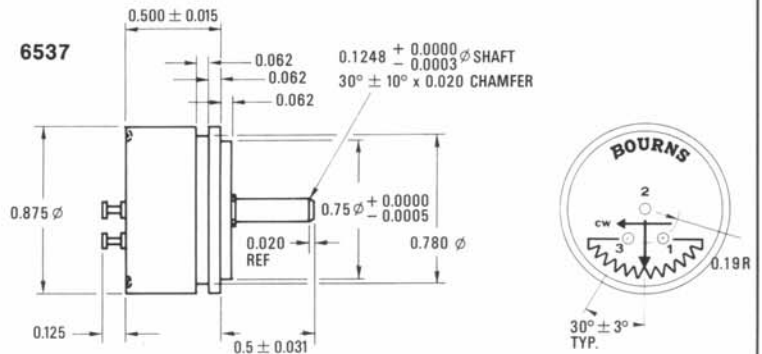

Specifications are subject to change without notice.



Features

- Bushing mount
- Excellent resolution
- High rotational life
- Non-standard features and specifications available

6637 - Precision Potentiometer

Electrical Characteristics¹

Standard Resistance Range 1K to 100K ohms
 1K to 100K ohms
 Resistance Tolerance ±10%
 Independent Linearity ±1%
 Effective Electrical Angle 340° + 3°
 End Voltage 0.5% maximum
 Output Smoothness 0.1% maximum
 Resolution Essentially infinite
 Power Rating (Voltage Limited
 By Power Dissipation or
 300 VAC, Whichever is Less)
 +70°C 1 watt
 +125°C 0 watt
 Dielectric Withstanding Voltage
 MIL-STD-202, Method 301
 Sea Level 750 VAC minimum
 Insulation Resistance
 (500 VDC) 1,000 megohms minimum

Environmental Characteristics¹

Operating Temperature
 Static Operation Temp Range
 -65°C to +125°C
 Dynamic Temp Range
 +1°C to +125°C
 Temperature Coefficient
 ±500ppm/°C maximum
 Moisture Resistance
 MIL-STD-202, Method 106
 Total Resistance Shift
 ±10% maximum
 Vibration 15G
 Wiper Bounce
 0.1 millisecond maximum
 Total Resistance Shift ... ±5% maximum
 Voltage Ratio Shift ±0.5% maximum
 Shock 50G
 Wiper Bounce
 0.1 millisecond maximum
 Total Resistance Shift ... ±5% maximum
 Voltage Ratio Shift ±0.5% maximum
 Rotational Life (No Load)
 10,000,000 shaft revolutions
 Total Resistance Shift
 ±10% maximum
 Load Life 1,000 hours, 1 watt
 Total Resistance Shift .±10% maximum

¹At room ambient: +25°C nominal and 50% relative humidity nominal, except as noted.

Mechanical Characteristics¹

Mechanical Angle Continuous
 Backlash 0.1° maximum
 Shaft Runout
 0.001 in. (0.025mm) T.I.R.
 Shaft End Play
 0.005 in. (0.13mm) T.I.R.
 Shaft Radial Play
 0.005 in. (0.13mm) T.I.R.
 Torque (Starting & Running)
 0.5 oz.-in. (0.40 Ncm) max.

Recommended Part Numbers

Part Numbers	Resistance (W)
6637S-1-102	1,000
6637S-1-502	5,000
6637S-1-103	10,000

BOLD-FACE LISTINGS ARE IN STOCK AND READILY AVAILABLE THROUGH DISTRIBUTION.

FOR OTHER OPTIONS CONSULT FACTORY.

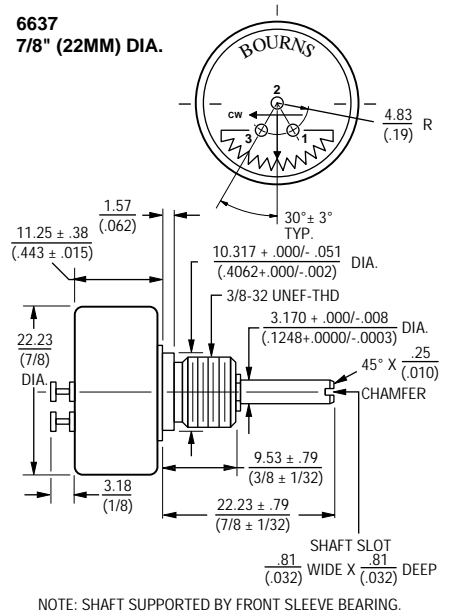

NOTE: SHAFT SUPPORTED BY FRONT SLEEVE BEARING.

