

Model P160
 16mm Rotary Potentiometer
 Conductive Plastic Element
 100,000 Cycle Life
 Metal shaft / Bushing
 Multi - Ganged available
 RoHS Compliant



MODEL STYLES

Side Adjust , Solder Lugs	P160KNP
Side Adjust , PC pins	P160KN
Side Adjust , PC Pins, Long pins	P160KN2
Rear Adjust, PC pins	P160KNPD

ELECTRICAL¹

Resistance Range, Ohms	500-1M
Standard Resistance Tolerance	± 20%
Residual Resistance	20 ohms max.
Power rating Input Voltage, maximum	200 Vac max.
Power Rated, Watts	0.2W- B taper, 0.1W-others
Dielectric Strength	500Vac, 1 minute
Insulation Resistance, Minimum	100M ohms at 250Vdc
Sliding Noise	100mV max.
Actual Electrical Travel, Nominal	260°

MECHANICAL

Total Mechanical Travel	300°± 10°
Static Stop Strength	90 oz-in
Rotational Torque	0.5 to 1.25 oz-in

ENVIRONMENTAL

Operating Temperature Range	-20°C to +70°C
Rotational Life	100,000 cycles

¹ Specifications subject to change without notice.

Model P160

ORDERING INFORMATION²

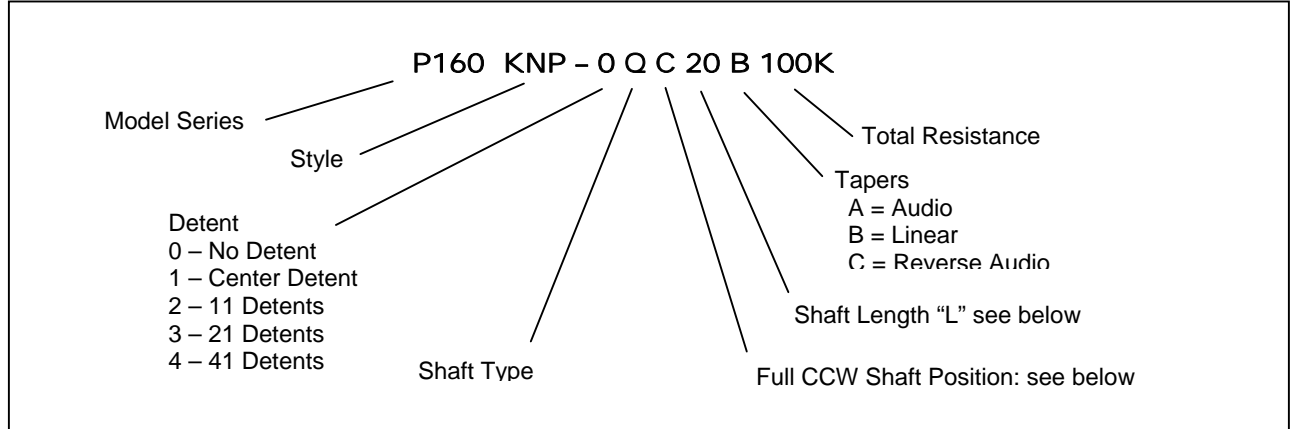

Shaft Types

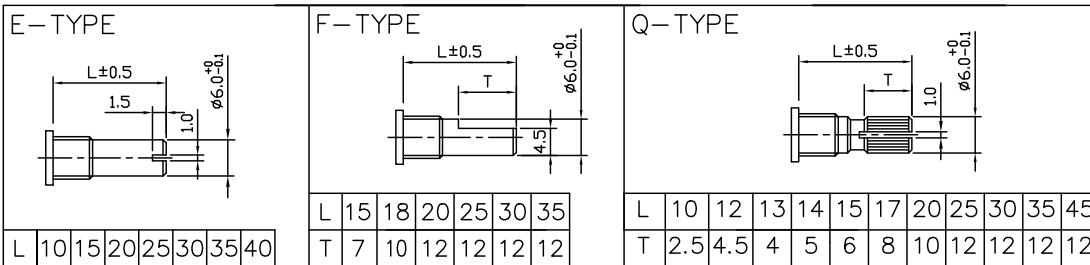

Shaft Position (F-Type Shaft)

Dashed lines on Type "C" and Type "A" shows position of adjustment slot for E-Type and Q-Type shafts

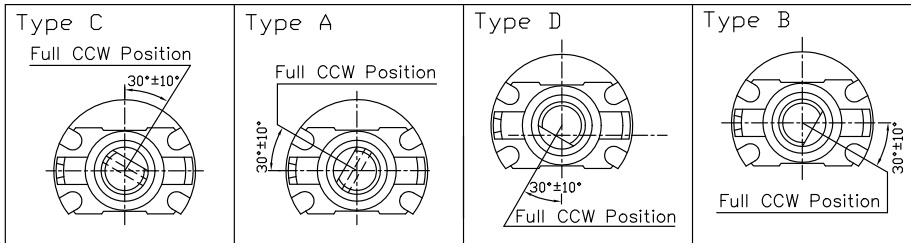

STANDARD RESISTANCE VALUES, OHMS

500 1K 2K 5K 10K 20K 50K 100K 200K 500K 1MEG

CIRCUIT DIAGRAM

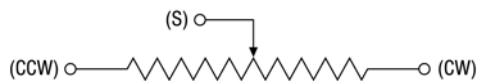

Model P160

OUTLINE DRAWING

Model P160KNP (Side Adjust , Solder Lugs)

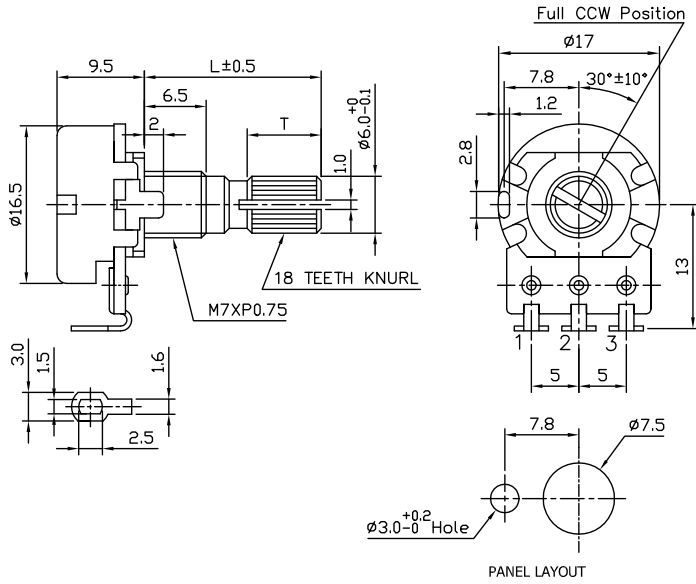

Model P160KN (Side Adjust , PC pins)

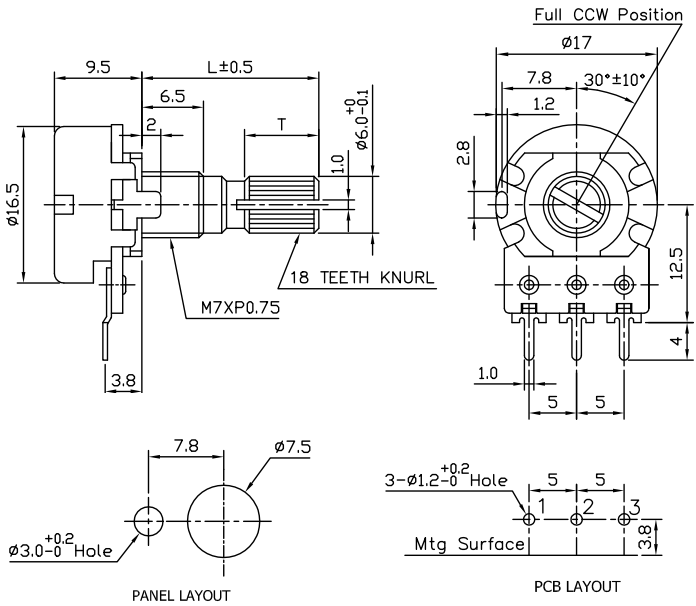

² Contact our customer service for custom designs and features.

Model P160

Model P160KN2 (Side Adjust , PC Pins, Long pins)

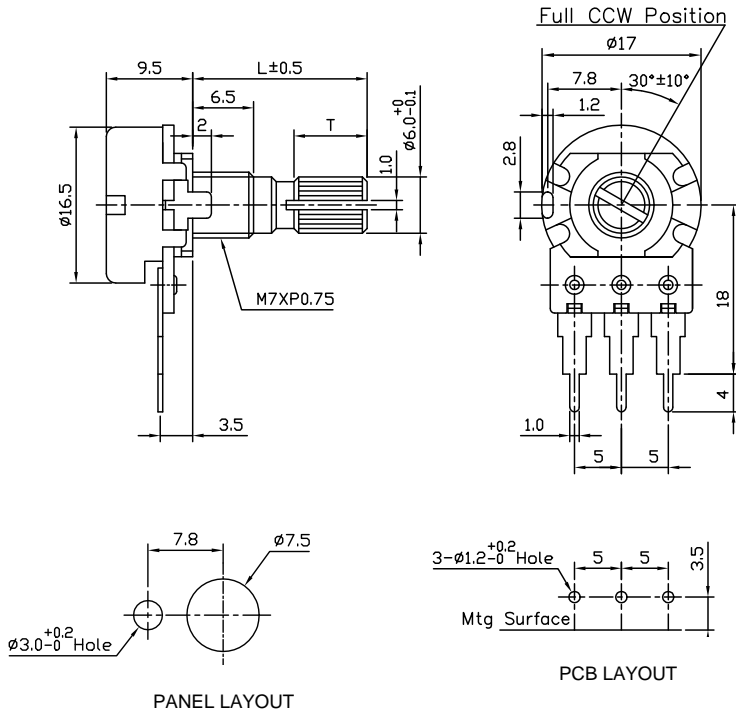

Model P160KNPD (Rear Adjust , PC Pins)

