

Photologic® Slotted Optical Switches Types OPB480, OPB490 Series

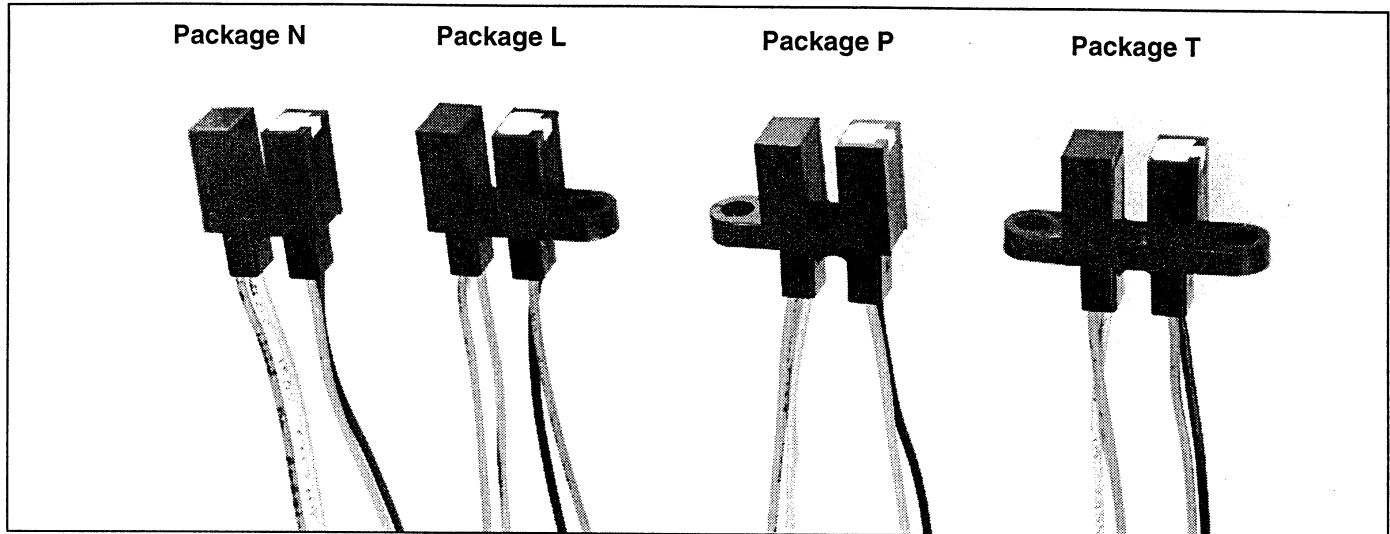

Features

- Choice of mounting configuration
- Choice of aperture
- Choice of output configuration
- Choice of opaque or IR transmissive shell material
- Data rates to 250 kBaud
- 24" min 26AWG wire leads
- Low power consumption

Description

The OPB480 and OPB490 series of Photologic® Photo Integrated Circuit Switches provide optimum flexibility for the design engineer. Building from a standard housing with a 0.125" (3.18 mm) wide slot, the user can specify (1) type and polarity of TTL output, (2) discrete shell material, (3) aperture width, and (4) choice of mounting configuration. These devices exhibit stable performance over supply voltages ranging from 4.5 V to 16.0 V and may be specified as buffered or inverted with 10 kW pull-up or open collector output. All are TTI/LSTTL compatible and can drive up to 10 TTL loads.

Replaces/Upgrades

OPB980, OPB990 series

Absolute Maximum Ratings (T_A = 25° C unless otherwise noted)

Supply Voltage, V _{CC} (Not to exceed 3 sec.)	18 V
Storage Temperature Range	-40° C to +80° C
Operating Temperature Range	-40° C to +80° C
Input Diode Power Dissipation	100 mW ⁽¹⁾
Output Photologic® Power Dissipation	90 mW ⁽²⁾
Total Device Power Dissipation	190 mW ⁽³⁾
Voltage at Output Lead (Open Collector Output)	35 V
Diode Forward D.C. Current	40 mA
Diode Reverse D.C. Voltage	2 V

Notes:

- (1) Derate linearly 1.82 mW/° C above 25° C.
- (2) Derate linearly 1.64 mW/° C above 25° C.
- (3) Derate linearly 3.45 mW/° C above 25° C.
- (4) The OPB980/OPB990 series of switches are terminated with 24 inches of 7 strand 26 AWG, UL 1429 insulated wire on each terminal. Insulation colors and functions are:

RED - IRED Anode	WHITE - V _{CC}
BLACK - IRED Cathode	BLUE - Output
	GREEN - Ground

Other wire lengths and/or colors in addition to customer selected connectors are available. Contact your local representative or call the factory.

- (5) Normal application would be with light source blocked, simulated by I_F = 0mA.
- (6) All parameters tested using pulse techniques.

Housing

All housings are an opaque grade of injection-molded plastic to minimize the assembly's sensitivity to ambient radiation, both visible and near-infrared. Discrete shells (exposed on the parallel faces inside the device throat) are either IR transmissive plastic for applications where aperture contamination may occur or opaque plastic for maximum protection against ambient light.

Types OPB480, OPB490 Series

Package T

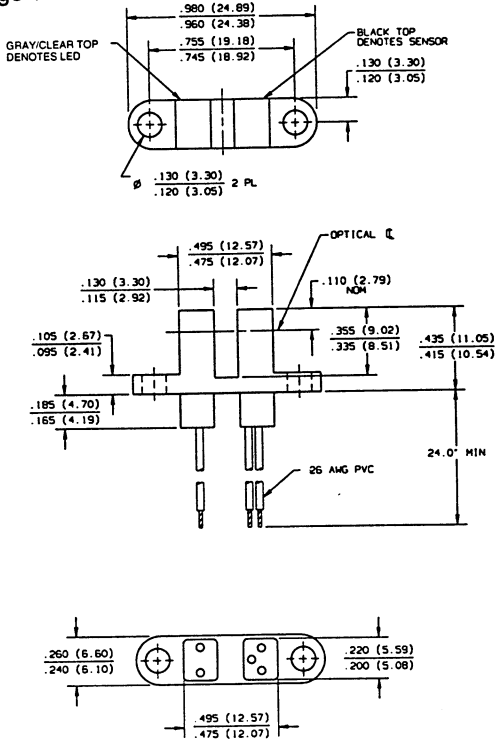

DIMENSIONS ARE IN INCHES (MILLIMETERS)

Package N

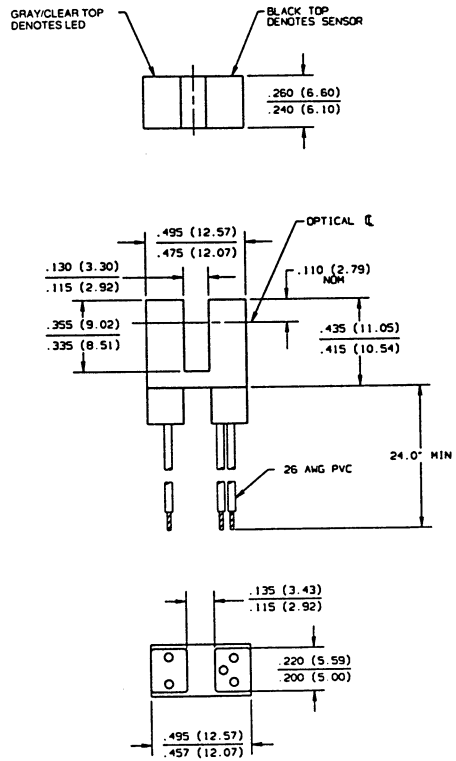

DIMENSIONS ARE IN INCHES (MILLIMETERS)

SLOTTED OPTICAL SWITCHES

Package L

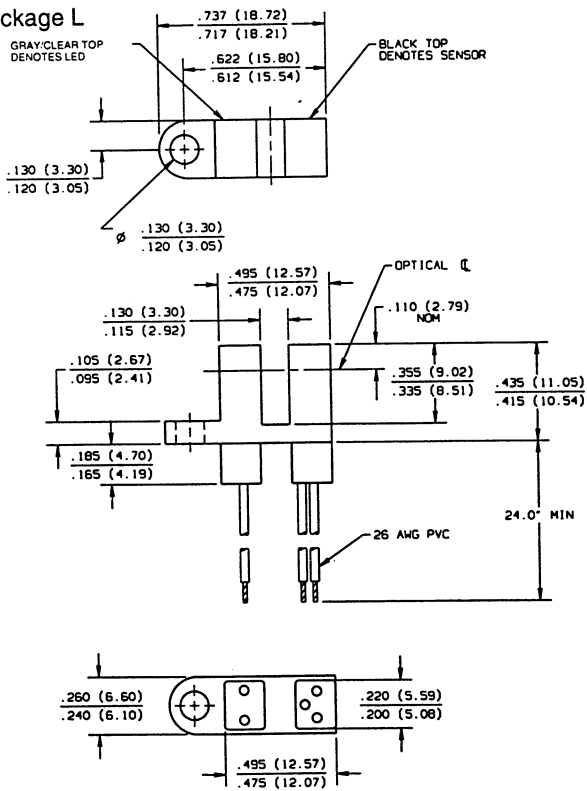

DIMENSIONS ARE IN INCHES (MILLIMETERS)

Package P

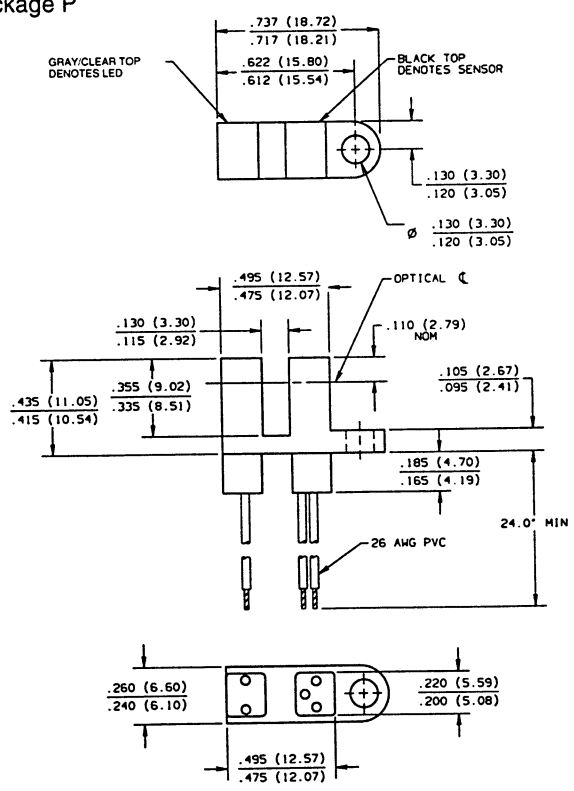

DIMENSIONS ARE IN INCHES (MILLIMETERS)

Types OPB480, OPB490 "55" Series



Electrical Characteristics ($T_A = -40^\circ\text{C}$ to $+80^\circ\text{C}$ unless otherwise noted)

SYMBOL	PARAMETER	MIN	TYP	MAX	UNITS	TEST CONDITIONS
Input Diode						
V_F	Forward Voltage			1.7	V	$I_F = 20\text{ mA}$, $T_A = 25^\circ\text{C}$
I_R	Reverse Current			100	μA	$V_R = 2\text{ V}$, $T_A = 25^\circ\text{C}$
Output Photologic[®] Sensor						
V_{CC}	Operating D.C. Supply Voltage	4.5		16.0	V	
I_{CCL}	Low Level Supply Current: Buffered with 10 k pull-up Buffered Open-Collector Output			7.5	mA	$V_{CC} = 16\text{ V}$, $I_F = 0\text{ mA}$ ⁽⁵⁾
	Inverted with 10 k pull-up Inverted Open-Collector Output			7.5	mA	$V_{CC} = 16\text{ V}$, $I_F = 4\text{ mA}$
I_{CCH}	High Level Supply Current: Buffered with 10 k pull-up Buffered Open-Collector Output			7.5	mA	$V_{CC} = 16\text{ V}$, $I_F = 4\text{ mA}$
	Inverted with 10 k pull-up Inverted Open-Collector Output			7.5	mA	$V_{CC} = 16\text{ V}$, $I_F = 0\text{ mA}$ ⁽⁵⁾
V_{OL}	Low Level Output Voltage: Buffered with 10 k pull-up Buffered Open-Collector Output			0.4	V	$V_{CC} = 4.5\text{ V}$, $I_{OL} = 16\text{ mA}$ $I_F = 0\text{ mA}$ ⁽⁵⁾
	Inverted with 10 k pull-up Inverted Open-Collector Output			0.4	V	$V_{CC} = 4.5\text{ V}$, $I_{OL} = 16\text{ mA}$ $I_F = 4\text{ mA}$
V_{OH}	High Level Output Voltage: Buffered with 10 k pull-up	$V_{CC}-1.5$			V	$V_{CC} = 4.5\text{ V}$ to 16 V , $I_{OH} = -800\text{ }\mu\text{A}$ $I_F = 4\text{ mA}$
	Inverted with 10 k pull-up	$V_{CC}-1.5$			V	$V_{CC} = 4.5\text{ V}$ to 16 V , $I_{OH} = -800\text{ }\mu\text{A}$ $I_F = 0\text{ mA}$ ⁽⁵⁾
I_{OH}	High Level Output Current: Buffered Open-Collector Output			10	μA	$V_{CC} = 16\text{ V}$, $V_{OH} = 30\text{ V}$, $I_F = 4\text{ mA}$, $T_A = 25^\circ\text{C}$
	Inverted Open-Collector Output			10	μA	$V_{CC} = 16\text{ V}$, $V_{OH} = 30\text{ V}$, $I_F = 0\text{ mA}$, $T_A = 25^\circ\text{C}$
$I_F(+)$	LED Positive-Going Threshold Current			4	mA	$V_{CC} = 5\text{ V}$, $T_A = 25^\circ\text{C}$
$I_F(+)/I_F(-)$	Hysteresis		1.2			$V_{CC} = 5\text{ V}$
t_r, t_f	Output Rise Time, Output Fall Time		50		ns	$V_{CC} = 5\text{ V}$, $T_A = 25^\circ\text{C}$ $I_F = 0$ or 4 mA
t_{PLH}, t_{PHL}	Propagation Delay Low-High & High-Low		3.0		μs	$R_L = 300\text{ }\Omega$ to 5 V $C_L = 50\text{ pF}$

Types OPB480, OPB490 "51" Series

Electrical Characteristics ($T_A = -40^\circ\text{C}$ to $+80^\circ\text{C}$ unless otherwise noted)

SYMBOL	PARAMETER	MIN	TYP	MAX	UNITS	TEST CONDITIONS
Input Diode						
V_F	Forward Voltage			1.7	V	$I_F = 20\text{ mA}$, $T_A = 25^\circ\text{C}$
I_R	Reverse Current			100	μA	$V_R = 2\text{ V}$, $T_A = 25^\circ\text{C}$
Output Photologic[®] Sensor						
V_{CC}	Operating D.C. Supply Voltage	4.5		16.0	V	
I_{CCL}	Low Level Supply Current: Buffered with 10 k pull-up Buffered Open-Collector Output			7.5	mA	$V_{CC} = 16\text{ V}$, $I_F = 0\text{ mA}^{(5)}$
	Inverted with 10 k pull-up Inverted Open-Collector Output			7.5	mA	$V_{CC} = 16\text{ V}$, $I_F = 8\text{ mA}$
I_{CCH}	High Level Supply Current: Buffered with 10 k pull-up Buffered Open-Collector Output			7.5	mA	$V_{CC} = 16\text{ V}$, $I_F = 8\text{ mA}$
	Inverted with 10 k pull-up Inverted Open-Collector Output			7.5	mA	$V_{CC} = 16\text{ V}$, $I_F = 0\text{ mA}^{(5)}$
V_{OL}	Low Level Output Voltage: Buffered with 10 k pull-up Buffered Open-Collector Output			0.4	V	$V_{CC} = 4.5\text{ V}$, $I_{OL} = 16\text{ mA}$ $I_F = 0\text{ mA}^{(5)}$
	Inverted with 10 k pull-up Inverted Open-Collector Output			0.4	V	$V_{CC} = 4.5\text{ V}$, $I_{OL} = 16\text{ mA}$ $I_F = 8\text{ mA}$
V_{OH}	High Level Output Voltage: Buffered with 10 k pull-up	$V_{CC}-1.5$			V	$V_{CC} = 4.5\text{ V to }16\text{ V}$, $I_{OH} = -800\text{ }\mu\text{A}$ $I_F = 8\text{ mA}$
	Inverted with 10 k pull-up	$V_{CC}-1.5$			V	$V_{CC} = 4.5\text{ V to }16\text{ V}$, $I_{OH} = -800\text{ }\mu\text{A}$ $I_F = 0\text{ mA}^{(5)}$
I_{OH}	High Level Output Current: Buffered Open-Collector Output			10	μA	$V_{CC} = 16\text{ V}$, $V_{OH} = 30\text{ V}$, $I_F = 8\text{ mA}$, $T_A = 25^\circ\text{C}$
	Inverted Open-Collector Output			10	μA	$V_{CC} = 16\text{ V}$, $V_{OH} = 30\text{ V}$, $I_F = 0\text{ mA}$, $T_A = 25^\circ\text{C}$
$I_{F(+)}$	LED Positive-Going Threshold Current			8	mA	$V_{CC} = 5\text{ V}$, $T_A = 25^\circ\text{C}$
$I_{F(+)} / I_{F(-)}$	Hysteresis		1.2			$V_{CC} = 5\text{ V}$
t_r, t_f	Output Rise Time, Output Fall Time		50		ns	$V_{CC} = 5\text{ V}$, $T_A = 25^\circ\text{C}$ $I_F = 0$ or 8 mA
t_{PLH}, t_{PHL}	Propagation Delay Low-High & High-Low		3.0		μs	$R_L = 300\text{ }\Omega$ to 5 V $C_L = 50\text{ pF}$

SLOTTED OPTICAL SWITCHES

Types OPB480, OPB490 "11" Series



Electrical Characteristics ($T_A = -40^\circ\text{C}$ to $+80^\circ\text{C}$ unless otherwise noted)

SYMBOL	PARAMETER	MIN	TYP	MAX	UNITS	TEST CONDITIONS
Input Diode						
V_F	Forward Voltage			1.7	V	$I_F = 20\text{ mA}$, $T_A = 25^\circ\text{C}$
I_R	Reverse Current			100	μA	$V_R = 2\text{ V}$, $T_A = 25^\circ\text{C}$
Output Photologic[®] Sensor						
V_{CC}	Operating D.C. Supply Voltage	4.5		16.0	V	
I_{CCL}	Low Level Supply Current: Buffered with 10 k pull-up Buffered Open-Collector Output			7.5	mA	$V_{CC} = 16\text{ V}$, $I_F = 0\text{ mA}^{(5)}$
	Inverted with 10 k pull-up Inverted Open-Collector Output			7.5	mA	$V_{CC} = 16\text{ V}$, $I_F = 12\text{ mA}$
I_{CCH}	High Level Supply Current: Buffered with 10 k pull-up Buffered Open-Collector Output			7.5	mA	$V_{CC} = 16\text{ V}$, $I_F = 12\text{ mA}$
	Inverted with 10 k pull-up Inverted Open-Collector Output			7.5	mA	$V_{CC} = 16\text{ V}$, $I_F = 0\text{ mA}^{(5)}$
V_{OL}	Low Level Output Voltage: Buffered with 10 k pull-up Buffered Open-Collector Output			0.4	V	$V_{CC} = 4.5\text{ V}$, $I_{OL} = 16\text{ mA}$ $I_F = 0\text{ mA}^{(5)}$
	Inverted with 10 k pull-up Inverted Open-Collector Output			0.4	V	$V_{CC} = 4.5\text{ V}$, $I_{OL} = 16\text{ mA}$ $I_F = 12\text{ mA}$
V_{OH}	High Level Output Voltage: Buffered with 10 k pull-up	$V_{CC}-1.5$			V	$V_{CC} = 4.5\text{ V}$ to 16 V , $I_{OH} = -800\text{ }\mu\text{A}$ $I_F = 12\text{ mA}$
	Inverted with 10 k pull-up	$V_{CC}-1.5$			V	$V_{CC} = 4.5\text{ V}$ to 16 V , $I_{OH} = -800\text{ }\mu\text{A}$ $I_F = 0\text{ mA}^{(5)}$
I_{OH}	High Level Output Current: Buffered Open-Collector Output			10	μA	$V_{CC} = 16\text{ V}$, $V_{OH} = 30\text{ V}$, $I_F = 12\text{ mA}$, $T_A = 25^\circ\text{C}$
	Inverted Open-Collector Output			10	μA	$V_{CC} = 16\text{ V}$, $V_{OH} = 30\text{ V}$, $I_F = 0\text{ mA}$, $T_A = 25^\circ\text{C}$
$I_F(+)$	LED Positive-Going Threshold Current			12	mA	$V_{CC} = 5\text{ V}$, $T_A = 25^\circ\text{C}$
$I_F(+)/I_F(-)$	Hysteresis		1.2			$V_{CC} = 5\text{ V}$
t_r, t_f	Output Rise Time, Output Fall Time		50		ns	$V_{CC} = 5\text{ V}$, $T_A = 25^\circ\text{C}$ $I_F = 0$ or 12 mA
t_{PLH}, t_{PHL}	Propagation Delay Low-High & High-Low		3.0		μs	$R_L = 300\text{ }\Omega$ to 5 V $C_L = 50\text{ pF}$

Types OPB480, OPB490 Series

PART NUMBER GUIDE

OPB 4 X X X X X

Optek Assembly

Photologic®
Photo Integrated Circuit
Sensor Family

Discrete Shell Material
Designation

8 - Base Mount IR Transmissive
Plastic Discrete Shell
With Wire Termination

9 - Base Mount Opaque
Plastic Discrete Shell
With Wire Termination

Aperture Width In Front
of Sensor
5 = 0.050" 1 = 0.010"

Aperture Width In Front
of Emitter
5 = 0.050" 1 = 0.010"

Mounting Configurations

T - Both Mounting Tabs
N - No Mounting Tabs
L - Single Mounting Tab
Emitter Side
P - Single Mounting Tab
Photologic® Side

Electrical Specification Variations

- 0 - Buffered with 10 k pull-up
- 1 - Buffered Open-Collector Output
- 2 - Inverted with 10 k pull-up
- 3 - Inverted Open-Collector Output

Schematic

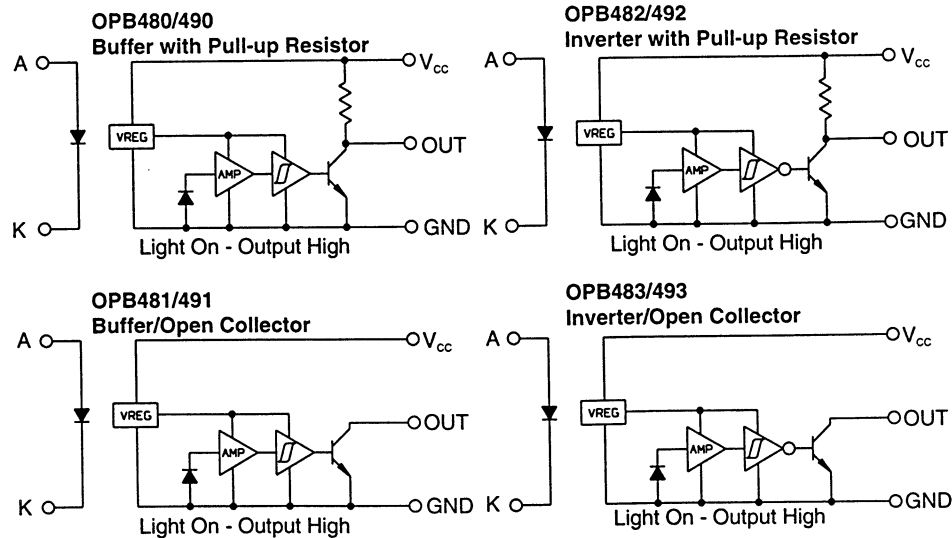

Photologic® Slotted Optical Switch

OPB460, OPB470, OPB480, OPB490 Series



Features:

- Choice of pins or wires mounting configuration
- Choice of aperture
- Choice of output configuration
- Choice of opaque or IR transmissive shell material
- Data rates to 250 kBaud
- Low power consumption

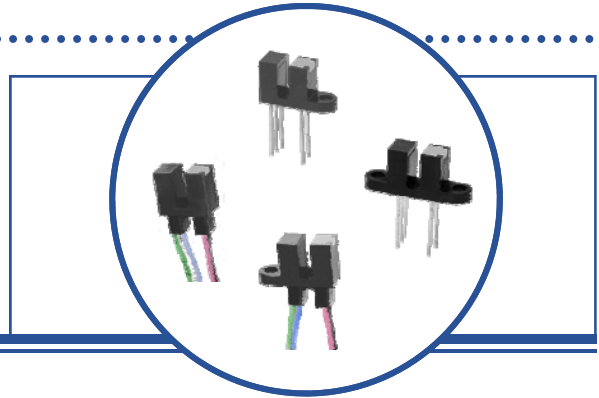

Description:

The **OPB460, OPB470, OPB480** and **OPB490** series of Photologic® photo integrated circuit switches provide optimum flexibility for the design engineer. Building from a standard housing with a 0.125" (3.180 mm) wide slot, a user can specify the type and polarity of TTL output, discrete shell material, aperture width and choice of mounting configurations. **OPB460** through **OPB473** have 0.425" (10.795 mm) PCBoard leads with 0.320" (8.1 mm) spacing. **OPB480** through **OPB493** have 24" (609 mm) 26 AWG wires (UL approved wires).

All devices in this series exhibit performance over supply voltages ranging from 4.5 V to 16.0 V, and may be specified as buffered or inverted with 10 kW Pull-up or Open Collector output. Devices are also TTI/LSTTL compatible and can drive up to 10 TTL loads.

Custom electrical, wire and cabling and connectors are available. Contact your local representative or OPTEK for more information.

Applications:

- Mechanical switch replacement
- Speed indication (tachometer)
- Mechanical limit indication
- Edge sensing

Part Number Guide — OPB460, OPB470, OPB480, OPB490 Series

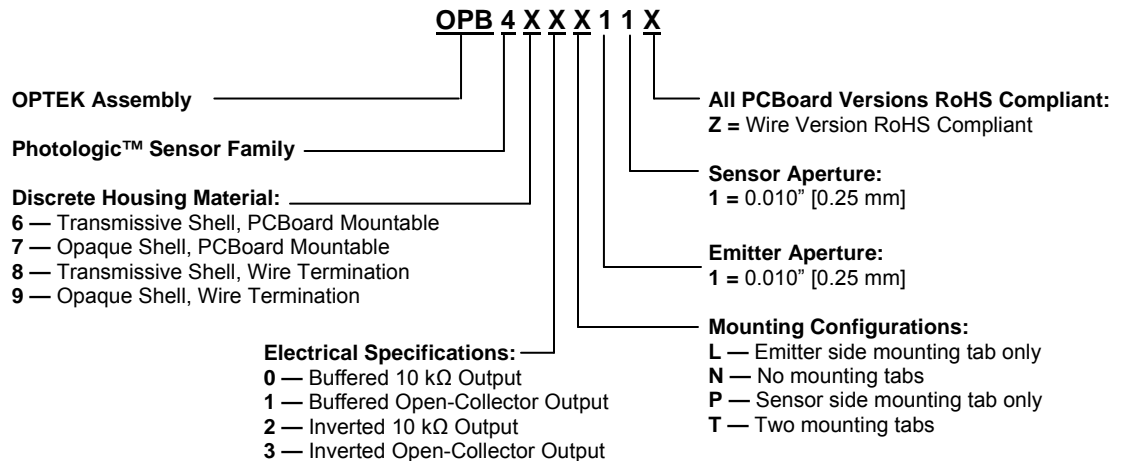

RoHS

OPTEK reserves the right to make changes at any time in order to improve design and to supply the best product possible.

Photologic® Slotted Optical Switch OPB460, OPB470, OPB480, OPB490 Series

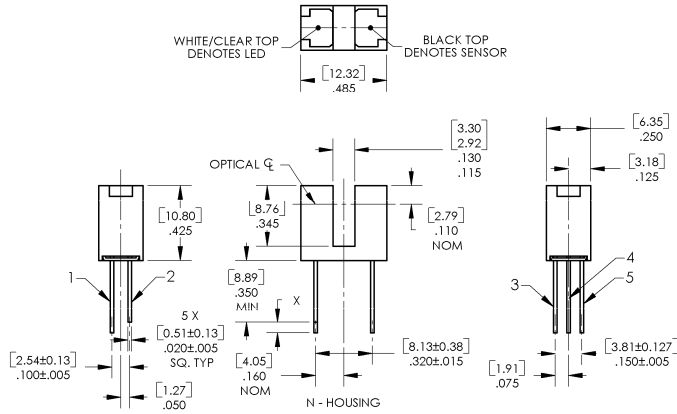

Color-Pin	Description
Red-1	Anode
Black-2	Cathode
White-3	Vcc
Blue-4	Output
Green-5	Ground

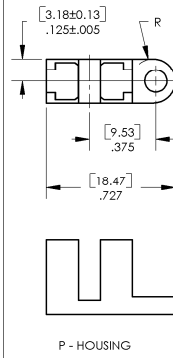
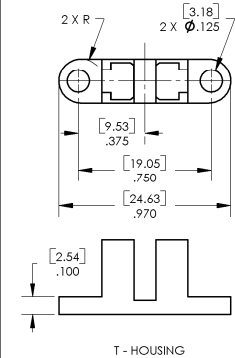
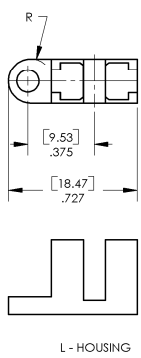

DIMENSIONS ARE IN: [MILLIMETERS]
INCHES

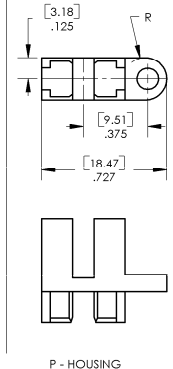
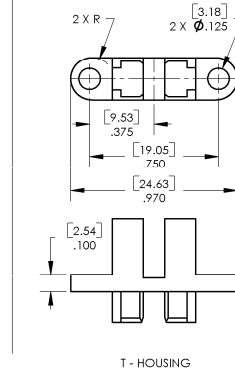
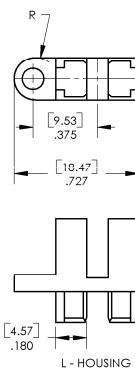
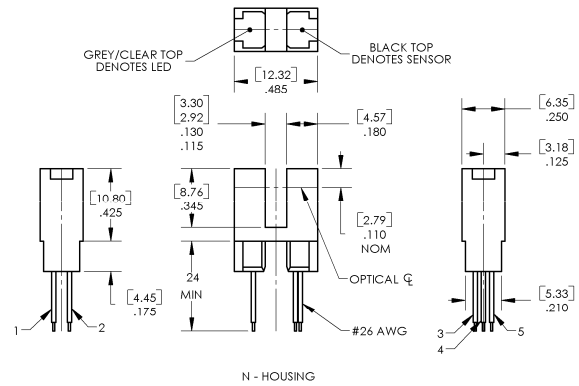

CONTAINS POLYSULFONE

To avoid stress cracking, we suggest using ND Industries' **Vibra-Tite** for thread-locking. **Vibra-Tite** evaporates fast without causing structural failure in OPTEK's molded plastics.

Applies to: OPB460, OPB470, OPB480, OPB490.

OPTEK reserves the right to make changes at any time in order to improve design and to supply the best product possible.

Absolute Maximum Ratings ($T_A=25^{\circ}\text{C}$ unless otherwise noted)

Storage & Operating Temperature Range	-40° C to +85° C
Lead Soldering Temperature [1/16 inch (1.6mm) from the case for 5 sec. with soldering iron] ⁽¹⁾	260°C

Input Infrared LED

Supply Voltage, V_{CC} (not to exceed 3 seconds)	18 V
Diode Forward DC Current	40 mA
Diode Reverse DC Voltage	2 V
Input Diode Power Dissipation ⁽²⁾	75 mW

Output Photologic®

Voltage at Output Lead (Open Collector Output)	25 V
Output Photologic® Power Dissipation ⁽³⁾	200 mW

Total Device Power Dissipation ⁽⁴⁾	275 mW
---	--------

Notes:

- (1) RMA flux is recommended. Duration can be extended to 10 seconds maximum when flow soldering.
- (2) Derate linearly 1.67 mW/°C above 25° C (OPB460, OPB470) or derate linearly 1.82 mW/°C above 25° C (OPB480, OPB490).
- (3) Derate linearly 1.50 mW/°C above 25° C (OPB460, OPB470) or derate linearly 1.64 mW/°C above 25° C (OPB480, OPB490).
- (4) Derate linearly 3.17 mW/°C above 25° C (OPB460, OPB470) or derate linearly 3.45 mW/°C above 25° C (OPB480, OPB490).
- (5) The OPB460/OPB470 series are terminated with 0.020" square leads designed for printed circuit board mounting.
- (6) The OPB480/OPB490 series of switches are terminated with 24" (609.600 mm) of 7-strand 26 AWG, UL rated insulated wire on each terminal. Insulation colors and functions are: red (anode), black (cathode), white (V_{CC}), blue (output) and green (ground). Other wire lengths and/or colors in addition to customer selected connectors are available. Contact your local representative or call the factory.

OPB460/470/480/490 Buffered 10K Pull-Up

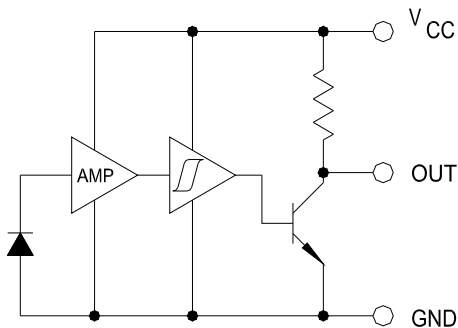

OPB461/471/481/491 Buffered Open-Collector

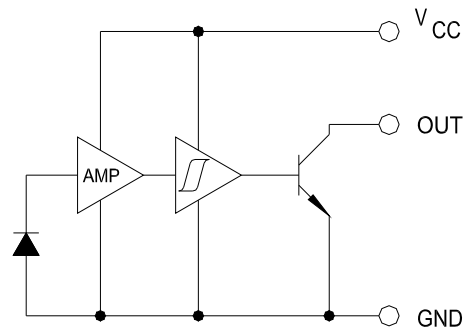

OPB462/472/482/492 Inverted 10K Pull-Up

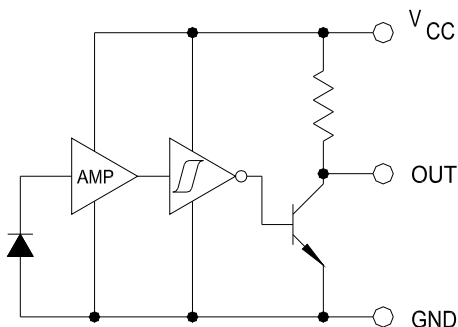

OPB463/473/483/493 Inverted Open-Collector

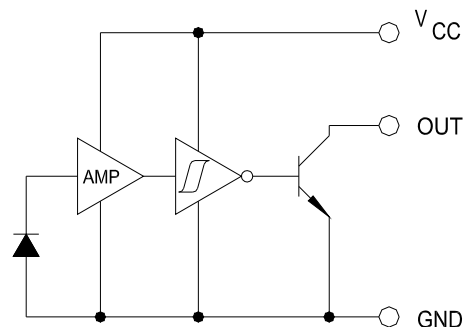

OPTEK reserves the right to make changes at any time in order to improve design and to supply the best product possible.

Electrical Characteristics ($T_A = 25^\circ\text{C}$ unless otherwise noted)

SYMBOL	PARAMETER	MIN	TYP	MAX	UNITS	TEST CONDITIONS
--------	-----------	-----	-----	-----	-------	-----------------

Input Diode

V_F	Forward Voltage	-	-	1.7	V	$I_F = 20\text{ mA}$, $T_A = 25^\circ\text{C}$
I_R	Reverse Current	-	-	100	μA	$V_R = 2\text{ V}$, $T_A = 25^\circ\text{C}$

Output Photologic® Sensor

V_{CC}	Operating DC Supply Voltage	4.5	-	16	V	
I_{CCL}	Low Level Supply Current: Buffered with 10k pull-up ⁽¹⁾ Buffered Open-Collector Output	-	-	7.5	mA	$V_{CC} = 16\text{ V}$, $I_F = 0\text{ mA}$ ⁽¹⁾
	Inverted with 10k pull-up: Inverted Open-Collector Output	-	-	7.5	mA	$V_{CC} = 16\text{ V}$, $I_F = 12\text{ mA}$
I_{CCH}	High Level Supply Current: Buffered with 10k pull-up Buffered Open-Collector Output	-	-	7.5	mA	$V_{CC} = 16\text{ V}$, $I_F = 12\text{ mA}$
	Inverted with 10k pull-up: Inverted Open-Collector Output	-	-	7.5	mA	$V_{CC} = 16\text{ V}$, $I_F = 0\text{ mA}$ ⁽¹⁾
V_{OL}	Low Level Output Voltage: Buffered with 10k pull-up Buffered Open-Collector Output	-	-	0.4	V	$V_{CC} = 4.5\text{ V}$, $I_{OL} = 16\text{ mA}$, $I_F = 0\text{ mA}$
	Inverted with 10k pull-up: Inverted Open-Collector Output	-	-	0.4	V	$V_{CC} = 4.5\text{ V}$, $I_F = 12\text{ mA}$ ⁽¹⁾
V_{OH}	High Level Output Voltage: Buffered with 10k pull-up	V_{CC} -1.5	-	-	V	$V_{CC} = 4.5\text{ V to }16\text{ V}$, No Load, $I_F = 12\text{ mA}$
	Inverted with 10k pull-up: Inverted Open-Collector Output ⁽¹⁾	V_{CC} -1.5	-	-	V	$V_{CC} = 4.5\text{ V to }16\text{ V}$, No Load, $I_F = 0\text{ mA}$
I_{OH}	High Level Output Current: Buffered Open-Collector Output	-	-	14	μA	$V_{CC} = 16\text{ V}$, $I_F = 12\text{ mA}$, $V_{OH} = 25\text{ V}$, $T_A = 25^\circ\text{C}$
	Inverted with 10k pull-up: Inverted Open-Collector Output ⁽¹⁾	-	-	14	μA	$V_{CC} = 16\text{ V}$, $I_F = 0\text{ mA}$, $V_{OH} = 25\text{ V}$, $T_A = 25^\circ\text{C}$
$I_{F(+)}$	LED Positive-Going Threshold Current	-	-	10	mA	$V_{CC} = 5\text{ V}$, $T_A = 25^\circ\text{C}$
$I_{F(+)} I_{F(-)}$	Hysteresis	-	1.4	-	-	$V_{CC} = 5\text{ V}$
t_r, t_f	Rise Time, Fall Time	-	50	-	ns	$V_{CC} = 5\text{ V}$, $T_A = 25^\circ\text{C}$, $I_F = 0$ or 12 mA
t_{PLH}, t_{PHL}	Propagation Delay	-	3	-	μs	$R_L = 300\ \Omega$ to 5 V , $C_L = 50\text{ pF}$

Notes:

- (1) Normal application would be with light source blocked, simulated by $I_F = 0\text{ mA}$.
- (2) All parameters tested using pulse technique.

OPTEK reserves the right to make changes at any time in order to improve design and to supply the best product possible.

OPB480T55 - Flag Next to Emitter

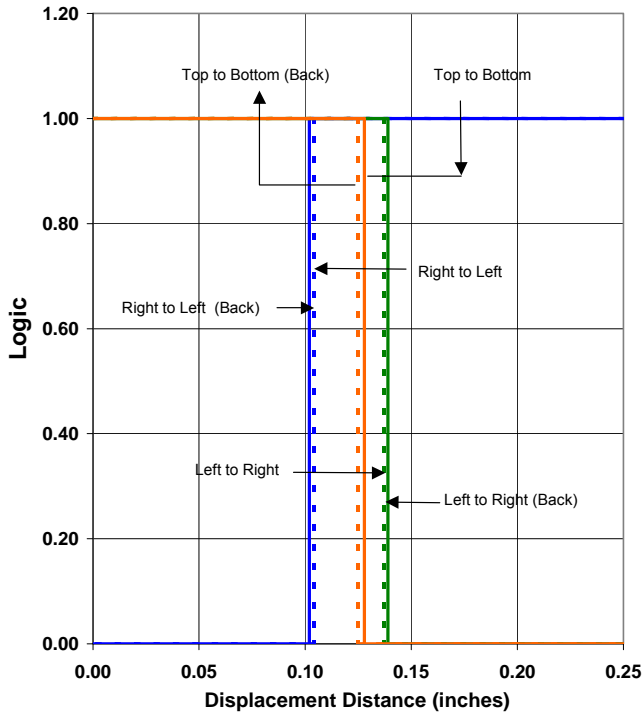

OPB480T55 - Flag Next to Sensor

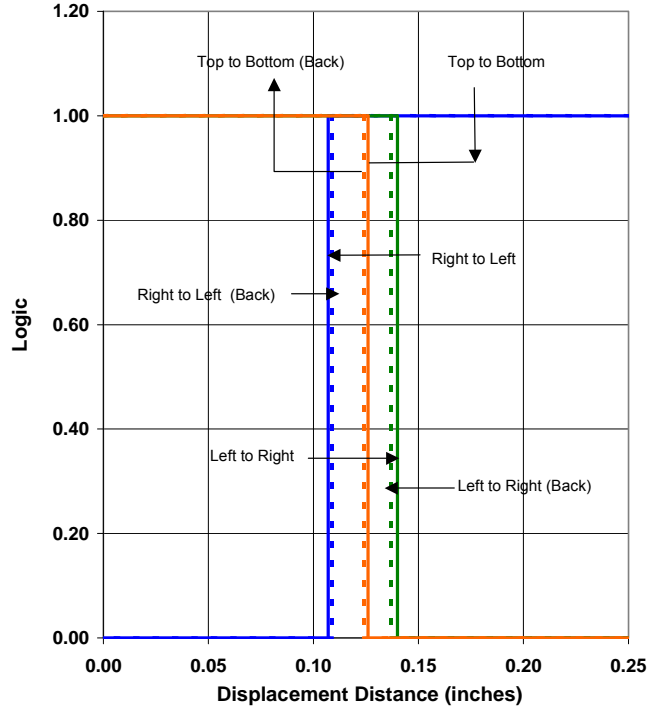

OPB480T55 - Flag in Middle of Slot

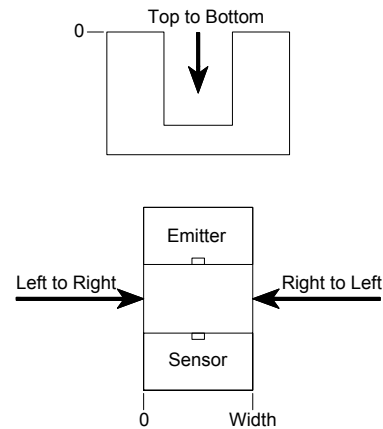
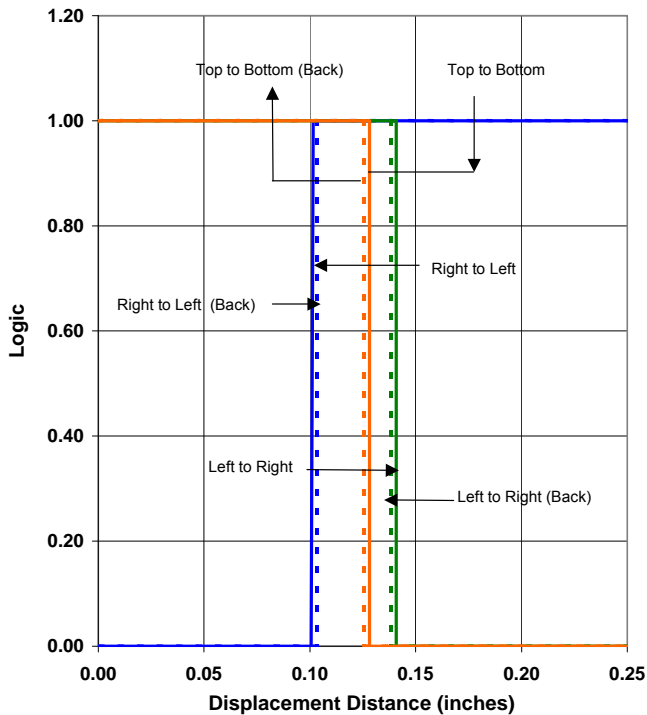

OPTEK reserves the right to make changes at any time in order to improve design and to supply the best product possible.

OPB481N51 - Flag Next to Emitter

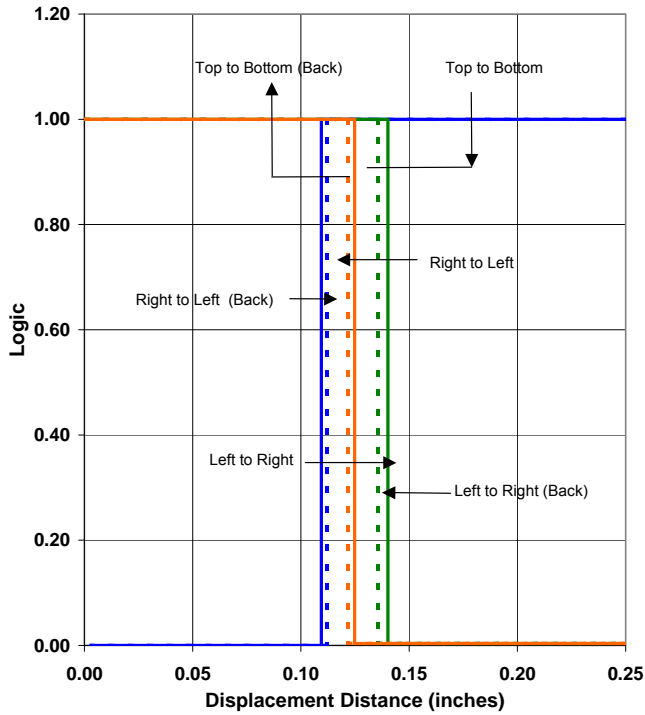

OPB481N51 - Flag Next to Sensor

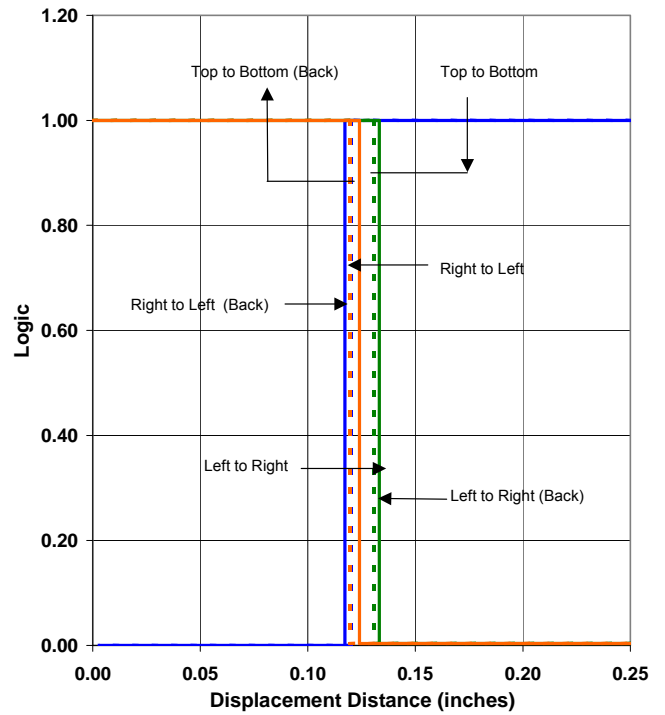

OPB481N51 - Flag in Middle of Slot

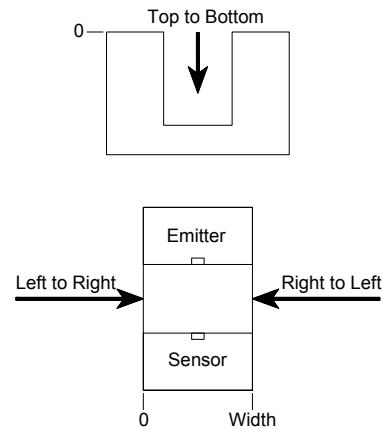
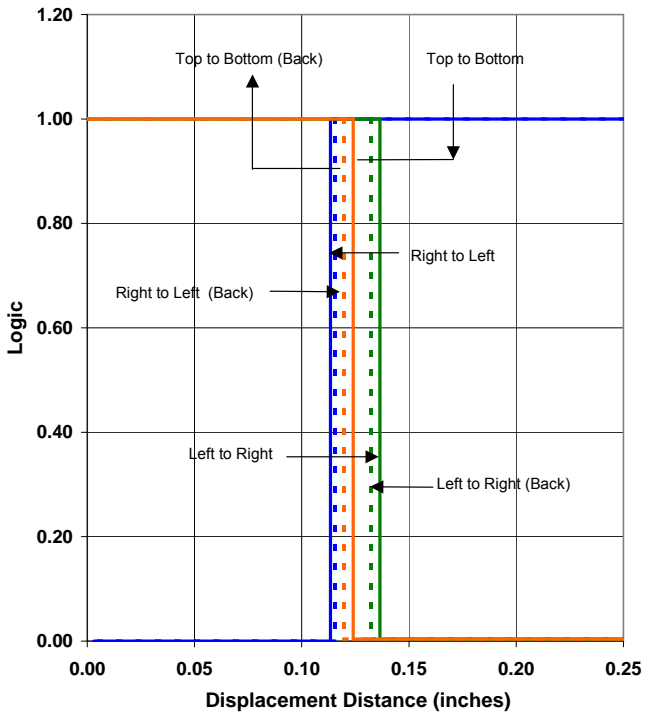

OPTEK reserves the right to make changes at any time in order to improve design and to supply the best product possible.

OPB460N11 - Flag Next to Emitter

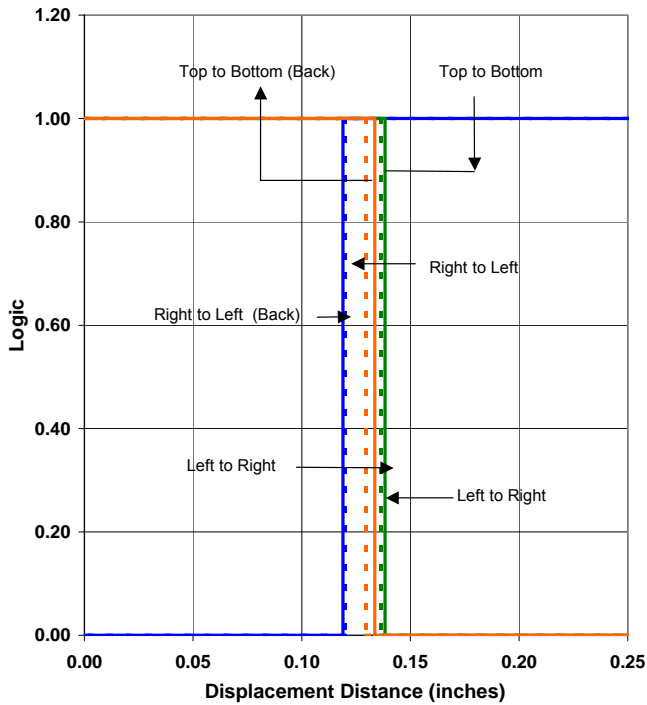

OPB460N11 - Flag Next to Sensor

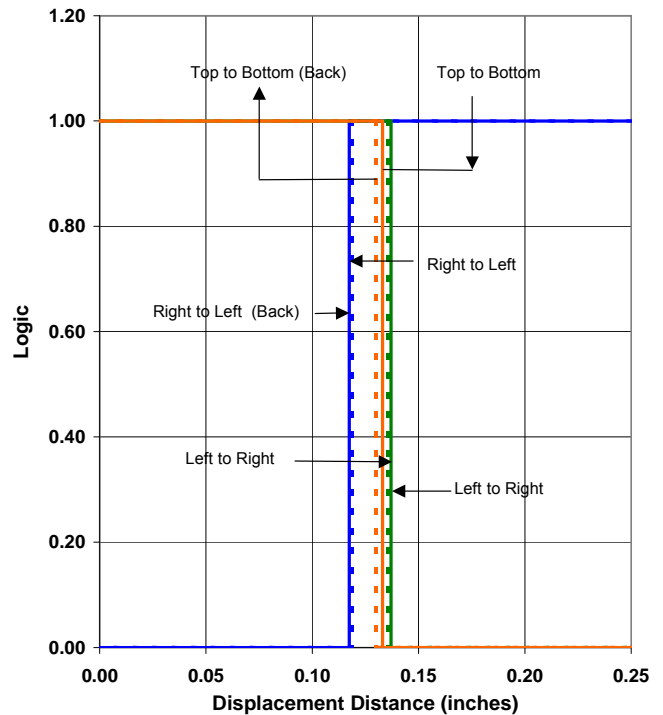

OPB460N11 - Flag in Middle of Slot

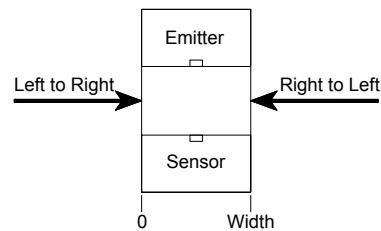
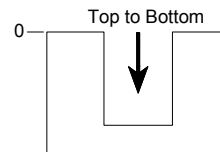
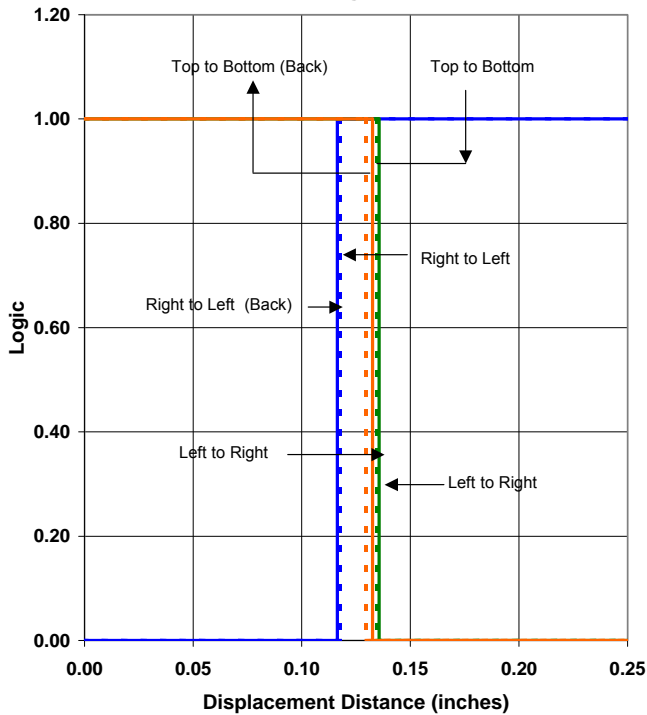

OPTEK reserves the right to make changes at any time in order to improve design and to supply the best product possible.