



DESCRIPTION

The IF-E92A and IF-E92B are blue LEDs housed in a “connector-less” style plastic fiber optic package. The IF-E92A contains a Silicon Carbide die with a spectral output peaking at 430 nm and the IF-E92B die is made from Gallium Nitride peaking at 470 nm. The device package features an internal micro-lens and a precision-molded PBT housing to ensure efficient optical coupling with standard 1000 μm core plastic fiber cable.

APPLICATION HIGHLIGHTS

These LEDs are low-cost alternatives to other light sources for producing a narrowband blue light output that can be efficiently coupled into a fiber cable. They can be used in a variety of sensor and display applications that require a narrowband optical light source whose intensity can be easily adjusted or modulated without changing optical spectrum. When combined with red and green LEDs the IF-E92A and IF-E92B provide an RGB source for generating white or multicolored light. Applications include process control for color identification/separation and demonstration of wavelength division multiplexing for educational purposes. The IF-E92A and IF-E92B are also capable of digital data rates of 1 Mbps and 800 kbps respectively. The electrical drive circuit design is the same as that of other LEDs, making the IF-E92A and IF-E92B cost-effective light sources in a variety of analog, digital sensor and lighting applications.

APPLICATIONS

- ▶ Optical Sensors
- ▶ RGB Light Sources
- ▶ Color Separation for Process Control
- ▶ Medical Instruments
- ▶ Analog and Digital Data Links
- ▶ Robotics Communications
- ▶ Display Indicators
- ▶ Electronic Games
- ▶ Wavelength Multiplexing
- ▶ Fluorescent Instruments

FEATURES

- ◆ Easily Adjusted or Modulated Blue Optical Output
- ◆ Fast Transition Times
- ◆ No Optical Design Required
- ◆ Mates With Standard 1000 μm Core Jacketed Plastic Fiber Cable
- ◆ Internal Micro-Lens for Efficient Optical Coupling
- ◆ Inexpensive Plastic Connector Housing
- ◆ Connector-Less Fiber Termination

MAXIMUM RATINGS

($T_A = 25^\circ\text{C}$)

Operating and Storage Temperature Range (T_{OP}, T_{STG})	-40° to 60°C
Junction Temperature (T_J)	85°C
Soldering Temperature (2 mm from case bottom) (T_S) $t \leq 5$ s	240°C
Reverse Voltage (V_R)	5 V
Power Dissipation (P_{TOT}) $T_A = 25^\circ\text{C}$	60 mW
De-rate Above 25°C	1.1 mW/°C
Forward Current, DC (I_F)	35 mA
Surge Current (I_{FSM}) $t \leq 10 \mu\text{s}$	75 mA

CHARACTERISTICS ($T_A = 25^\circ\text{C}$)

Parameter	Symbol	IF-E92A	IF-E92B	Unit
Peak Wavelength	λ_{PEAK}	430	470	nm
Spectral Bandwidth (50% of I_{MAX})	$\Delta\lambda$	65	25	nm
Output Power Coupled into Plastic Fiber (1 mm core diameter). Distance Lens to Fiber ≤ 0.1 mm, 10 cm polished fiber, $I_F = 10$ mA	Φ_{min}	25 -16	75 -11	μW dBm
Switching Times (10% to 90% and 90% to 10%) ($R_L = 47 \Omega$, $I_F = 10$ mA)	t_r, t_f	.5	.6	μs
Capacitance ($V_F = 0$, $F = 1$ MHz)	C_0	100	100	pF
Forward Voltage ($I_F = 20$ mA)	V_f	4.5 max	4.0 max	V
Temperature Coefficient, λ_{PEAK}	TC_λ	.16	.16	nm/K

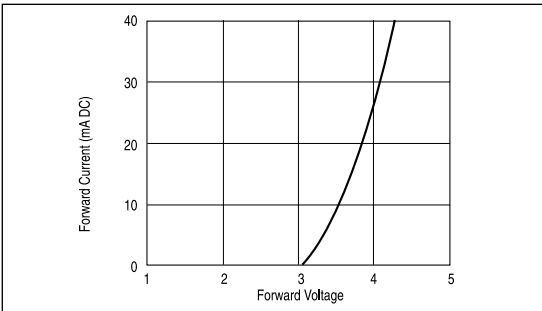

FIGURE 1. Forward current versus forward voltage.

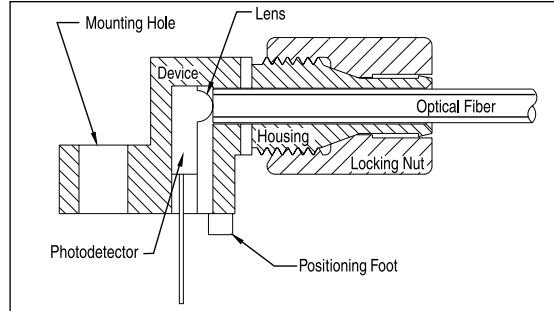

FIGURE 3. Cross-section of fiber optic device.

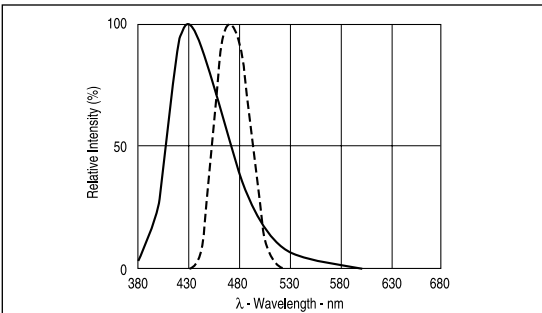

FIGURE 2. Typical spectral output vs. wavelength.

FIBER TERMINATION INSTRUCTIONS

1. Cut off the ends of the optical fiber with a single-edge razor blade or sharp knife. Try to obtain a precise 90-degree angle (square).
2. Insert the fiber through the locking nut and into the connector until the core tip seats against the internal micro-lens.
3. Screw the connector locking nut down to a snug fit, locking the fiber in place.

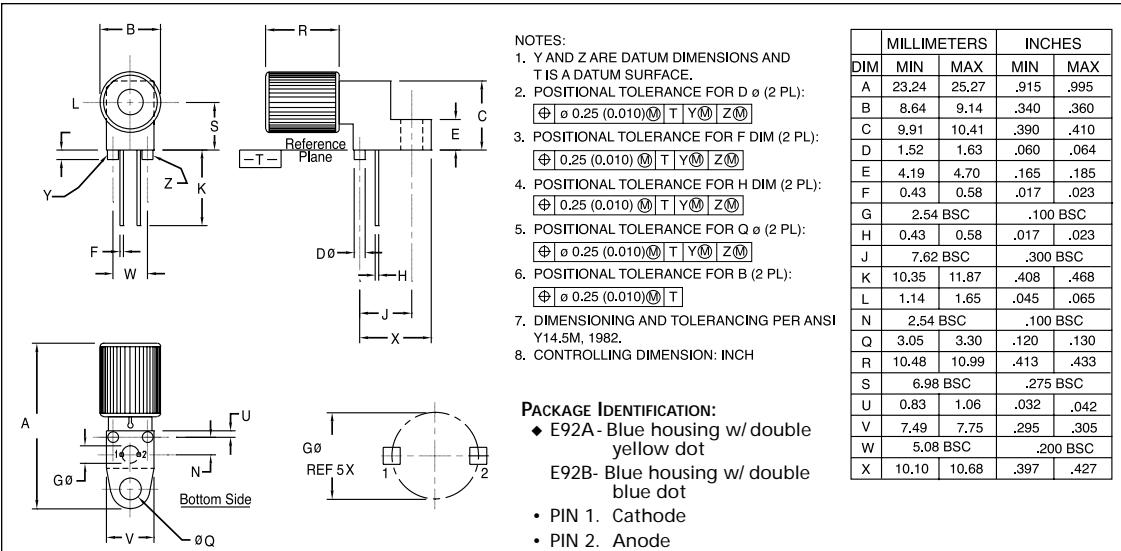

FIGURE 4. Case outline.