



Extend your USB

USB•400FO

Extends any High Speed USB 2.0 device up to 1640 feet (500 meters) from the computer with built-in 4 port hub over multimode fiber optics cable.

The USB•400FO extends any USB device up to 1,650 feet from the location of your computer, eliminating the 17.5 feet distance limitation of USB. The USB•400FO also includes a remote 4 port USB HUB to operate up to four USB devices remotely using "Extreme USB" technology.

How It Works

The USB•400FO sender unit is connected to the computer using the supplied USB cable. The extended peripheral(s) are connected to the receiver unit. Two multimode LC fiber optic cables are used to link the the sender to the receiver with HUB.

Features:

- Extreme USB technology extends the range of USB 2.0 devices up to 1650 meters (500 meters) using fiber-optic cable
- Remote extender 400FOR is equipped with 4 USB ports
- Provides support for both low-speed and high-speed USB devices
- Comes with a USB cable, power adapters and user guide
- Fully compliant with USB 2.0 specification as certified by the USB Implementer's Forum
- Number of devices can be expanded using standard USB hubs

Specifications:

- USB device support: 480Mbps
- USB Input Connectors: type B
- USB Output Connectors: type A
- Link Connector: LC
- Power Supply: 15V DC
- Dimensions: 4.75" W x 1.75" H x 5" D
- Shipping Weight: 5 lbs.

Package Includes:

- USB•400FOS Send Unit
- USB•400FOR Receive Unit
- One 6ft A to B USB cable
- Two 5V Power Supply



EXT-USB-400FO



USB•400 FO
USER MANUAL

ASKING FOR ASSISTANCE

Technical Support:

Telephone (818) 772-9100
(800) 545-6900

Fax (818) 772-9120

Technical Support Hours:

8:00 AM to 5:00 PM Monday thru Friday.

Write To:

Gefen Inc.
c/o Customer Service
20600 Nordhoff St.
Chatsworth, CA 91311

support@gefen.com
www.gefen.com

Notice

Gefen Inc. reserves the right to make changes in the hardware, packaging and any accompanying documentation without prior written notice.

The USB 400 FO is a trademark of Gefen Inc.

TABLE OF CONTENTS

- 1** Introduction / Operation Notes
- 2** Features
- 3** How It Works
- 4** USB 400 FO Panel Layout
- 5** USB 400 FO Series Installation / Check list
- 6** Wiring Diagram
- 7** Troubleshooting Hints
- 8** Troubleshooting Hints
- 9** System Specifications
- 10** Warranty

INTRODUCTION

Thank you for purchasing the ex•tend•it USB•400 Series. Incorporating *ExtremeUSB*, the new USB•400 model allows users the benefits of USB technology beyond the desktop, extending your computer keyboard, mouse, trackball, and any USB device up to 1650 feet away from the location of your Macintosh or PC computer.

The USB•400 system consists of two units: the USB•400S Sender resides next to the host computer, and the USB•400R Receiver resides next to the extended USB type device connected by conventional USB cables.

The USB•400 signal controls the keyboard, mouse, trackball and other USB devices by buffering the keyboard/mouse signal through send and receive line drivers, and the signal is extended by using standard fiber optic cabling.

The USB•400FO extends any USB device up to 1,650 feet from the location of your computer, eliminating the 17.5 feet distance limitation of USB. The USB•400FO also includes a remote 4 port USB HUB to operate up to four USB devices remotely using “Extreme USB” technology.

OPERATION NOTES

READ THESE NOTES BEFORE INSTALLING OR OPERATING THE DVI•3000HD SYSTEM

- The USB 400 FO units are housed in a metal box for better RF shielding.
- The USB 400 FO uses two multi-mode LC fiber optic cables fiber optics to connect the sender and receiver.
- The USB•400 units were designed to operate on USB type computers. **DO NOT** attempt to use this equipment with any other type computers.
- Use the computer's USB port when using a local keyboard that is not extended with the USB•400 sender unit.
- In order to operate properly, the USB•400S and USB•400R units must be connected, powered up, and the LC fiber optic cable installed between both units.
- The length of cable used to connect the USB•400S send unit to the USB•400R receiver unit **MUST NOT EXCEED** 1650 feet.

FEATURES

Features

- Extreme USB technology extends the range of USB 2.0 devices up to 1650 meters (500 meters) using fiber-optic cable
- Remote extender 400FOR is equipped with 4 USB ports
- Provides support for both low-speed and high-speed USB devices
- Comes with a USB cable, power adapters and user guide
- Fully compliant with USB 2.0 specification as certified by the USB Implementers Forum
- Number of devices can be expanded using standard USB hubs



HOW IT WORKS

CONTENTS

The USB 400 FO system consists of:

- (1) USB•400FOS Send Unit
- (1) USB•400FOR Receive Unit
- (1) 6ft A to B USB cable
- (2) 5V Power Supply

HOW IT WORKS

The USB•400FO sender unit is connected to the computer using the supplied USB cable. The extended peripheral(s) are connected to the receiver unit. Two multi mode LC fiber optic cables are used to link the sender to the receiver with HUB.

USB 400 FO PANEL LAYOUT



5V Power Supply
USB Inputs for devices

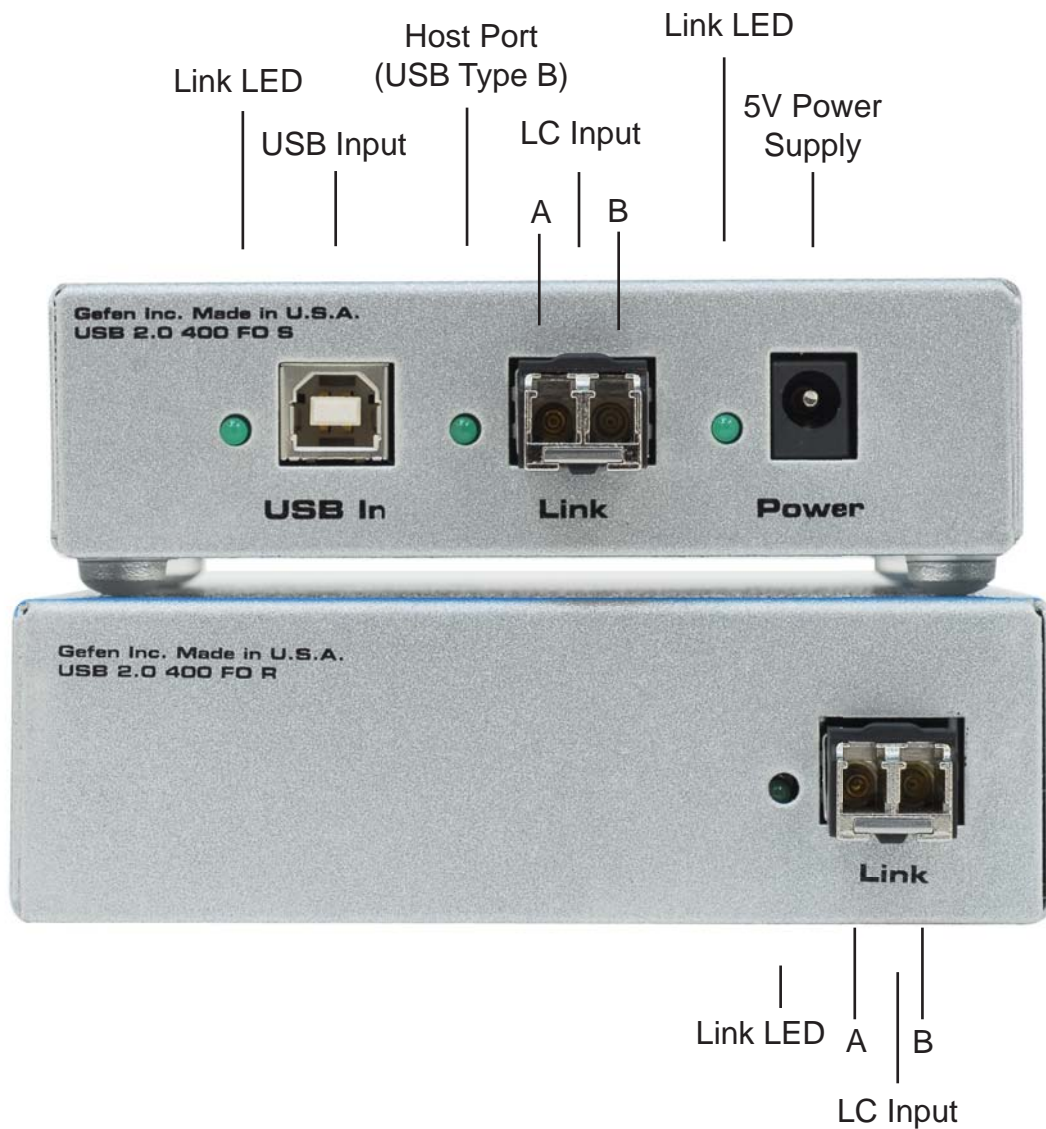

USB 400 FO SERIES INSTALLATION

USB•400R (Receiver Unit)

1. Place the USB•400R unit close to the USB device to be served.
2. Connect the USB devices to the USB•400R unit.
3. Connect the power adapter to a suitable AC source wall outlet.
4. Connect the power adapter to the USB•400R unit using the supplied cable.

USB•400S (Sender Unit)

5. Place the USB•400S unit close to the host computer.
6. Connect the power adapter to the USB•400S unit using the supplied cable.
7. Connect the USB•400S unit to the USB•400R unit using the desired length of fiber optic cable outfitted with LC connectors with A, on the sender matching B on the receiver, and B on the sender matching A on the receiver.
8. Connect the USB•400S unit to the host computer using the 6ft. USB cable supplied with the unit .

CHECK LIST

1. On the USB•400S send unit, check that the power indicator is GREEN.
2. On the USB•400S send unit, check that the link indicator is GREEN.
3. On the USB•400R receiver unit, check that the power indicator is GREEN.
4. Once all LEDs are illuminated as required, the USB•400 is ready to accept a peripheral device at the USB port on the USB•400R receiver unit. Follow the installation instructions as if one were installing the device directly into a computer's USB port.
5. On the host computer, check that a general purpose hub is visible from the Control Panel/System applet. Once connected, a USB peripheral device causes its host computer to automatically enumerate it. This simply means that the computer must identify the new device, assign it an ID, and ensure that the required software drivers are available for loading when the device is to be used.
6. The USB•400 is not an end device. Consequently, it does not have a software component or driver to be loaded. Some peripheral devices that are to be attached to the USB•400 will have a USB Driver diskette or CD-ROM which will need to be inserted after initial connection to a USB port on the USB•400 model.

WIRING DIAGRAM

USB 400 FO

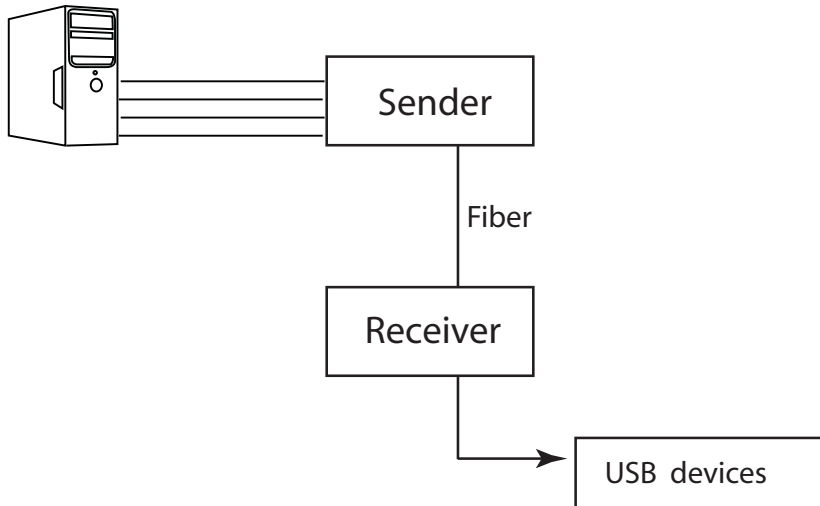

Extends any High Speed USB 2.0 device up to 1640 feet (500 meters) from the computer with built-in 4 port hub over multimode fiber optics cable.

TROUBLESHOOTING HINTS

Symptoms/Cause	Remedy
<p>All LEDs on Sender unit are off. Cause: The Sender unit is not receiving power from the adapter</p>	<ol style="list-style-type: none"> 1. Ensure that a power adapter is connected to the Sender unit. 2. Check that the adapter is connected to a live source of electrical power.
<p>All LEDs on Receiver unit are off. Cause: The Receiver unit is not receiving power from the adapter</p>	<ol style="list-style-type: none"> 1. Ensure that a power adapter is connected to the Receiver unit. 2. Check that the adapter is connected to a live source of electrical power.
<p>Link LEDs on Sender unit and Receiver unit are off. Cause: There is no connection between the Sender unit and the Receiver unit.</p>	<ol style="list-style-type: none"> 1. Ensure that a fiber-optic cable with crossover is connected between the Sender unit and the Receiver unit. 2. Connect a short fiber-optic crossover patch cord between the Sender unit and the Receiver unit. Recheck the operation of the system.
<p>Link LED on Sender unit is on; Host LED on Sender unit is off. Cause: a) The computer is not functioning. b) The Sender unit is not connected to the computer. c) The computer does not support USB hubs. d) The USB 2.0 Ranger is malfunctioning.</p>	<ol style="list-style-type: none"> 1. Disconnect all USB devices from the Receiver unit. 2. Disconnect the Sender unit from the computer. 3. Disconnect and then reconnect the power adapter to the USB 2.0 Ranger. 4. Reconnect the Sender unit to the computer. 5. In the Universal Serial Bus controllers section of Device Manager, check that the USB 2.0 Ranger is recognized as a "Generic USB Hub". 6. If the USB 2.0 Ranger is not recognised, contact technical support for assistance.

TROUBLESHOOTING HINTS

Symptoms/Cause	Remedy
<p>A device is connected to the Receiver unit and the corresponding Device LED is off</p> <p>Cause:</p> <ul style="list-style-type: none"> a) The USB device is malfunctioning. b) The computer does not recognise the USB device. c) The application software for the device is not operating. d) The USB 2.0 Ranger is malfunctioning. 	<ol style="list-style-type: none"> 1. Disconnect the USB 2.0 Ranger from the computer. 2. Connect the USB device directly to the USB port on the computer. 3. If the device does not operate properly, consult the user documentation for the device. 4. If the device operates properly when directly connected to the computer, connect another device (of a different type) to the USB 2.0 Ranger. Connect USB 2.0 Ranger to the computer. 5. If the second device does not operate, the USB 2.0 Ranger may be malfunctioning. Contact technical support for assistance. 6. If the second device does operate properly, the first device may not be compatible with the USB 2.0 Ranger. Contact technical support for assistance.
<p>All LEDs on both the Sender unit and Receiver unit are on but the device does not operate correctly</p> <p>Cause:</p> <ul style="list-style-type: none"> a) The USB device is malfunctioning. b) The computer does not recognise the USB device. c) The application software for the device is not operating. d) The USB 2.0 Ranger is malfunctioning. 	<ol style="list-style-type: none"> 1. Disconnect the USB 2.0 Ranger from the computer. 2. Connect the USB device directly to the USB port on the computer. 3. If the device does not operate properly, consult the user documentation for the device. 4. If the device operates properly when directly connected to the computer, connect another device (of a different type) to the USB 2.0 Ranger. Connect the USB 2.0 Ranger to the computer. 5. If the second device does not operate, the USB 2.0 Ranger may be malfunctioning. Contact technical support for assistance. 6. If the second device does operate properly, the first device may not be compatible with the USB 2.0 Ranger. Contact technical support for assistance.

SYSTEM SPECIFICATIONS

USB device support.....	480Mbps
USB Input Connectors.....	type B
USB Output Connectors.....	type A
Link Connector.....	LC
Power Supply.....	5V DC
Dimensions.....	4.75" W x 1.75" H x 5" D
Shipping Weight.....	5 lbs.

WARRANTY

Gefen Inc. warrants the equipment it manufactures to be free from defects in material and workmanship.

If equipment fails because of such defects and Gefen Inc. is notified within two (2) year from the date of shipment, Gefen Inc. will, at its option, repair or replace the equipment, provided that the equipment has not been subjected to mechanical, electrical, or other abuse or modifications.

Equipment that fails under conditions other than those covered will be repaired at the current price of parts and labor in effect at the time of repair. Such repairs are warranted for ninety (90) days from the day of reshipment to the Buyer.

This warranty is in lieu of all other warranties expressed or implied, including without limitation, any implied warranty or merchantability or fitness for any particular purpose, all of which are expressly disclaimed.

1. Proof of sale may be required in order to claim warranty.
2. Customers outside the US are responsible for shipping charges to and from Gefen.
3. Copper cables are limited to a 30 day warranty and cable must be free from any scratches, markings, and neatly coiled.

The information in this manual has been carefully checked and is believed to be accurate. However, Gefen Inc. assumes no responsibility for any inaccuracies that may be contained in this manual. In no event will Gefen Inc., be liable for direct, indirect, special, incidental, or consequential damages resulting from any defect or omission in this manual, even if advised of the possibility of such damages. The technical information contained herein regarding USB 400 FO features and specifications is subject to change without notice.