

1 - 3/4" (44.5mm) Inch Single Turn Wirewound Precision Potentiometer



FEATURES

- Servo, Screw or Bushing Mount
- 5Ω to 50KΩ

ELECTRICAL SPECIFICATIONS		
PARAMETER		
Total Resistance Tolerance: 50Ω and above Below 50Ω	STANDARD 5Ω to 50KΩ ± 3% ± 5%	SPECIAL 65KΩ ± 1% ± 3%
Absolute Minimum Resistance	Linearity x total resistance or 0.5Ω, whichever is greater	
End Voltage	Linearity x total applied voltage for total resistance above 20Ω, 2.0% of total applied voltage for 20Ω and below	
Linearity (Independent) 5Ω to 50Ω 50Ω to 500Ω 500Ω to 2KΩ 2KΩ and above	STANDARD ± 1.00% ± 0.50% ± 0.25% ± 0.25%	BEST PRACTICAL ± 0.50% ± 0.35% ± 0.20% ± 0.15%
Noise	100Ω ENR	
Rotation	350° ± 2°	
Power Rating: Section 1: 3.5 watts Additional Sections	70°C ambient derated to zero @ 125°C 75% of the rating of section 1 (2.6 watts at 70°C)	
Insulation Resistance	1000MΩ minimum, 500V _{DC}	
Dielectric Strength	1000V _{RMS} , 60Hz	
Taps (Extra)	STANDARD ± 1%	SPECIAL ± 19%
Phasing (CCW End Points)	Additional sections phased to section 1 within ± 1°	

ORDERING INFORMATION			
The Model 202 can be ordered from this data sheet with a variety of alternate characteristics, as shown above. For most rapid service on your order, please state:			
202	1	3	XXX
MODEL	MOUNTING	TOTAL RESISTANCE OF EACH SECTION	NUMBER OF SECTIONS IN GANG
	1. Bushing 2. Servo 3. Screw	Beginning with the section nearest the mounting end	
Example: Model 202, Screw, 15K/1500Ω/5Ω 3 sections Example: Model 202, Bushing, 10K, single section Example: 202 - 1 - 3 - XXX			
Other characteristics will be standard as described on this data sheet. If special characteristics are required, such as: special linearity tolerance, special resistance tolerance, extra taps, non-linear functions, etc., please state these on your order and allow additional lead time for delivery.			
NOTE: Specifications subject to change without notice			

Model 202

Spectrol

1 - 3/4" (44.5mm) Single Turn Wirewound Precision Potentiometer

DIMENSIONS in inches (millimeters)

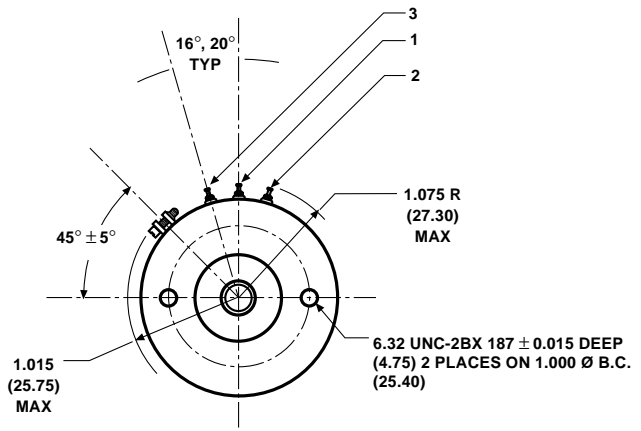
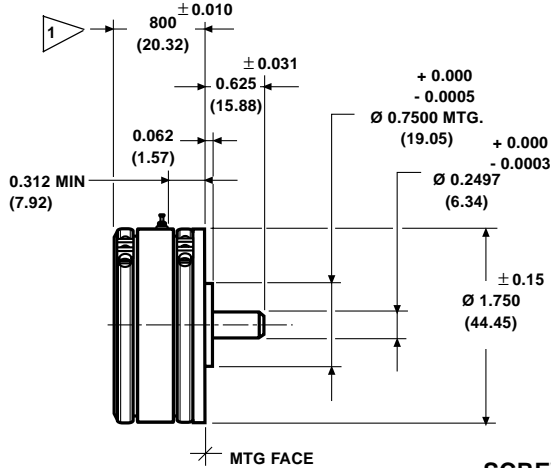

SCREW MOUNT

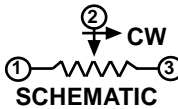
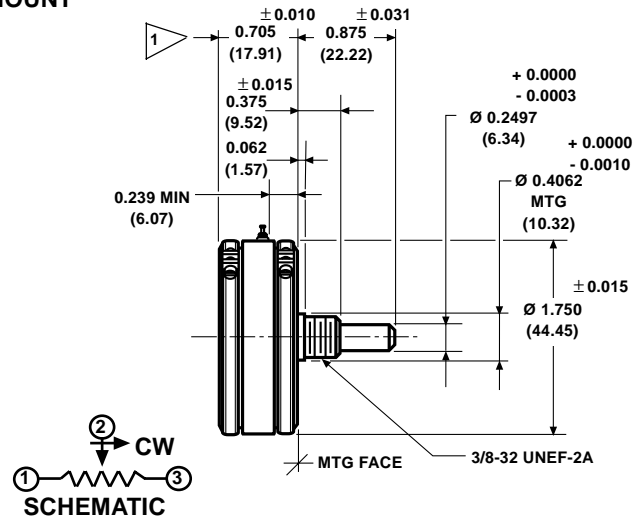
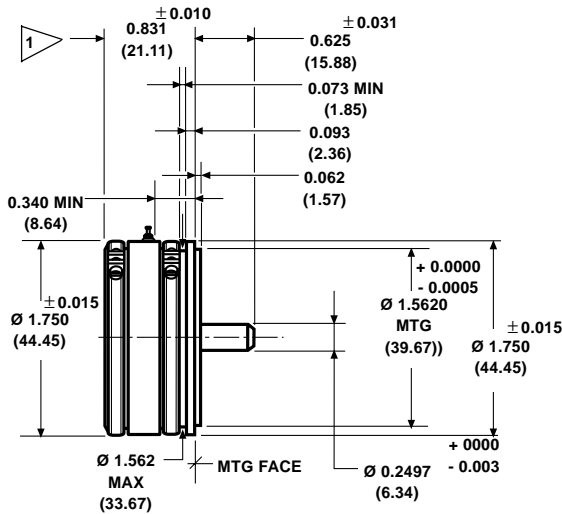

BUSHING MOUNT

SERVO MOUNT

TOLERANCES: UNLESS OTHERWISE NOTED
DECIMALS ± 0.005 ANGLES ± 2°

± 0.002
1 ADD 0.500 FOR EACH ADDITIONAL SECTION
(12.70)

MECHANICAL SPECIFICATIONS		
PARAMETER		
Mechanical Rotation	360° (continuous)	
Bearing Type	Servo Mount: Ball bearing Bushing Mount: Sleeve bearing	
Ganging	6 sections maximum, Terminal alignment, added sections, within ± 10° of section 1 Terminals	
Torque (Maximums)	STARTING	RUNNING
1 Section	0.7 oz - in (50.40gm - cm)	0.4 oz - in (28.80gm - cm)
Bushing, 1 Section	1.0 oz - in (72.00gm - cm)	0.7 oz - in (50.40gm - cm)
Each Additional Section	0.4 oz - in (28.80gm - cm)	0.3 oz - in (21.60gm - cm)
Mechanical Runouts (Maximums):	SERVO & SCREW	BUSHING
Shaft Runout (TIR/in)	0.002 in (0.05cm)	0.002 in (0.05cm)
Pilot Dia. Runout (TIR)	0.002 in (0.05cm)	0.002 in (0.05cm)
Lateral Runout (TIR)	0.003 in (0.08cm)	0.005 in (0.13cm)
Shaft End Play	0.005 in (0.13cm)	0.005 in (0.13cm)
Shaft Radial Play	0.002 in (0.05cm)	0.003 in (0.08cm)
Moment of Inertia	1.0gm - cm ² per section maximum	
Weight (Maximums):		
Single Section	3.0 oz (85.05 gm)	
Each Additional Section	1.0 oz (28.35 gm)	

1 - 3/4" (44.5mm) Single Turn Wirewound Precision Potentiometer

Spectrol

MATERIAL SPECIFICATIONS	
Housing and Lids	Aluminum, anodized
Shaft and Clamp Rings	Stainless steel, non-magnetic non-passivated
Terminals	Brass, plated for solderability
Bushing Mount Hardware	
Lockwasher Internal Tooth:	Steel, nickel plated
Panel nut:	Brass, nickel plated

MARKING	
Unit	Units shall be marked with Spectrol name, model number and data code, on each section, resistance and tolerance, linearity, and terminal identification

ENVIRONMENTAL SPECIFICATIONS	
Vibration	15g thru 2000 Hz
Shock	50g
Salt Spray	96 Hours
Rotational Life	1 million shaft revolutions
Load Life	900 Hours
Operating Temperature Range	- 55°C to + 125°C
Moisture Resistant	-

POWER RATING CHART
 (Ratings for cup No. 1.
 Additional cups 75% of values shown)

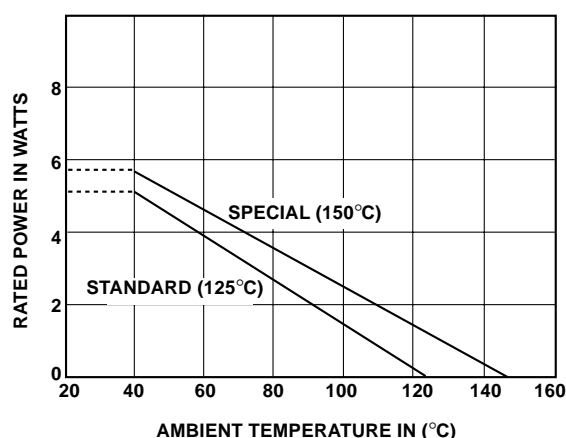

RESISTANCE ELEMENT DATA					
RESISTANCE VALUES (Ω)	RESOLUTION (%)	OHMS PER TURN	MAXIMUM CURRENT AT 70°C AMBIENT (mA)	MAXIMUM VOLTAGE ACROSS COIL (V)	TEMP. COEF. (ppm/°C)
5	0.320	0.016	835	4.19	800
10	0.240	0.024	591	5.92	800
20	0.190	0.038	418	8.37	800
50	0.212	0.106	264	13.3	20
100	0.181	0.181	187	18.7	20
200	0.150	0.300	133	26.3	20
500	0.115	0.575	83.4	42.0	20
1K	0.103	1.03	59.1	59.2	20
2K	0.094	1.89	41.8	83.7	20
5K	0.068	3.42	26.4	133	20
10K	0.059	5.91	18.7	187	20
20K	0.048	9.52	13.2	265	20
50K	0.044	22.0	8.37	422	20