

Model 16

Spectrol

22mm Dia Fifteen Turn Dial



FEATURES

- Round Vernier Scale
- 7/8" Dia.
- 1/4" or 1/8" Shaft Adapter
- Two Set Screws
- Satin Chrome Finish with Black or White Markings
- Black Chrome Finish with White Markings
- Brushed Chrome Finish with Black Markings

MECHANICAL SPECIFICATIONS	
PARAMETER	
Mounting	Install mounting bracket between panel and panel nut. Multidial shall mount directly to shaft with No. 2 - 56 spline socket set screw, located adjacent to No. 50 on graduated dial
Numeral Size	0.75 Inches H
Graduation Size:	
Numeral	0.45 Inches L (1.14cm)
Intermediate	0.030 Inches L (0.76cm)
Weight	0.7 oz maximum (19.84gm)

OPERATIONAL SPECIFICATIONS	
Readout and Operation	15 turns total The number in the window (0 thru 14) indicates completed number of turns of the drive sleeve. Graduated circular dial indicates the percent of the partial turn of the drive sleeve
Transfer Point	The number in center of window shall change as graduated dial rotates between 95 and 0
Rotation	Readout shall increase with clockwise and decrease with counterclockwise rotation
Brake Lever	1st position (15" movement of brake lever) operates a high torque system for fine adjustment; 2nd position (15° additional movement of brake lever) actuates brake
Accuracy	Zero backlash between graduated dial and the drive sleeve

DIMENSIONS in inches (millimeters)

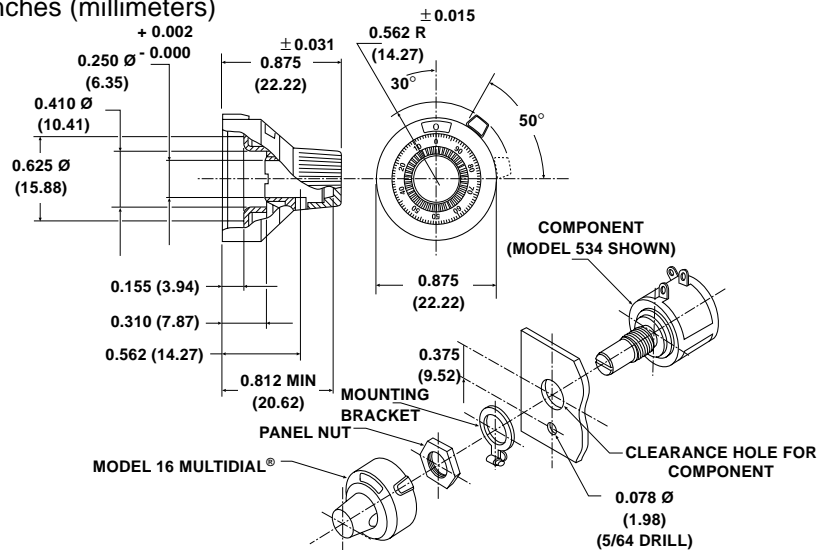

ORDERING INFORMATION		
16 MODEL	1 SHAFT DIAMETER ACCOMMODATION AND FIXINGS	11 FINISH
Example: 16 - 1 - 11	<ol style="list-style-type: none"> 1/4 Dia. shaft - 1 set screw 1/4 Dia. shaft - 2 set screws 1/8 Dia. shaft - 1 set screw 1/8 Dia. shaft - 2 set screws 	<ol style="list-style-type: none"> 11. Satin chrome, black markings (standard) 21. Black chrome, white markings 31. Brushed chrome, black markings 41. Satin chrome, white markings