

# P16, PA16

Sfernice

## Potentiometer Knobs



**P16P - PA16P**  
Plastic knob



**P16 - PA16**  
Metallic knob

The P16 is a revolutionary concept in panel mounted potentiometers. This unique design consists of a knob driving and incorporating a cermet potentiometer. Only the mounting hardware and terminals are situated on the back side of the panel reducing to a minimum the required clearance.

### FEATURES

- 1 Watt at 40°C
- CECC 41300
- **P16 - P16P** version for professional and industrial applications
- **PA16 - PA16P** version for professional audio applications
- Compact (integrated knob)
- Minimum clearance requirement
- Safety in use due to good insulation:  $\geq 10^4 M\Omega$  500V<sub>DC</sub>
- High dielectric strength : 2500 V<sub>RMS</sub>
- Hermetically sealed and panel sealed

### DIMENSIONS in millimeters

#### P16 - PA16

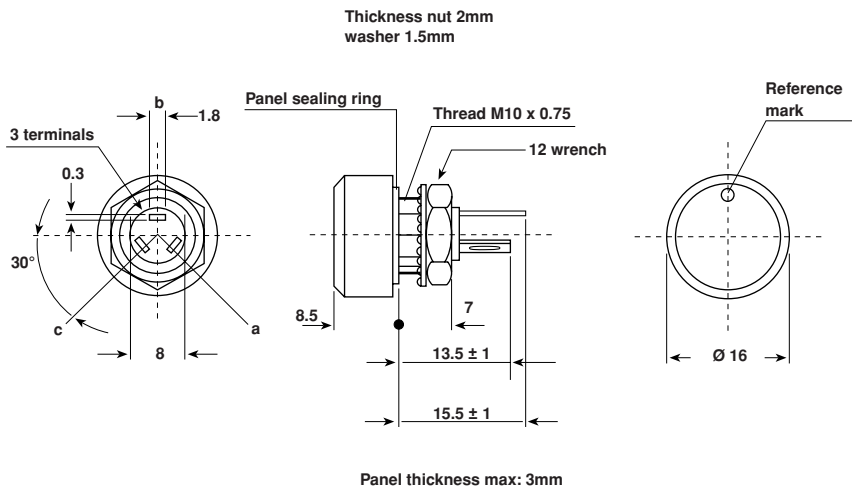

#### PANEL CUTOUT

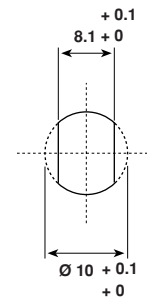

### CIRCUIT DIAGRAM

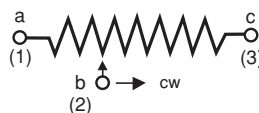

ELECTRICAL SPECIFICATIONS		
	P16	P16P
Resistive Element	cermet	
Electrical Travel	270° ± 10°	
Resistance Range		
Linear Law	22Ω to 10MΩ	
Logarithmic Laws	100Ω to 2.2MΩ	
Standard Series E3	1 - 2.2 - 4.7 and on request: 1 - 2 - 5	
Tolerance	Standard	± 20%
	On Request	± 10%
Power Rating	Linear	1 W at + 40°C
	Logarithmic	0.5 W at + 40°C
Temperature Coefficient	See Standard Resistance Element Data	
Dielectric Strength (RMS)	2500V	
Limiting Element Voltage (Linear Law)	350V	
Insulation Resistance (500 VDC)	≥10 <sup>4</sup> MΩ	
Contact Resistance Variation	3% Rn or 3Ω	
End Resistance (Typical)	1Ω	
Insulation Resistance (500 VDC)	10 <sup>6</sup> MΩ	

PLASTIC MATERIALS USED ARE UL 94 class VO

**P16 - P16P CHARACTERISTICS**

**MECHANICAL SPECIFICATIONS**

Mechanical Travel	300° ± 5°
Operating Torque (Ncm)	2 typical
End Stop Torque (max. Ncm)	25
Max. Tightening Torque Of Mounting Nut (Ncm)	250
Unit Weight	4.5 g typical

**ENVIRONMENTAL SPECIFICATIONS**

	P16	P16P
Temperature Range	- 55°C + 125°C	- 55°C + 85°C
Climatic Category	55/100/56	55/70/56
Sealing	sealed container and panel sealed	
Protection Grades	IP67	

**POWER RATING CHART**

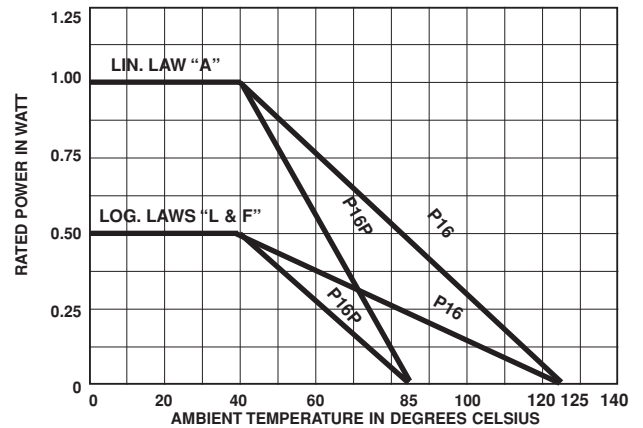

**RESISTANCE LAWS**

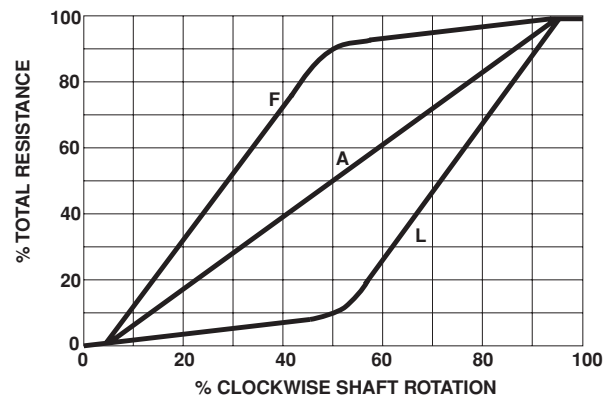

PERFORMANCE			
TESTS	CONDITIONS	TYPICAL VALUES AND DRIFTS	
		$\frac{\Delta RT}{RT}$ (%)	$\frac{\Delta R_{1-2}}{R_{1-2}}$ (%)
Load Life	1000 hours Pn 90°/30° at 40°C	± 1%	Contact resistance variation : < 3% Rn
Climatic Sequence	Phase A dry heat 85°C/125°C Phase B damp heat Phase C cold -55°C Phase D damp heat 5 cycles	± 0.5%	± 1%
Humidity	56 days	± 0.5%	Insulation resistance : > 10 <sup>4</sup> MΩ
Temperature Variations	5 cycles - 55°C to 85°C/125°C	± 0.5 %	
Shock	50 g 11 ms 3 successive shocks in 3 directions	± 0.1%	± 0.2%
Vibration	10 - 55 Hz 0.75 mm or 10 g during 6 hours	± 0.1%	± 0.2%
Rotational Life	25000 cycles	± 3 %	Contact resistance variation : < 2% Rn

STANDARD RESISTANCE ELEMENT DATA							
STANDARD RESISTANCE VALUES	LINEAR LAW			LOG LAWS			T.C. - 40°C + 85°C
	MAX. POWER AT 40°C	MAX. WORKING VOLTAGE	MAX. CUR. THROUGH ELEMENT	MAX. POWER AT 40°C	MAX. WORKING VOLTAGE	MAX. CUR. THROUGH ELEMENT	
Ω	P1 (W)	Um = √P1xRn 350 VDC	Im (mA)	P1 (W)	Um = √P1xRn 350 Vdc	Im (mA)	10 <sup>-6</sup> °C
22	1	4.69	213.2				- 50
47		6.85	145.8				+ 200
100		10	100				
220		14.83	67.4				
470		21.67	46.1				
1k		31.62	31.6	0.5	22.4	22.4	
2.2k		46.90	21.32		33.2	15.1	
4.7k		68.55	14.58		48.5	10.3	
10k		100	10		70.7	7.07	
22k		148.32	6.74		105	4.77	± 100
47k		216.7	4.61		153	3.26	
100k	1	316.23	3.16		224	2.24	
220k	0.56	350	1.59	0.5	332	1.51	
470k	0.26	350	0.75	0.26	350	0.74	
1M	0.12	350	0.35	0,12	350	0.35	
2.2M	0.05	350	0.16				
4.7M	0.02	350	0.07				
10M	0.01	350	0.012				

### CONTROL KNOB

Black metallic knob (N).

Black plastic knob (NP).

For white and blue color see ordering information.

Other dimensions, shapes, colours of control knobs are manufactured on request - please consult VISHAY.

Other reference marks (shapes, colours) and legends can be printed on plastic knob on request - please consult VISHAY.

### MARKING

Printed : VISHAY trademark, ohmic value, tolerance (in %), resistance law, manufacturing date.

### PACKAGING

Carton box of 20 pieces.

**PROFESSIONAL AUDIO APPLICATIONS PA16 - PA16P**

The industrial cermet track is replaced by a **conductive plastic** track especially selected for its performance characteristics in relation to audio functions.

**PA16 - PA16P SPECIFICATIONS**

ELECTRICAL SPECIFICATIONS		
	PA16	PA16P
Resistive Element	conductive plastic	
Resistance Range PA16	A law 1kΩ to 1MΩ L, F laws 470Ω to 500kΩ	
Tolerance	Standard	± 20%
	On Request	± 10% (1kΩ to 100kΩ)
Power Rating	0.5 W at 40°C	
Temperature Coefficient	± 1000 ppm/°C	
Contact Resistance Variation Law A	2% Rn	
Limiting Element Voltage	350V	

**MECHANICAL SPECIFICATIONS**

Rotational Life 50000 cycles

**ENVIRONMENTAL SPECIFICATIONS**

Temperature Range - 25°C to + 85°C  
 Climatic Category 25/85/56  
 Sealing sealed container and panel sealed IP67

PA16-PA16P PARTICULAR CHARACTERISTICS					
NOMINAL RESISTANCE	LAWS A, L, F			T.C. - 25°C + 100°C	
	MAXIMUM DISSIPATION AT 40°C	MAXIMUM VOLTAGE	MAX. CUR. THROUGH THE WIPER		
Ω	W	V	mA	ppm/°C	
1k	0.5	22.4	22.4	± 1000	
2.2k	↓	33.2	15.1		
4.7k		48.5	10.3		
10k		79.7	7.07		
22k		105	4.77		
47k		153	3.26		
100k		224	2.24		
220k		0.5	332		1.51
470k		0.26	350		0.74

PA16 PERFORMANCE		
TESTS	CONDITIONS	TYPICAL VALUES AND DRIFTS
		$\frac{\Delta R_{ac}}{R_{ac}}$ (%) $\frac{\Delta R_{ac}}{R_{ac}}$ (%)
Long Term Damp Heat	56 days	± 2% Insulation resistance : > 10 <sup>4</sup> MΩ
Load Life	1000 hours at Pn 90°/30° cycle at + 40°C	± 5% Insulation resistance : > 10 <sup>4</sup> MΩ Contact resistance variation : < 2% Rn
Shock	50 g 11 ms 3 successive shocks in three axes	± 0.2%      ± 0.5%
Vibration	10 - 55 Hz 0.75 mm or 10 g during 6 hours	± 0.2% $\frac{\Delta V_{ab}}{V_{ac}} \leq \pm 0.5\%$
Rotational Life	50000 cycles	± 5% Contact resistance variation : < 2% Rn

ORDERING INFORMATION					
P16, PA16	NP	22 kΩ	± 20 %	A	BO20
SERIES	CONTROL KNOB DESIGNATION	OHMIC VALUE	TOLERANCE	LAW	PACKAGING
	N : metallic black color NP : plastic black color W : metallic white color WP : plastic white color BP : plastic blue color			A : linear L : clockwise logarithmic F : inverse clockwise logarithmic	