



Features

- Compact, requires only 22.7mm diameter panel space
- No backlash
- For use with precision potentiometers or other rotating devices up to 15 turns
- Plastic shaft

BOURNS®

H-506 Turns-Counting Dial

Mechanical and Physical Characteristics

Number of Turns	0 to 15
Dial Divisions50 per turn
Readability - Over 10 Turns	2 parts in 1000
Torque With Brake Engaged	7.0 oz-in. (5.0 Ncm) minimum
Weight	7 grams
Markings	White on black background
Set Screws	2 screws 120° apart

Shaft and Bushing Requirements

Shaft Extension Beyond Panel	0.6890 in. minimum (17.5 mm)
	0.8858 in. maximum (22.5 mm)
Bushing Extension Beyond Panel	0.3937 in. maximum (10 mm)

FEATURES

- For use with precision potentiometers or other rotating devices up to 15 turns
- Excellent legibility - white marking on black background
- High quality, rugged construction
- Two set screws
- No backlash
- High force, positive brake
- Compact - requires only .9" (22.86mm) diameter panel space
- Standard models to fit 1/4" and 6mm diameter shafts

H-506 MOUNTING INSTRUCTIONS

1. Drill .0787 (2.0) diameter anti-rotation pin hole on vertical centerline, .375 (9.5mm) below center of potentiometer mounting hole.
2. Mount potentiometer in panel with nut and lockwasher supplied with the potentiometer.
3. Turn potentiometer shaft counterclockwise to obtain minimum resistance or voltage ratio. This is not necessarily identical with mechanical stop.
4. Loosen set screws in knob of dial. Set dial to "0.0" reading.
5. While holding outer ring of dial, position unit lightly against panel. Tighten knob set screws to potentiometer shaft.

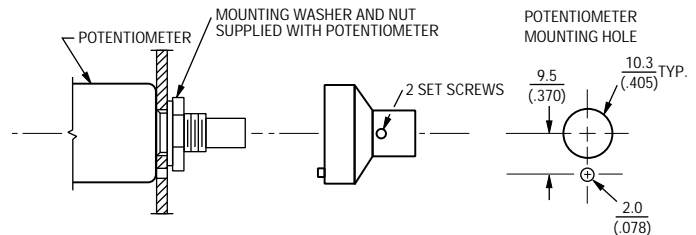

Dimensional Drawings

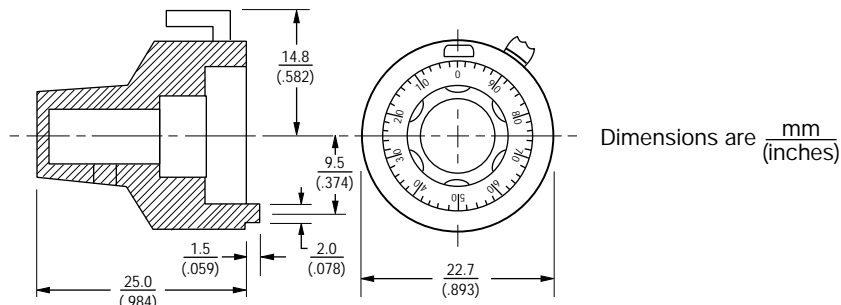

Shaft Diameter

Part Number	Accepts Shaft Diameter
H-506-1/4	6.35mm (.250)
H-506-6M	6mm (.236)