



Features

- 6mm Round / Single-Turn / Cermet Industrial / Open Frame
- Cross slot adjustment options
- Horizontal and vertical mounting styles
- Dust resistant/splash resistant covers
- PC board stand-offs and retention feature

- Front and top adjust styles

3306 - 6mm Round Trimming Potentiometer

Electrical Characteristics

Standard Resistance Range100 to 1 megohm
 (see standard resistance table)
 Resistance Tolerance±25% std.
 Absolute Minimum Resistance2% max. ($\leq 2K = 30$ ohms)
 Contact Resistance Variation ...3% max.
 Resolution.....Infinite
 Adjustment Angle215° nom.

Environmental Characteristics

Power Rating (100 volts max.)
 70°C0.2 watt
 Temperature Range-25°C to +100°C
 Temperature Coefficient±250ppm/°C
 Load Life ..1,000 hours 0.2 watt @ 70°C
 (5% ΔTR)

Physical Characteristics

Mechanical Angle.....260° ±20°
 Torque (Operating).....4.5 oz-in. max.
 Stop Strength6.5 oz-in. min.
 TerminalsSolderable pins
 MarkingManufacturer's trademark, resistance code
 Standard Packaging300 pcs. per bag
 Adjustment ToolH-90
 Aqueous cleaning not recommended

How To Order

3306 W - 1 - 103

Model _____
 Style _____
 Standard Product _____
 Resistance Code _____

Standard Resistance Table

| Resistance (Ohms) | Resistance Code |
|-------------------|-----------------|
| 100 | 101 |
| 200 | 201 |
| 500 | 501 |
| 1,000 | 102 |
| 2,000 | 202 |
| 5,000 | 502 |
| 10,000 | 103 |
| 20,000 | 203 |
| 25,000 | 253 |
| 50,000 | 503 |
| 100,000 | 104 |
| 200,000 | 204 |
| 250,000 | 254 |
| 500,000 | 504 |
| 1,000,000 | 105 |

Popular values listed in boldface. Special resistances available.

SHADED AREA NOT TYPICALLY STOCKED BY DISTRIBUTORS AND NOT RECOMMENDED FOR NEW DESIGNS.

Top Adjust Common Dimensions

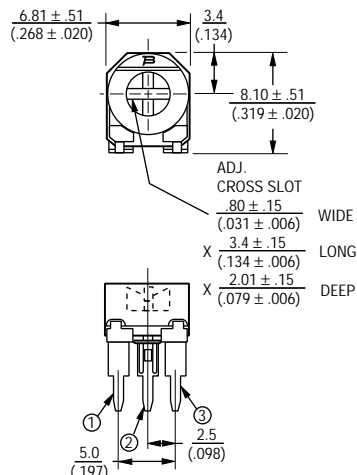

3306P

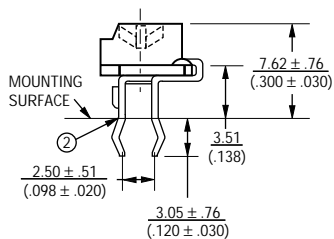

3306F

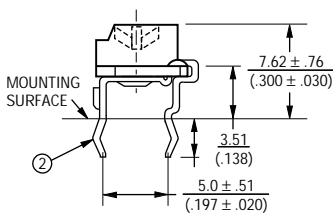

SUGGESTED PWB LAYOUT - STYLE F

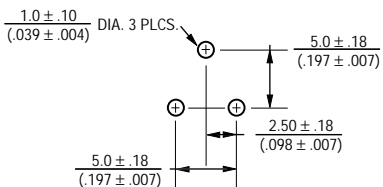

Side Adjust Common Dimensions

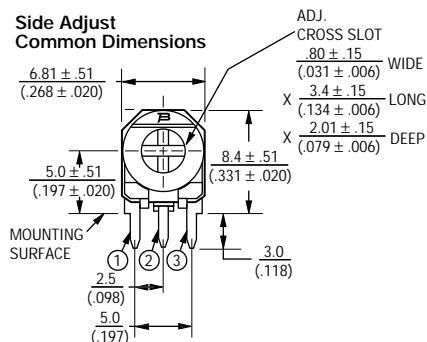

3306W

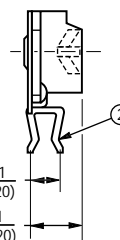

3306K

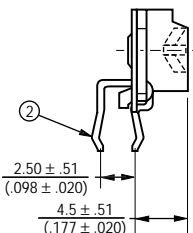

SUGGESTED PWB LAYOUT - STYLES K, P, W

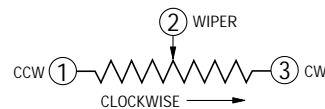
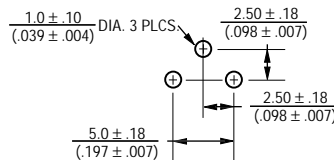

TOLERANCES: ± 0.25 (.010) EXCEPT WHERE NOTED

DIMENSIONS ARE: METRIC (INCHES)