

AVAILABLE THROUGH DISTRIBUTION

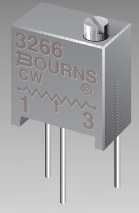

BOURNS®

Features

- Multiturn / Cermet / Industrial / Sealed
- Standoffs allow thorough PC board washing
- Tape and reel packaging available (see page 70 for details)
- Patent #4427966 drive mechanism

3266 - 1/4" Square Trimming Potentiometer

Electrical Characteristics

Standard Resistance Range 10 to 1 megohm
 (see standard resistance table)
 Resistance Tolerance ±10% std.
 Absolute Minimum Resistance 1% or 2 ohms max.
 (whichever is greater)
 Contact Resistance Variation 3.0% or 3 ohms max.
 (whichever is greater)
 Adjustability
 Voltage ±0.02%
 Resistance ±0.05%
 Resolution Infinite
 Insulation Resistance 500 vdc.
 1,000 megohms min.
 Dielectric Strength
 Sea Level 600 vac
 80,000 Feet 250 vac
 Effective Travel 12 turns nom.

Environmental Characteristics

Power Rating (300 volts max.)
 70°C 0.25 watt
 150°C 0 watt
 Temperature Range -55°C to +150°C
 Temperature Coefficient ±100ppm/°C
 Seal Test 85°C Fluorinert*
 Humidity MIL-STD-202 Method 103
 96 hours (2% ΔTR, 10 Megohms IR)
 Vibration 30G (1% ΔTR; 1% ΔVR)
 Shock 100G (1% ΔTR; 1% ΔVR)
 Load Life 1,000 hours 0.25 watt 70°C
 (3% ΔTR; 3% CRV)
 Rotational Life 200 cycles
 (4% ΔTR; 3% or 3 ohms, whichever is greater, CRV)

Physical Characteristics

Torque 3.0 oz-in. max.
 Mechanical Stops Wiper idles
 Terminals Solderable pins
 Weight 0.015 oz.
 Marking Manufacturer's trademark, resistance code, wiring diagram, date code, manufacturer's model number and style
 Wiper Positioned at 50% nominal
 Flammability U.L. 94V-0
 Standard Packaging 50 pcs. per tube
 Adjustment Tool H-90

*"FLUORINERT" IS A REGISTERED TRADEMARK OF 3M CO.

3266W Common Dimensions

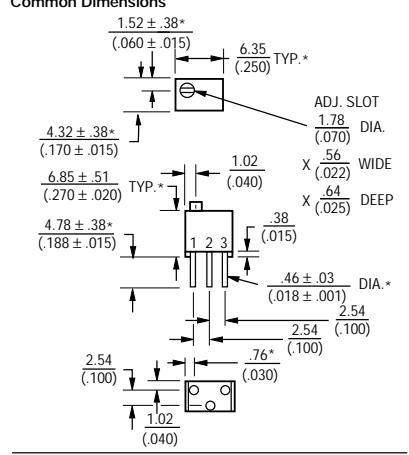

3266P

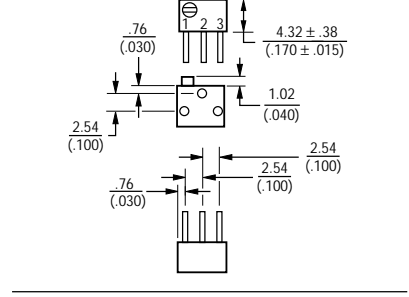

3266X

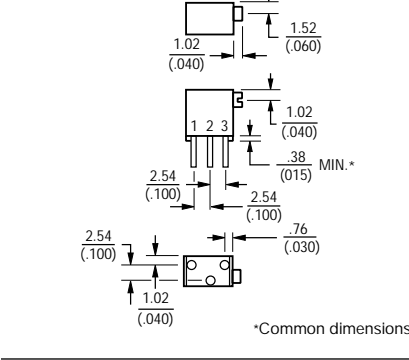

TOLERANCES: ± 0.25 (.010) EXCEPT WHERE NOTED
 DIMENSIONS ARE: METRIC (INCHES)

How to Order

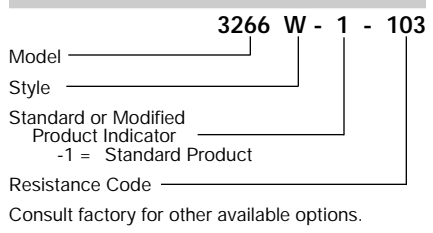

3266Y

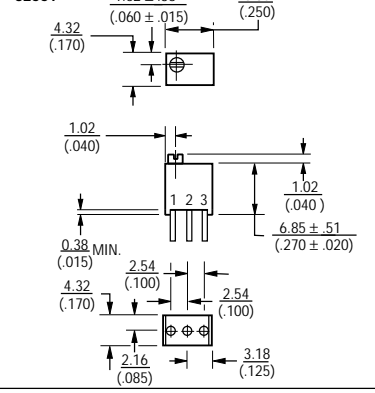

3266Z

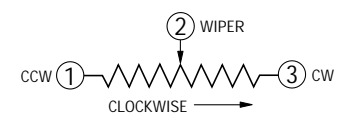
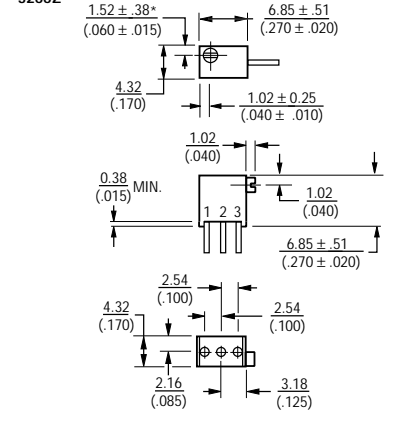

Standard Resistance Table

Resistance (Ohms)	Resistance Code
10	100
20	200
50	500
100	101
200	201
500	501
1,000	102
2,000	202
5,000	502
10,000	103
20,000	203
25,000	253
50,000	503
100,000	104
200,000	204
250,000	254
500,000	504
1,000,000	105

Popular values listed in boldface. Special resistances available.
 SHADED AREAS TYPICALLY NOT STOCKED BY DISTRIBUTORS AND NOT RECOMMENDED FOR NEW DESIGNS.