

30JB

Nomenclature

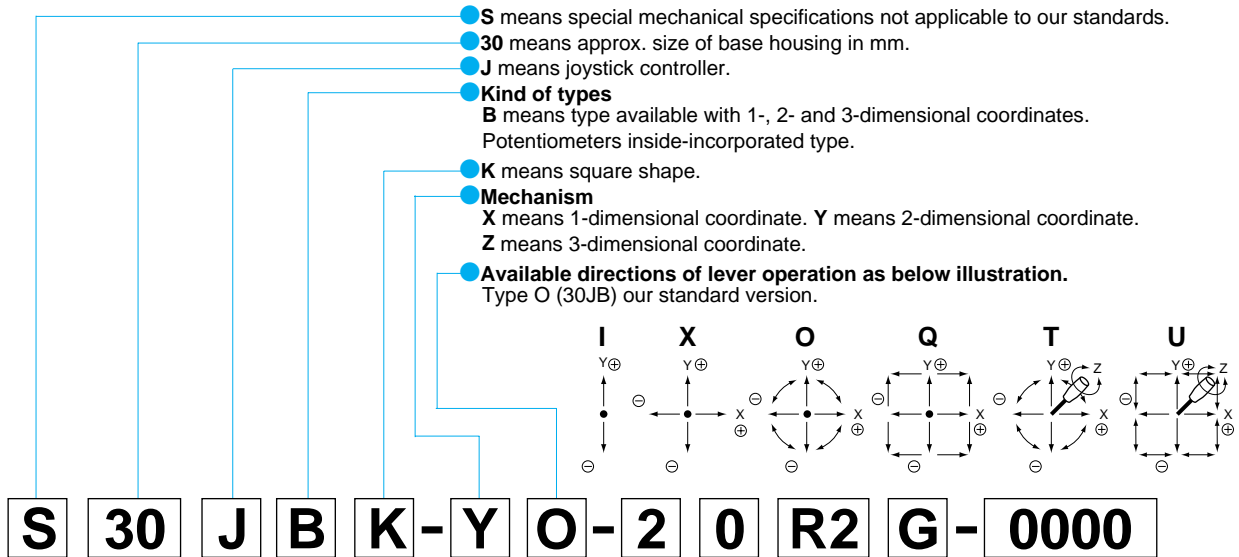

Number of potentiometers to be mounted only for 30JBK.

- 0...no potentiometer mounted. 1...1 potentiometer mounted.
- 2...2 potentiometers mounted. 3...3 potentiometers mounted.

Number of switches to be mounted.

- 0...no switch mounted. 1...1 switch mounted.
- 2...2 switches mounted.

With spring return device : R1: with spring return device for 1-dimensional coordinate.

R2: with spring return device for 2-dimensional coordinate.

R3: with spring return device for 3-dimensional coordinate.

Mounting accessories : G: with dust proof rubber cover. P: with sub-panel for mounting.

Special part number basing on customer's specifications with 4 digits number.

Standard Dimensions

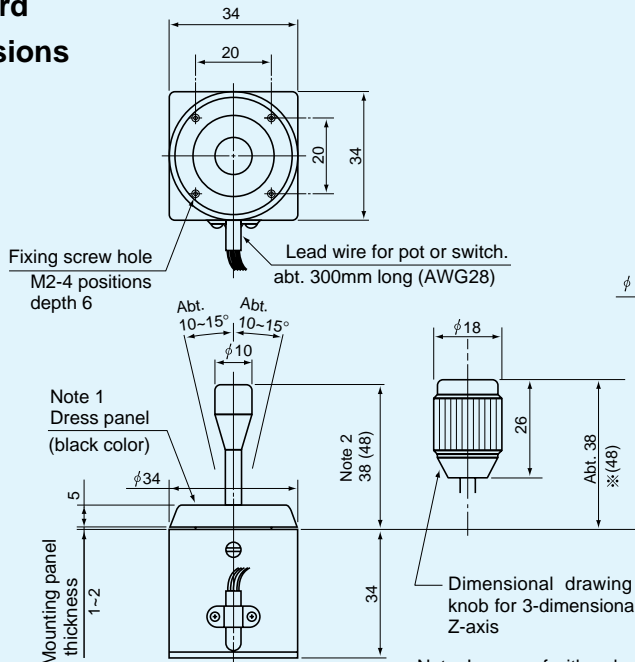

Panel Arrangements

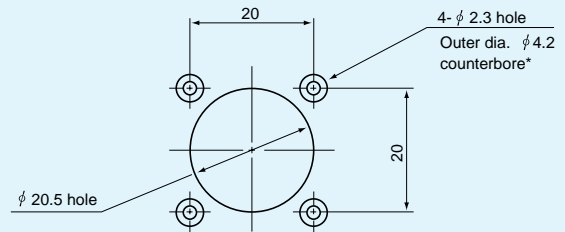

- Note: 1) In case of with a dust-proof rubber cover, the counterbore-work (*part) is not necessary.
- 2) 4 pcs. of mounting screws (M2 \times 6) are attached.

Note: In case of with a dust-proof rubber cover, the shape of dress panel shall change.

※ Numeral in parentheses shows that of with a dust-proof rubber cover.

(Unit : mm)



30JBK-YO-20R2

(standard)

(2-dimensional coordinate type)



30JBK-ZT-30R3

(standard)

(3-dimensional coordinate type)

STANDARD SPECIFICATIONS

Model 30JB Series
(Potentiometer inside-incorporated type)

●Mechanical Performances

Controlling range of operating lever :

X and Y directions : Approx. $\pm 10^\circ \sim \pm 15^\circ$ from center position. (Omni-directionally)
Z direction : Approx. $\pm 30^\circ \sim \pm 35^\circ$ from center position.

Operating force (With standard automatically center returning spring return device) (Omni-directionally)

X and Y directions : Approx. 0.8~2N (80~200gf)
Z direction : Approx. 15~60mN·m (150~600gf·cm)

Operating temperature range : $-20^\circ\text{C} \sim +65^\circ\text{C}$

Vibration : 10~55Hz 98m/s² (10G)

Shock : 294m/s² (30G)

Life expectancy : Approx. 5,000,000 operations

Mass : 2-dimensional coordinate type : Approx. 80g
3-dimensional coordinate type : Approx. 100g

●Electrical Performances

Potentiometers mounted : Special conductive plastic resistive element exclusively used for 30JB series is incorporated.

(X and Y axes pots)
Resistance value : $10\text{k}\Omega \pm 15\%$

Rating : 0.1W

Electrical rotating angle : Approx. 20°
Independent linearity tolerance : $\pm 3\%$

(Z axis pot.)
Resistance value : $10\text{k}\Omega \pm 15\%$

Rating : 0.04W

Electrical rotating angle : Approx. 60°
Independent linearity tolerance : $\pm 3\%$

Output smoothness : Below 0.2% against input voltage

Contact resistance variation : Below 6% C.R.V

Resolution : Essentially infinite

Dielectric strength : 1 minute at 500V.A.C.

Insulation resistance : Over 1,000M Ω at 500V.D.C.

●Terminal Connection Diagram

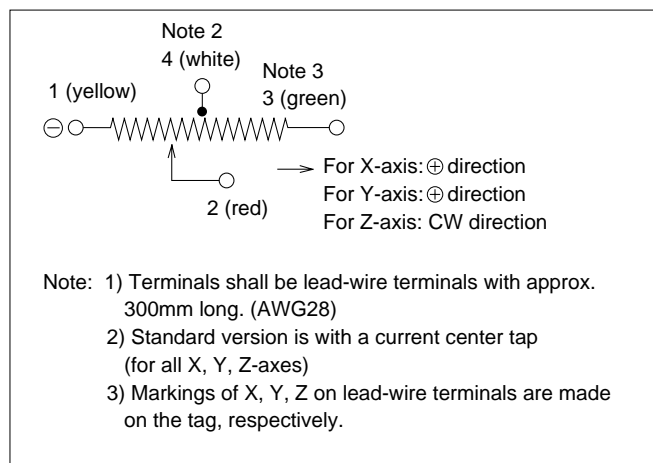

●Special Specifications Available

Please see page 41, a table of "Standard and Special Specifications Available".