



UM3561

Three Siren Sound Generator

Features

- Four sounds can be selected
- Typical 3V operation voltage
- RC oscillator with an external resistor or an oscillator/resistor is built-in. (mask option)
- A magnetic speaker can be driven by connecting an NPN transistor
- Power on reset

General Description

The UM3561 is a lowcost, low-power CMOS LSI designed for use in toy applications. Since the integrated circuit includes oscillator and selector circuits, a compact sound

module can be constructed with only a few additional components. The UM3581 contains a programmed mask ROM to simulate siren sounds.

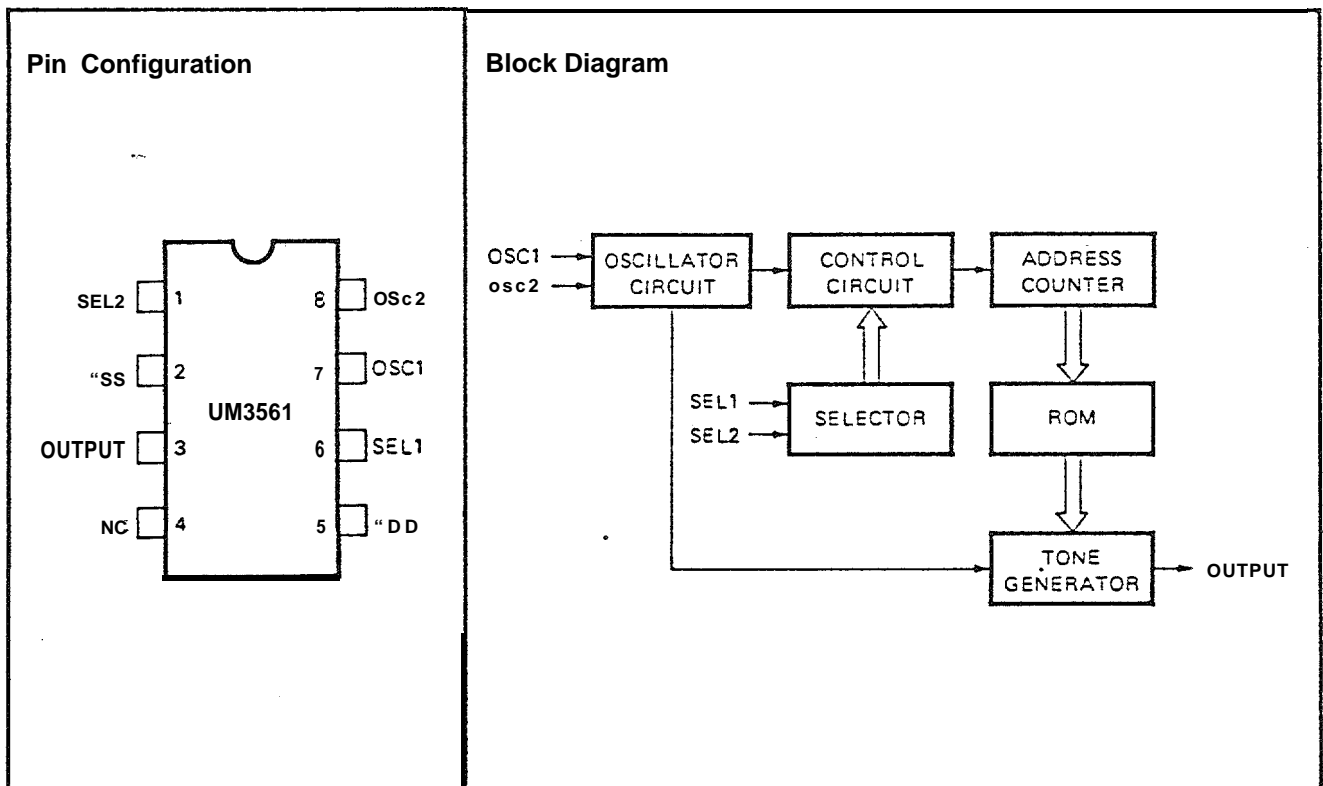

Absolute Maximum Ratings*

DC Supply Voltage -0.3V to +5.0V
 Input/Output Voltage $V_{SS} - 0.3V$ to $V_{DD} + 0.3V$
 Operating Ambient Temperature -10°C to 60°C
 Storage Temperature -55°C to 125°C

***Comments**

Stresses above those listed under "Absolute Maximum Ratings" may cause permanent damage to the device. These are stress ratings only. Functional operation of this device at these or any other conditions above those indicated in the operational sections of this specification is not implied and exposure to absolute maximum rating conditions for extended periods may affect device reliability.

Electrical Characteristics ($V_{SS} = 0V$, $T_A = 25^\circ C$, $F_{OSC} = 106496$ Hz, unless otherwise specified.)

| Parameter | Symbol | Min. | TYP. | Max. | Conditions |
|-----------------------------|--------------|----------------|------|----------------|---|
| Operating Voltage | V_{DD} | 2.4V | 3v | 3.6V | |
| Operating Current | I_{DD} | - | - | 150µA | $V_{DD} = 3V$ |
| "H" input Voltage | V_{IH} | $V_{DD} - 0.2$ | - | V_{DD} | |
| "L" Input Voltage | V_{IL} | V_{SS} | - | $V_{SS} + 0.2$ | |
| Frequency Stability | $\Delta F/F$ | | | 20% | $\frac{F_{OSC}(3.3V) - F_{OSC}(2.7V)}{F_{OSC}(2.7V)}$ |
| Output Current | I_O | 3mA | | - | $V_{DD} = 3V$ |
| Frequency Deviation Per Lot | $\Delta F/F$ | -10% | | +10% | $V_{DD} = 3V$ |

Pin Description

| Pin No. | Designation | Description |
|---------|-------------|--|
| 1 | SEL 2 | Sound effect selection pin |
| 2 | V_{SS} | Negative power supply |
| 3 | OUTPUT | Mono-tone output |
| 4 | NC | This pad is used for testing; in normal operation, this pad is open. |
| 5 | V_{DD} | Positive power supply |
| 6 | SEL 1 | Sound effect selection pin |
| 7 | OSC 1 | RC oscillator pin |
| 8 | osc2 | RC oscillator pin or inverted clock output |

Functional Description

Oscillating circuit

There are two Options for generating oscillator frequency. Either can be selected by changing the mask.

(1) Only one external resistor is required to complete

the oscillator frequency.

(2) Oscillator resistor is built-in

Sound Selection

The SEL2 incorporates a resistor for internal pull low, and SEL1 is a tri-state control pin. 2 pads, SEL1 and SEL2, should be selected for the sound effect mode.

Sound Effect ROM

The sound effect ROM is organized as 256 words by 8 bits. The sound effect program and the option are mask programmable and programmed in the N⁺ layer.

| Bonding Pad | | Sound Effect |
|-----------------|-----------------|-------------------|
| SEL 1 | SEL 2 | |
| No Connection | No Connection | Police Siren |
| V _{DD} | No Connection | Fire engine siren |
| V _{SS} | No Connection | Ambulance siren |
| "—" don't care | V _{DD} | Machine gun |

Typical Application
FOUR SOUND APPLICATION

1. Police Siren 2. Fire Engine Siren 3. Ambulance Siren 4. Machine Gun

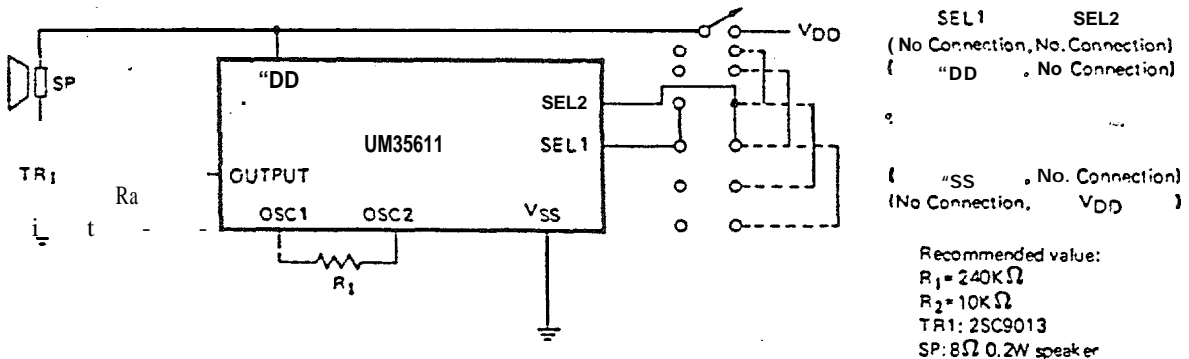

THREE SOUND APPLICATION

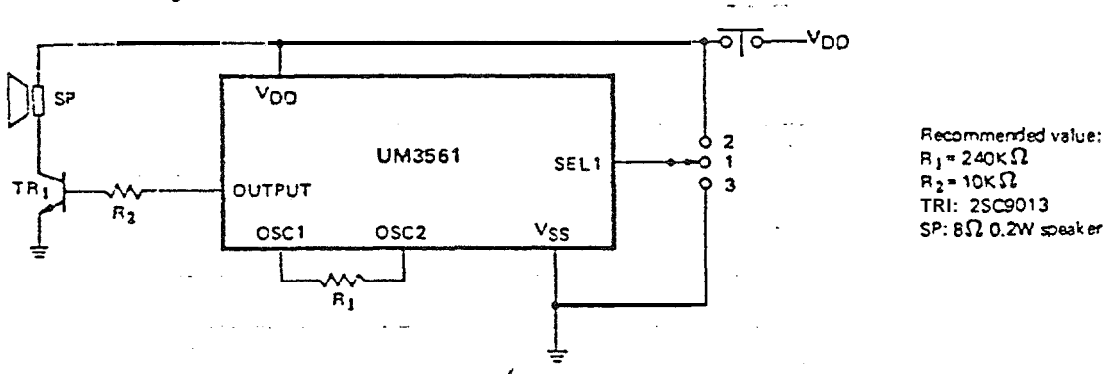
1. Police Siren 2. Fire Engine Siren 3. Ambulance Siren

TWO SOUND APPLICATION

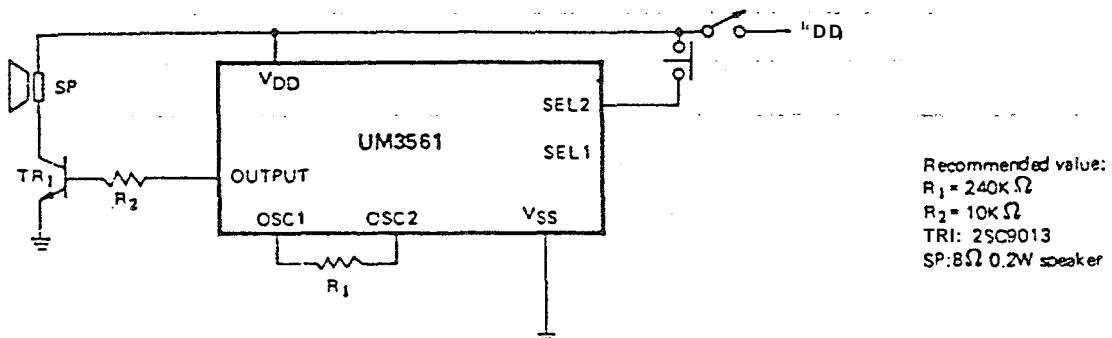
1. Police Siren 2. Machine Gun

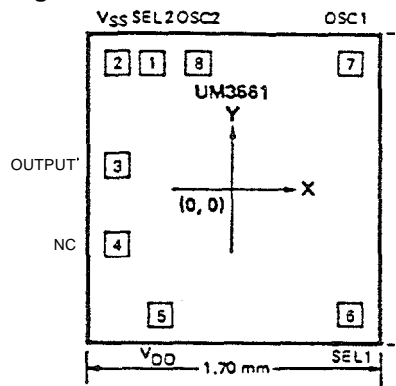

Bonding Diagram

| Pad No. | Designation | unit: μm | |
|---------|-----------------|---------------------|---------|
| | | X | Y |
| 1 | SEL2 | -256.70 | 777.24 |
| 2 | V _{SS} | -515.62 | 777.24 |
| 3 | OUTPUT | -698.53 | 172.72 |
| 4 | NC | -698.50 | -370.84 |
| 5 | V _{DD} | -482.60 | -767.08 |
| 6 | SEL1 | 690.88 | -762.00 |
| 7 | OSC1 | 698.50 | 777.24 |
| 8 | OSC2 | -17.78 | 777.24 |