

TGS 842 - for the detection of Methane

Features:

- * High sensitivity to Methane
- * Long-term stability
- * Low sensitivity to alcohol vapors
- * Uses simple electrical circuit

Applications:

- * Domestic gas alarms for the detection of methane
- * Portable gas detectors

The sensing element of Figaro gas sensors is a tin dioxide (SnO_2) semiconductor which has low conductivity in clean air. In the presence of a detectable gas, the sensor's conductivity increases depending on the gas concentration in the air. A simple electrical circuit can convert the change in conductivity to an output signal which corresponds to the gas concentration.

The **TGS 842** has high sensitivity and selectivity to methane. Due to its low sensitivity to alcohol vapors and its low temperature/humidity dependency, the sensor can achieve good reproducibility, making it ideal for domestic gas alarms.



The figure below represents typical sensitivity characteristics, all data having been gathered at standard test conditions (see reverse side of this sheet). The Y-axis is indicated as *sensor resistance ratio* (R_s/R_o) which is defined as follows:

R_s = Sensor resistance of displayed gases at various concentrations
 R_o = Sensor resistance in 3500ppm methane

The figure below represents typical temperature and humidity dependency characteristics. Again, the Y-axis is indicated as *sensor resistance ratio* (R_s/R_o), defined as follows:

R_s = Sensor resistance at 3500ppm of methane at various temperatures/humidities
 R_o = Sensor resistance at 3500ppm of methane at 20°C and 65% R.H.

Sensitivity Characteristics:

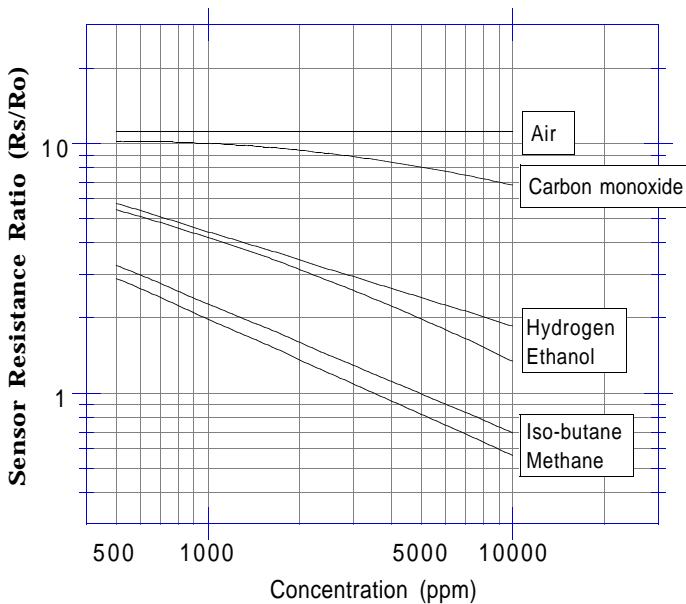

Temperature/Humidity Dependency:

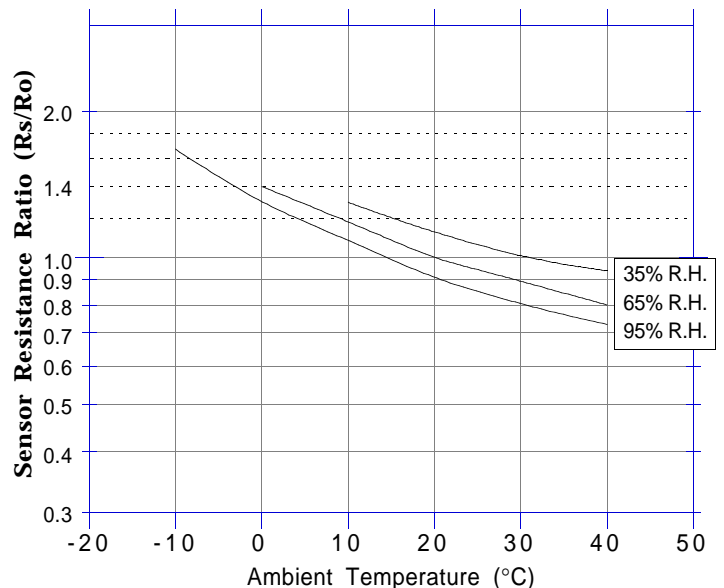

IMPORTANT NOTE: OPERATING CONDITIONS IN WHICH FIGARO SENSORS ARE USED WILL VARY WITH EACH CUSTOMER'S SPECIFIC APPLICATIONS. FIGARO STRONGLY RECOMMENDS CONSULTING OUR TECHNICAL STAFF BEFORE DEPLOYING FIGARO SENSORS IN YOUR APPLICATION AND, IN PARTICULAR, WHEN CUSTOMER'S TARGET GASES ARE NOT LISTED HEREIN. FIGARO CANNOT ASSUME ANY RESPONSIBILITY FOR ANY USE OF ITS SENSORS IN A PRODUCT OR APPLICATION FOR WHICH SENSOR HAS NOT BEEN SPECIFICALLY TESTED BY FIGARO.

Structure and Dimensions:

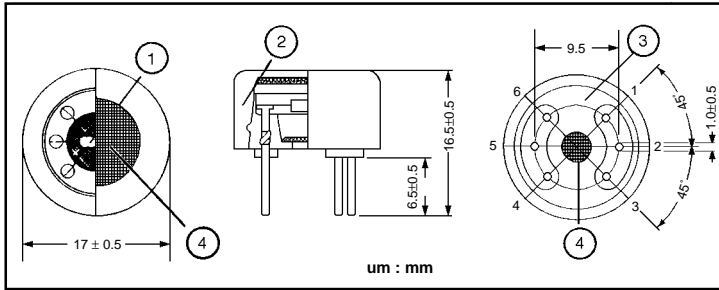

- ① Sensing Element:
SnO₂ is sintered to form a thick film on the surface of an alumina ceramic tube which contains an internal heater.
- ② Cap:
Nylon 66
- ③ Sensor Base:
Nylon 66
- ④ Flame Arrester:
100 mesh SUS316 double gauze

Pin Connection and Basic Measuring Circuit:

The numbers shown around the sensor symbol in the circuit diagram at the right correspond with the pin numbers shown in the sensor's structure drawing (above). When the sensor is connected as shown in the basic circuit, output across the Load Resistor (V_{RL}) increases as the sensor's resistance (R_s) decreases, depending on gas concentration.

Basic Measuring Circuit:

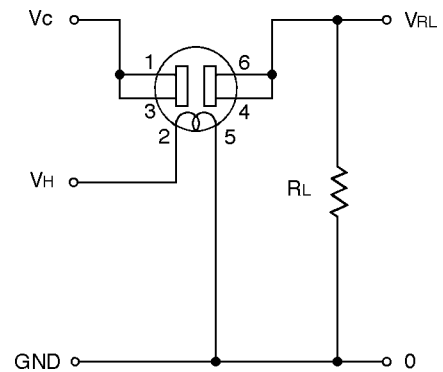

Standard Circuit Conditions:

Item	Symbol	Rated Values	Remarks
Heater Voltage	V _H	5.0±0.2V	AC or DC
Circuit Voltage	V _C	Max. 24V	AC or DC *PS≤15mW
Load Resistance	R _L	Variable	*PS≤15mW

Electrical Characteristics:

Item	Symbol	Condition	Specification
Sensor Resistance	R _s	Methane at 1000ppm/Air	3kΩ ~ 15kΩ
Change Ratio of Sensor Resistance	R _s /R _o	$\frac{R_s \text{ (Methane at 3000ppm/Air)}}{R_s \text{ (Methane at 1000ppm/Air)}}$	0.55 ± 0.05
Heater Resistance	R _H	Room temperature	30.0 ± 3.0Ω
Heater Power Consumption	P _H	V _H =5.0V	835 ± 90mW

Standard Test Conditions:

TGS 842 complies with the above electrical characteristics when the sensor is tested in standard conditions as specified below:

- Test Gas Conditions: 20°±2°C, 65±5%R.H.
- Circuit Conditions: V_C = 10.0±0.1V (AC or DC),
V_H = 5.0±0.05V (AC or DC),
R_L = 4.0kΩ±1%
- Preheating period before testing: More than 7 days

Sensor Resistance (R_s) is calculated by the following formula:

$$R_s = \left(\frac{V_C}{V_{RL}} - 1 \right) \times R_L$$

Power dissipation across sensor electrodes (P_s) is calculated by the following formula:

$$P_s = \frac{V_C^2 \times R_s}{(R_s + R_L)^2}$$