

TGS 2602 - for the detection of Air Contaminants

Features:

- * High sensitivity to VOCs and odorous gases
- * Low power consumption
- * High sensitivity to gaseous air contaminants
- * Long life
- * Uses simple electrical circuit
- * Small size

Applications:

- * Air cleaners
- * Ventilation control
- * Air quality monitors
- * VOC monitors
- * Odor monitors

The sensing element is comprised of a metal oxide semiconductor layer formed on the alumina substrate of a sensing chip together with an integrated heater. In the presence of detectable gas, sensor conductivity increases depending on gas concentration in the air. A simple electrical circuit can convert the change in conductivity to an output signal which corresponds to the gas concentration.

The **TGS 2602** has high sensitivity to low concentrations of odorous gases such as ammonia and H₂S generated from waste materials in office and home environments. The sensor also has high sensitivity to low concentrations of VOCs such as toluene emitted from wood finishing and construction products. Figaro also offers a microprocessor (FIGARO 93619A) which contains special software for handling the sensor's signal for appliance control applications.

Due to miniaturization of the sensing chip, TGS 2600 requires a heater current of only 42mA and the device is housed in a standard TO-5 package.

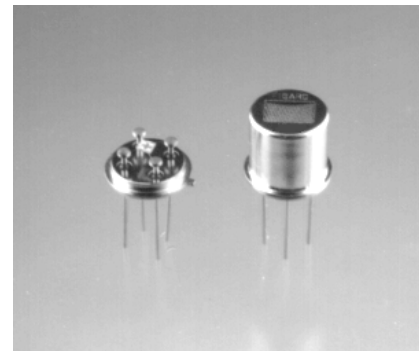

The figure below represents typical sensitivity characteristics, all data having been gathered at standard test conditions (see reverse side of this sheet). The Y-axis is indicated as *sensor resistance ratio* (R_s/R_o) which is defined as follows:

- R_s = Sensor resistance in displayed gases at various concentrations
- R_o = Sensor resistance in fresh air

The figure below represents typical temperature and humidity dependency characteristics. Again, the Y-axis is indicated as *sensor resistance ratio* (R_s/R_o), defined as follows:

- R_s = Sensor resistance in fresh air at various temperatures/humidities
- R_o = Sensor resistance in fresh air at 20°C and 65% R.H.

Sensitivity Characteristics:

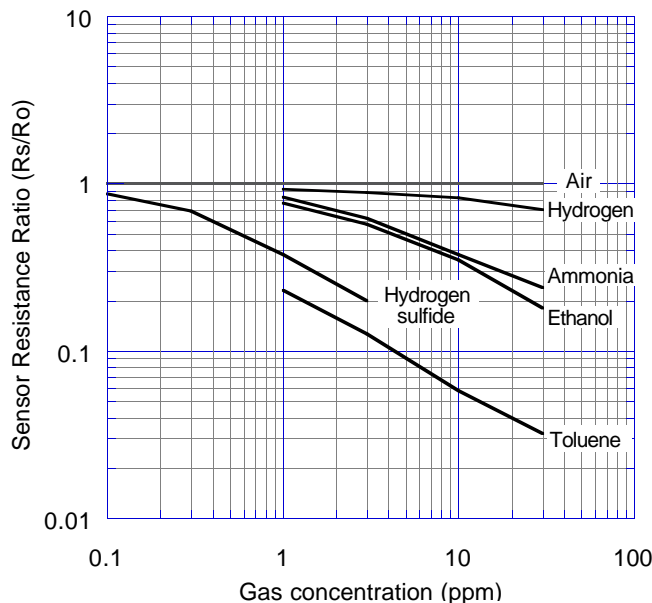

Temperature/Humidity Dependency:

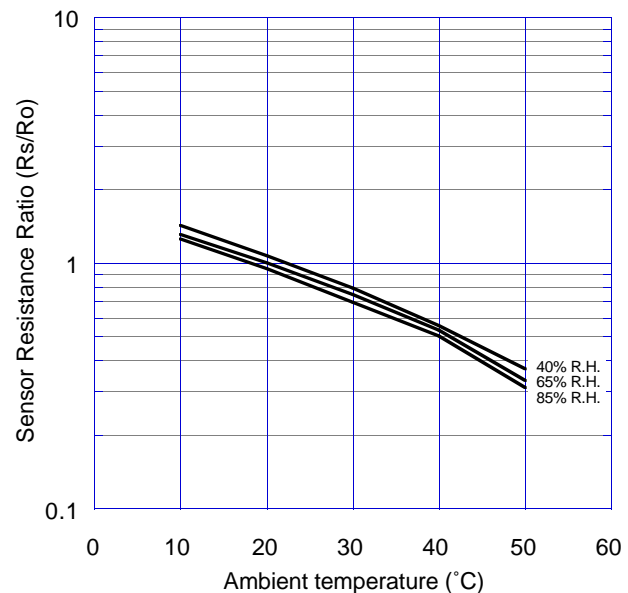

IMPORTANT NOTE: OPERATING CONDITIONS IN WHICH FIGARO SENSORS ARE USED WILL VARY WITH EACH CUSTOMER'S SPECIFIC APPLICATIONS. FIGARO STRONGLY RECOMMENDS CONSULTING OUR TECHNICAL STAFF BEFORE DEPLOYING FIGARO SENSORS IN YOUR APPLICATION AND, IN PARTICULAR, WHEN CUSTOMER'S TARGET GASES ARE NOT LISTED HEREIN. FIGARO CANNOT ASSUME ANY RESPONSIBILITY FOR ANY USE OF ITS SENSORS IN A PRODUCT OR APPLICATION FOR WHICH SENSOR HAS NOT BEEN SPECIFICALLY TESTED BY FIGARO.

Basic Measuring Circuit:

The sensor requires two voltage inputs: heater voltage (V_H) and circuit voltage (V_C). The heater voltage (V_H) is applied to the integrated heater in order to maintain the sensing element at a specific temperature which is optimal for sensing. Circuit voltage (V_C) is applied to allow measurement of voltage (V_{out}) across a load resistor (R_L) which is connected in series with the sensor. DC voltage is required for the circuit

voltage since the sensor has a polarity. A common power supply circuit can be used for both V_C and V_H to fulfill the sensor's electrical requirements. The value of the load resistor (R_L) should be chosen to optimize the alarm threshold value, keeping power consumption (P_S) of the semiconductor below a limit of 15mW. Power consumption (P_S) will be highest when the value of R_S is equal to R_L on exposure to gas.

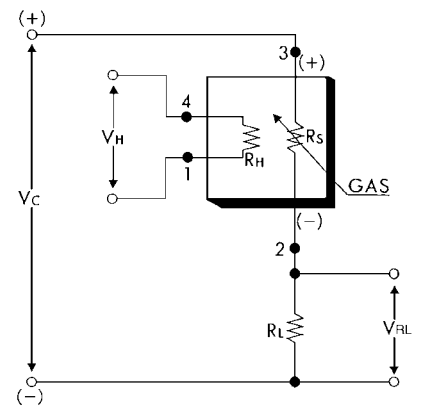

Specifications:

Model number		TGS 2602	
Sensing element type		D1	
Standard package		TO-5 metal can	
Target gases		Air contaminants	
Typical detection range		1 ~ 10 ppm of H ₂	
Standard circuit conditions	Heater voltage	V _H	5.0±0.2V DC/AC
	Circuit voltage	V _C	5.0±0.2V DC P _S ≤ 15mW
	Load resistance	R _L	Variable P _S ≤ 15mW
Electrical characteristics under standard test conditions	Heater resistance	R _H	approx. 59Ω at room temp.
	Heater current	I _H	56 ± 5mA
	Heater power consumption	P _H	280mW (typical)
	Sensor resistance	R _S	10 ~ 100 kΩ in air
	Sensitivity (change ratio of R _S)	0.15 ~ 0.5 $\frac{R_S(10ppm \text{ of EtOH})}{R_S(\text{air})}$	
Standard test conditions	Test gas conditions	normal air at 20±2°C, 65±5%RH	
	Circuit conditions	V _C = 5.0±0.01V DC V _H = 5.0±0.05V DC	
	Conditioning period before test	7 days	

Structure and Dimensions:

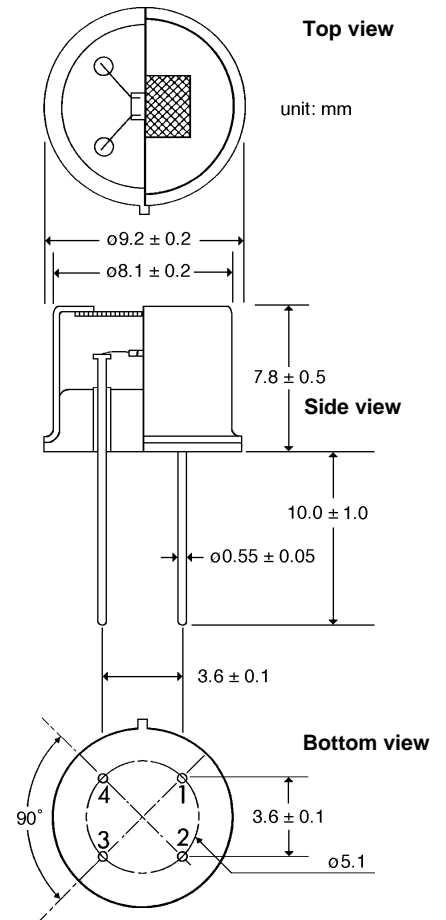

Pin connection:

- 1 : Heater
- 2 : Sensor electrode (-)
- 3 : Sensor electrode (+)
- 4 : Heater

The value of power consumption (P_S) can be calculated by utilizing the following formula:

$$P_S = \frac{(V_C - V_{out})^2}{R_S}$$

Sensor resistance (R_S) is calculated with a measured value of V_{out} by using the following formula:

$$R_S = \frac{V_C \times R_L}{V_{out}} - R_L$$