

GAS SENSORS : TYPE AF50

METHANE (CH₄) GAS SENSOR

DESCRIPTION:

Methane gas sensor made with thick film sensing element.

FEATURES:

- Constant heater voltage
- Tight resistance tolerance
- High sensitivity
- Typical applications include gas leak detection, gas appliances

DATA:

Operating conditions:

Operating temperature -10 to +55°C
Storage temperature -30 to +60°C
Load Resistor R_L Variable
Heater resistance 19Ω (nom)
Rated power consumption P_s <15mW
Rated working voltage of circuit V_c
 5V d.c. or 5V rms a.c. (max 12V)
Rated working voltage of heater
 5 ±0.2V d.c.
 5 ±0.2 V rms a.c.

Parts and material:

Sensing element Semi-conducting oxide
Thick film heater Platinum
Case Nylon 66
Pin Nickel alloy
Flame arrestor
 ... Double 100-mesh stainless gauze (SUS316)

Sensitivity characteristics:

	Specification	Conditions
Sensor resistance R_{gas}	3.0k to 12k Ω	In 2000 ppm of methane in clean air
Gas sensitivity R_{gas}/R_{air}	0.2 to 0.45	Resistance ratio at 2000ppm methane to clean air
Power consumption	690mW (max)	

Mechanical characteristics:

Test	Condition	Performance
Vibration	Frequency: 10 - 500 Hz Amplitude (10 - 50Hz): 2 mm Acceleration (50 - 500 Hz) 10G Reciprical scanning time: 5 min Test time: 2 hours each for X, Y and Z directions	Should satisfy the specifications shown in the sensitivity characteristics
Shock	Acceleration: 100G Number of impacts: 5	

DIMENSIONS:

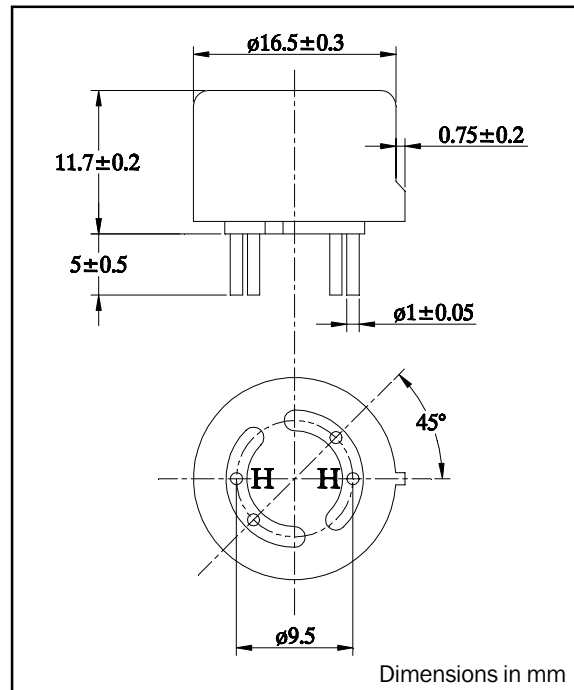

Typical gas sensitivity:

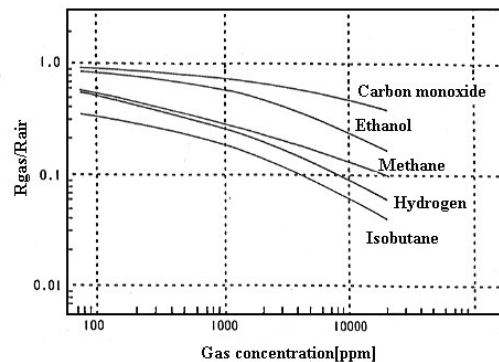

GAS SENSORS : TYPE AF50

METHANE (CH₄) GAS SENSOR

NOTES:

Pin allocation and standard test circuit:

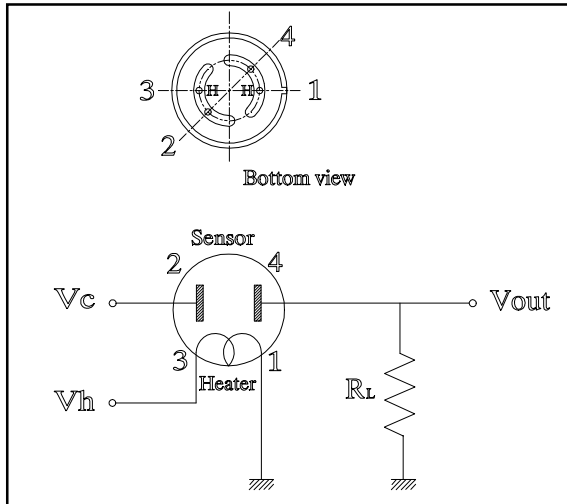

Test conditions:

Atmosphere

Clean air at $25 \pm 2^\circ\text{C}$ and $50 \pm 5\%$ RH without noise gas.

Circuit condition

V_c (circuit voltage) $5 \pm 0.05\text{V}$

V_h (heater voltage) $5 \pm 0.05\text{V}$

Preheat time 48 hours

Test gas

Methane 2000ppm

WARNING:

Do not use if the case or wire netting is damaged, otherwise built-in heater may cause explosions or fires.
Do not disassemble or change any parts.
Use only within specified conditions.