

FIGARO

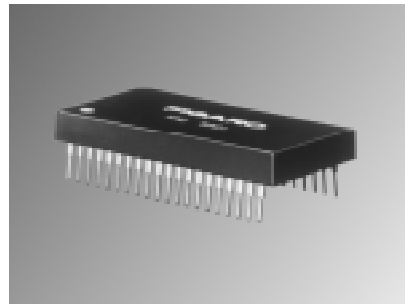

Technical Information for TGS203 Control IC FIC-5401

The FIC-5401 IC unit is a custom hybrid IC which contains the principle circuits for the TGS203 carbon monoxide sensor and also contains a 4-bit microprocessor. This IC unit controls the timing of the heater cycle for TGS203, making its use a convenient method for evaluating the performance of the TGS203 sensor.



	<i>Page</i>
<i>Description</i>	2
<i>Pin Connection of FIC-5401</i>	2-3
<i>Basic Operation</i>	4-5
<i>Alarm Level Adjustment</i>	5-6
<i>Handling of FIC-5401</i>	6
<i>Electrical Characteristics and Specifications</i>	
<i>Dimensions</i>	6
<i>Output Ports</i>	7
<i>Maximum Ratings</i>	7
<i>Standard Operation Conditions</i>	7
<i>Electrical Characteristics</i>	7
<i>Basic Application Circuit</i>	8

See also Technical Brochure "Technical Information for TGS203".

1. Description

The FIC-5401 IC unit is a custom hybrid containing principle circuits for the TGS203 carbon monoxide sensor and a 4-bit microprocessor. Usage of this unit is a convenient way to evaluate the TGS203 sensor. As indicated in Fig. 1, the built-in constant current supply provides the heaters of the TGS203 with two different circuits (IHH and IHL) alternately at a certain interval. The heaters of TGS203 are connected in series and alternately are provided with high heater current (IHH) for 60 seconds followed by a low heater current (IHL) for the succeeding 90 seconds to maintain the sensor at a corresponding high and low temperature. The time interval between IHH and IHL is controlled by the FIC-5401.

An output signal from the TGS203 is received by the detection circuit of the FIC-5401 at the optimized timing. The built-in alarm circuit compares this signal with the preset alarm threshold level and if the signal exceeds this level, an alarm signal can be released. A trouble signal is provided in case any heater disconnection related to the sensor or any faults in the constant current supply circuit have occurred. A built-in temperature compensation circuit decreases the effect of ambient temperature on the sensor. For controlling these functions, the FIC-5401 contains a 4-bit microprocessor which is timed by a built-in high precision timer. The FIC-5401 is designed to be driven by a single 5V power supply, allowing battery-operated application.

Two alarm levels can be set: the main alarm (Alarm A) provides larger current than the subalarm (Alarm B) so that the output from Alarm A can directly activate an LED or a piezoelectric buzzer. Please refer to the section titled "Application Circuit" for further details.

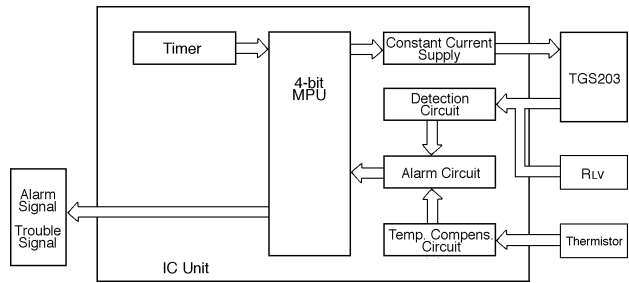

Fig. 1 - Block diagram of IC Unit

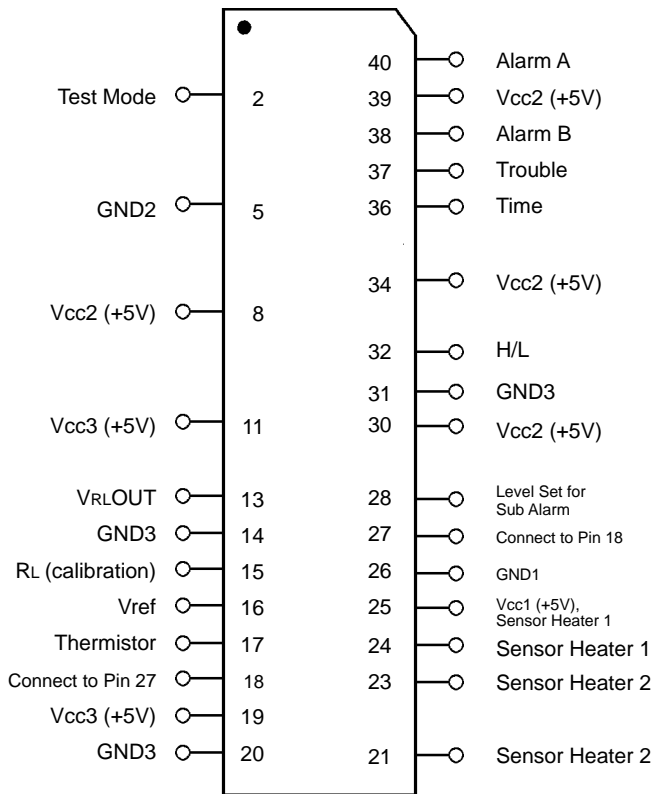

Fig. 2 - Pin connection of IC Unit (top view)

2. Pin Connections of FIC-5401

- 1) All VCC and GND terminals must be properly connected.
- 2) VCC and GND terminals are to be divided into the 3 groupings shown in Table 1. Printed circuit boards must be carefully designed to consider the features in the internal circuit.
- 3) Electric noise may be decreased by connecting a capacitor (1μF) between Pins GND2 and 18 or GND2 and 27. Connect the GND2 terminal to the minus polarity of the capacitor.

Vcc1 (Pin 25)	GND1 (Pin 26)	For heater circuits. Max. current ≈ 400mA
Vcc2 (Pins 8,30,34,39)	GND2 (Pin 5)	For digital/analog circuits. Max. current = 120mA
Vcc3 (Pins 11,19)	GND3 (Pins 14,20,31)	For analog circuits only. Electric noise must be avoided.

Table 1 - Vcc and GND terminal groupings

TECHNICAL INFORMATION FOR FIC-5401

Pin Name	Pin #	I/O	Function
<i>The following pins must be connected as indicated:</i>			
VCC: VCC1 VCC2 VCC3	25 8,30,34,39 11,19		+5V (These pins should be separated into three groups. See "Pin Connection of FIC-5401")
GND: GND1 GND2 GND3	26 5 14,20,31		GND (0V) (These pins should be separated into three groups. See "Pin Connection of FIC-5401")
Sensor - Heater 1	24,25		Connect one heater of sensor (sensor pin # 1&2 or 3&4)
Sensor - Heater 2	21,23		Connect to heater opposite that for Heater 1 (sensor pin #3&4 or 1&2)
RL for Calibration	15		Connect the variable load resistor RLV between Pin 15 and GND3
Test Mode	2		Connect Pin 2 to SW1 (see Fig. 3). Pin for alarm level adjustment
Thermistor	17		Connect thermistor between Pin 17 and VCC1 (+5V)
--	18,27		Connect Pin 18 to Pin 27
--	13,21		Connect Pin 13 to Pin 21
<i>The following pins are used according to user's application:</i>			
Level Set for Subalarm	28		Terminal to set subalarm Connect Pin 28 to GND3 to set subalarm level at 1/3 of main alarm conc.
Vref	16	Output	Monitor threshold of main alarm level
Alarm A	40	Output	Main alarm level output (held until next timed detection signal is released) Connect LED or piezoelectric buzzer which can be directly activated by built-in power transistor
Alarm B	38	Output	Subalarm level output TTL compatible (active Low)
Trouble	37	Output	Trouble signal output (held until next timed detection signal is released) Trouble signal released when any heater disconnection related to sensor or faults in constant current power supply circuit for heaters have occurred TTL compatible (active Low)
VRLOUT	13	Output	Monitor VRL output -- output meaningful ONLY at moment of Gas Detection Period
H/L	32	Output	Monitors periods of IHH and IHL TTL compatible
Time	36	Output	Synchronizes pulse output during IHL period TTL compatible
<i>The following pins should <u>not</u> be connected:</i>			
NC	1,3,4,6,7, 9,10,12,22, 29,33,35		No connection

Table 2 - Pin Functions

3. Basic Operation

The basic operation circuit of the TGS203 is shown in Fig. 3. Load resistor (RL) consists of a variable resistor (RLV*) and an internal fixed resistor (1kΩ), so $R_L = R_{LV} + 1k\Omega$. Connect Pin 2 to GND2 through SW1, which should normally be kept off. Then connect the thermistor (Th) between Pin 17 and VCC1 (+5V) and supply the specified pins with a circuit voltage (VCC) of +5V. Upon doing so, the TGS203 will start to operate according to the preprogrammed sequence.

The FIC-5401 contains a constant current supply circuit. Fig. 4 shows the equivalent circuit which indicates how the sensor, constant current supply, and RL are connected. The two heaters are connected in series during the period when the sensing element is heated (Element Heated Period). During this period, high heater current (IHH) flows through the heaters for 60 seconds, subsequently followed by the low heater current (IHL) for 90 seconds.

Both heaters are periodically switched off at the moment when the sensor is optimally set to detect gas (Gas Detection Period) and simultaneously, the output signal (VRL) is fed into the alarm circuit. When the VRL exceeds the preset alarm threshold level (Vref), a high level alarm signal is released from Pin 40 "Alarm A" and this level is maintained until VRL drops below the Vref. Vref can be directly monitored through the output from Pin 16.

The timing chart in Fig. 5 shows the full details of TGS203 operations as described above. The VRL at the 500ms Gas Detection Period is compared with Vref, and if this VRL is higher than Vref, an alarm signal is released from Alarm A (Pin 40).

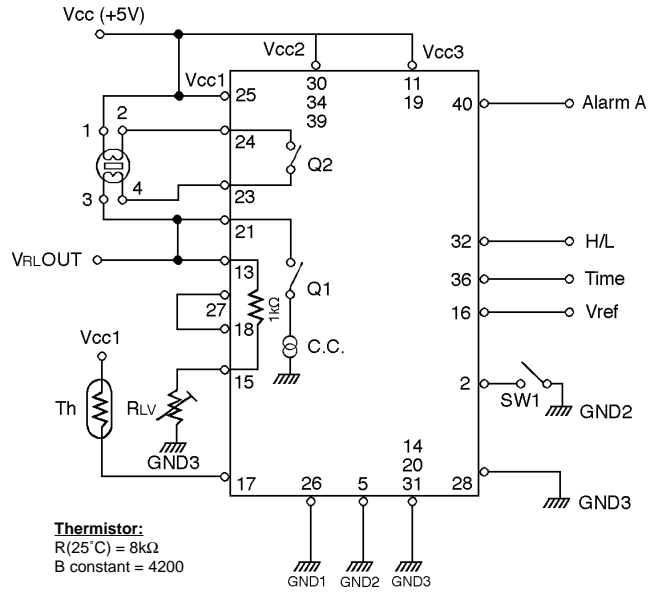

Fig. 3 - Basic application circuit

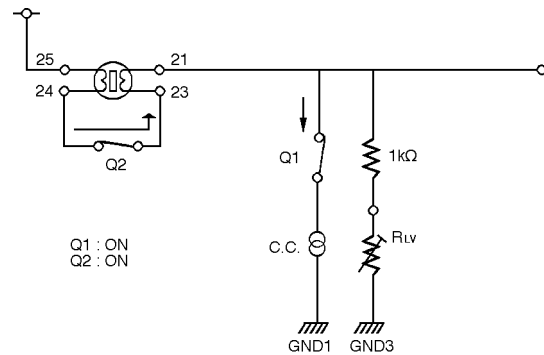

Fig. 4a - Element heated period

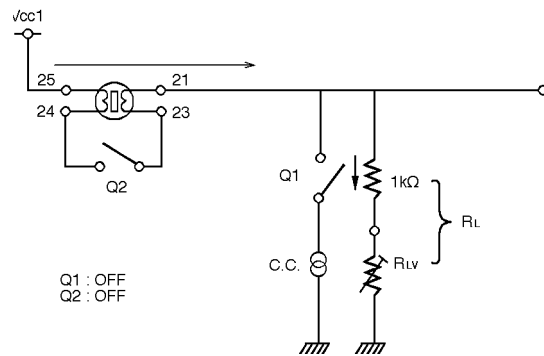

Fig. 4b - Gas detection point

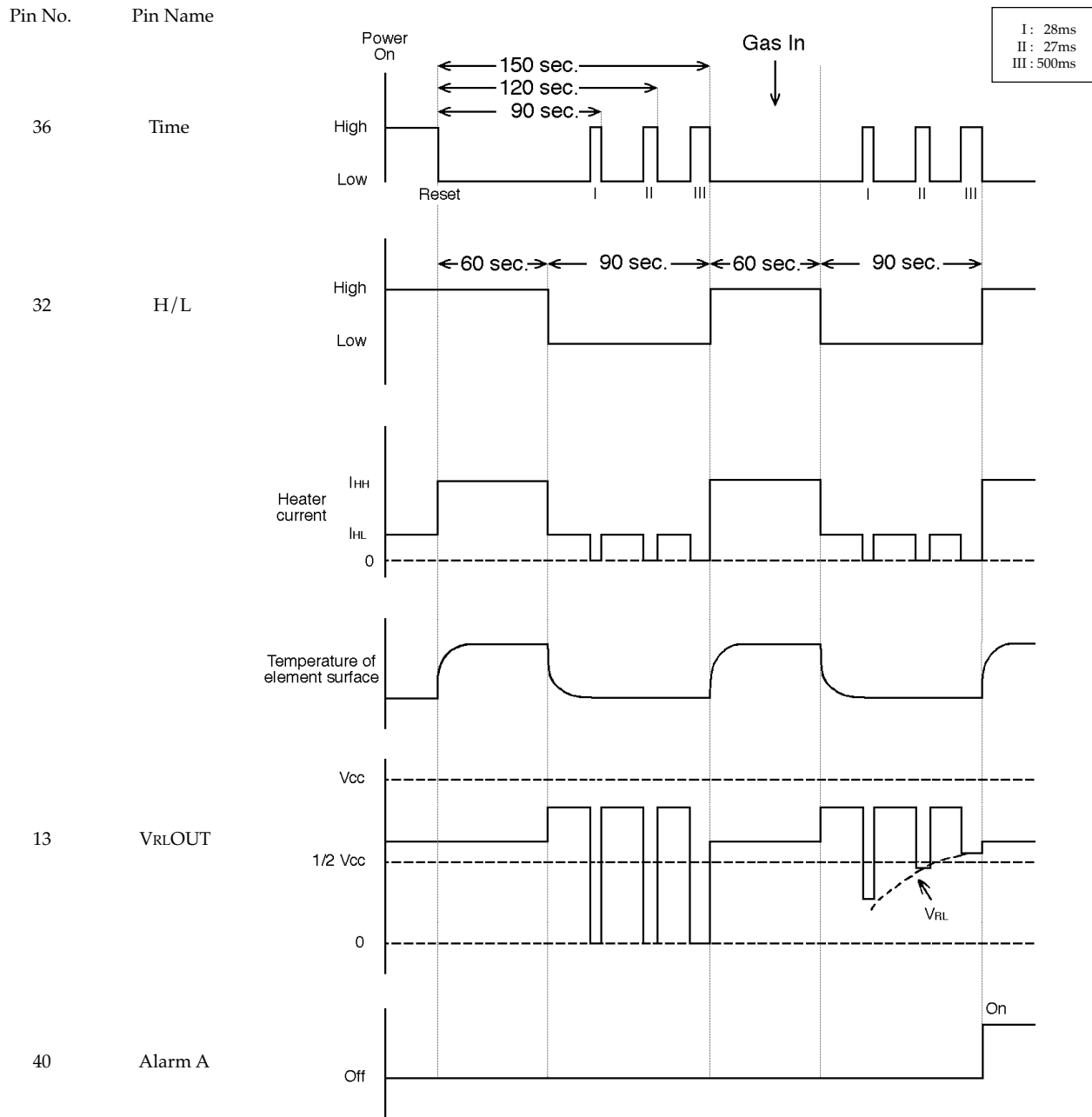

Fig. 5 - Timing chart

4. Alarm Level Adjustment

- 1) Prepare the circuit shown in Fig. 3. Turn off SW1 and set RLV at half the maximum value of RLV.
- 2) Place the circuit in a chamber filled with the target concentration of CO. Standard test conditions of 20°C and 65% RH are recommended. Lead the outputs from VRL_{OUT} (Pin 13) and V_{ref} (Pin 16) outside the

chamber.

- 3) Monitor the outputs from VRL_{OUT} and V_{ref}. After more than two heating cycles, read VRL at the Gas Detection Period.
- 4) Remove the circuit from the chamber and switch it off, disconnect the sensor, and connect a variable resistor between Pins 21 and 25 of the FIC-

5401. The maximum resistance value of this variable resistor should be $20k\Omega$ if the CO concentration to be detected is 100ppm or higher, and $50k\Omega$ if the concentration is to be less than 100ppm. This resistor is used only for alarm level adjustment.

5) After turning SW1 on, turn on the circuit, which is then in a fixed position as shown in Fig. 4.b—both Q1 and Q2 are off.

6) Set the VRL0UT to match the VRL obtained in the above procedure by adjusting the variable resistor.

Note: The resistance of the variable resistor is adjusted to the same value as that of the sensing element as observed in step 3 above.

7) Adjust RLV so that the VRL0UT matches the Vref obtained in step 3 above.

8) Replace the variable resistor with the disconnected sensor and turn off SW1.

Connecting Pin 28 to GND3 allows subalarm (Alarm B) level to be set at approx. 1/3 of main alarm's concentration level. The subalarm level can be optionally set at a higher concentration than the main alarm.

5. Handling of the FIC-5401

1) The FIC-5401 includes a one-chip microcomputer consisting mainly of CMOS and NMOS transistors, and some of their terminals are connected directly to the IC's pins. All possible measures are required to protect the FIC-5401 from static charge throughout the process of transportation, storage, assembly, inspection, etc.

2) The FIC-5401 should be the last to be inserted into the printed circuit board or system so as to avoid overhandling.

3) Make sure that the power supply is off and the unit is grounded before connecting to any external signal sources.

4) A proper surge protector should be placed at the power intake for systems which are to be powered by AC power, car batteries, etc. which are likely to emit highly energized surges.

5) Handle with care for protecting from mechanical shock.

6. Electrical Characteristics and Specifications

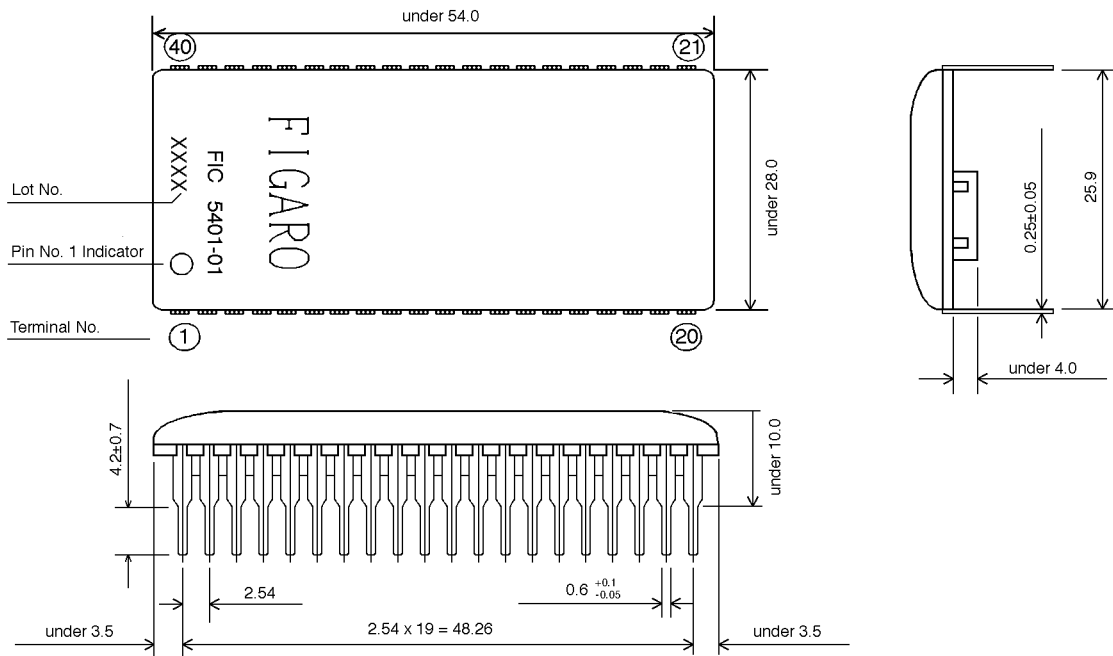

Fig. 6 - FIC-5401 Dimensions (u/m=mm)

Output Ports

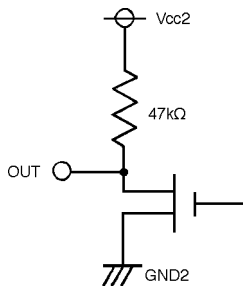

Fig. 7a - Pins 37, 38

This output port is connected to Vcc2 through a built-in pull-up resistor of 47kΩ. The open-drain low level output current is 12mA max.

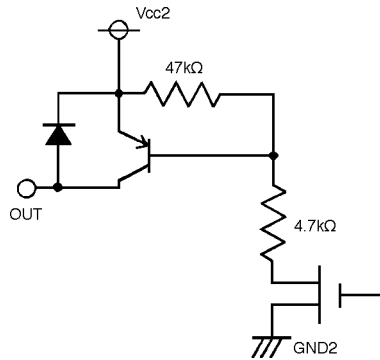

Fig. 7b - Pin 40

Open collector output. IOH is 100mA max.

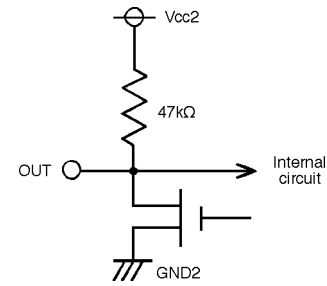

Fig. 7c - Pins 32, 36

This output port is connected to Vcc2 through a built-in resistor of 47kΩ. This output port is connected to another internal circuit and the printed circuit board should be designed in such a way that electrical noise should be avoided.

Maximum Ratings

Item	Symbol	Rated Value
Power supply voltage	Vcc	-0.3~+7.0V
Input voltage	Vi	-0.3~Vcc
Output voltage	Vo	-0.3~Vcc
Power dissipation	Pd	1.5W (when sensor is connected)
Operating temperature	Topr	-10~+50°C
Storage temperature	Tstg	-25~+85°C

Standard Operating Conditions

Item	Symbol	Pin No.	Rated Value
Power supply voltage	Vcc	8,11,19,25,30,34,37	5.0V +5%
GND	GND	5,14,20,26,31	0V
LOW level output current	IOL(sink)	37,38	11.8mA max.
HIGH level output current	IOH	40	100mA max.
Allowable heater resistance (incl. wiring resistance)	RH	24/25, 21/23	3.3Ω max.

Electrical Characteristics

Item	Symbol	Pin No.	Condition	Rated Value
Low heater current	IHL			0.133 ± 3% A
High heater current	IHH			0.369 ± 3% A
HIGH level output voltage	VOH1	32,36,37,38		Vcc-0.5V min.
HIGH level output voltage	VOH2	40	I(sink)=0mA	Vcc-0.6V typical
LOW level output voltage	VOL1	37,38	IOL(sink)=11.9mA	2.0V max.
LOW level output voltage	VOL2	32,36	IOL(sink)=1.5mA	0.4V max.

7. Application Circuit

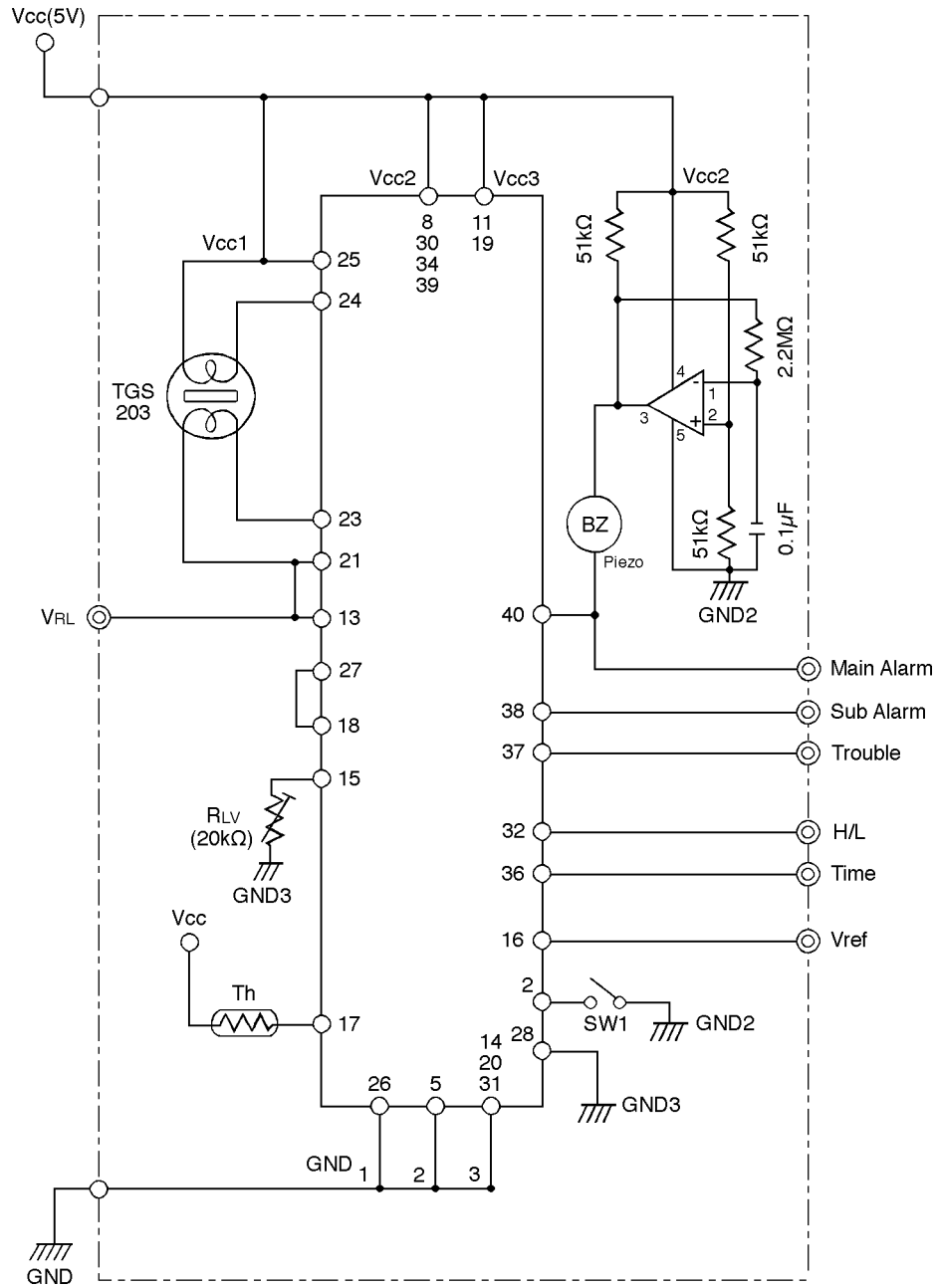

Fig. 8 - Example of application circuit

The connection of Pin 28 to GND3 allows the subalarm level (Alarm B) to be set at 1/3 of the main alarm level (Alarm A). Using the output of Pin 38 allows the application to have an early warning alarm which is released at a lower concentration than that of the main alarm.

Since the heater is supplied with a constant current, the sensor can be positioned away from the IC unit by means of an extension cable. Allowable heater resistance between Pins 24 and 25 or Pins 21 and 23 (i.e. combined resistance of the heater and extension cable) must not exceed 3.3Ω.